

TR2 POWER RACK ASSEMBLY GUIDE

VERSION: TR2-PR-101

PART #: 5929801-C

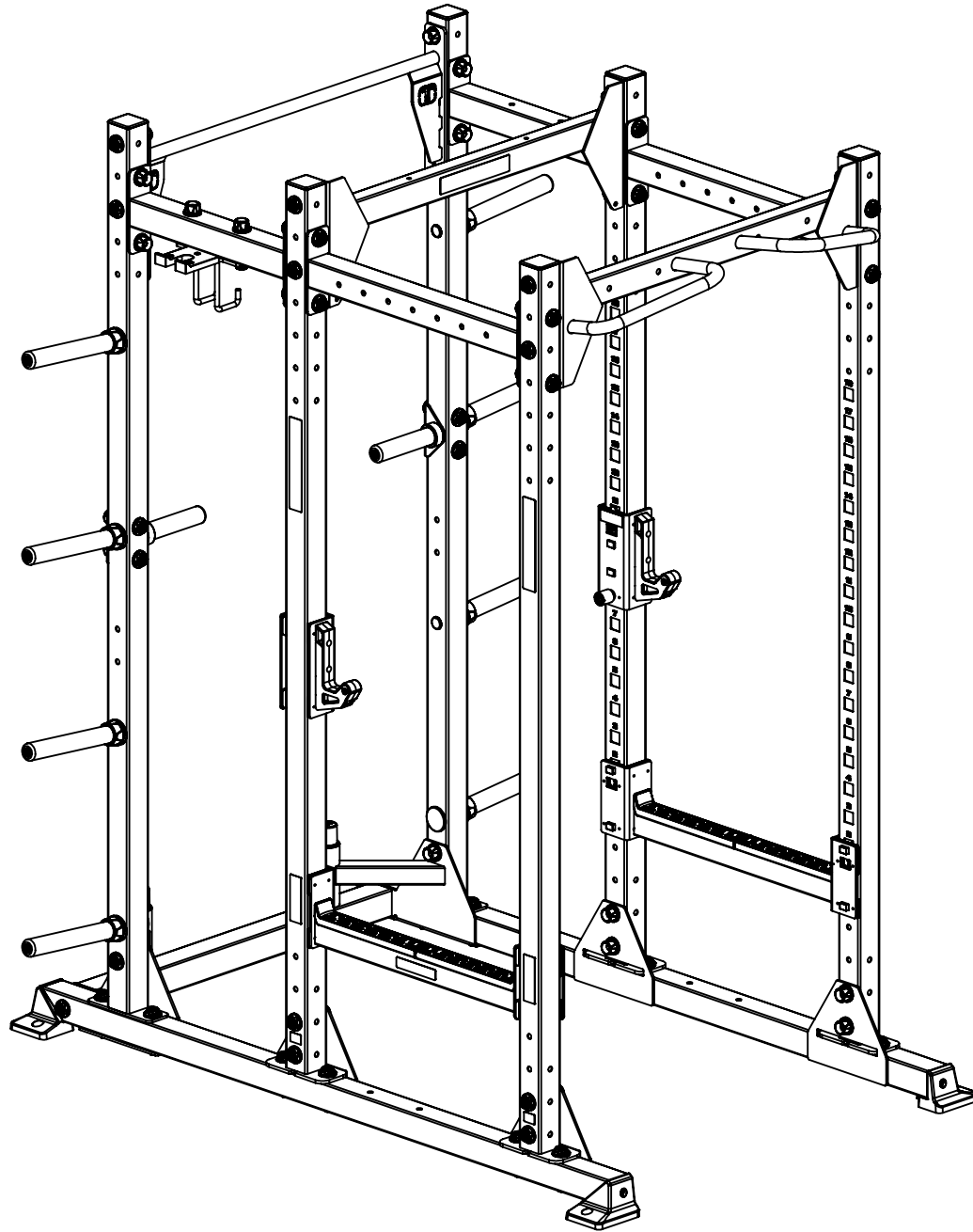

WARNING !

Important safety instructions for using Equipment

There is a risk assumed by the individuals who use this type of equipment. To minimize risk, you must follow these precautions:

1. **READ ALL INSTRUCTIONS AND WARNING LABELS COMPLETELY PRIOR TO ANY USE OR ASSEMBLY.** Failure to read and follow the safety instructions and warnings within the Assembly and Maintenance Guide may result in possible serious injury or death. Use this product only for the intended uses described in the Assembly and Maintenance Guide and exercise booklet. **DO NOT** modify equipment in any way. **Any use other than as intended or modification of product will void any and all product warranties.**
2. Consult your physician before starting any exercise program. Warm up properly before engaging in resistance training. Stop exercising and consult a physician immediately if you experience dizziness, nausea, faintness, chest pain, shortness of breath or any other abnormal symptoms during use of this equipment.
3. Certain exercise equipment and/or equipment may not be suitable or appropriate for pregnant women, people with heart conditions, balance impairment or other pre-existing health problems. Persons with disabilities should consult a physician and obtain medical approval prior to using this product and should only use this product under close supervision. **Failure to comply with these instructions will void any and all product warranties.**
4. Carefully inspect equipment before each use. Replace all parts at the first sign of wear or damage. Tighten all loose connections. Do not disassemble, remove any parts or components or otherwise attempt to repair this product. **DO NOT** use product if product appears damaged. **DO NOT** attempt to fix a broken or jammed machine, obtain assistance by contacting www.service@torquefitness.com. **Failure to comply with these instructions will void any and all product warranties.**
5. Keep body and clothing clear of all moving parts. Do not put any foreign on or near this product when in use. Wear comfortable clothing which does not impair freedom of movement. Do not wear clothing which is too loose and could get caught in moving parts.
6. Children and pets must not be allowed near this machine. Supervise teenagers. This product is not a toy.
7. If unsure of proper use of this product, contact Torque Fitness Customer service at: 763-754-7533 or www.service@torquefitness.com

Important Safety Instructions for Assembling Equipment

1. **Assistance is required. Torque Fitness recommends using more than one person to assemble this equipment.**
2. This product must be assembled on a flat, level surface to assure its proper function. Locate the unit a few inches from walls or furniture to allow easy access during assembly and use.
3. Read each numbered step in Assembly and Maintenance Guide and follow the steps in sequence. Skipping ahead may result in damage to the equipment and may require components to be disassembled.
4. Wear proper attire during the assembly process. Do not wear clothing which is too loose or open toed shoes.

Obtaining Service

Do not attempt to service the product yourself except for maintenance tasks described in this manual.

Refer to the Adjustments and Maintenance section at the back of this manual for information on product operation and service.

For further information, visit our website at www.torquefitness.com or contact us at www.service@torquefitness.com

If you call or email customer service, have the model number and serial number(s) available. The location of the model and serial numbers are indicated in the back of this manual. For future reference, write the model and serial number(s) in the space below.

Model Number: _____

Serial Number(s): _____

GENERAL NOTES

CAUTION: More than one person is required to assemble this unit. Do not attempt to assemble by yourself.

Unpacking the Equipment

This product may be packaged and shipped in multiple boxes. Parts from all of the boxes are required for various steps during the assembly process.

Carefully open each box and arrange all the parts near the area where assembly is to take place.

CAUTION: Use extreme care when cutting plastic tie wraps and package banding. A wire cutter works best for protecting yourself and the parts.

CAUTION: Some of the internal boxes may contain upholstery. Do not use a utility knife to open any boxes or the pads may be damaged.

The hardware is packed in bags. Carefully open each bag and sort them per parts list on the next page.

Before starting assembly, identify each part and hardware item as listed in the parts list on the next page. If any items are missing, contact Torque Fitness Customer service at: 763-754-7533 or www.service@torquefitness.com

Note: Some items listed in the parts list may already be pre-installed on the product.

Tools Required

- Rubber mallet or hammer
- 3/4" Box wrench or adjustable wrench
- Or 3/4" Socket and 3/8" ratchet
- 3/8" Allen wrench
- 3/16" Allen wrench
- Wire snips (to cut plastic tie wraps)
- Scissors or utility knife (to cut hardware bags)
- Step stool or ladder
- Tape measure

Optional Equipment

Optional equipment may be available for this product.

Follow the instructions included with the optional equipment to assemble it to the base product.

Assembly Tips

- In a continual effort to improve our products, specifications are subject to change.
- A 6" scale is provided at the bottom of this page. To correctly measure the bolts, measure from underneath the bolt head to the end of the bolt as illustrated below.
- Read all notes on each page before beginning that step.
- Some of the items shown in the assembly steps may already be pre-assembled.

Assembly Tips Continued

- **Note:** Some items have been hidden for assembly clarity.
- **Note:** Some pre-assembled parts may need to be temporarily removed in order to complete the step. Follow the instructions or damage to the product could occur.
- Some parts may have extra holes that will not be used. Use only the holes depicted in the instructions.
- Certain parts make reference to the right and left side of the machine. In order to determine the left and right side, stand in front of the machine.
- Provide ample space around the product for ease of assembly.
- **DO NOT** fully tighten any connections until instructed to do so. This will help insure that the alignment of all of the parts will be correct.
- Insert all bolts in the direction indicated in the instructions. Failure to do so may result in clearance issues and will degrade the aesthetics of the product.
- Carefully follow instructions for all pivot points. In general, primary rotating parts have connections that should be securely tightened, while secondary connections need to be loosen 1/4 turn.

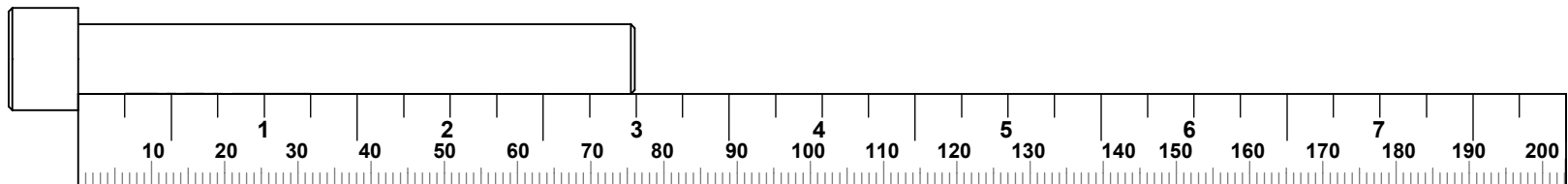

ITEM NO.	PART NUMBER	DESCRIPTION	QTY.
1	5884301	WLDMT, PR LEFT BASE	1
2	5872801	CASTING, BASE FOOT 2	2
3	5872701	CASTING, BASE FOOT 1	2
4	5884501	WLDMT, PR RIGHT BASE	1
5	2006803	SHCS, 1/2-13 X 1, CZ PATCH	4
6	5873101	WLDMT, REAR BASE CONNECTOR	1
7	5631801	WASHER COVER, NYLON BOLT	50
8	2006815	BOLT, 1/2-13 X 4" (102mm) SOCKET HEAD W/NP	2
9	58737PA	PTD ASSY, WEIGHT HORN UPRIGHT	2
10	2005816	BOLT, 1/2-13 X 4-1/4" (108mm) SOCKET HEAD	14
11	2021001	NUT, 1/2-13 HEX FLG LK ST ZN	12
12	2005815	BOLT, 1/2-13 X 4" (102mm) SOCKET HEAD	34
13	5631901	WASHER COVER, NYLON NUT	36
14	2001401	NUT, 1/2-13 LK ST ZN	36
15	58274PA	PTD ASSY, 8' UPRIGHT	4
16	5874301	WLDMT, UPRIGHT CONNECTOR	2
17	5884601	WLDMT, PR FRONT UPRIGHT CONNECTOR	2
18	5442801	WLDMT, 4' SINGLE CROSS	1
19	58754PA	PTD ASSY, REAR UPPER CROSS	1
20	58749PA	PTD ASSY, MULTI-GRIP PULL-UP	1
21	58745PA	PTD ASSY, OLYMPIC BAR HOLDER	1
22	5876401	CAP, END-COLLAR HOLDER	2
23	2045201	PPMS, 1/4-20 X 1/4, BO, SS	4
24	59167PA	PTD ASSY, LEFT BAR SUPPORT	1
25	59166PA	PTD ASSY, RIGHT BAR SUPPORT	1
26	58848PA	PTD ASSY, PR BAR CATCH	2
27	WSNK5-55-101	WEIGHT STORAGE NUMBERING KIT 5-55	1

NOTE:

To assemble POWER RACK follow the steps on pages 6 through 21 and 45 through 48.

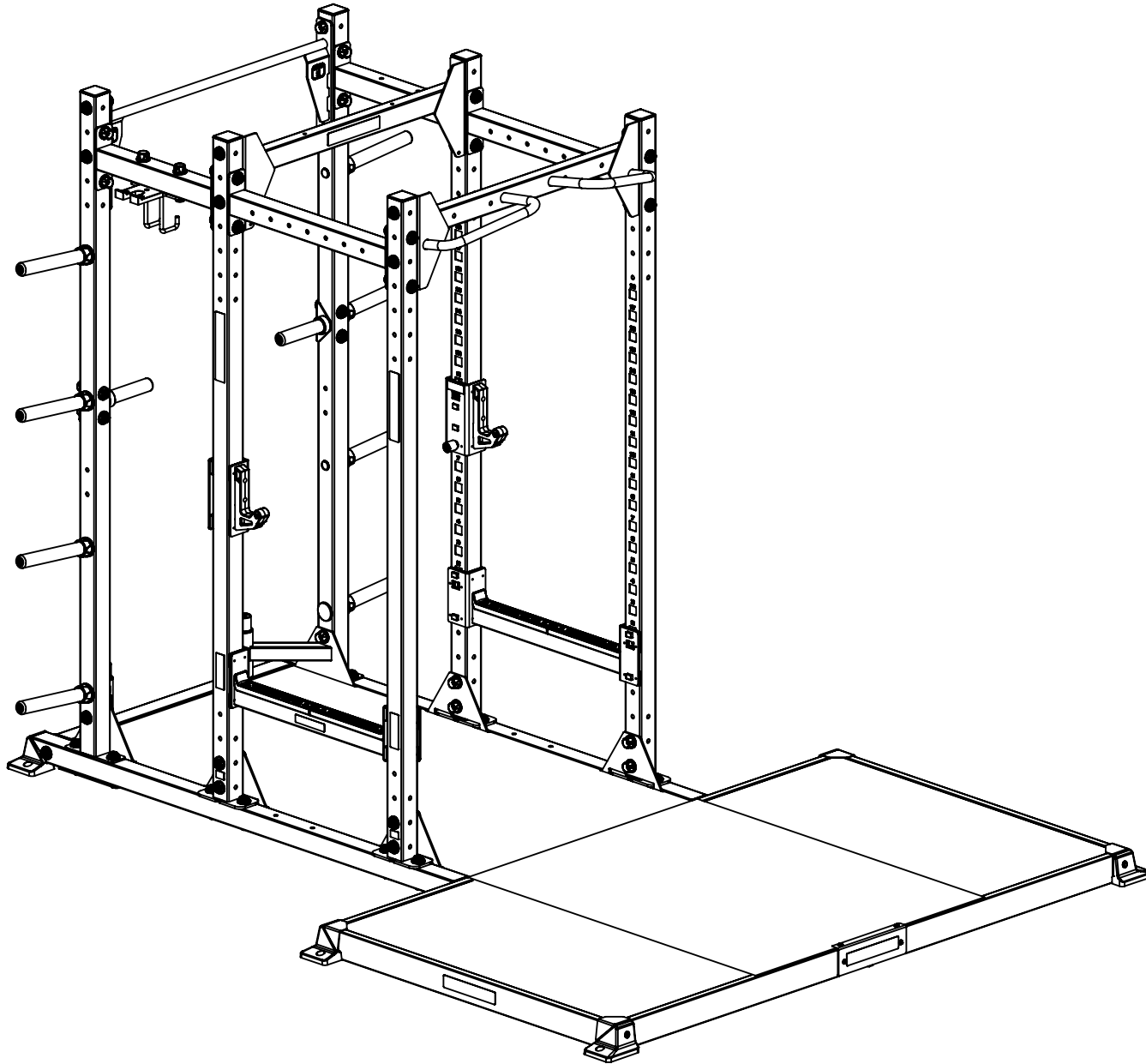

NOTE:

If assembling Platform at the same time as Power Rack, please refer to the Platform Instructions first, then proceed with these instructions skipping steps 1 and 2 and starting with step 3.

STEP 1

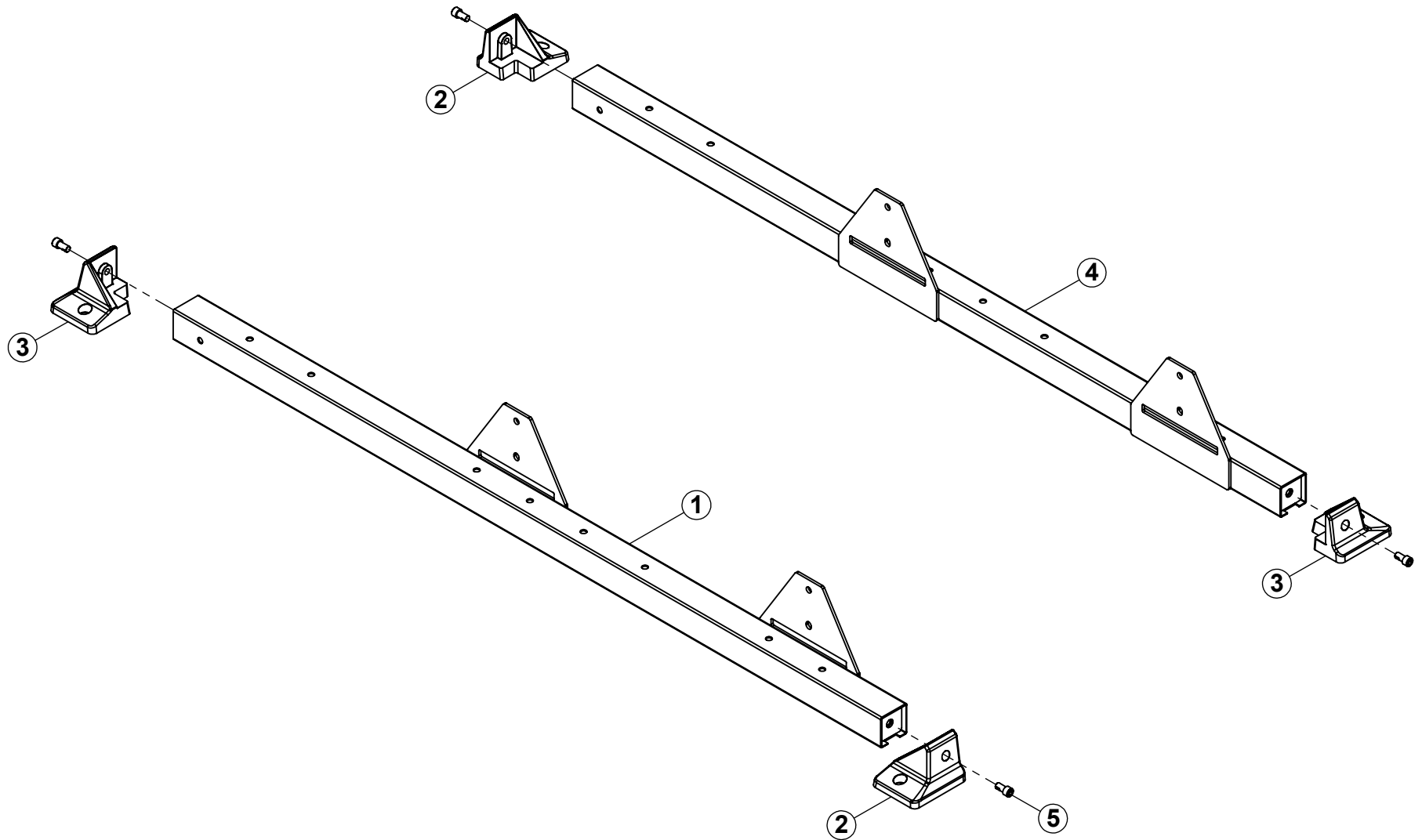

NOTE:

SECURELY tighten all bolt connections in this step.

STEP 2

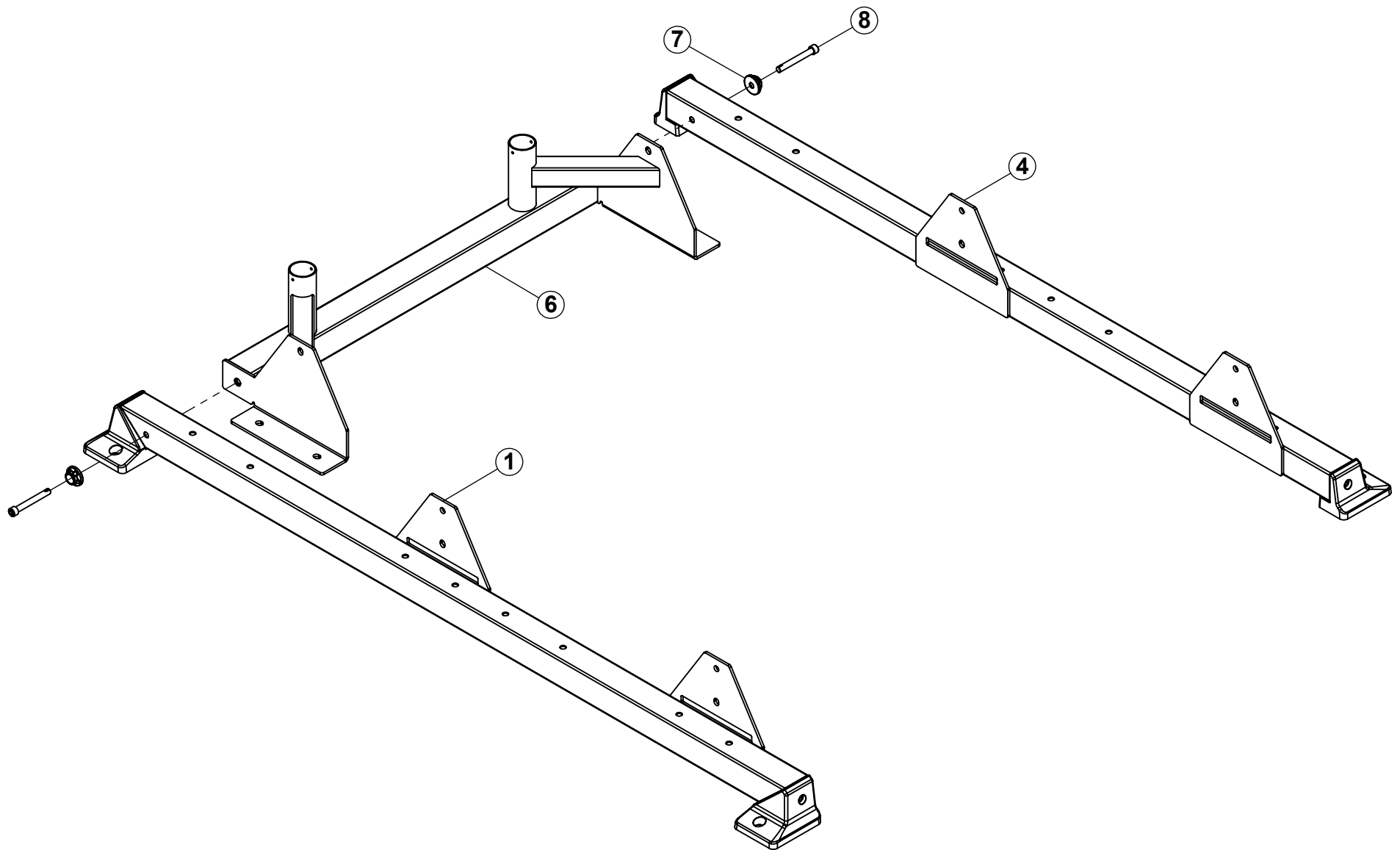

NOTE:

LOOSELY assemble bolt connections in this step.

STEP 3

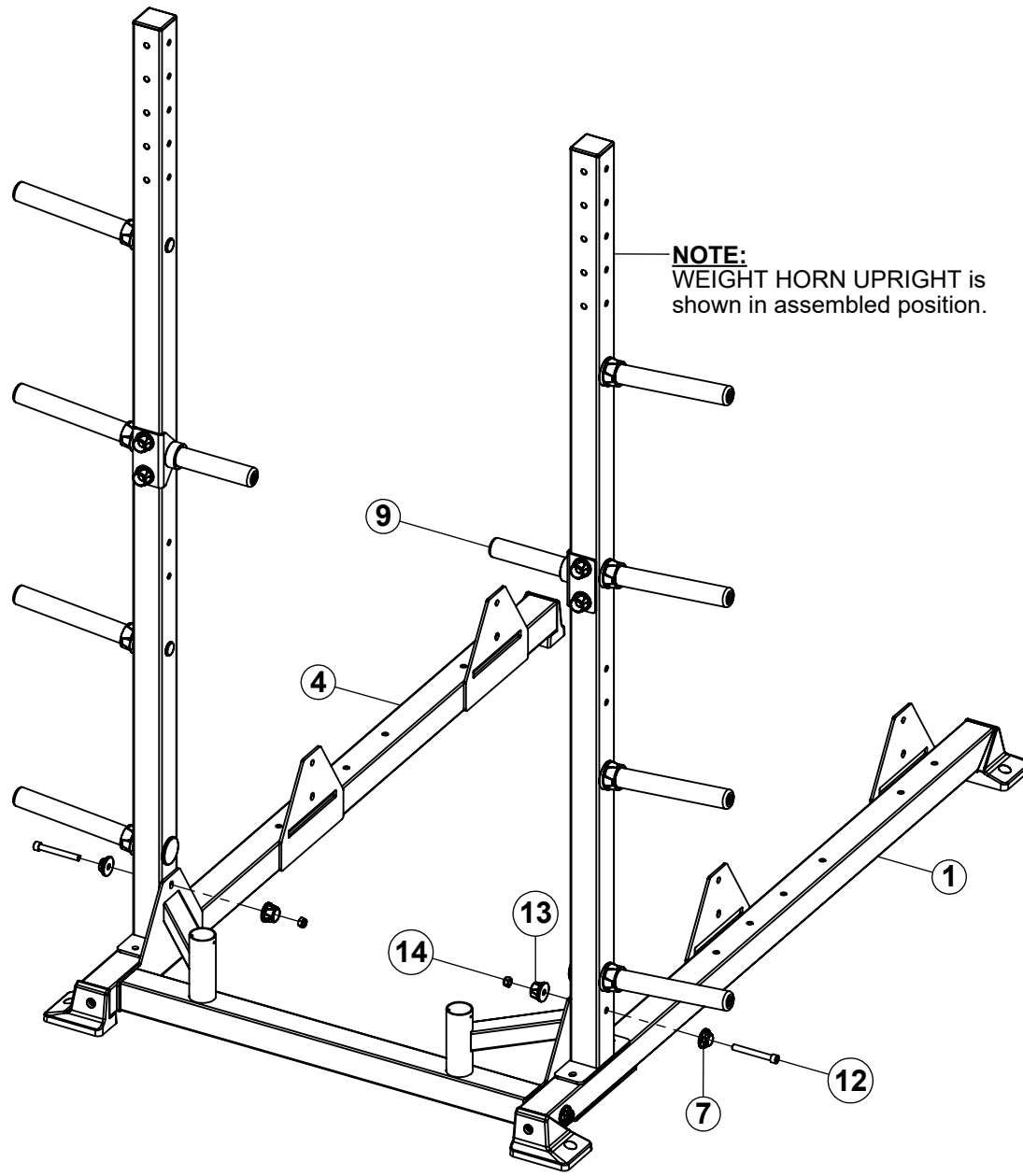

NOTE:

LOOSELY assemble bolt connections in this step.

STEP 4

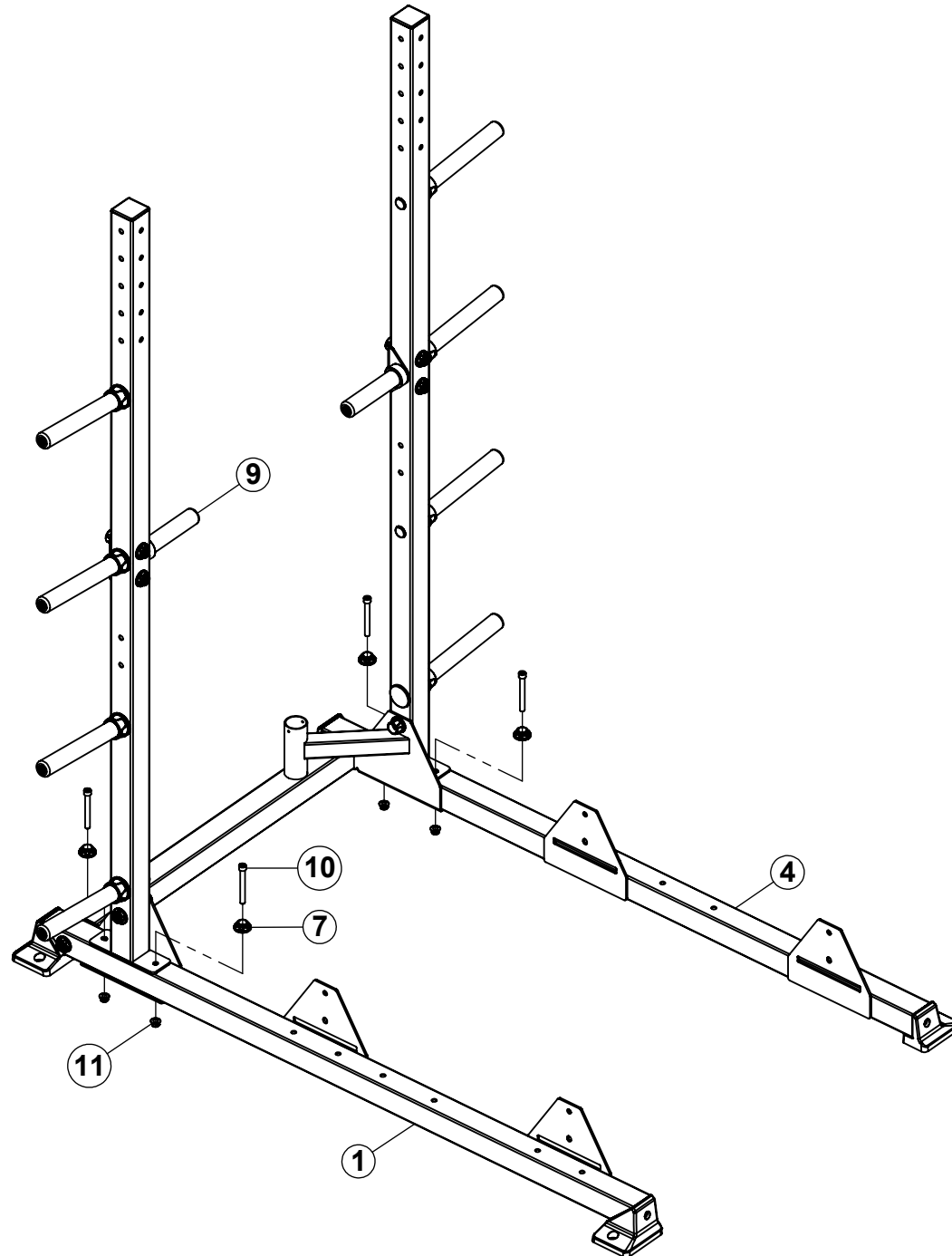

NOTE:

LOOSELY assemble bolt connections in this step.

STEP 5

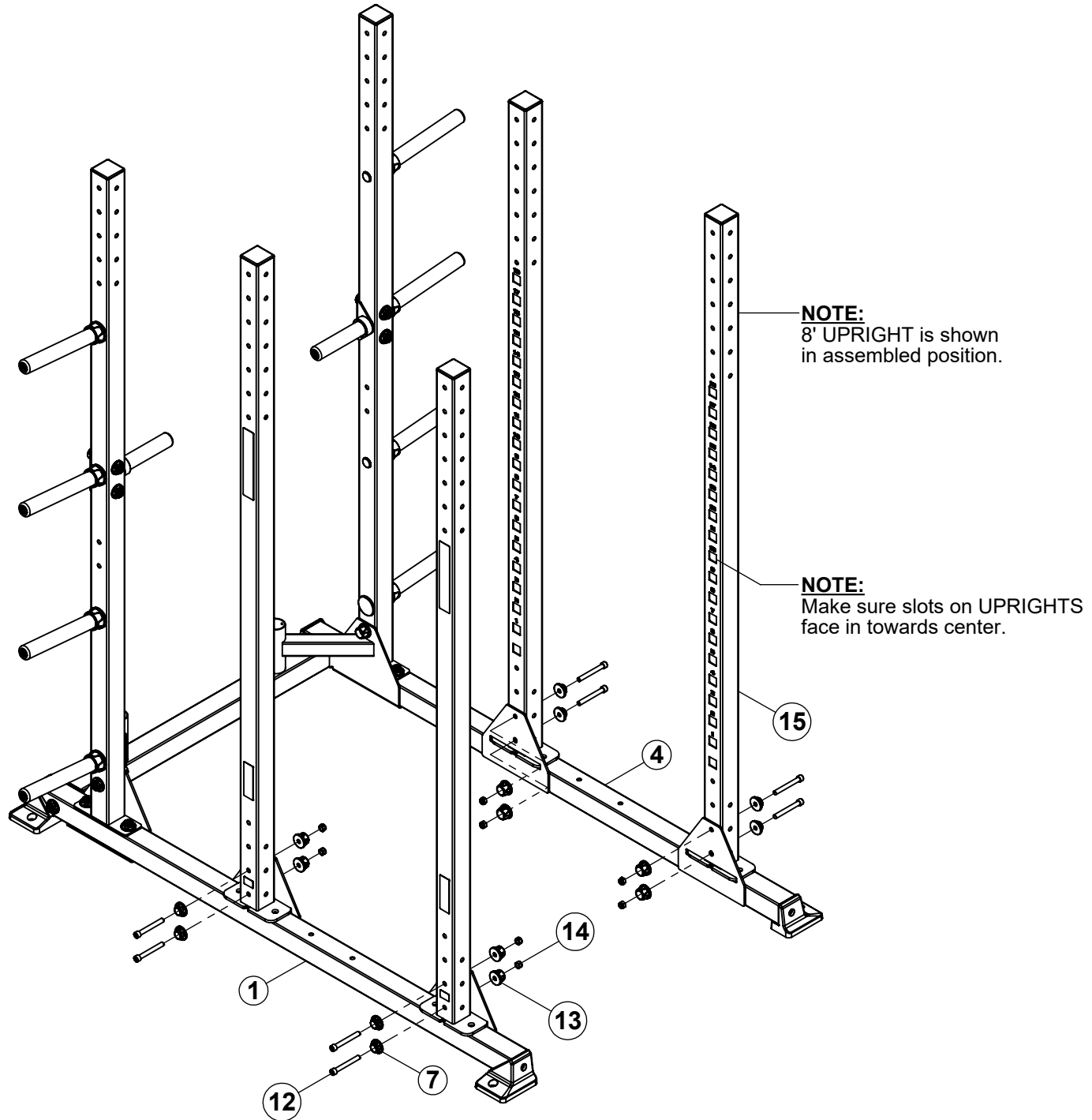

NOTE:

LOOSELY assemble bolt connections in this step.

STEP 6

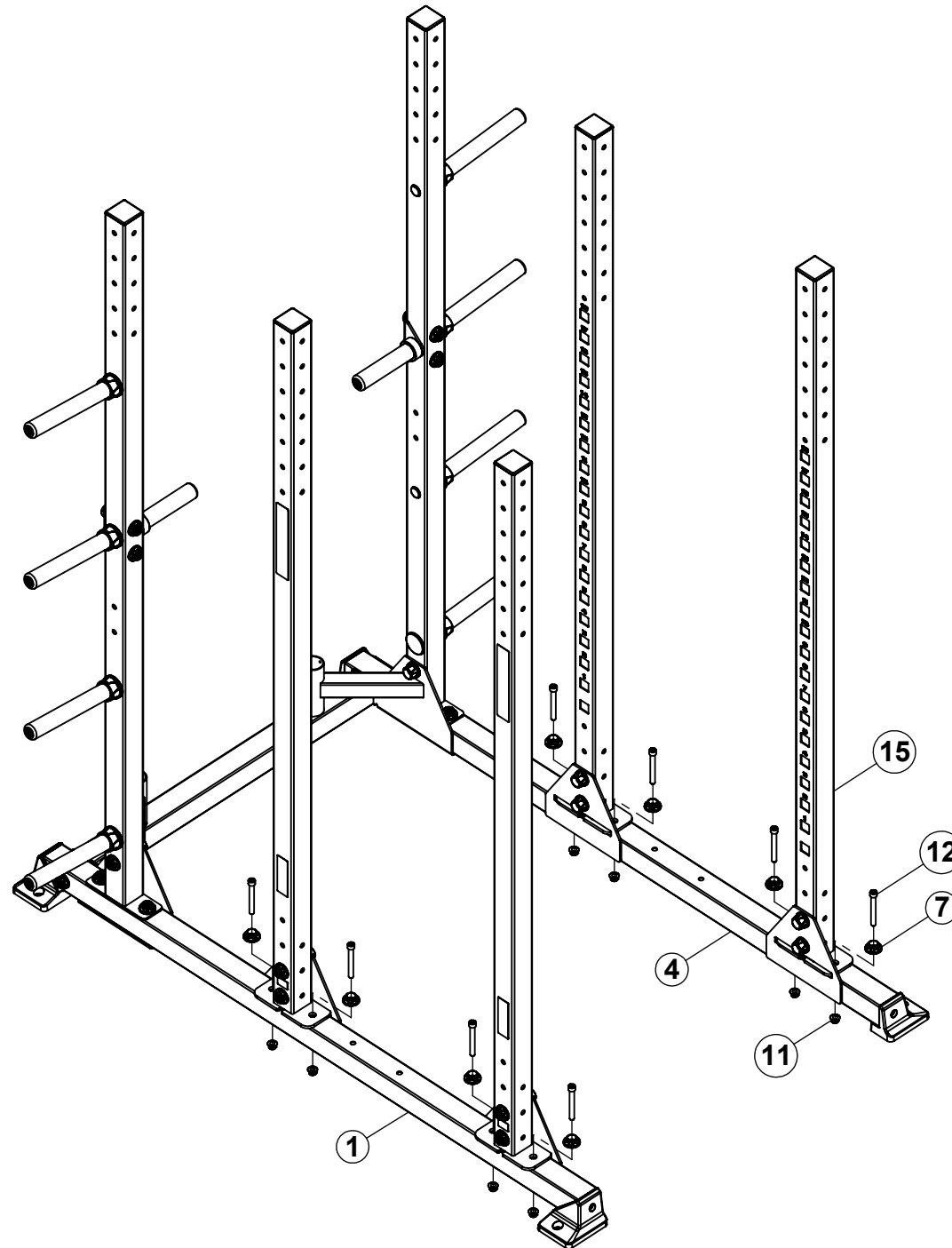

NOTE:

LOOSELY assemble bolt connections in this step.

STEP 7

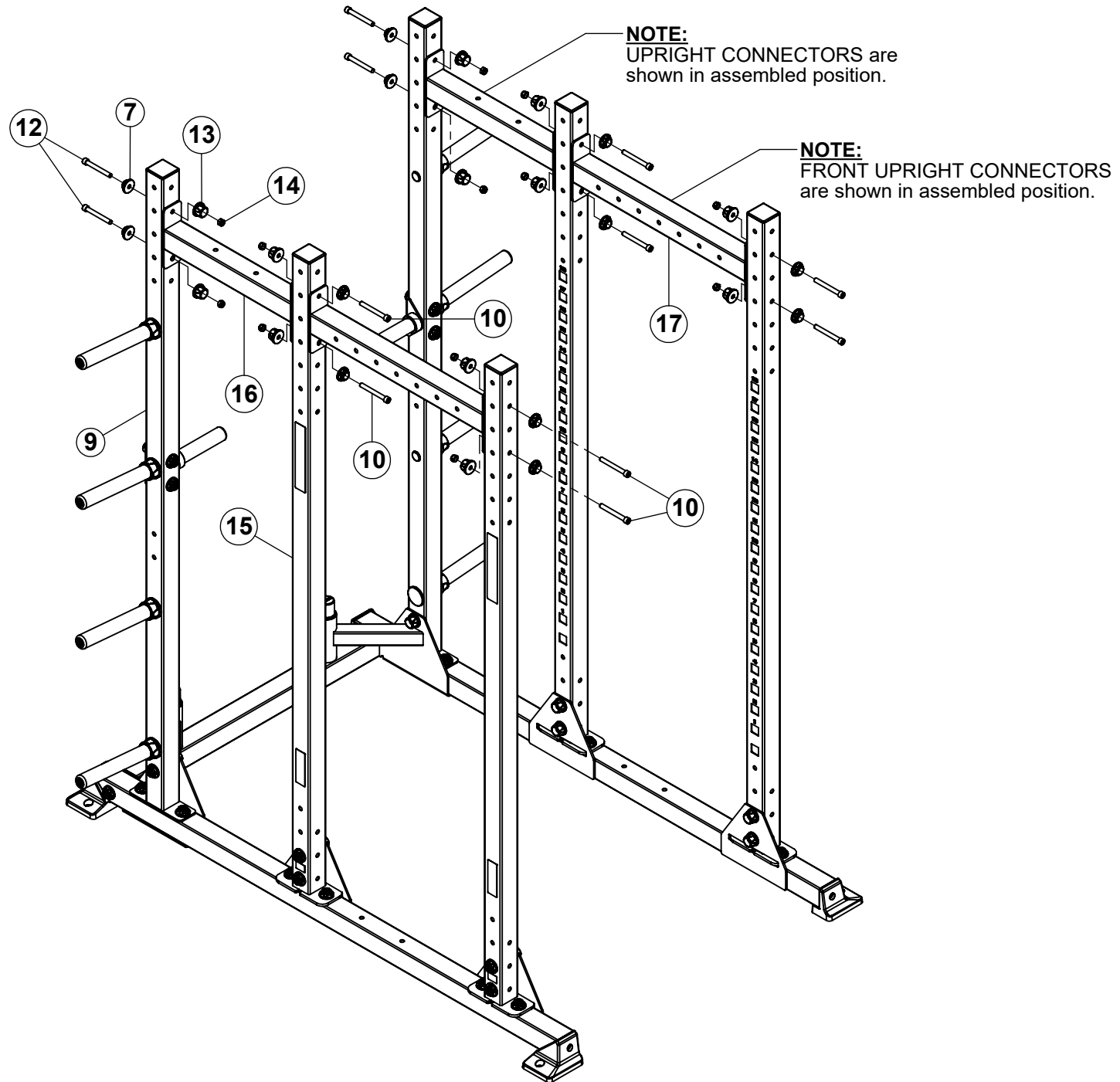

NOTE:

LOOSELY assemble bolt connections in this step.

STEP 8

NOTE:
4' SINGLE CROSS is
shown in assembled position.

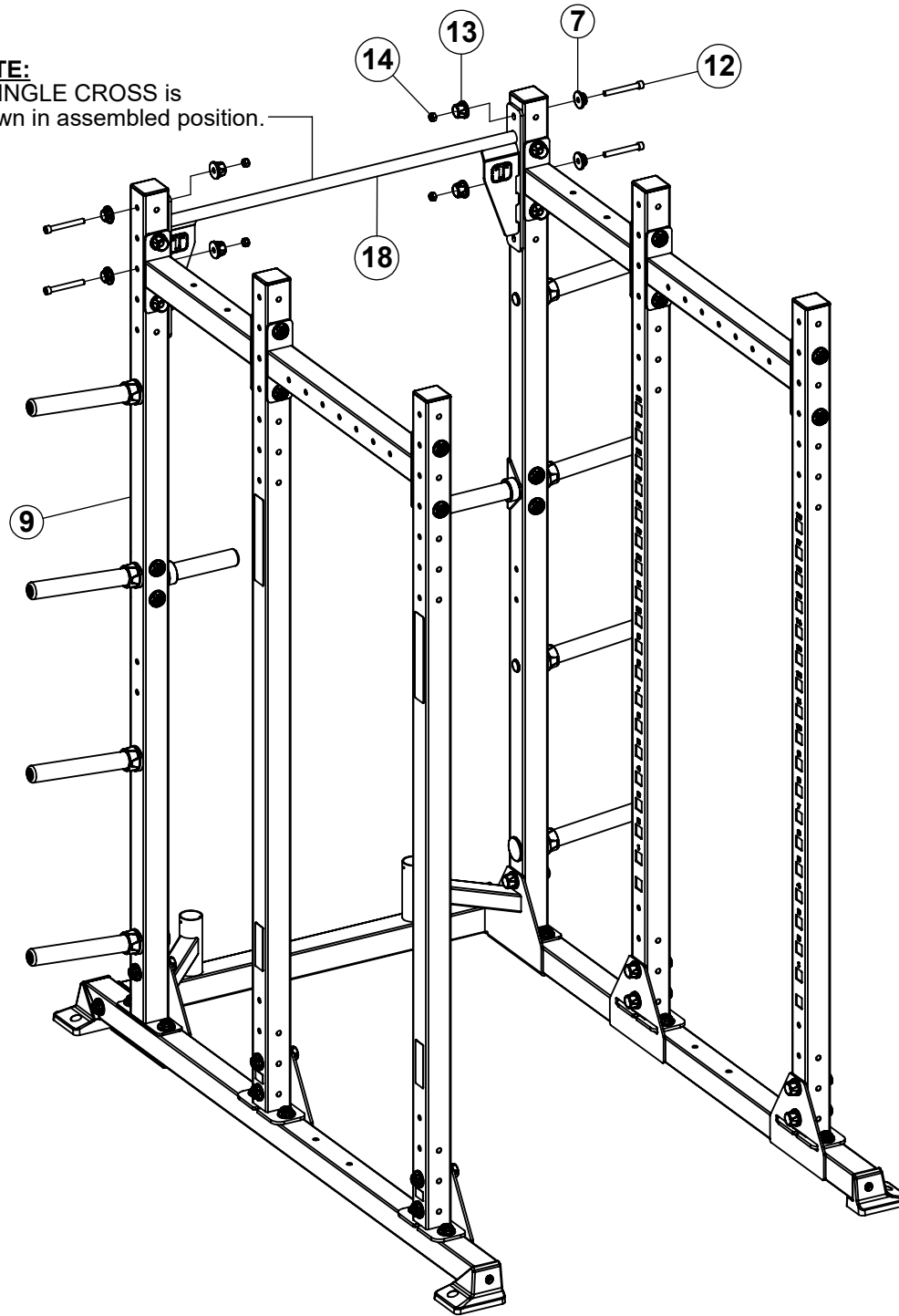

NOTE:

LOOSELY assemble bolt connections in this step.

STEP 9

NOTE:
REAR UPPER CROSS is
shown in assembled position.

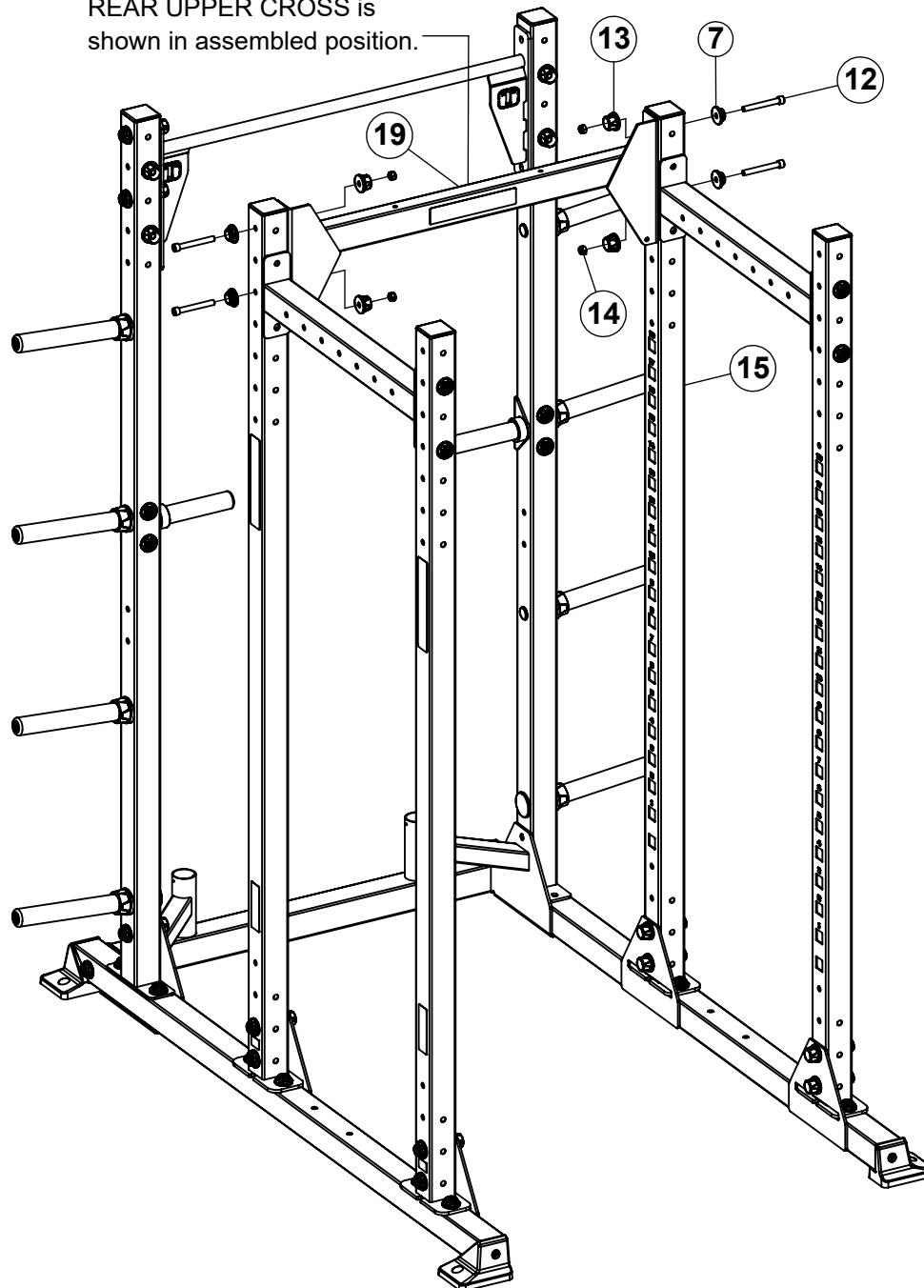

NOTE:

LOOSELY assemble bolt connections in this step.

STEP 10

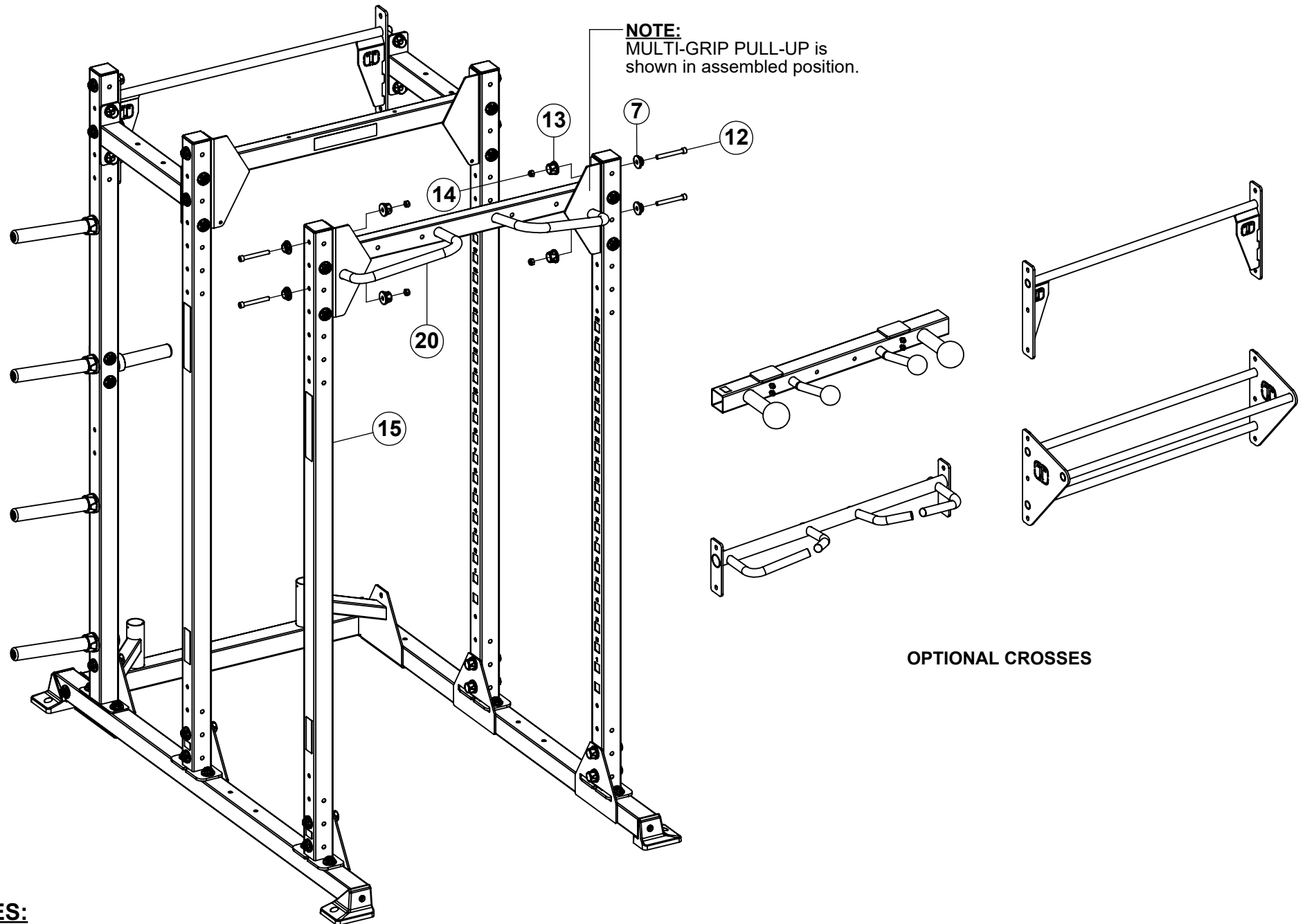

NOTES:

- **LOOSELY** assemble bolt connections in this step.
- Some items have been hidden for assembly clarity.

FRAME BOLT TIGHTENING SEQUENCE

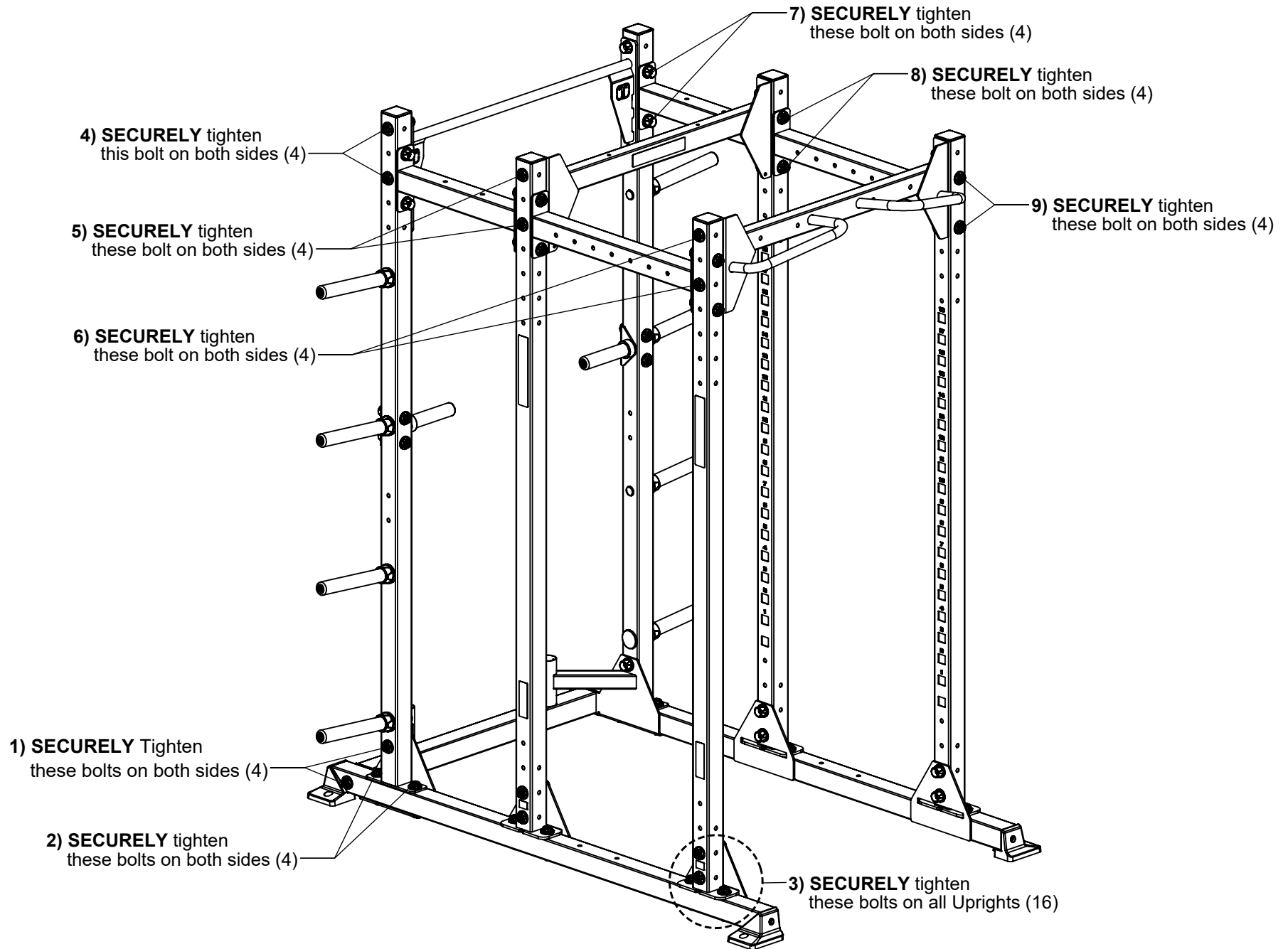

NOTE:

SECURELY tighten all bolt connections in order shown above.

ANCHORING

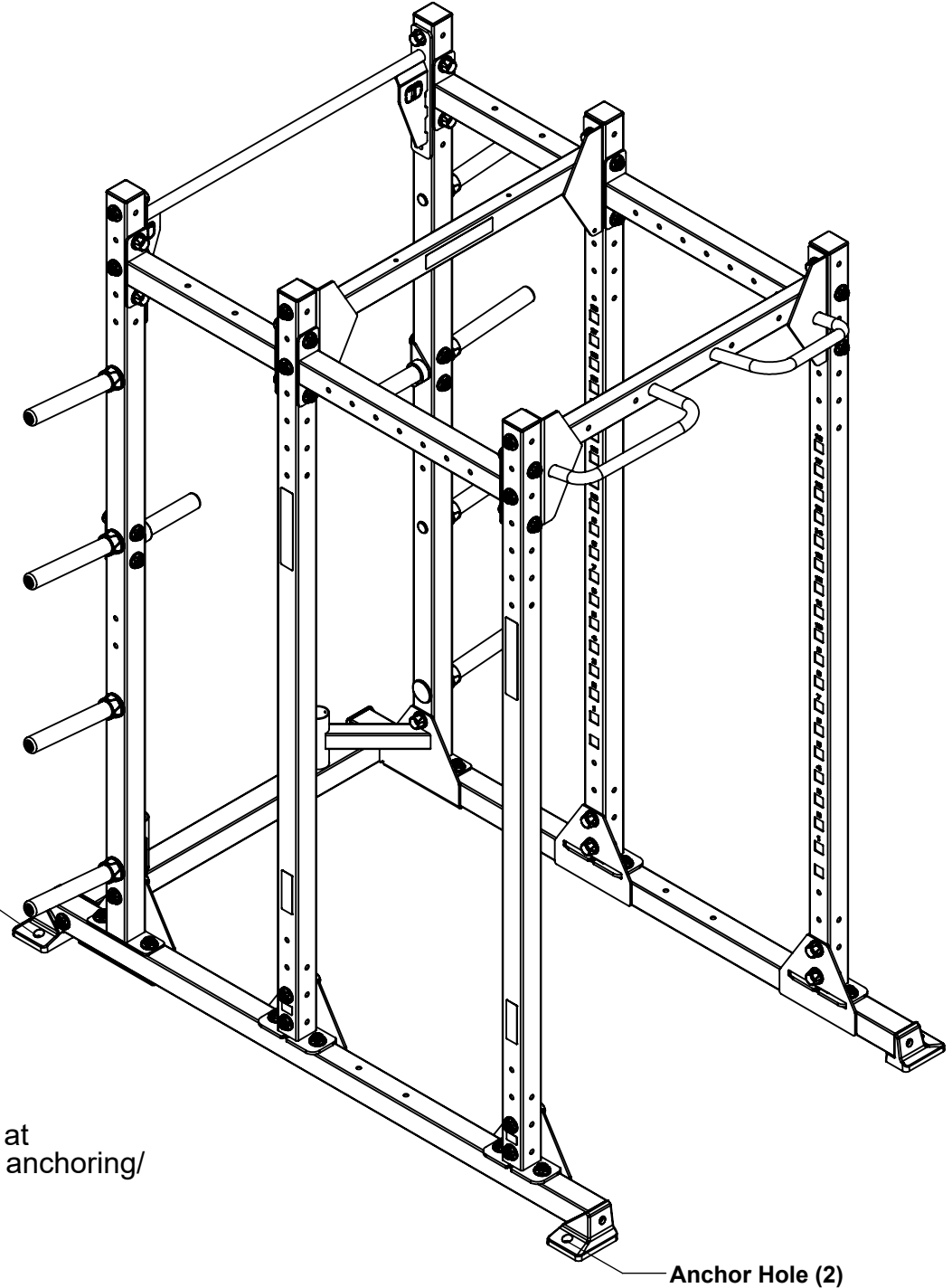

NOTES:

Make sure all bolts are **SECURELY** tighten.

Position **POWER RACK** to desired location in the room.

Anchor **POWER RACK** to the floor referencing X-RACK ANCHORING INSTRUCTIONS which can be downloaded at www.torquefitness.com/pages/assembly-manuals/x-series-anchoring/x-series-floor-anchoring-inst

WARNING!

HALF RACKS ARE REQUIRED TO BE ANCHORED TO THE FLOOR TO PREVENT ROCKING OR TIPPING DURING USE.

STEP 13

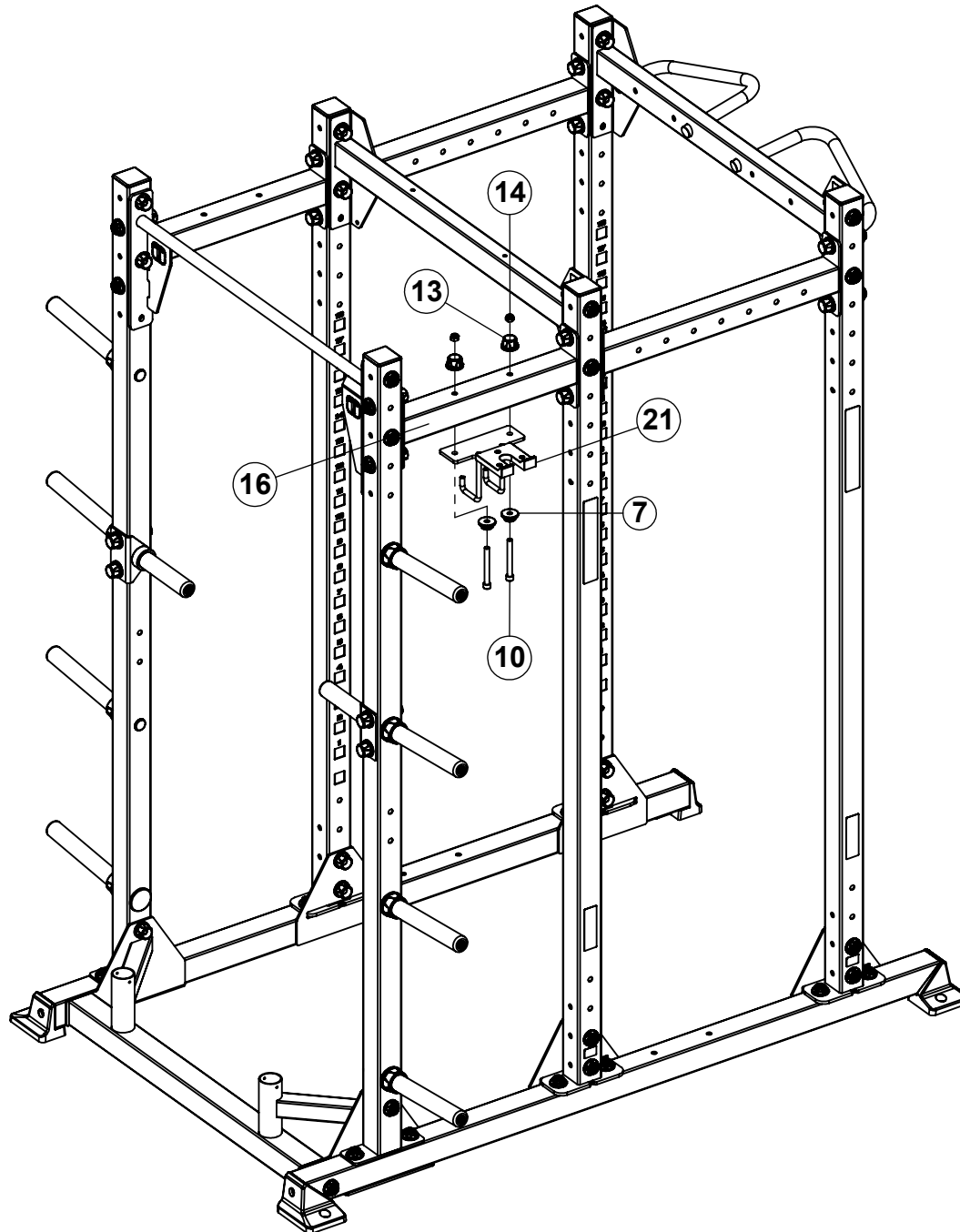

NOTES:

SECURELY tighten bolt connections in this step.

STEP 14

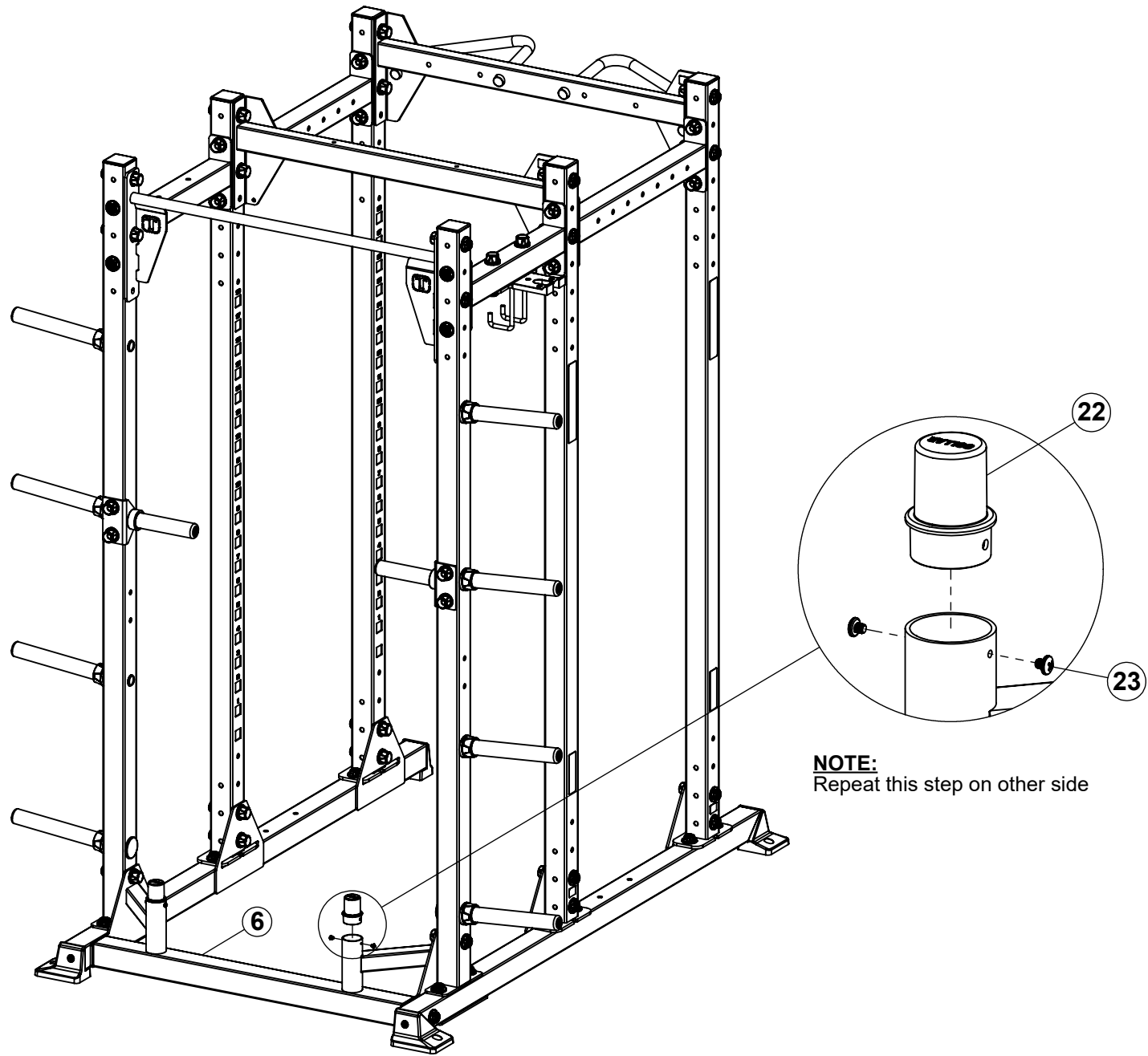

NOTE:
Repeat this step on other side

NOTES:

SECURELY tighten bolt connections in this step.

STEP 15

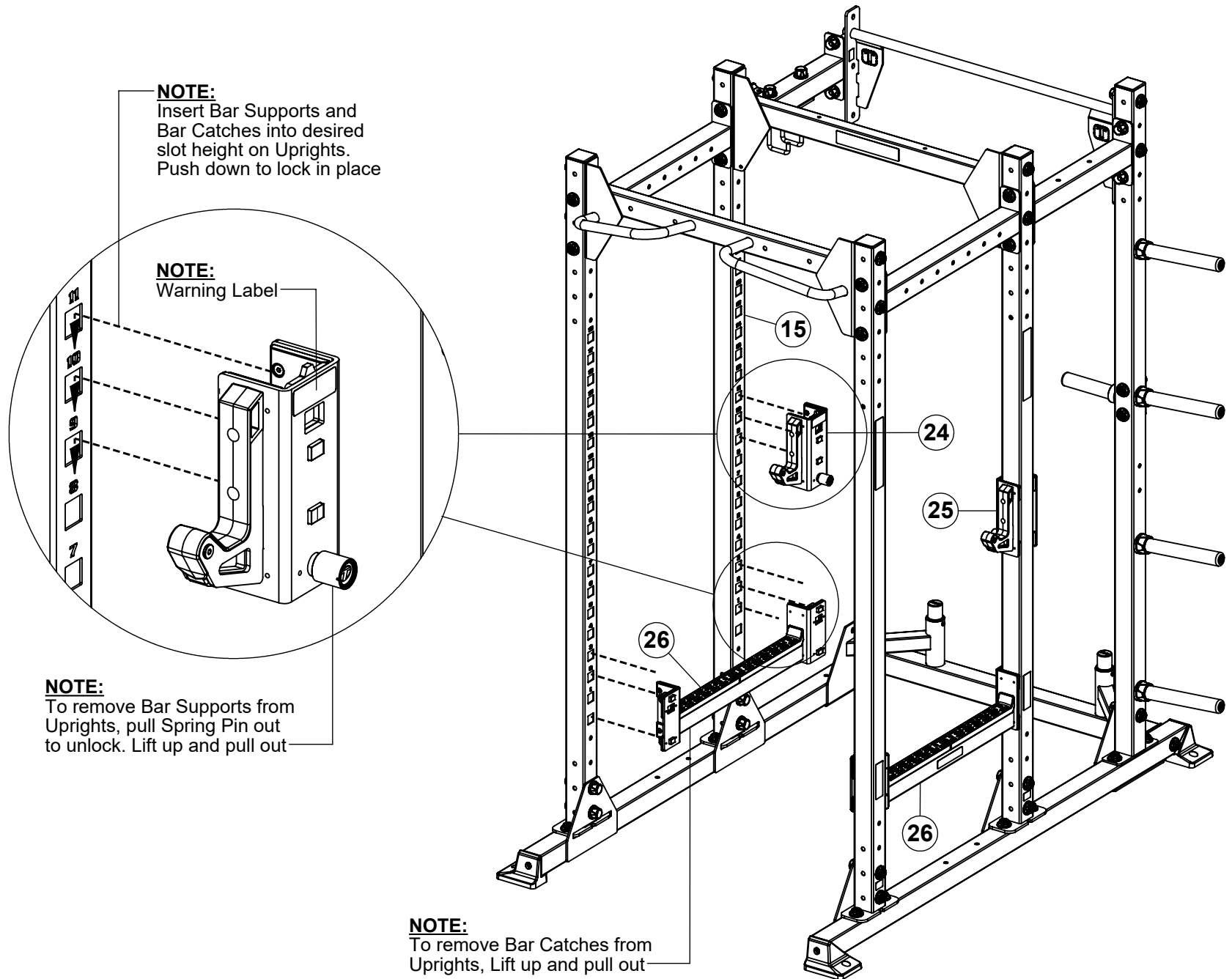

NOTE:

Some items have been hidden for assembly clarity.

WEIGHT STORAGE NUMBERING KIT

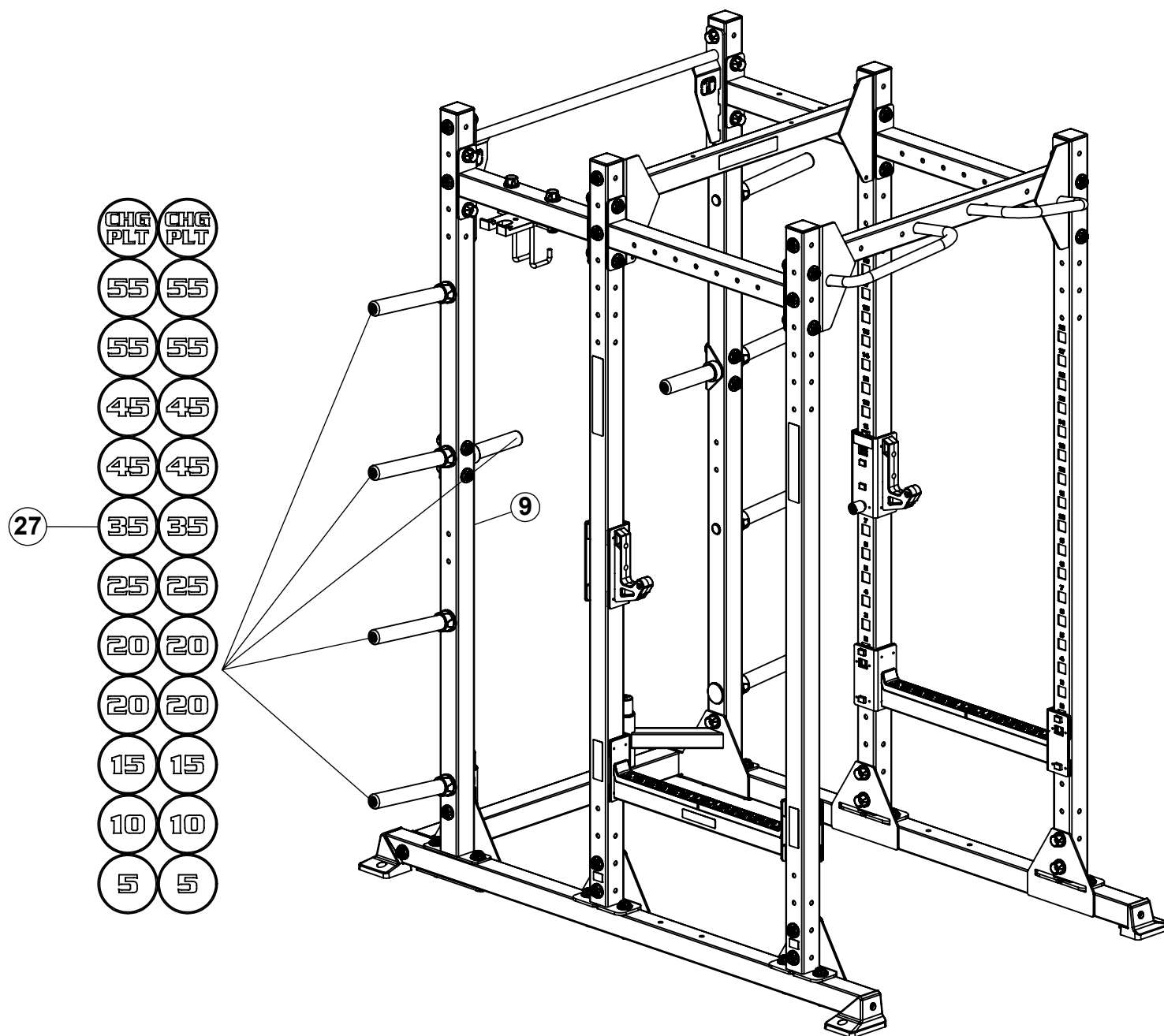

NOTE:

Using a rubber mallet, Install the desired WEIGHT STORAGE NUMBER CAP into the end of the WEIGHT HORN.

TR2 DOUBLE POWER RACK WITH STORAGE ASSEMBLY GUIDE

VERSION: DPRWS-101

PART #: 5929801-C

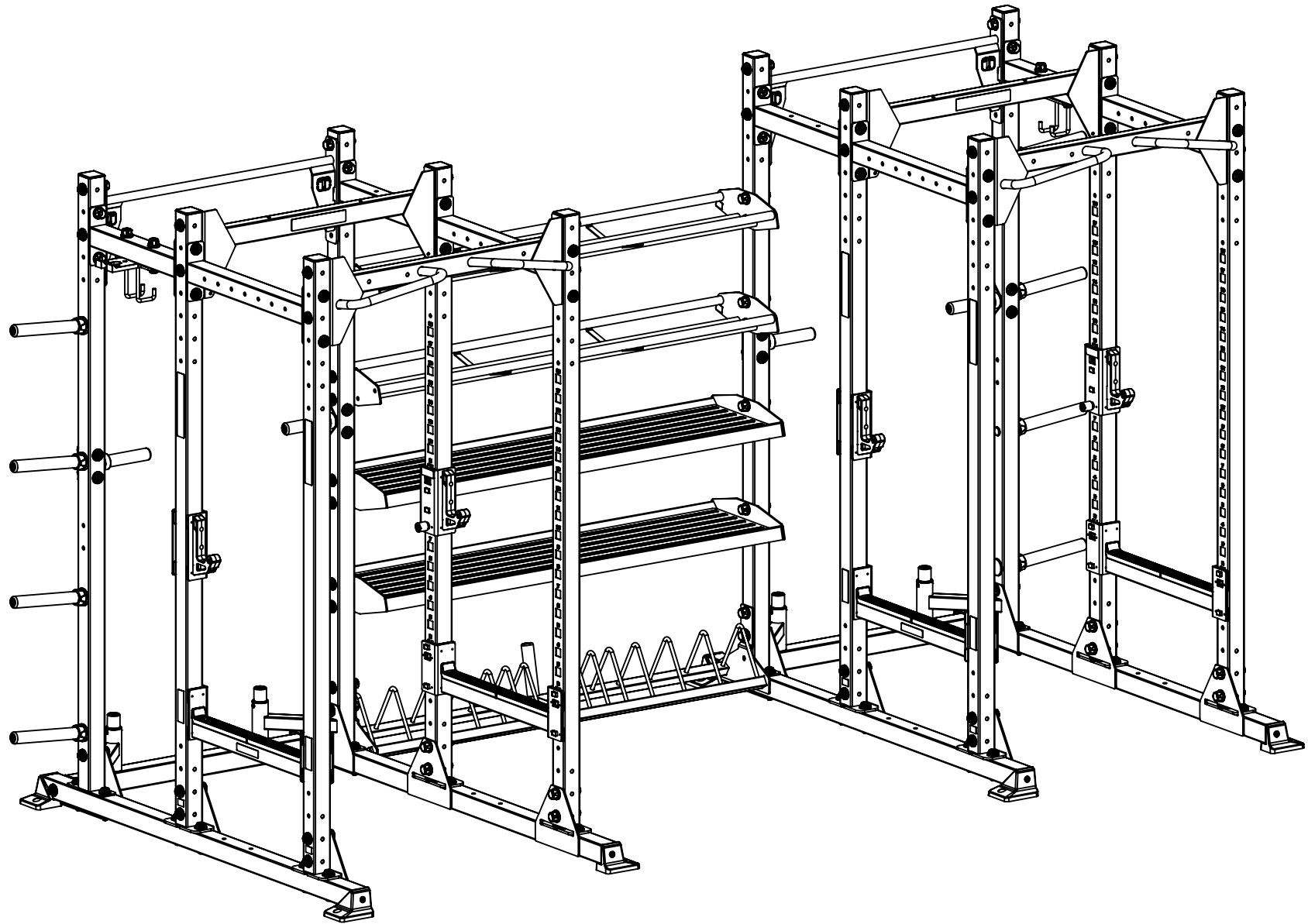

ITEM NO.	PART NUMBER	DESCRIPTION	QTY.
1	5884301	WLDMT, PR LEFT BASE	2
2	5872801	CASTING, BASE FOOT 2	4
3	5872701	CASTING, BASE FOOT 1	4
4	5884501	WLDMT, PR RIGHT BASE	2
5	2006803	SHCS, 1/2-13 X 1, CZ PATCH	8
6	5873101	WLDMT, REAR BASE CONNECTOR	2
7	5631801	WASHER COVER, NYLON BOLT	118
8	2006815	BOLT, 1/2-13 X 4" (102mm) SOCKET HEAD W/NP	4
9	58737PA	PTD ASSY, WEIGHT HORN UPRIGHT	2
10	58741PA	PTD ASSY, ACCESSORY STORAGE UPRIGHT	2
11	2005816	BOLT, 1/2-13 X 4-1/4" (108mm) SOCKET HEAD	28
12	2021001	NUT, 1/2-13 HEX FLG LK ST ZN	24
13	2005815	BOLT, 1/2-13 X 4" (102mm) SOCKET HEAD	86
14	5631901	WASHER COVER, NYLON NUT	90
15	2001401	NUT, 1/2-13 LK ST ZN	90
16	57291PA	PTD ASSY, 6' BUMPER BOOKSHELF STORAGE	1
17	58274PA	PTD ASSY, 8' UPRIGHT	8
18	5874301	WLDMT, UPRIGHT CONNECTOR	4
19	5884601	WLDMT, PR FRONT UPRIGHT CONNECTOR	4
20	5442801	WLDMT, 4' SINGLE CROSS	2
21	58754PA	PTD ASSY, REAR UPPER CROSS	2
22	58749PA	PTD ASSY, MULTI-GRIP PULL-UP	2
23	58745PA	PTD ASSY, OLYMPIC BAR HOLDER	2
24	5876401	CAP, END-COLLAR HOLDER	4
25	2045201	PPMS, 1/4-20 X 1/4, BO, SS	8
26	58129PA	PTD ASSY, 6 FT ACCESSORY TRAY	2
27	5729001	MAT, 6' ACCESSORY TRAY	2
28	58469PA	PTD ASSY, 6' BALL STORAGE	2
29	59167PA	PTD ASSY, LEFT BAR SUPPORT	2
30	59166PA	PTD ASSY, RIGHT BAR SUPPORT	2
31	58848PA	PTD ASSY, PR BAR CATCH	4
32	WSNK5-55-101	WEIGHT STORAGE NUMBERING KIT 5-55	1

NOTE:

To assemble DOUBLE HALF RACK follow the steps on pages 25 through 44. Optional attachments, pages 45 through 48.

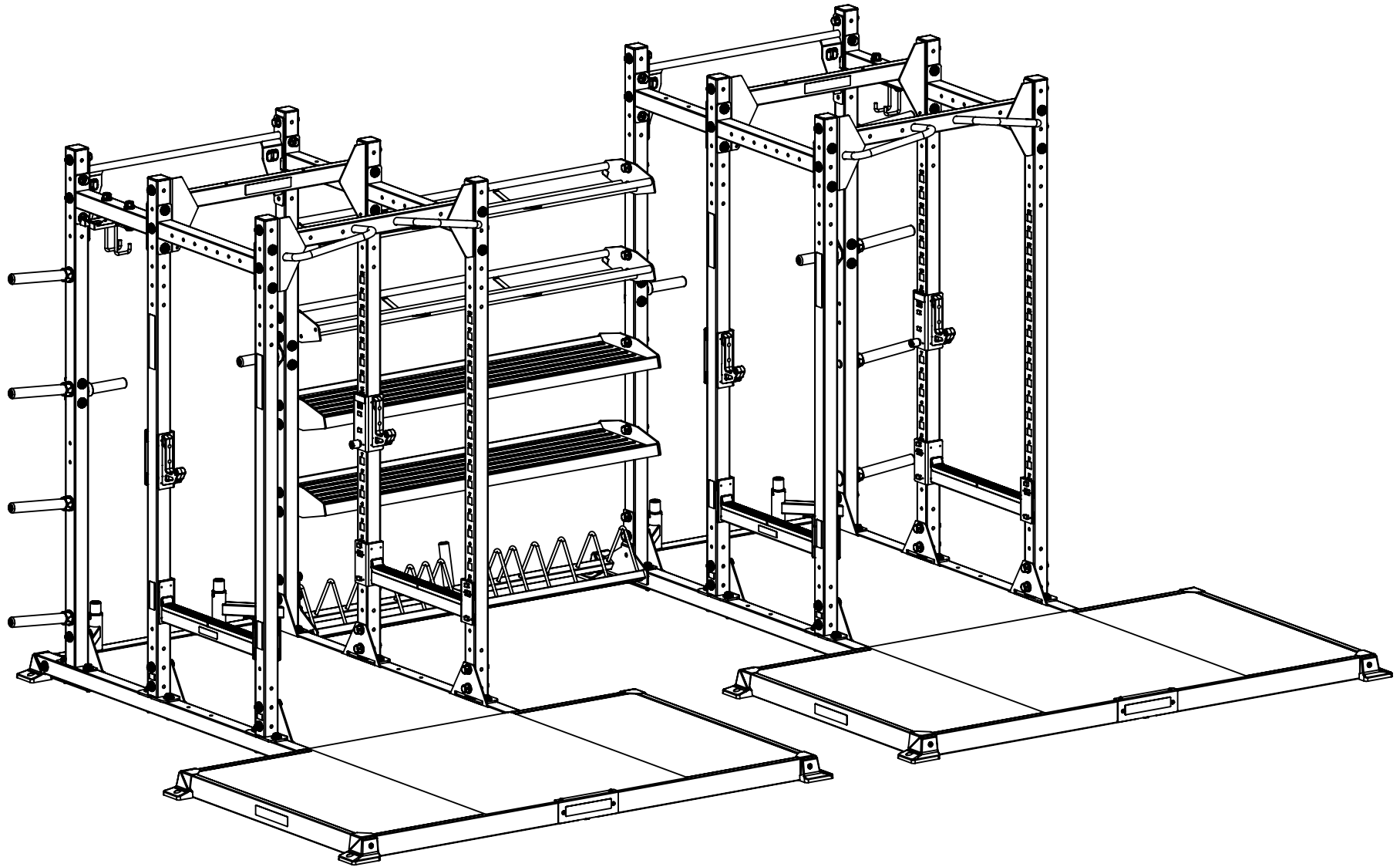

NOTE:

If assembling Platform at the same time as Double Power Rack, please refer to the Platform Instructions first, then proceed with these instructions skipping steps 1 and 2 and starting with step 3.

STEP 1

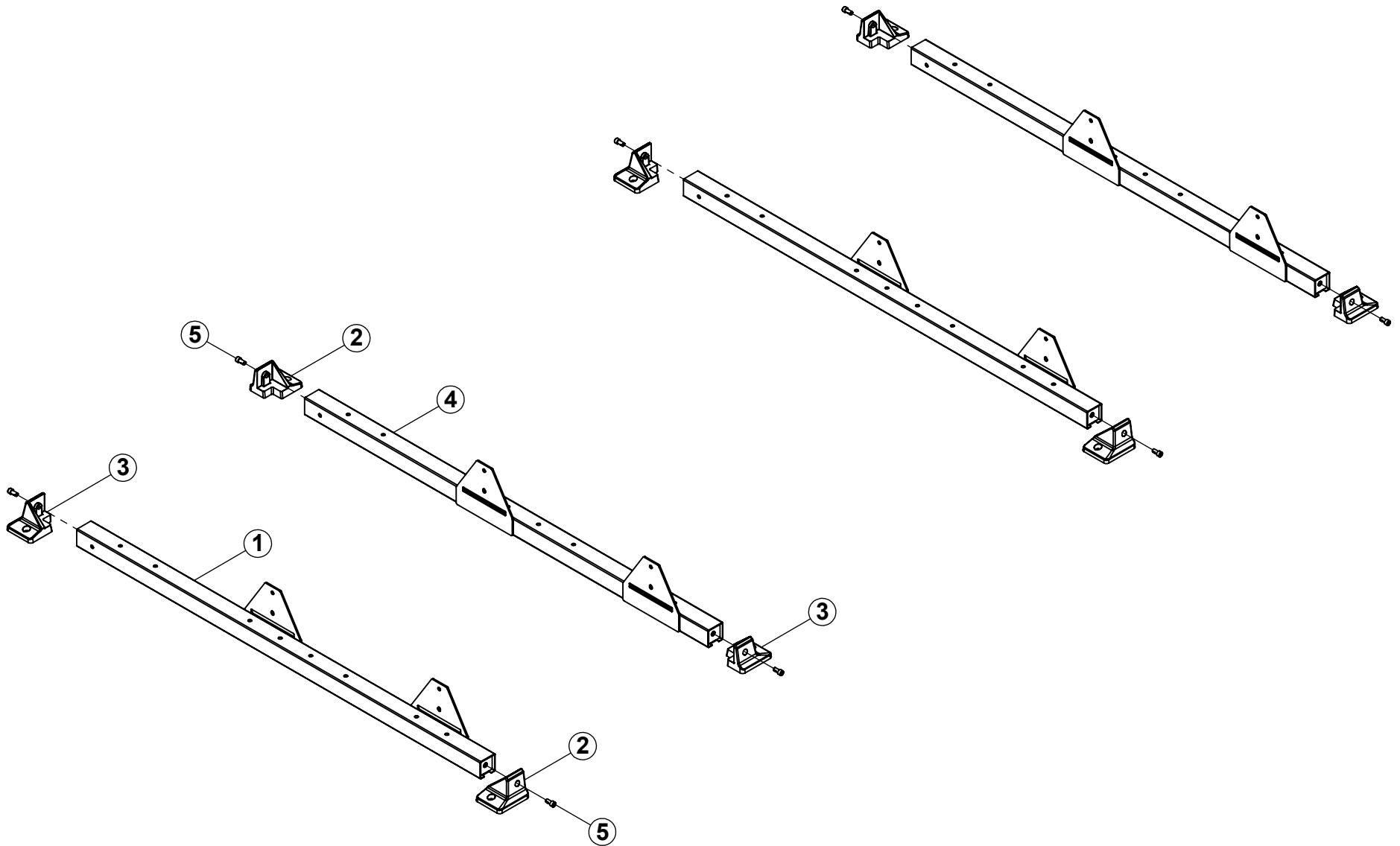

NOTE:

SECURELY tighten all bolt connections in this step.

STEP 2

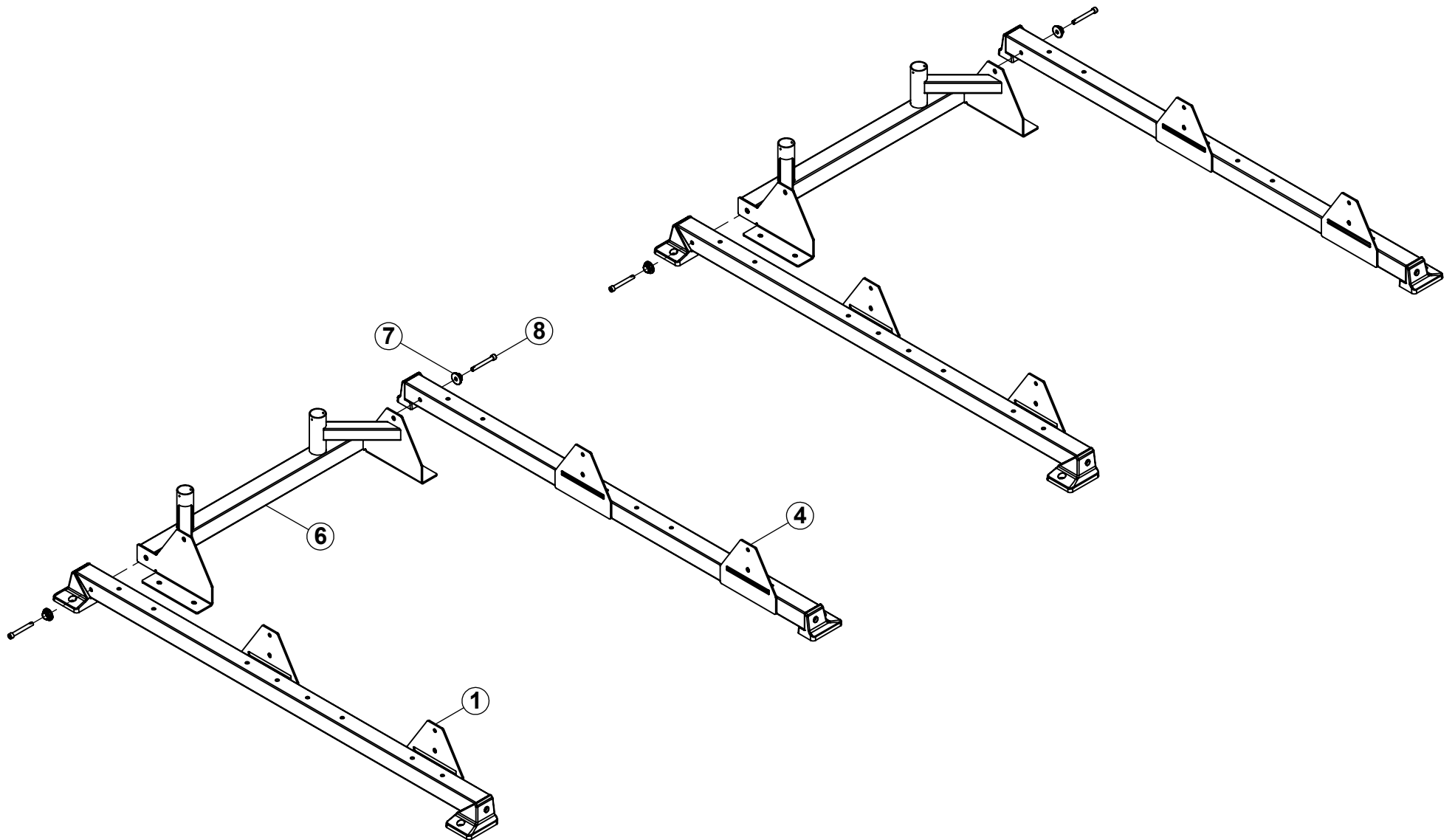

NOTE:

LOOSELY assemble bolt connections in this step.

STEP 3

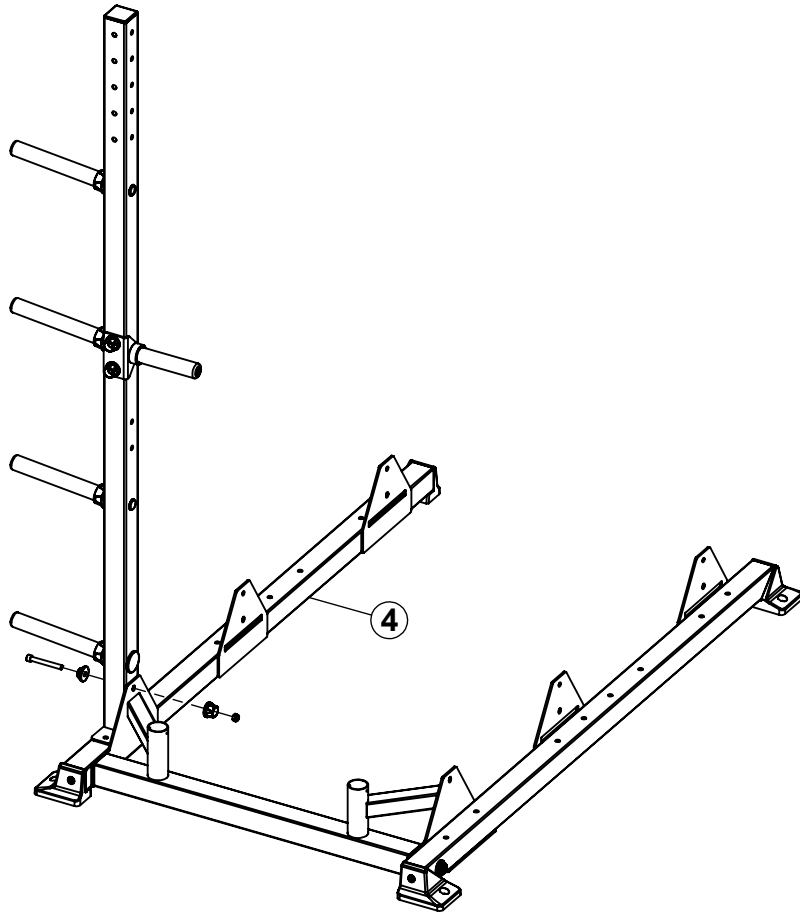

NOTE:
WEIGHT HORN UPRIGHT is shown in assembled position.

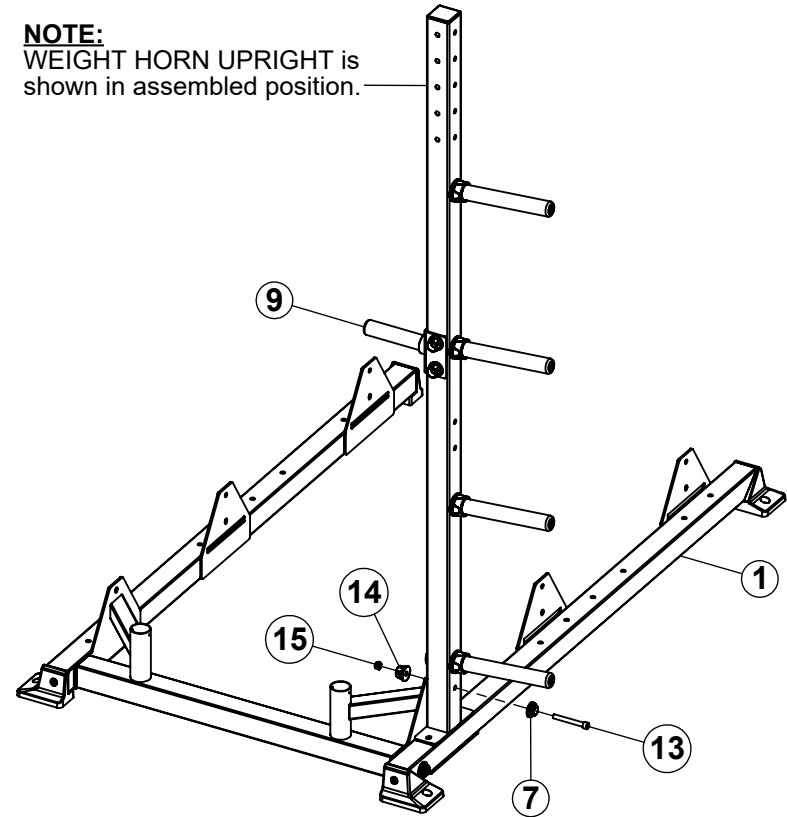

NOTE:

LOOSELY assemble bolt connections in this step.

STEP 4

NOTE:
ACCESSORY STORAGE UPRIGHT
is shown in assembled position.

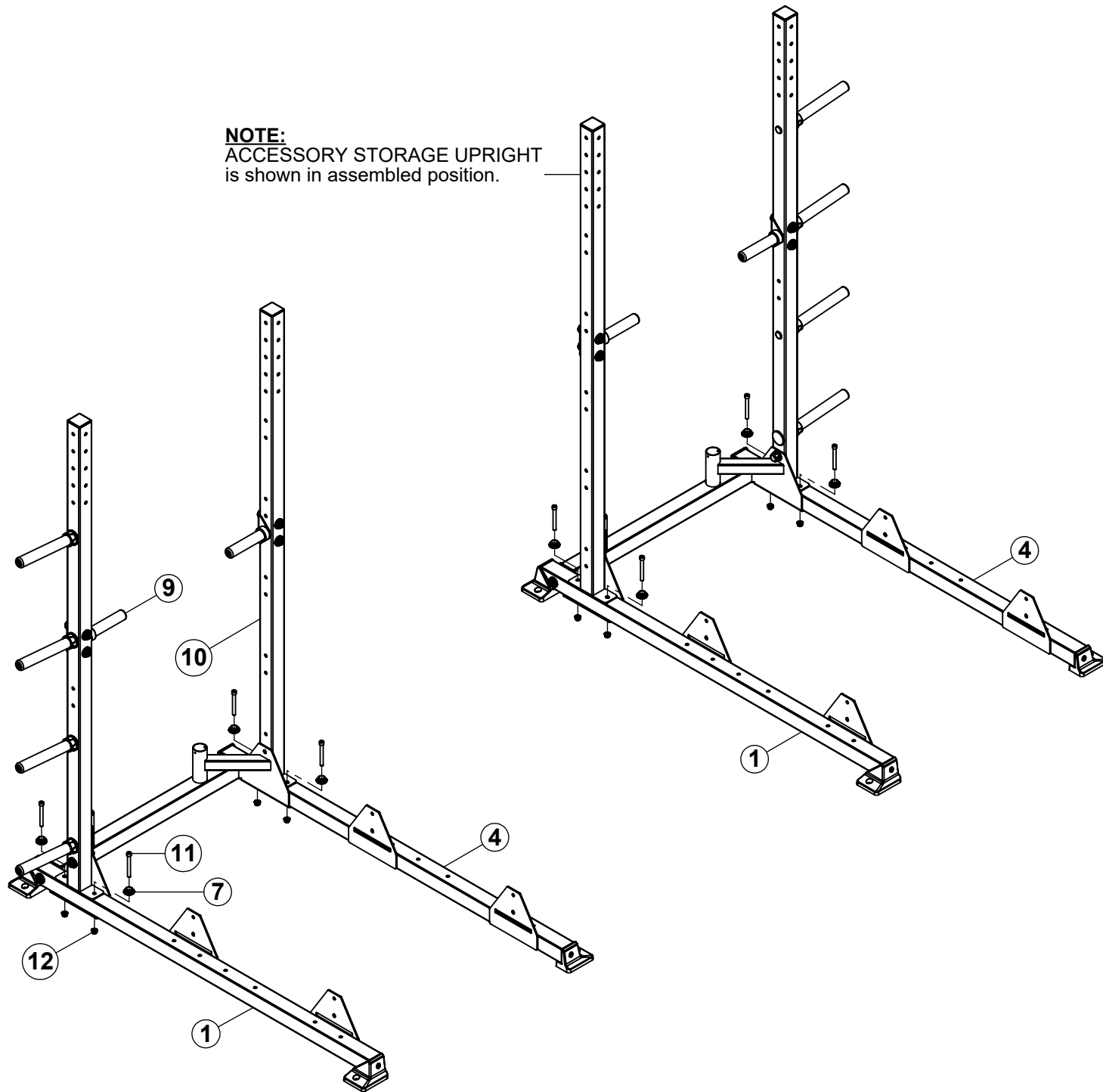

NOTE:

LOOSELY assemble bolt connections in this step.

STEP 5

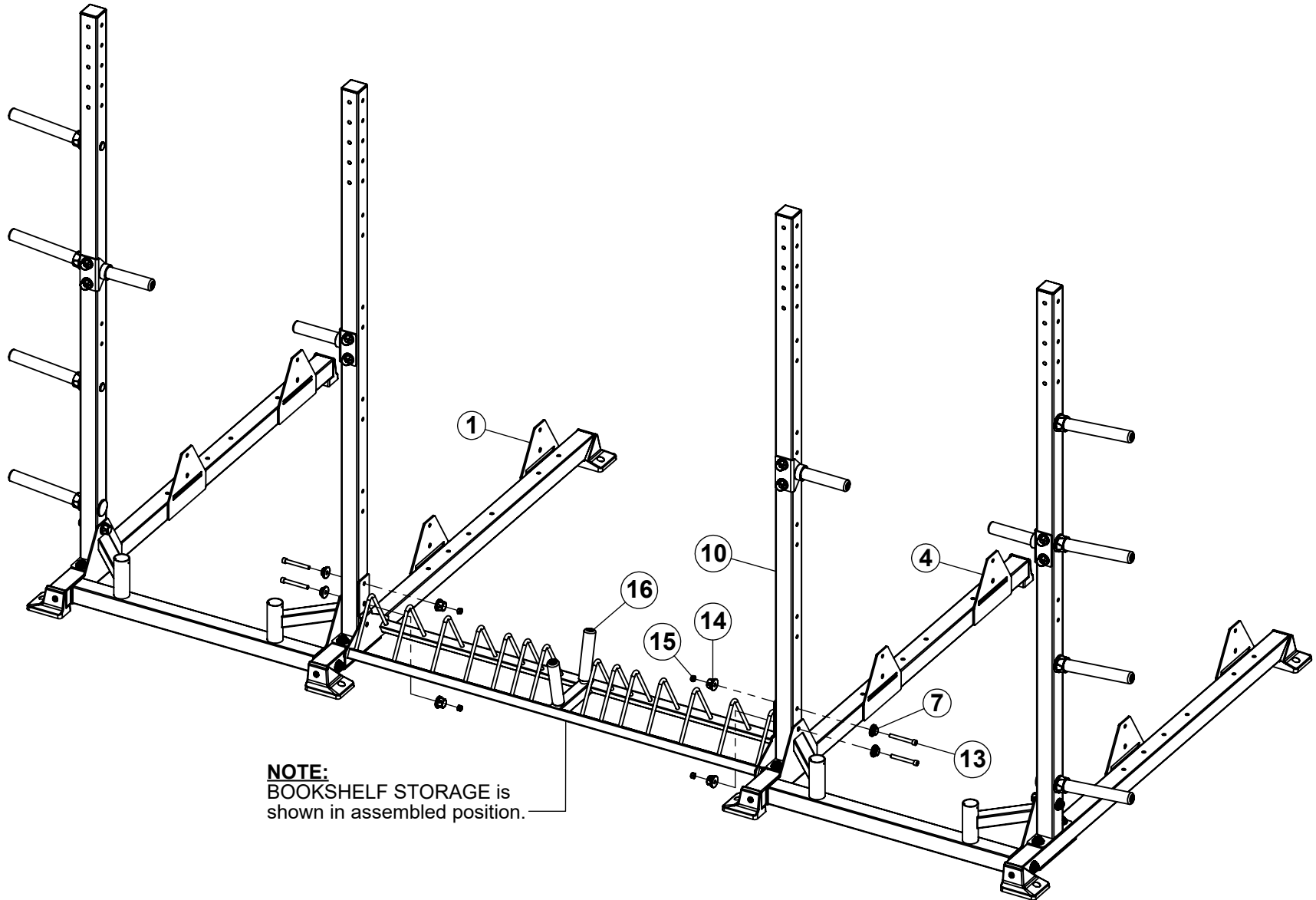

NOTE:
BOOKSHELF STORAGE is
shown in assembled position.

NOTE:

LOOSELY assemble bolt connections in this step.

STEP 6

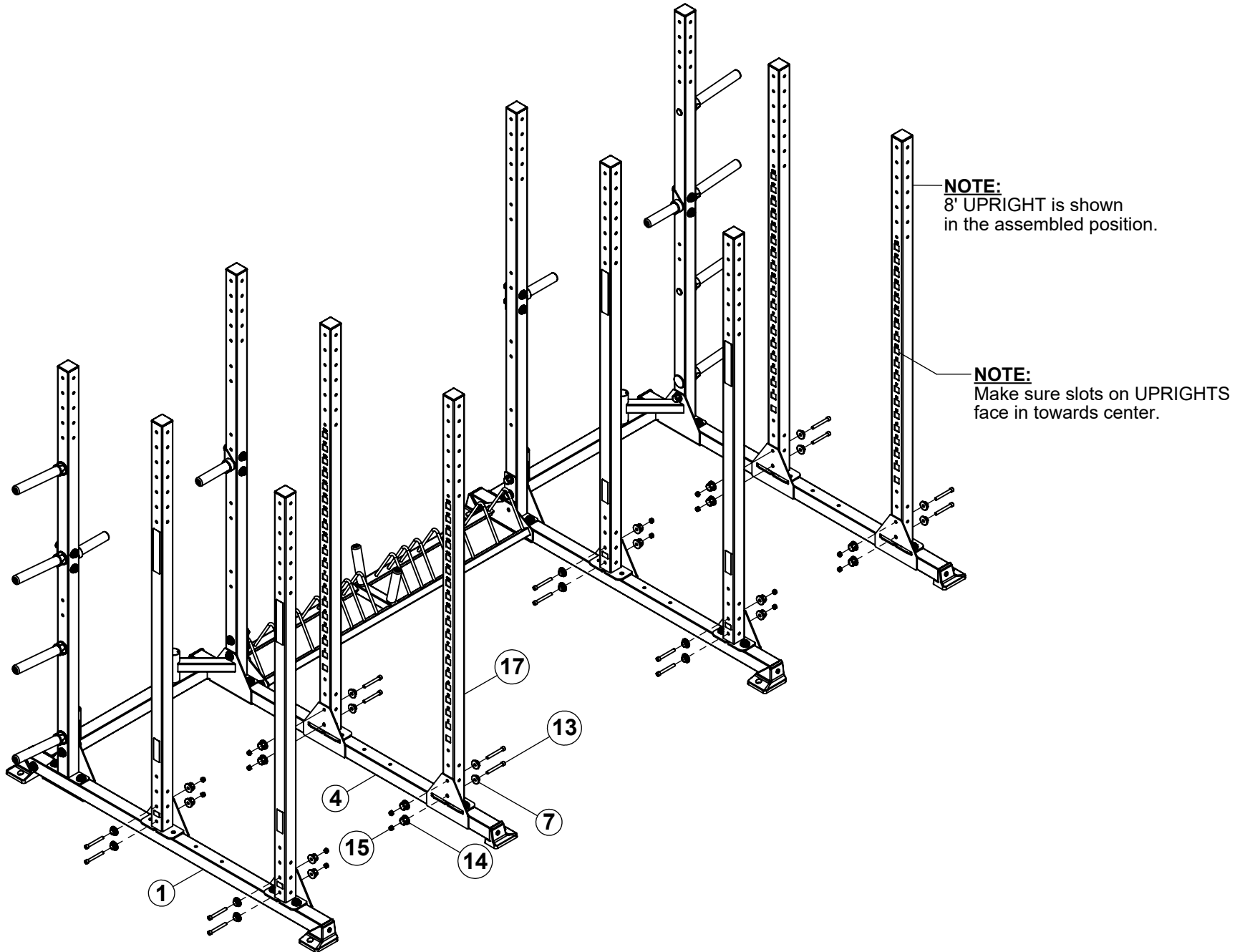

NOTE:

LOOSELY assemble bolt connections in this step.

STEP 7

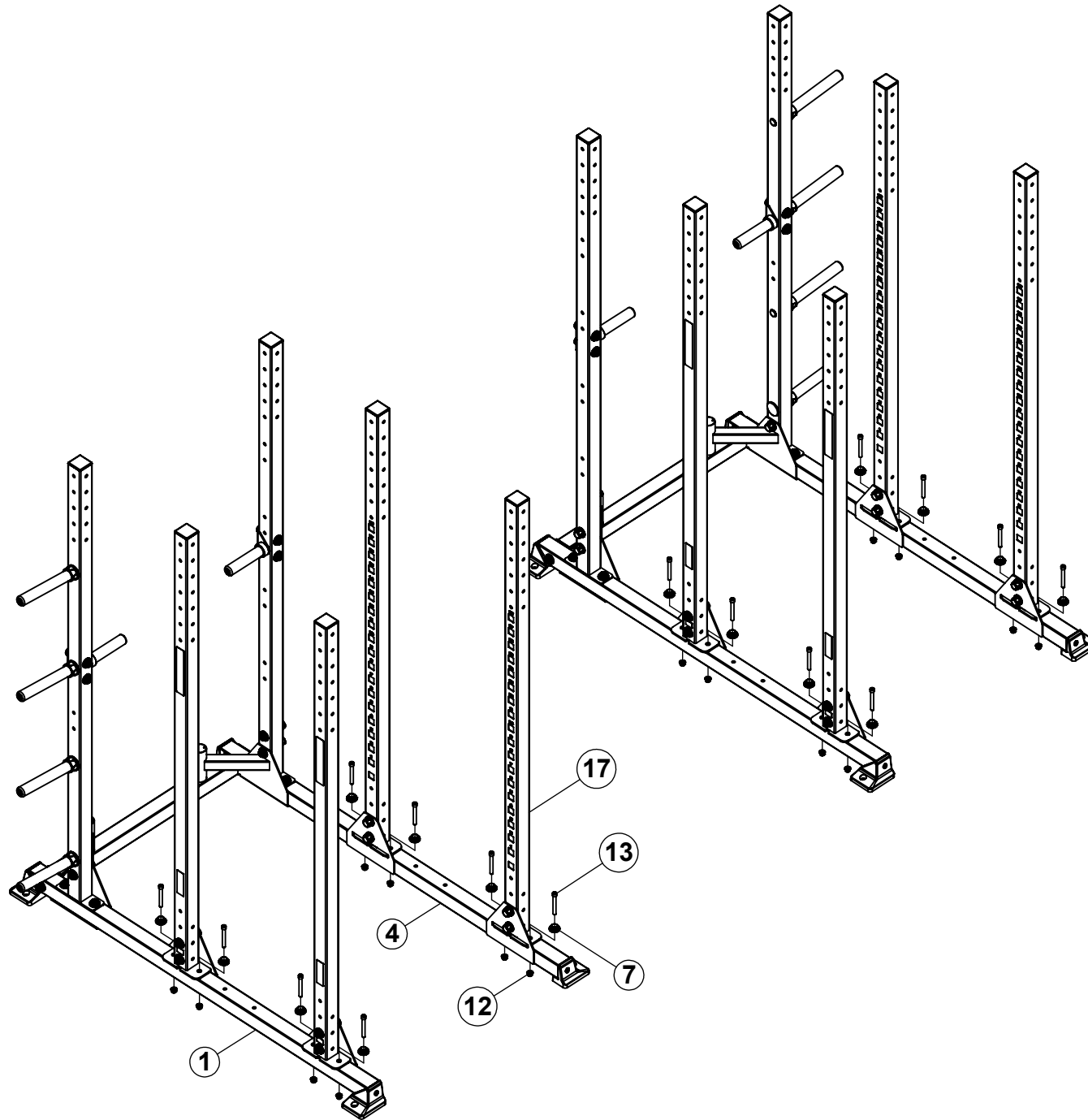

NOTES:

- **LOOSELY** assemble bolt connections in this step.
- The BOOKSHELF STORAGE has been hidden for assembly clarity.

STEP 8

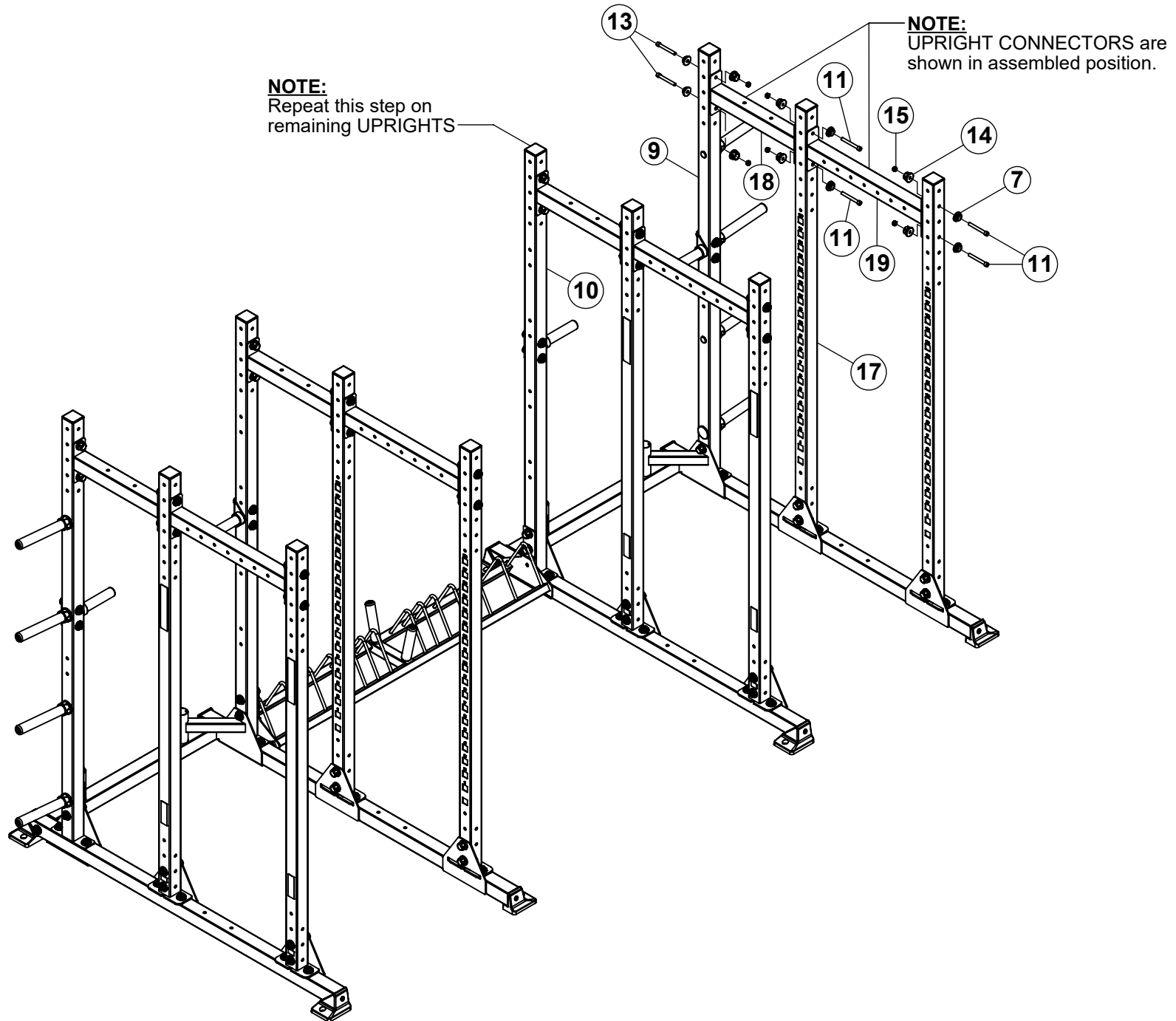

NOTE:

LOOSELY assemble bolt connections in this step.

STEP 9

NOTE:
4' SINGLE CROSSES are
shown in assembled position.

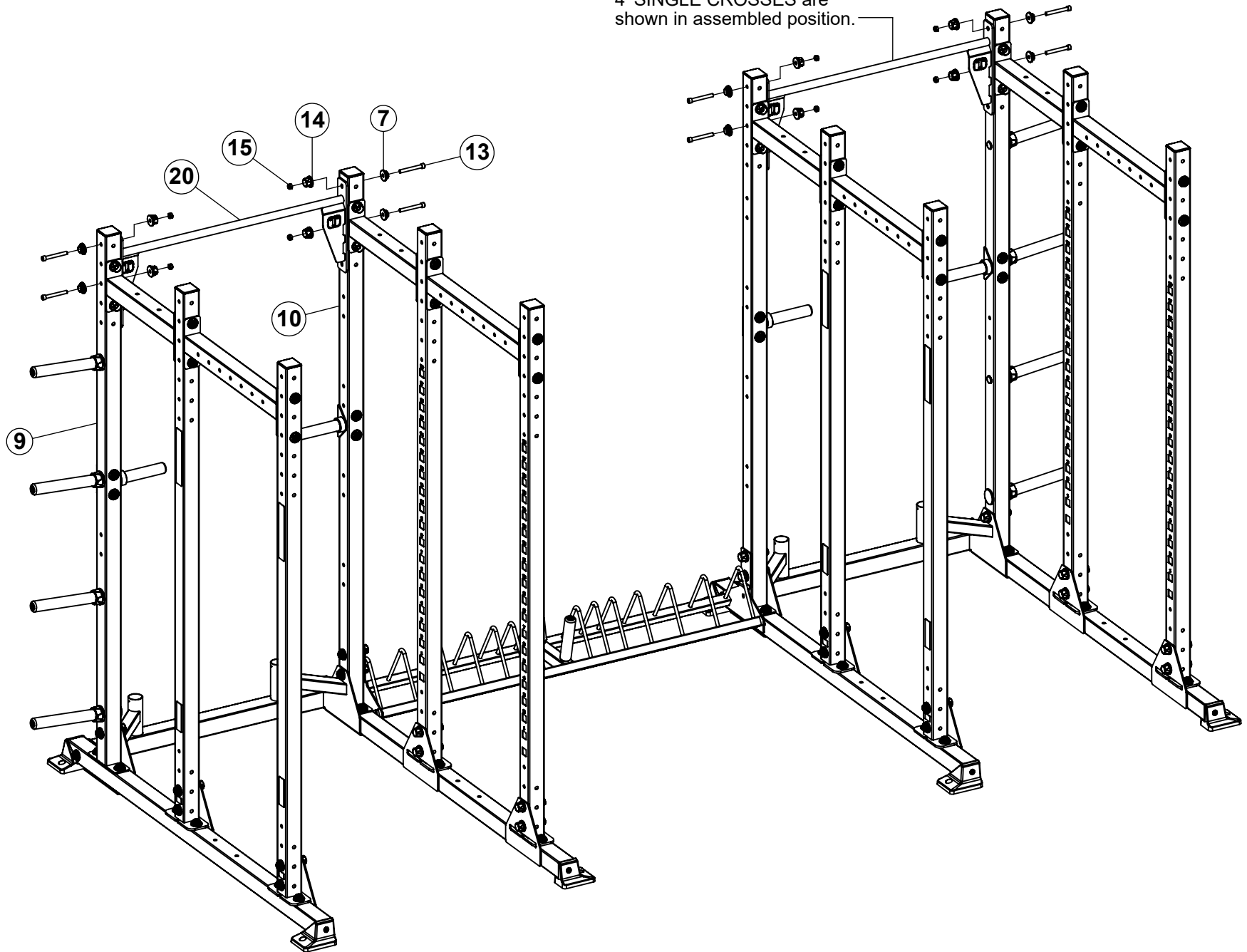

NOTE:

LOOSELY assemble bolt connections in this step.

STEP 10

NOTE:
UPPER CROSSES are
shown in assembled position.

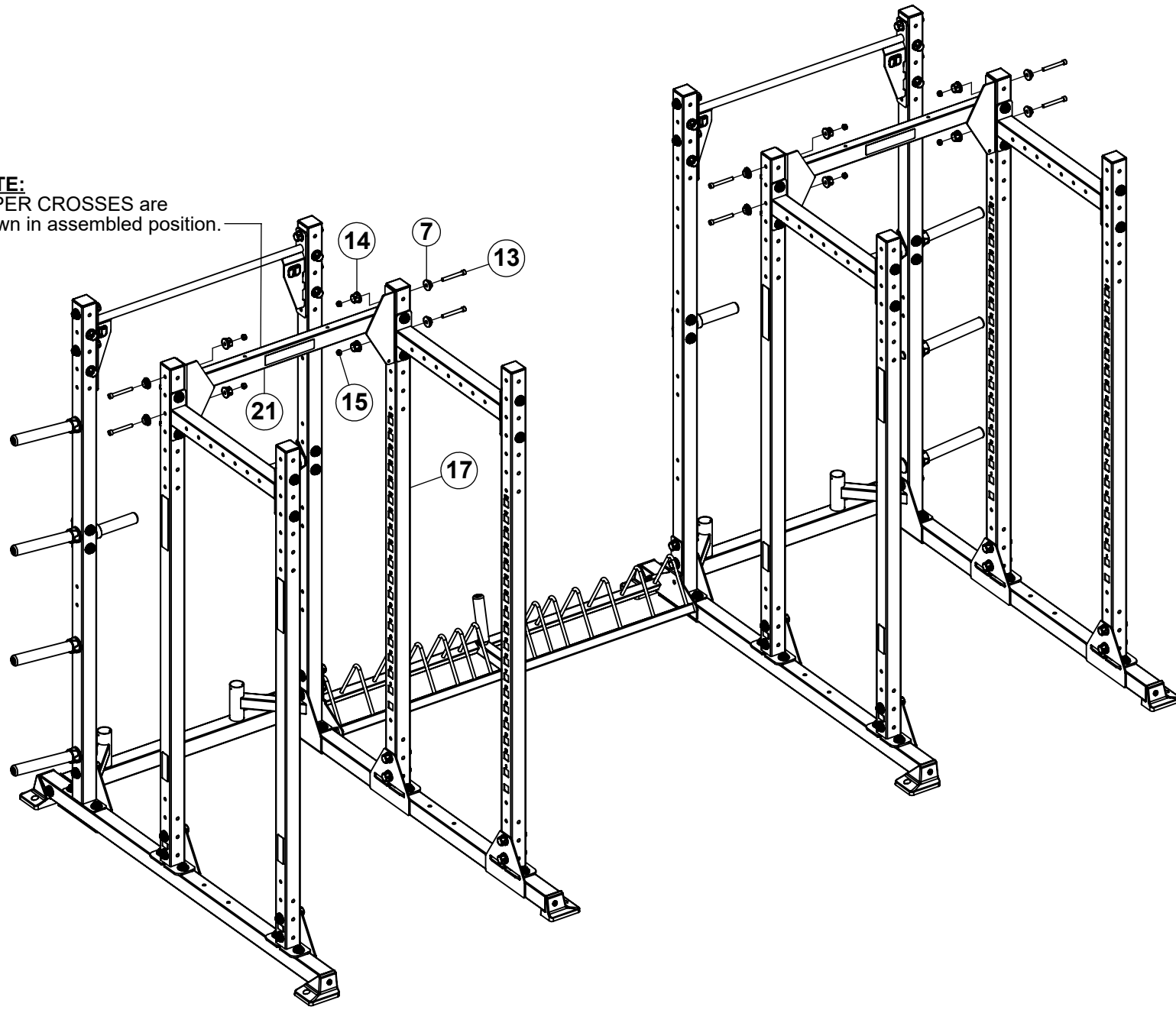

NOTES:

- **LOOSELY** assemble bolt connections in this step.
- Some items have been hidden for assembly clarity.

STEP 11

NOTE:
MULTI-GRIP PULL-UPS are shown in assembled position.

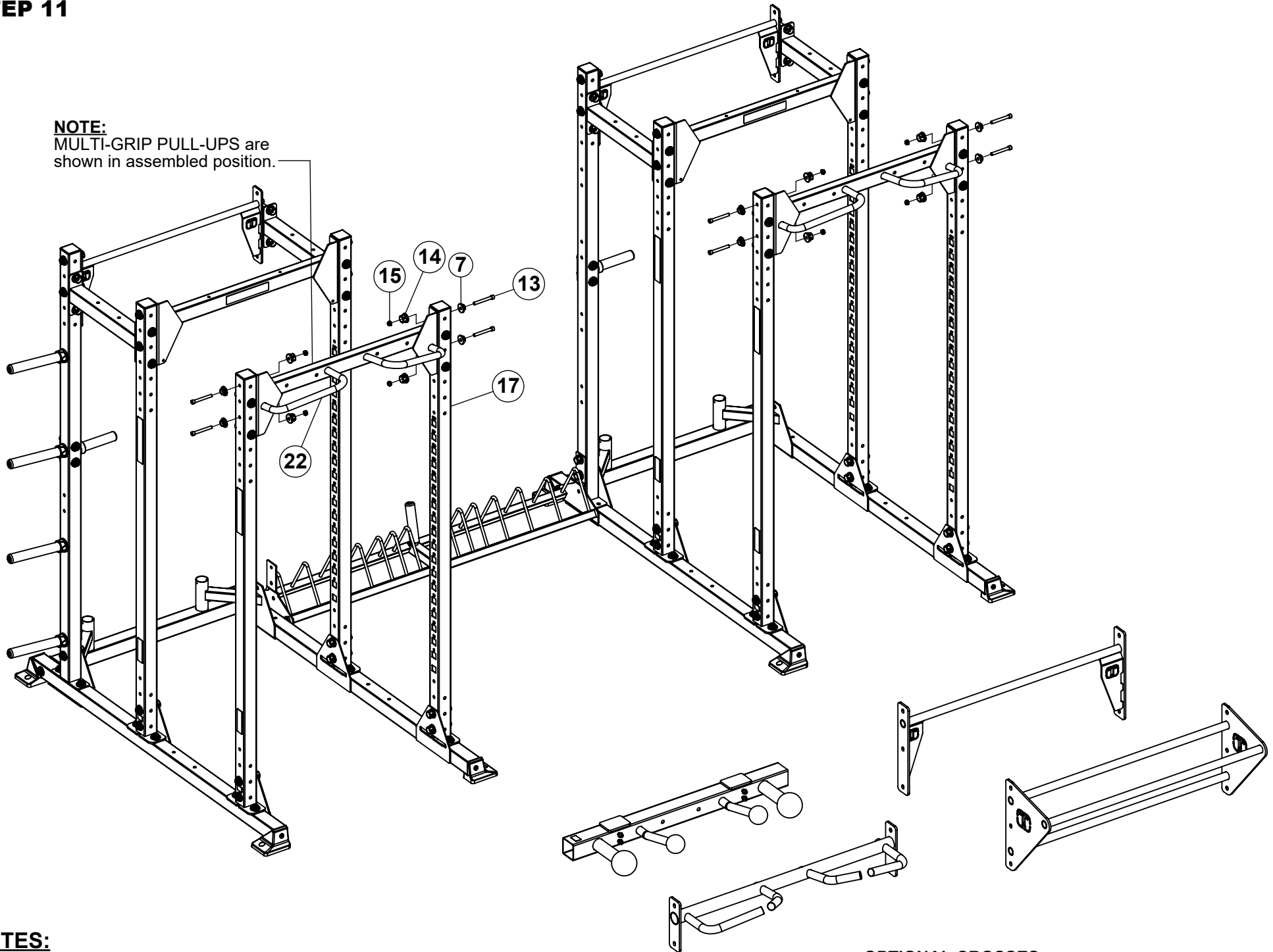

NOTES:

- **LOOSELY** assemble bolt connections in this step.
- Some items have been hidden for assembly clarity.

OPTIONAL CROSSES

STEP 12

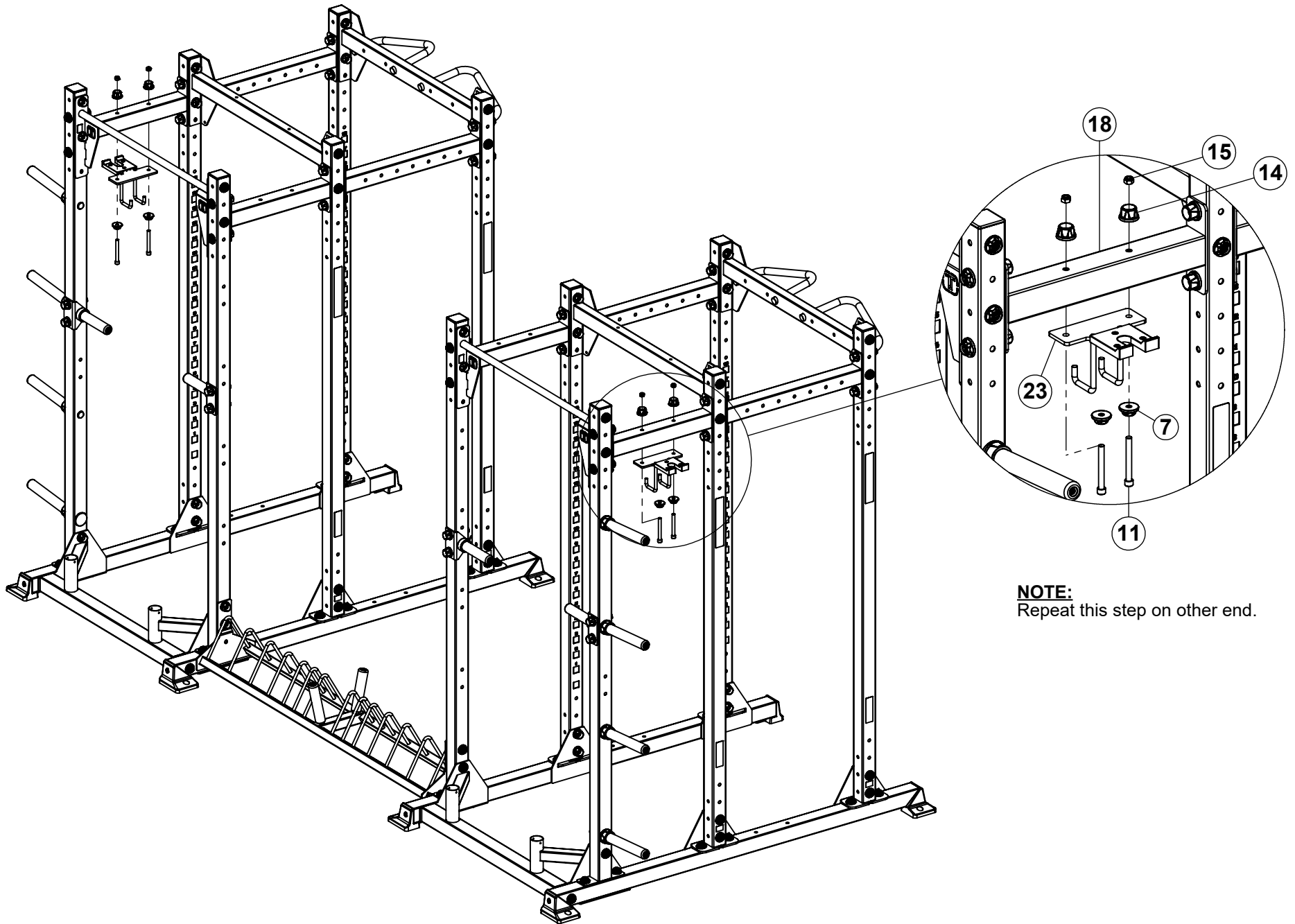

NOTE:
Repeat this step on other end.

NOTES:

SECURELY tighten bolt connections in this step.

STEP 13

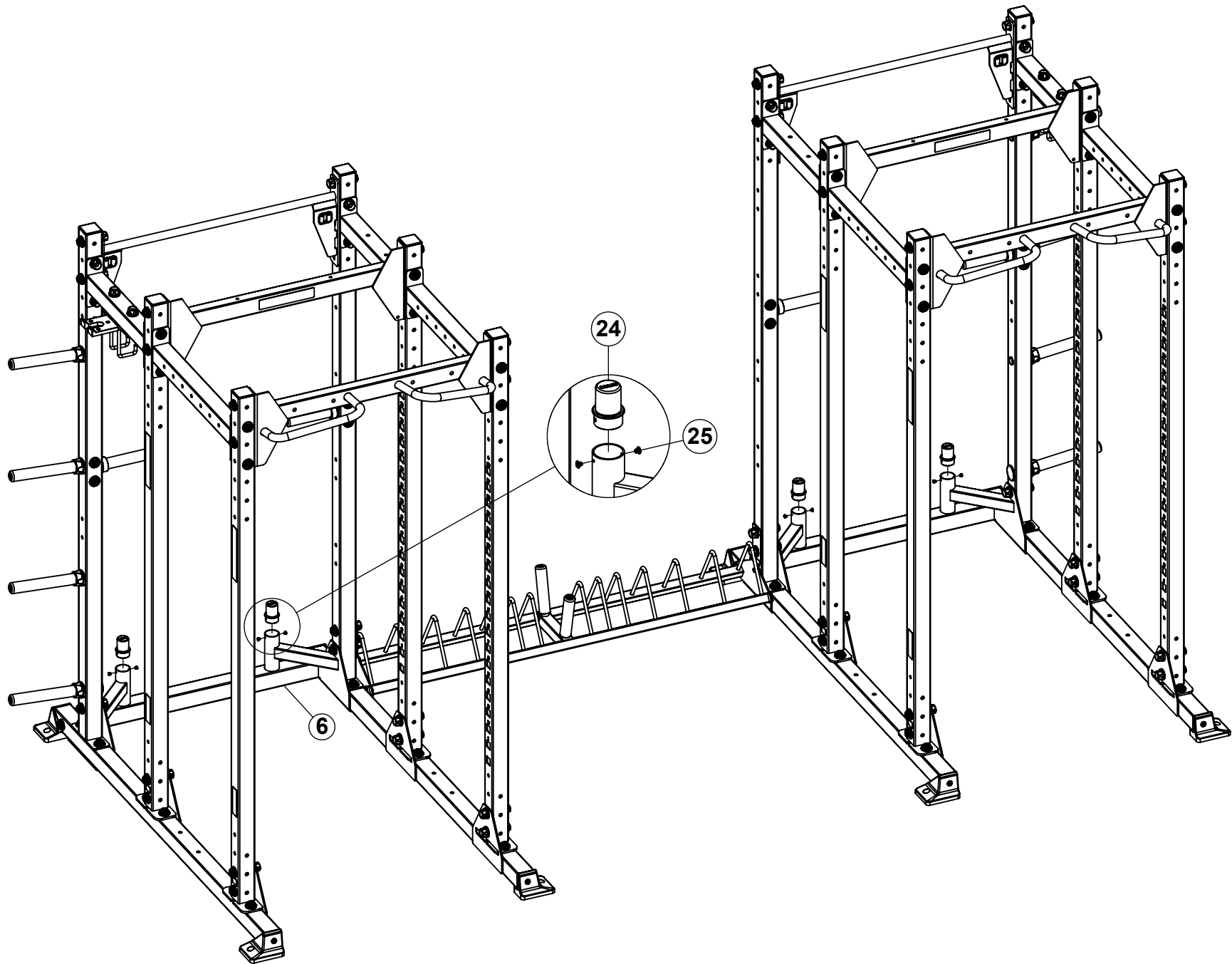

NOTE:

SECURELY tighten bolt connections in this step.

STEP 14

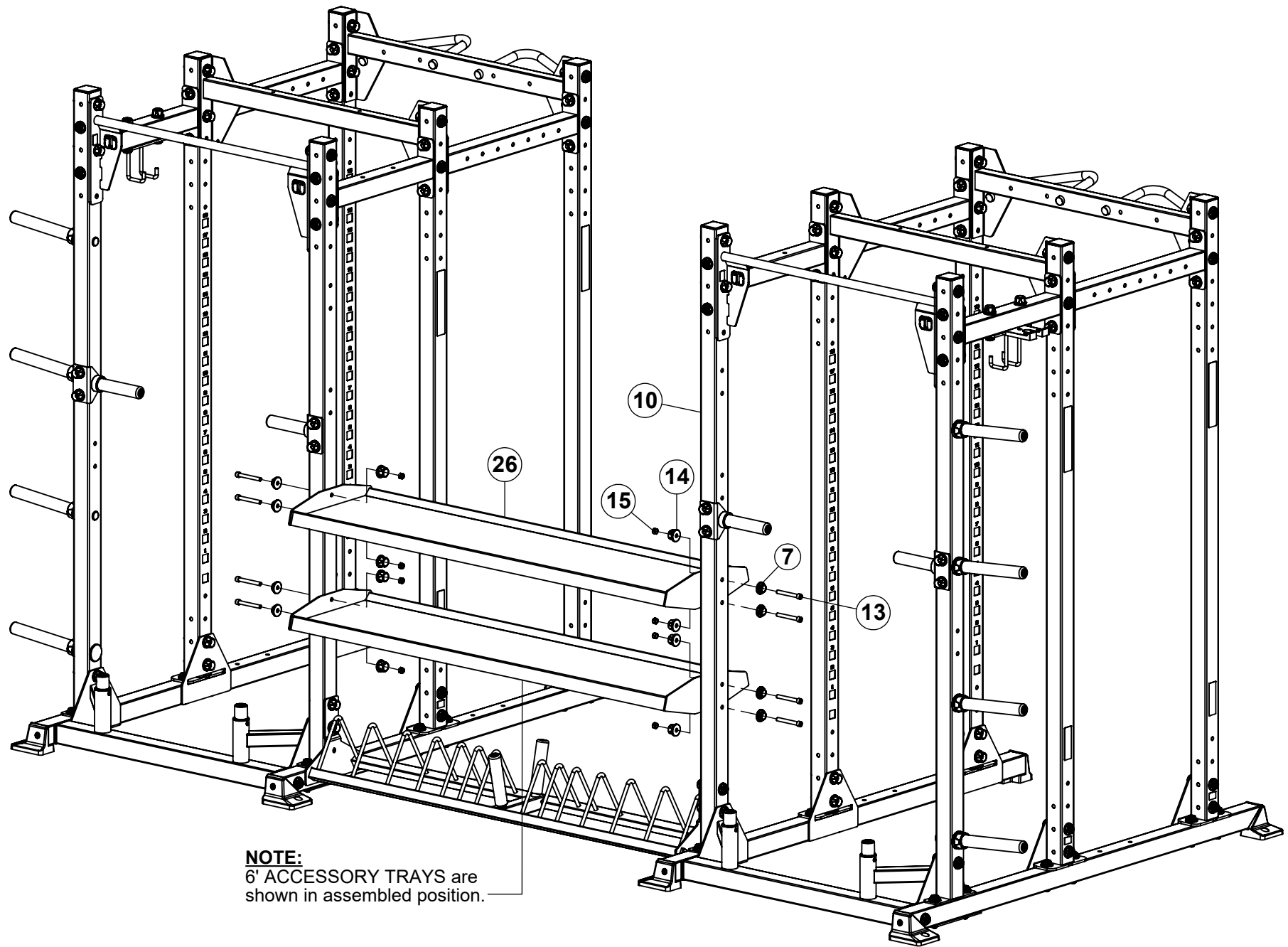

NOTE:
6" ACCESSORY TRAYS are
shown in assembled position.

NOTE:

LOOSELY assemble bolt connections in this step.

STEP 15

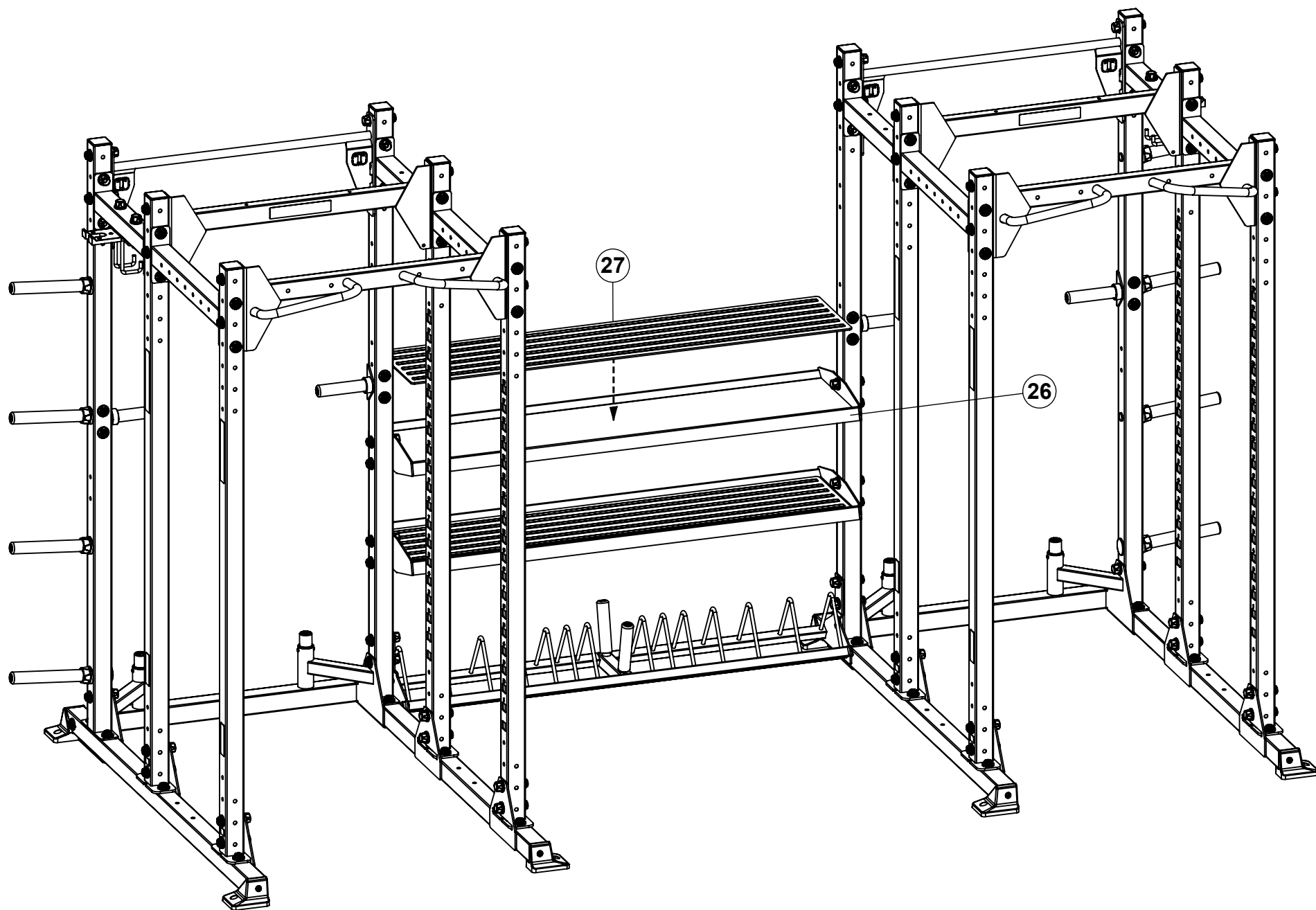

STEP 16

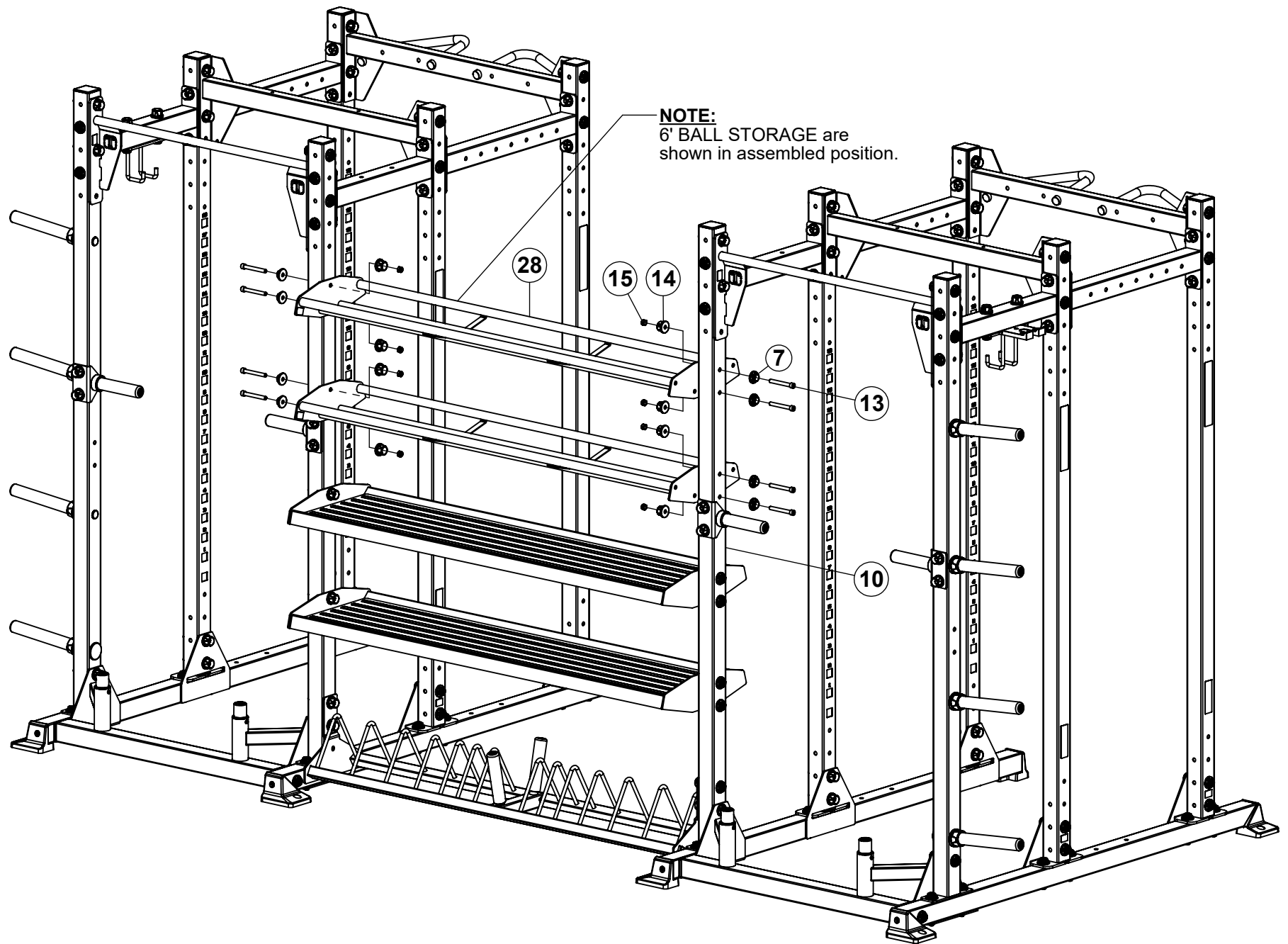

NOTE:

LOOSELY assemble bolt connections in this step.

FRAME BOLT TIGHTENING SEQUENCE

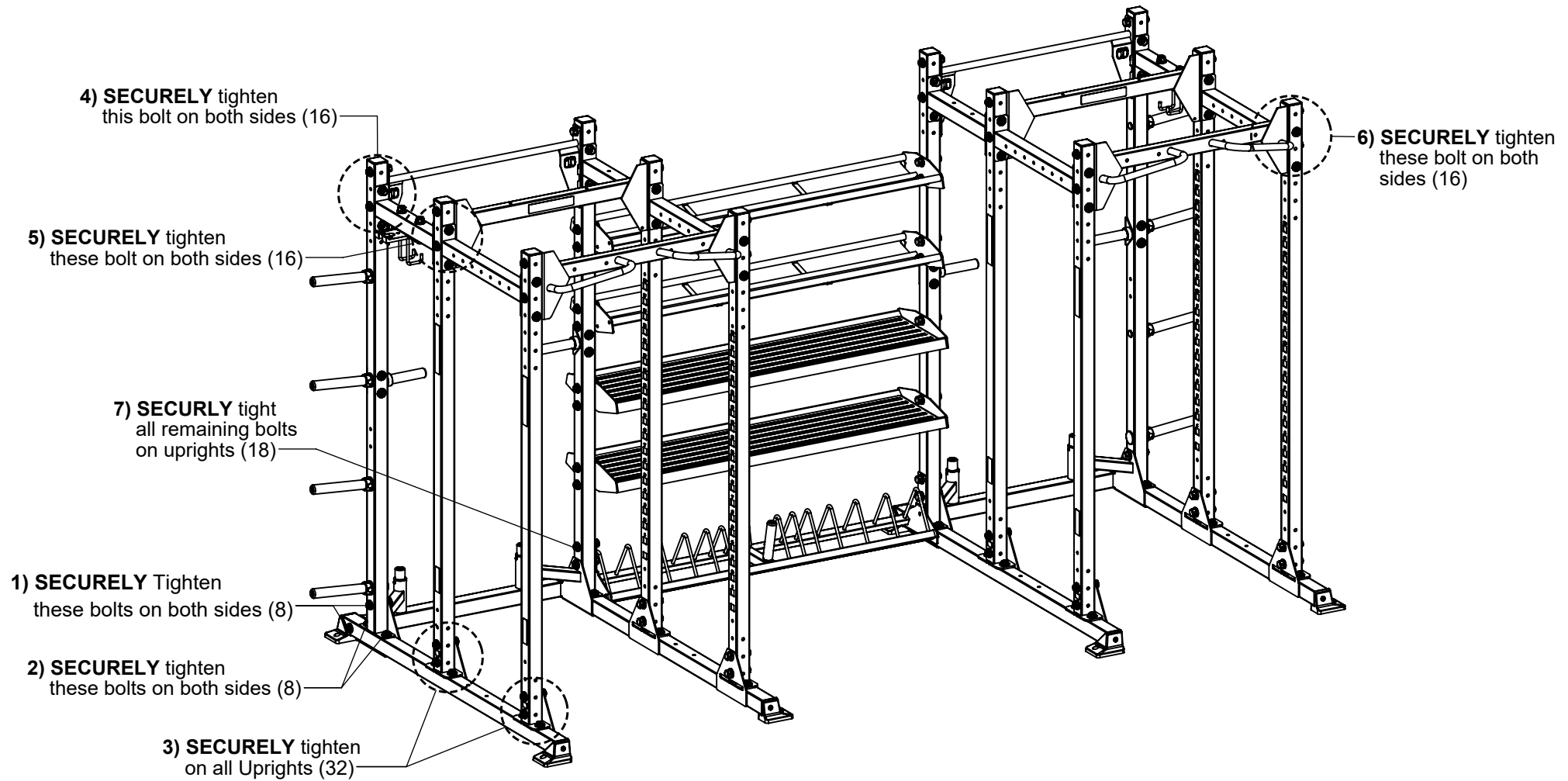

NOTE:

SECURELY tighten all bolt connections in order shown above.

ANCHORING

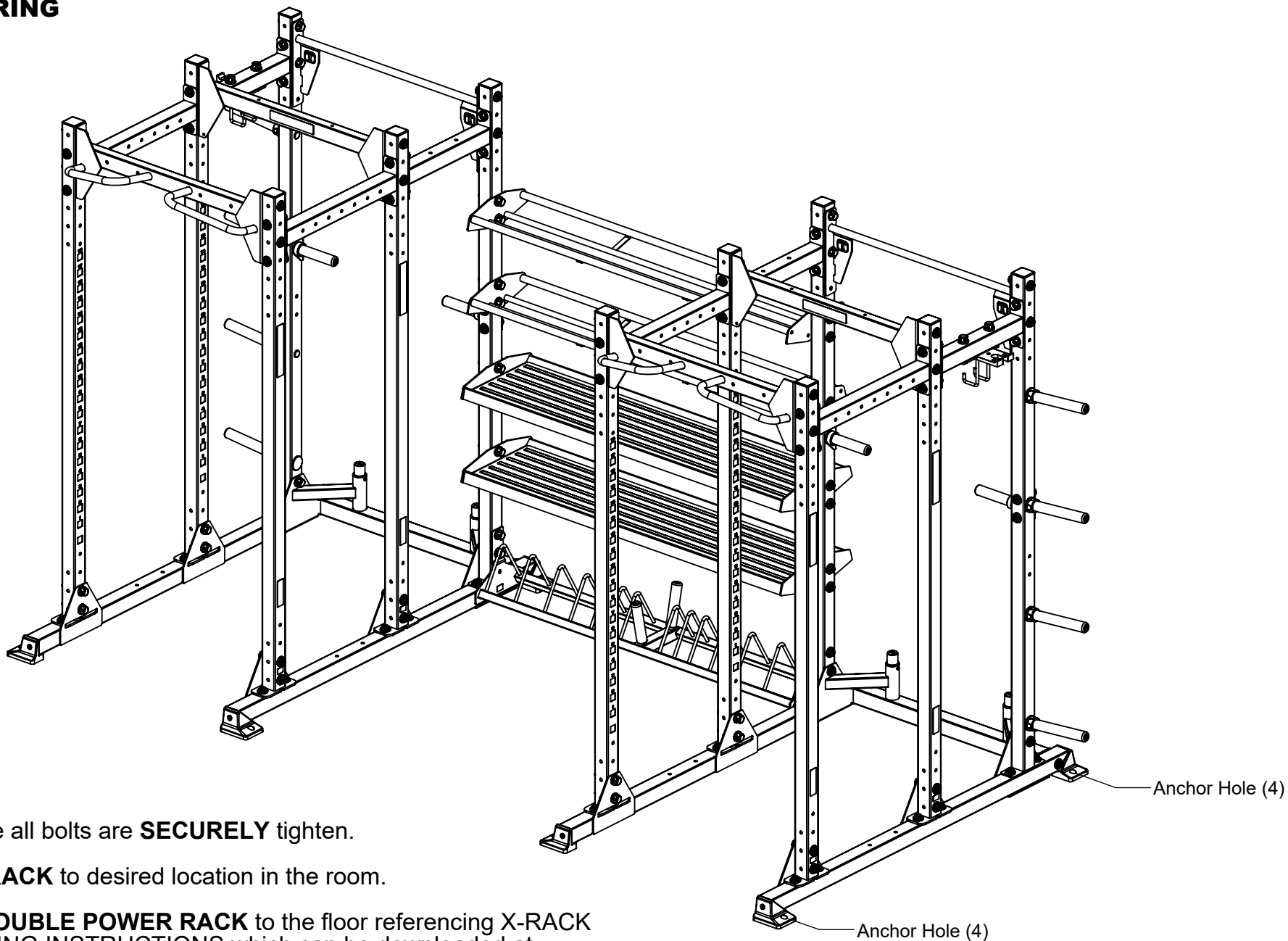

NOTES:

Make sure all bolts are **SECURELY** tighten.

Position **RACK** to desired location in the room.

Anchor **DOUBLE POWER RACK** to the floor referencing X-RACK ANCHORING INSTRUCTIONS which can be downloaded at www.torquefitness.com/pages/assembly-manuals/x-series/anchoring/x-series-floor-anchoring-inst

WARNING!

HALF RACKS ARE REQUIRED TO BE ANCHORED TO THE FLOOR TO PREVENT ROCKING OR TIPPING DURING USE.

STEP 19

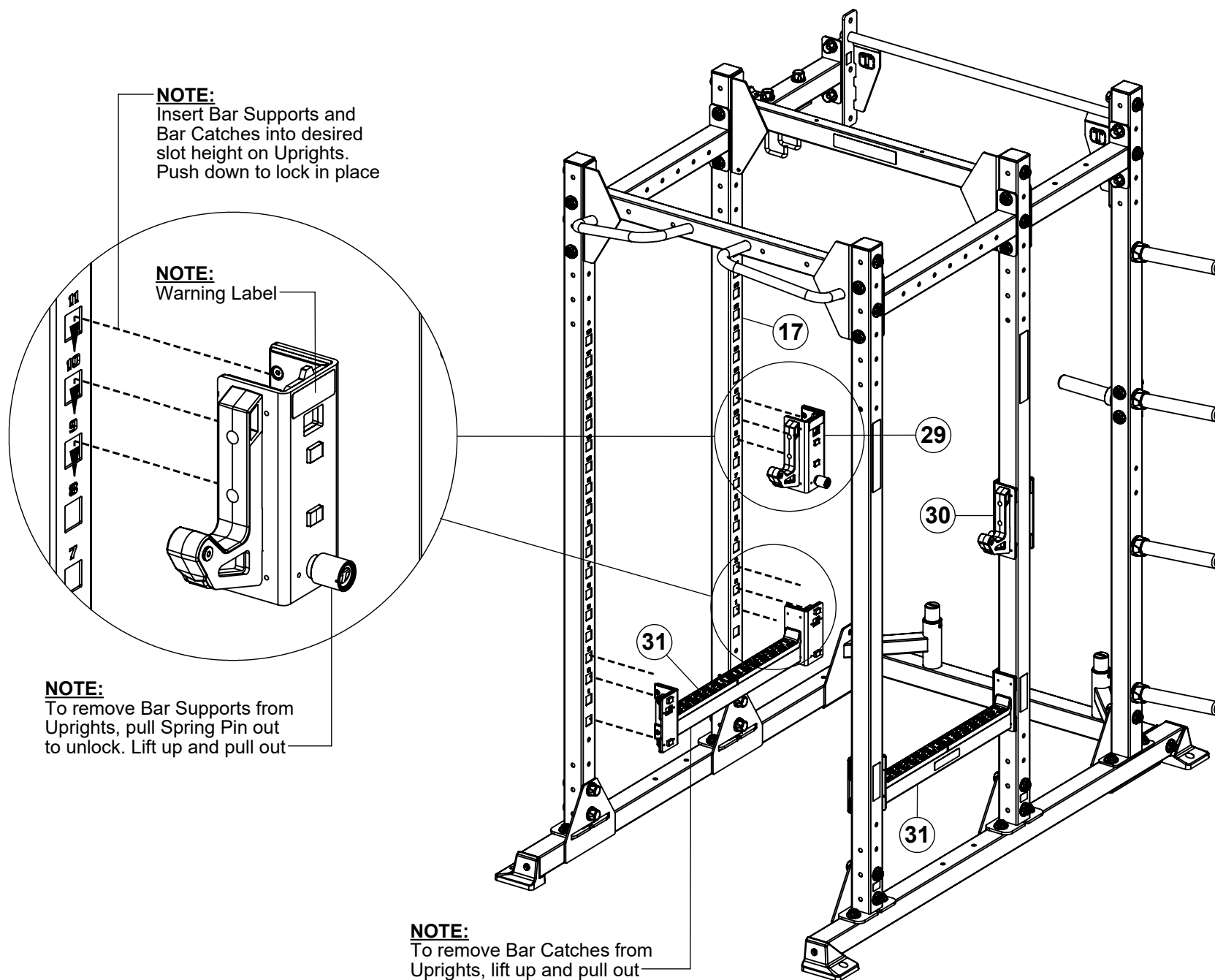

NOTE:

Some items have been hidden for assembly clarity.

WEIGHT STORAGE NUMBERING KIT

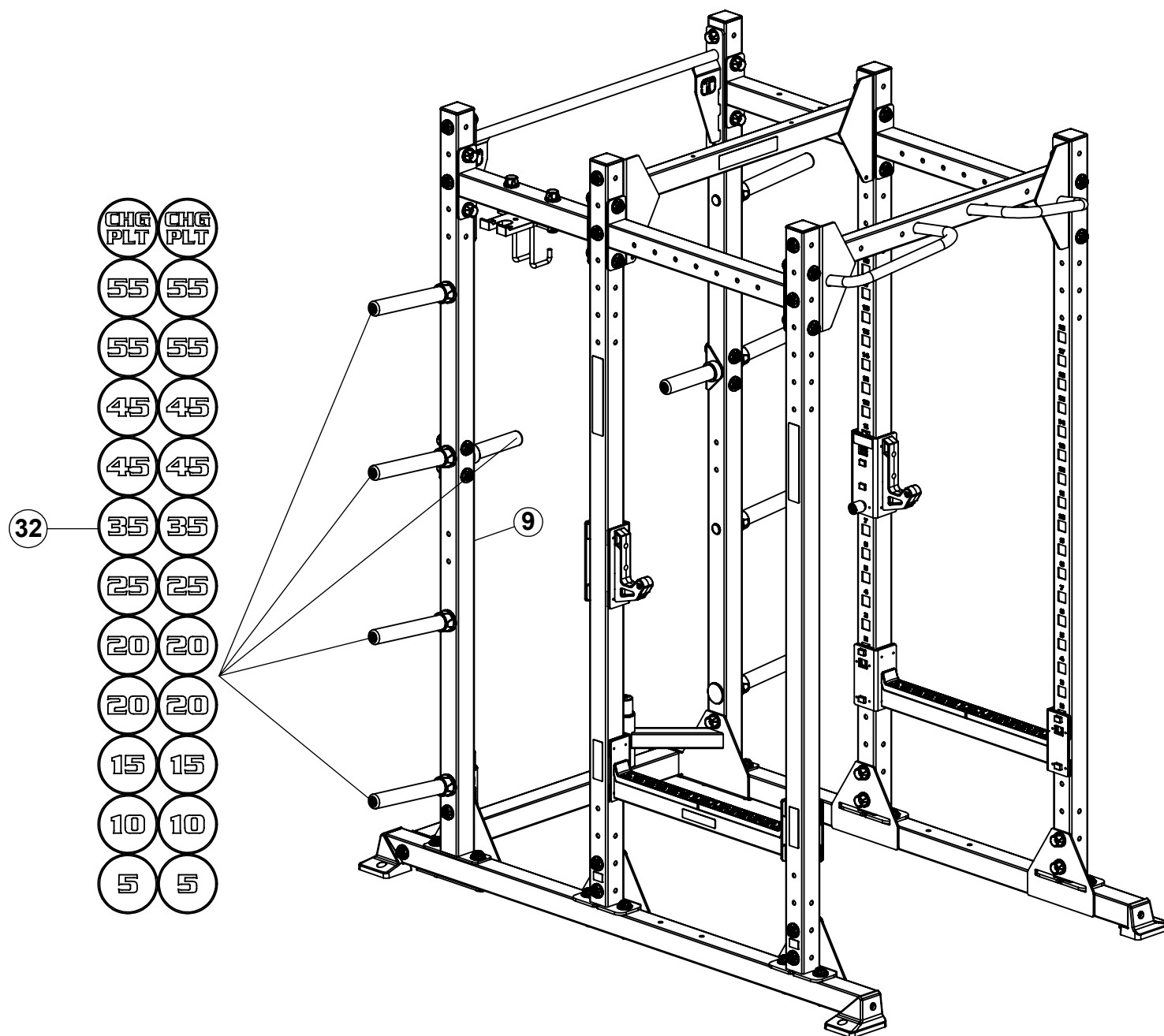

NOTE:

Using a rubber mallet, Install the desired WEIGHT STORAGE NUMBER CAP into the end of the WEIGHT HORN.

OPTIONAL LOWER BAND PEGS

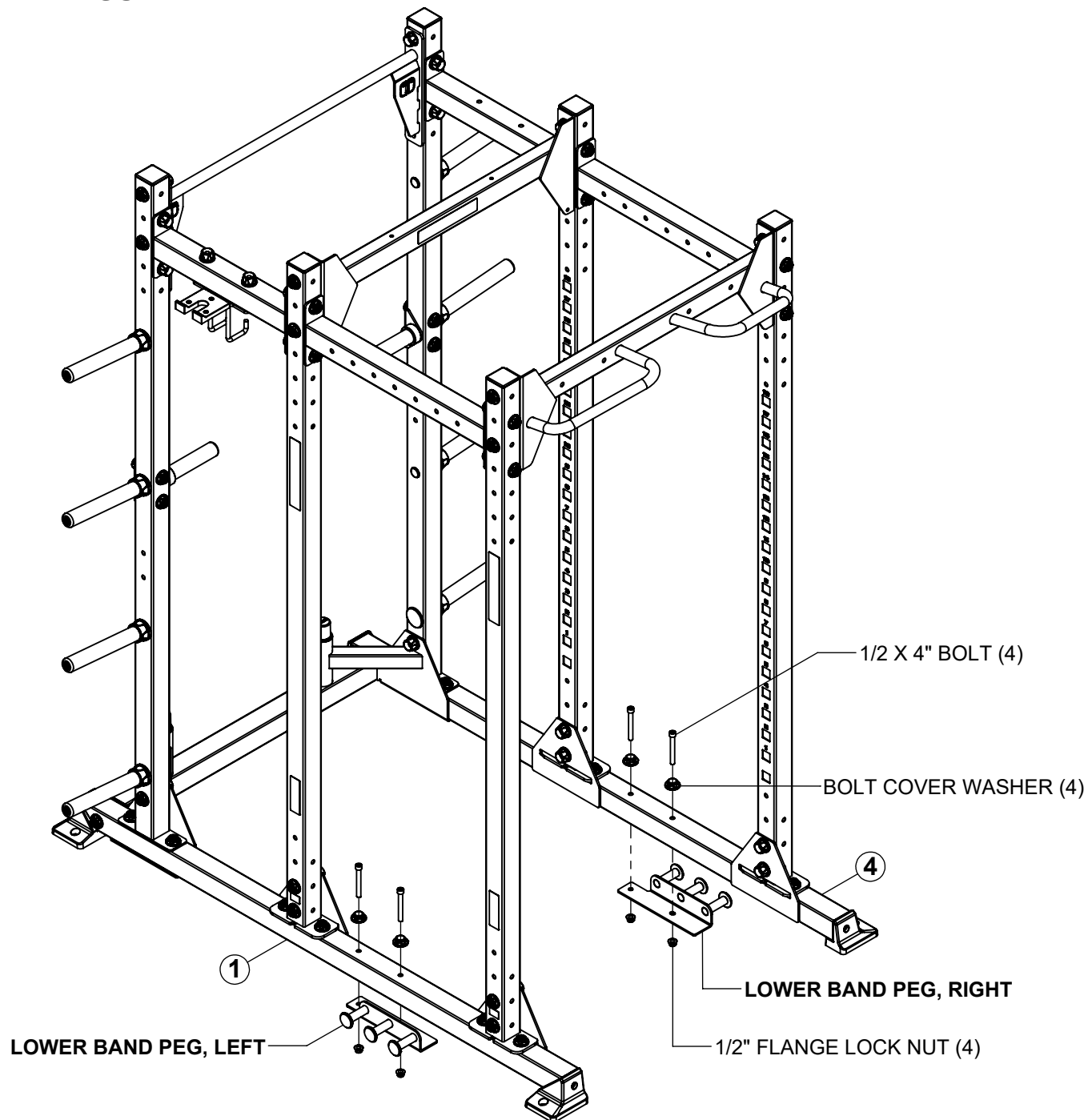

NOTES:

- Use hardware included with LOWER BAND PEGS.
- **SECURELY** tighten bolt connections in this step.

OPTIONAL SIGN BACKING BRACKET (STEP 1)

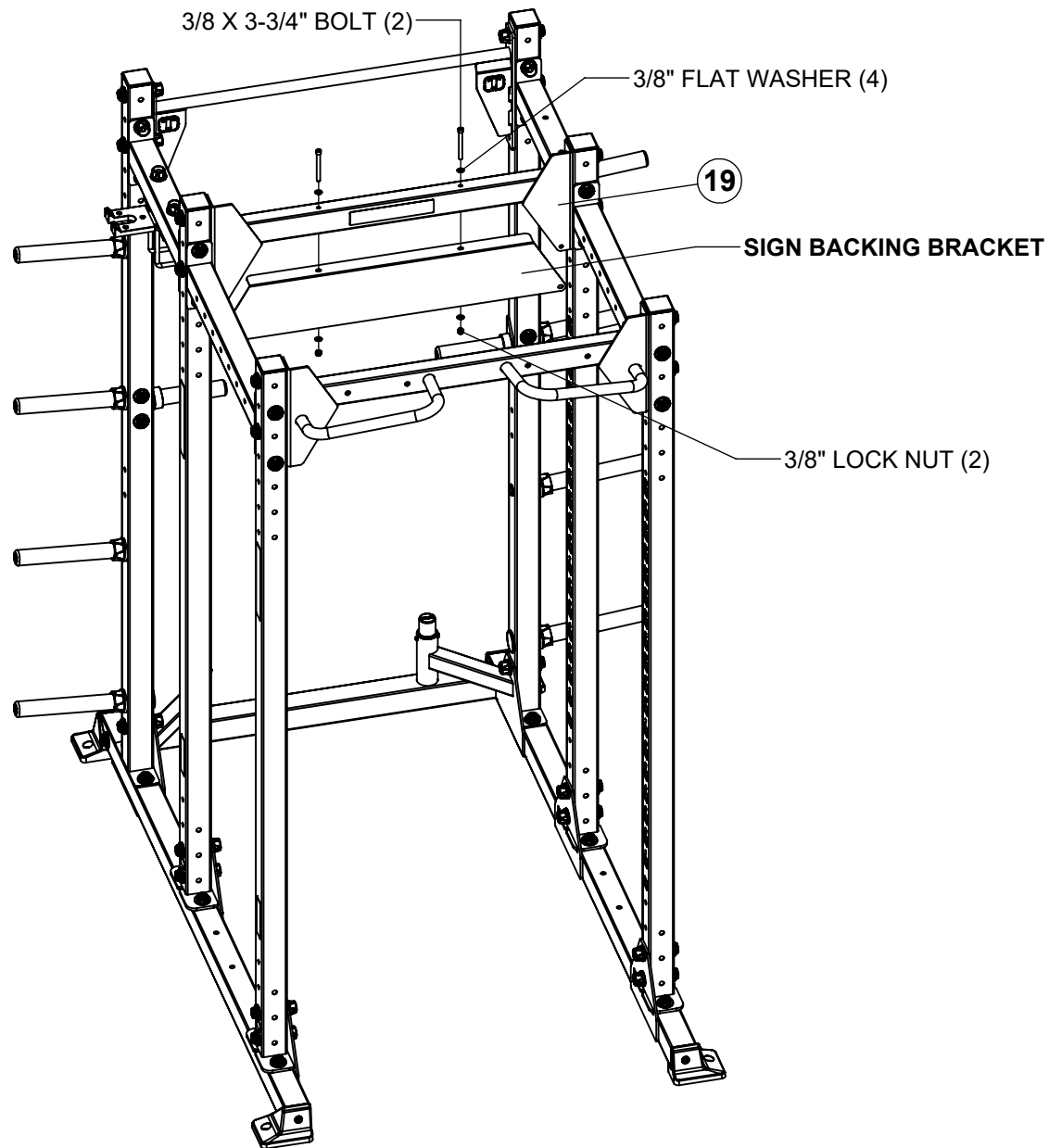

NOTES:

- Use hardware included with SIGN BACKING BRACKET.
- **LOOSELY** tighten bolt connections in this step.

OPTIONAL SIGN BACKING BRACKET (STEP 2)

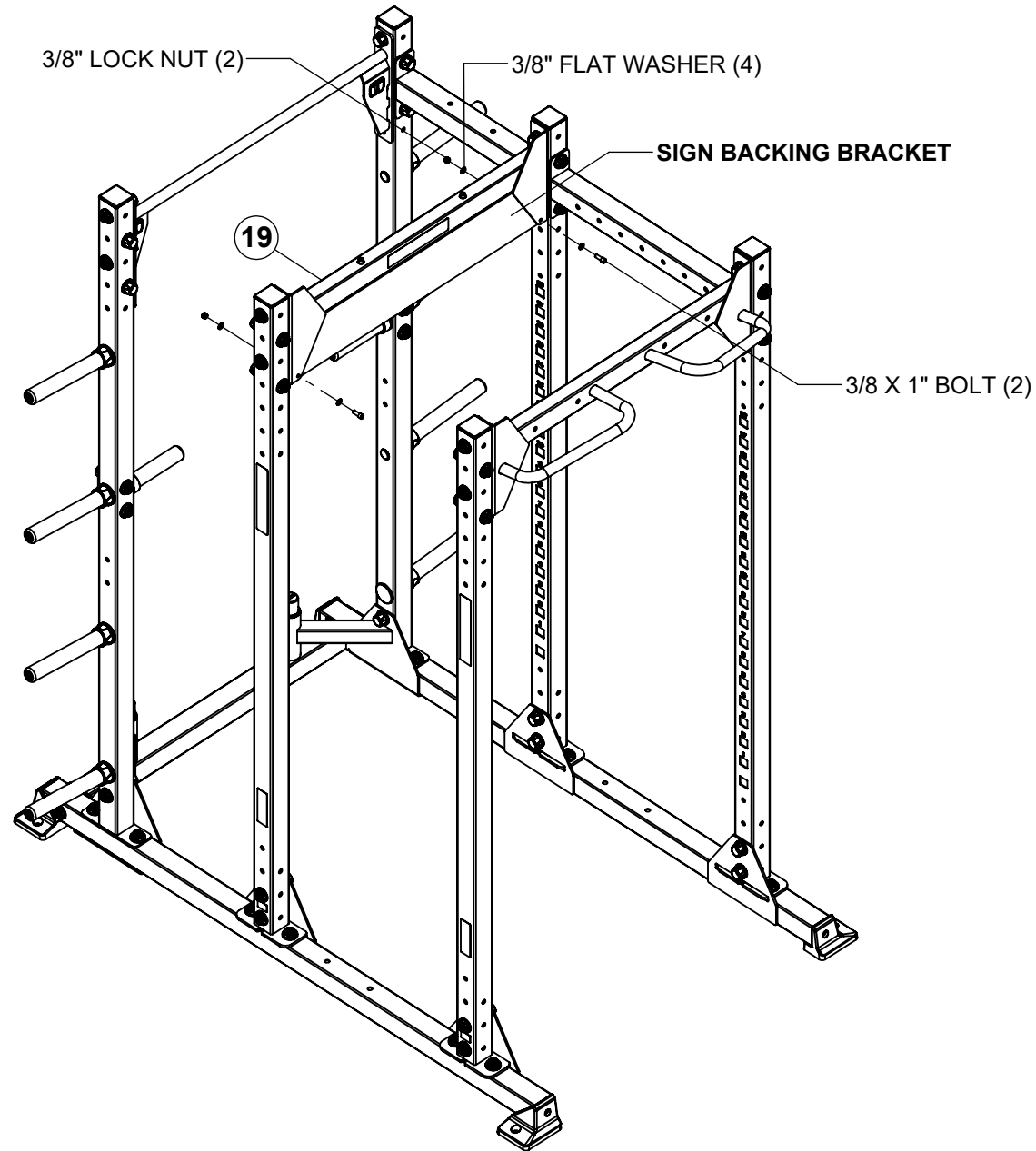

NOTES:

- Use hardware included with SIGN BACKING BRACKET.
- Once this step has been completed, **SECURELY** tighten bolt connections in this step and previous step.
- Some items have been hidden for assembly clarity.

MAINTENANCE:

NUTS/BOLTS: Tighten and/or adjust as needed.

FRAME & PADS: Wipe down and damp cloth.

For customer service contact Torque Fitness Customer service at: 763-754-7533 or www.service@torquefitness.com

