

XCREATE WALL SPACE ASSEMBLY GUIDE

VERSION: XCWS

PART #: 5843901-E

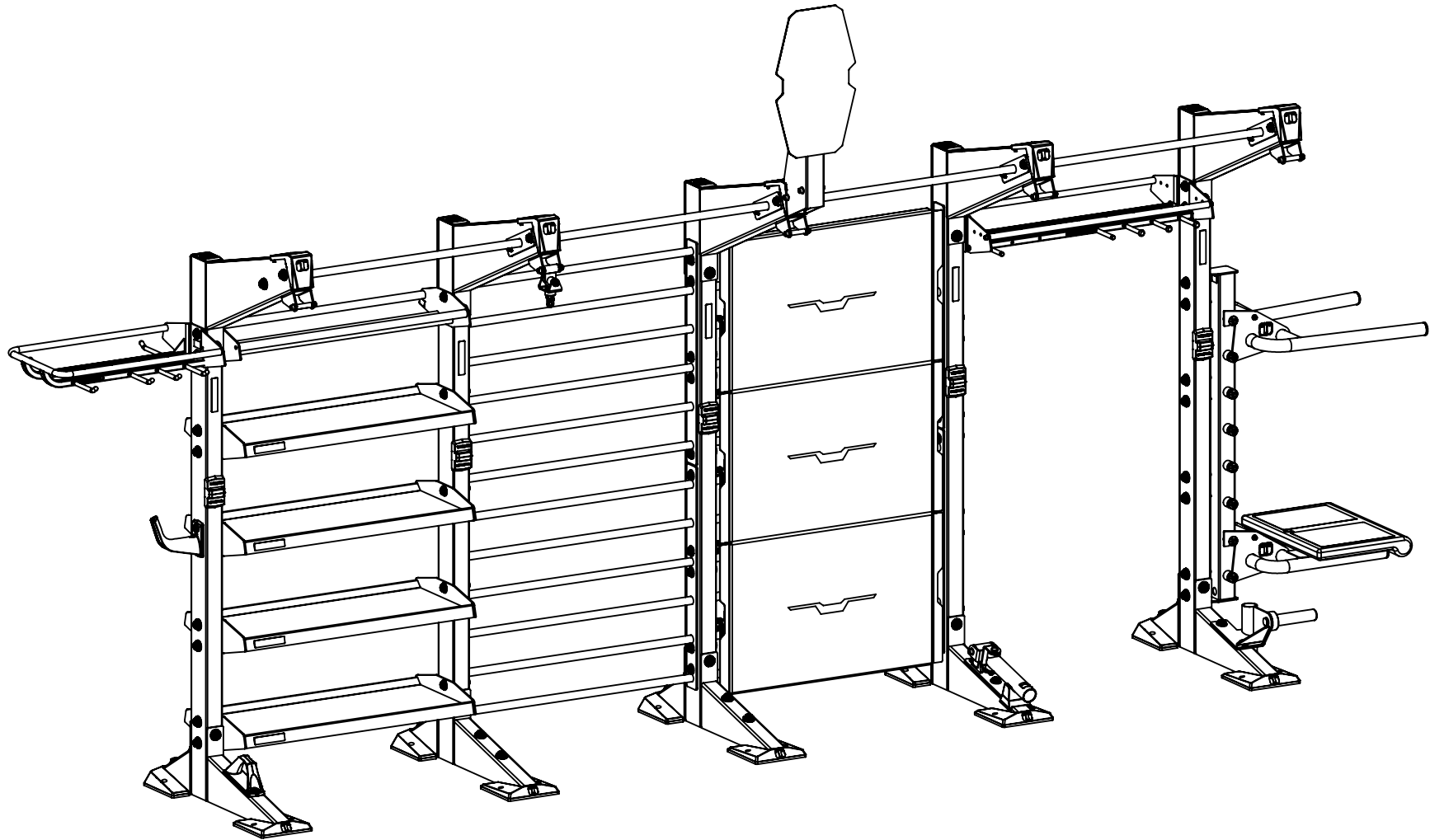

TORQUE USA

TABLE OF CONTENTS

1. OVERVIEW AND TOOLS REQUIRED: **PAGE 3**
2. UPRIGHT ASSEMBLY: **PAGES 4-5**
3. HARDWARE COVER FINISH KIT: **PAGE 6**
4. ONE MODULE ASSEMBLY: **PAGE 7**
5. CABLE MODULES AND SMITH MODULE: **PAGE 11**
6. MODULE ASSEMBLY
 - 8' UPRIGHT MODULE EXTENSION: **PAGES 12-13**
 - 4'6" ACCESSORY STORAGE MODULE: **PAGES 14-15**
 - 4'6" UNIVERSAL BALL & HANGING STORAGE MODULE: **PAGES 16-17**
 - 4' STALL BAR MODULE: **PAGES 18-19**
 - 4' BALL TARGET WALL MODULE: **PAGES 20-22**
 - 8' OLYMPIC LIFTING STATION MODULE: **PAGES 23-27**
 - 4' ACCESSORY & BUMPER BOOKSHELF STORAGE MODULE: **PAGES 28-29**
 - 4' TANK DOCKING MODULE: **PAGES 30-33**
 - 4' X 5 BARBELL STORAGE MODULE: **PAGES 34-37**
 - 4' X 10 BARBELL STORAGE MODULE: **PAGES 38-41**
 - 4' 2 SIDED X 10 BARBELL STORAGE MODULE: **PAGES 42-45**
 - 4' 2 SIDED X 20 BARBELL STORAGE MODULE: **PAGES 46-49**
 - 4' MONITOR MOUNT & STORAGE MODULE: **PAGES 50-53**
 - 4' CUSTOM SIGN AND HANGING STORAGE: **PAGES 54-55**
 - 2.5' BALL AND HANGING STORAGE MODULE: **PAGES 56-57**
 - 6' RECTANGLE CROSS MODULE: **PAGES 58-59**
 - 4' HEAVY BAG MODULE: **PAGES 60-61**
 - ACCESSORY PEGS & MAT STORAGE PINS: **PAGE 62**
 - ACCESSORY TRAY LABELS: **PAGES 63**
7. ATTACHMENT ASSEMBLY
 - BALL & HANGING STORAGE EXTENSION: **PAGE 68**
 - BATTLE ROPE ANCHOR: **PAGE 69**
 - HANGING STORAGE HOOK: **PAGE 70**
 - DOUBLE PLAY: **PAGE 71**
 - HORIZONTAL MOUNT GROUND ROTATIONAL TRAINER: **PAGE 72**
 - 3-DIMENSIONAL SWIVEL: **PAGES 73-74**
 - BALL TARGET: **PAGES 75-77**
 - RESISTANCE BAND ANCHOR: **PAGE 78**
 - VERTICAL DUMBBELL RACK: **PAGE 79**
 - 4' MULTI GRIP CROSS: **PAGE 80**
 - 4' SINGLE SIDE HORIZONTAL WEIGHT STORAGE: **PAGE 81**
 - TOP BOOM EXTENSION: **PAGES 82-85**
 - ATTACHMENT ANCHOR: **PAGE 86**
 - DIP ATTACHMENT: **PAGE 87**
6. ATTACHMENT ASSEMBLY CONTINUED
 - PLYO STEP: **PAGE 88**
 - ATTACHMENT EXTENSION: **PAGES 89-90**
 - ATTACHMENT EXTENSION & 3 DIMENSIONAL SWIVEL W/MOUNT: **PAGE 91**
 - RELENTLESS ROPE TRAINER (UPRIGHT): **PAGES 92-93**
 - BOOM MOUNT: **PAGES 94-95**
 - RELENTLESS ROPE TRAINER & BOOM MOUNT: **PAGES 96-97**
 - RELENTLESS RIPPER & BOOM MOUNT: **PAGES 96-97**
 - XCREATE SIDE ATTACHMENT MOUNT: **PAGE 98**
 - 6RX ATTACHMENTS: **PAGES 99-100**
 - 4' WALL ANCHOR BRACKET: **PAGES 101-105**
 - 4' COUNTERWEIGHT SUPPORT: **PAGES 106-108**
 - 6' COUNTERWEIGHT SUPPORT: **PAGES 109-113**
 - OUTRIGGER: **PAGES 114-115**
 - BOSU STORAGE ATTACHMENT: **PAGE 116**
 - FOAM ROLLER STORAGE: **PAGES 117-118**
 - STALL BAR DIP ATTACHMENT: **PAGE 119**
 - BAR CATCH STORAGE ATTACHMENT: **PAGE 120-121**
 - SUSPENSION CLIP: **PAGE 122**
 - CHANGE PLATE WEIGHT HORN: **PAGE 123**
 - XCREATE-GRT / XCREATE-TP: **PAGE 124**
 - XCREATE-GRTPS / XCREATE-TP: **PAGE 125**
 - XCREATE-GRTBS / XCREATE-TP: **PAGE 126**
 - XCREATE-4OSB: **PAGE 127**
7. ANCHORING: **PAGE 128**
8. URETHANE BOOTS: **PAGE 129**

WARNING!

ALL X-CREATE ARE REQUIRED TO BE ANCHORED TO THE FLOOR TO PREVENT ROCKING OR TIPPING DURING USE.

OVERVIEW AND TOOLS REQUIRED

X-CREATE Wall Space Systems can be customized in countless ways. This manual provides instructions for assembling base units, module options and attachment options.

Not all modules or attachments are detailed in this assembly guide. For further instruction on these, reference the individual guide for the module being installed.

If you worked with Torque X-Team Design during the purchasing process, please request a Bill of Material Drawing to reference your exact set-up. For assistance, contact www.sales@torquefitness.com or call (763) 754-7533

NOTE:

When assembling any X-CREATE System that is longer than one module wide, the hardware will be shared between two side by side modules and pull-up bars. It is recommended to keep all bolt connections loose until the base system and all of the module stations have been assembled. Securely tighten all frame connections at this time, and then proceed to the attachment options. Attachment options can be securely tightened as they are assembled.

For the purpose of illustration, the 8U is shown in this assembly guide. The 7U can be assembled the exact same way where specified in the notes.

TOOLS FOR ASSEMBLY:

- 3/8" ALLEN WRENCH
- 5/16" ALLEN WRENCH
- 3/16" ALLEN WRENCH
- 3/4" WRENCH OR SOCKET
- 9/16" WRENCH OR SOCKET
- 1/2" WRENCH OR SOCKET
- RUBBER MALLETT

WARNING!

ALL X-CREATE ARE REQUIRED TO BE ANCHORED TO THE FLOOR TO PREVENT ROCKING OR TIPPING DURING USE.

XCREATE-U-8SS ASSEMBLY

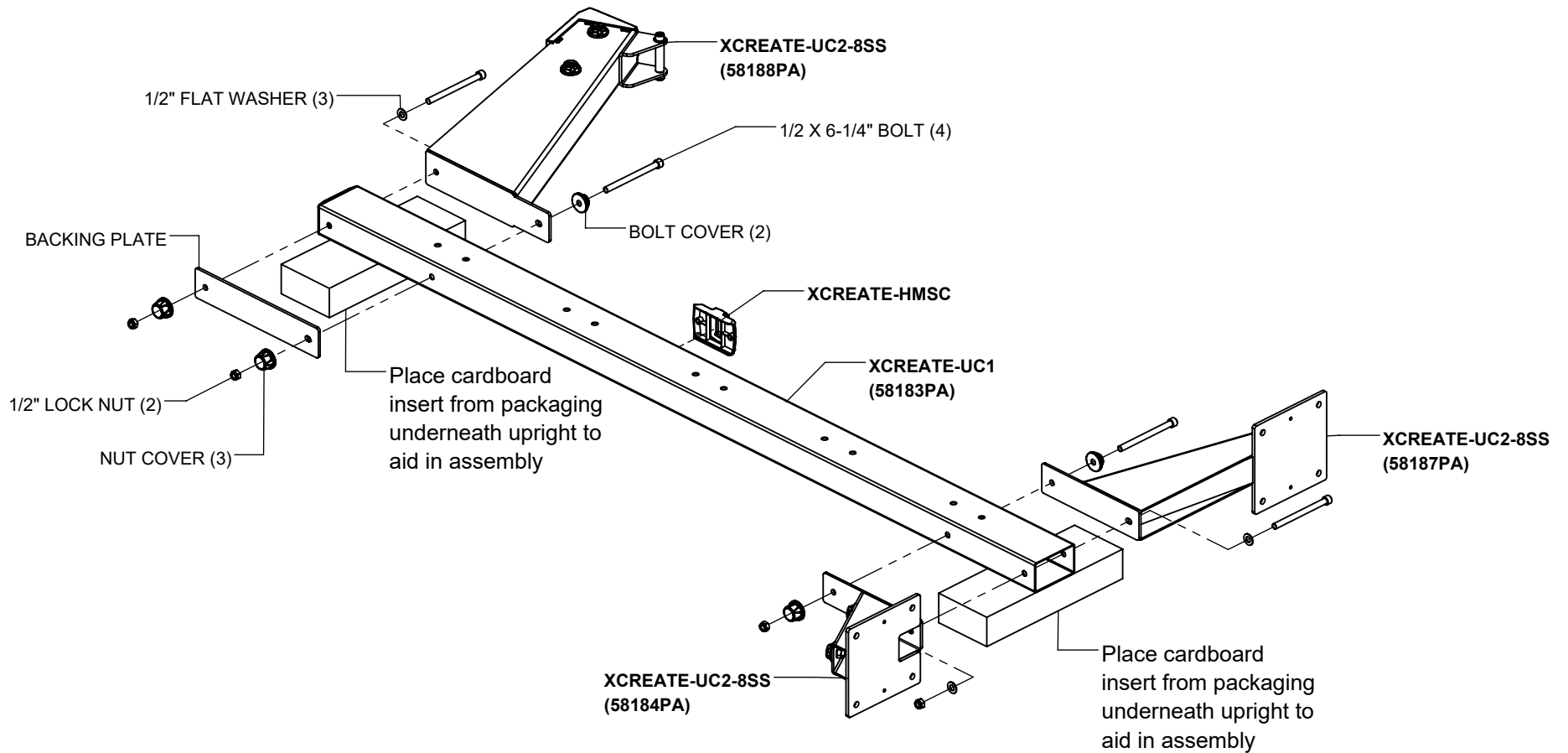

NOTES:

This step requires two people to assemble. Please get help.

Assemble the UPRIGHT on the floor.

Assemble all parts together first, then **SECURELY** tighten all bolt connections.

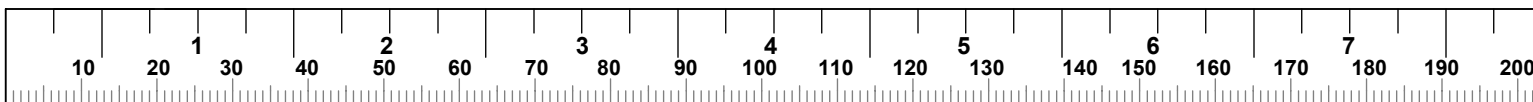

XCREATE-U-7SS ASSEMBLY

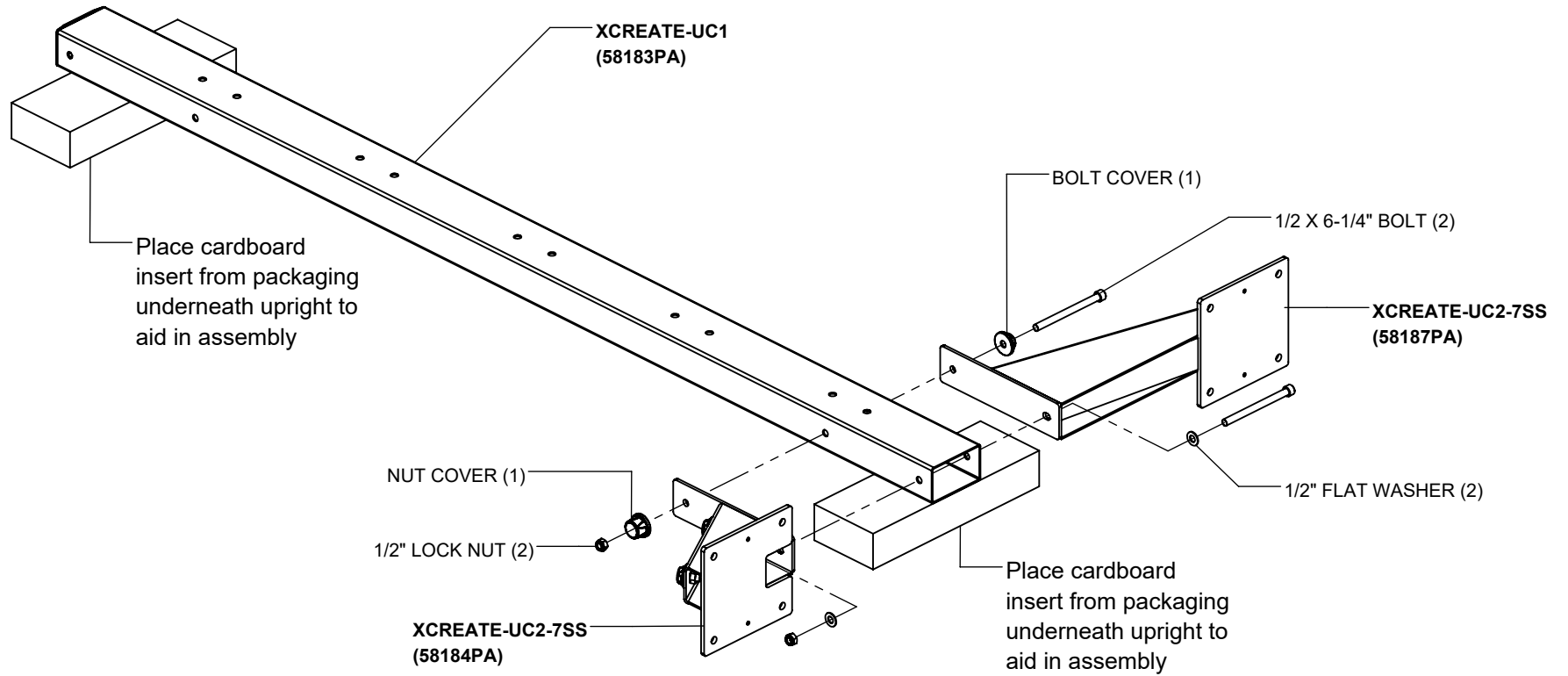

NOTES:

This step requires two people to assemble. Please get help.

Assemble the UPRIGHT on the floor.

Assemble all parts together first, then **SECURELY** tighten all bolt connections.

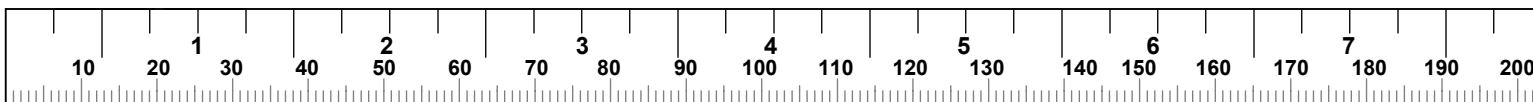

HARDWARE COVERS

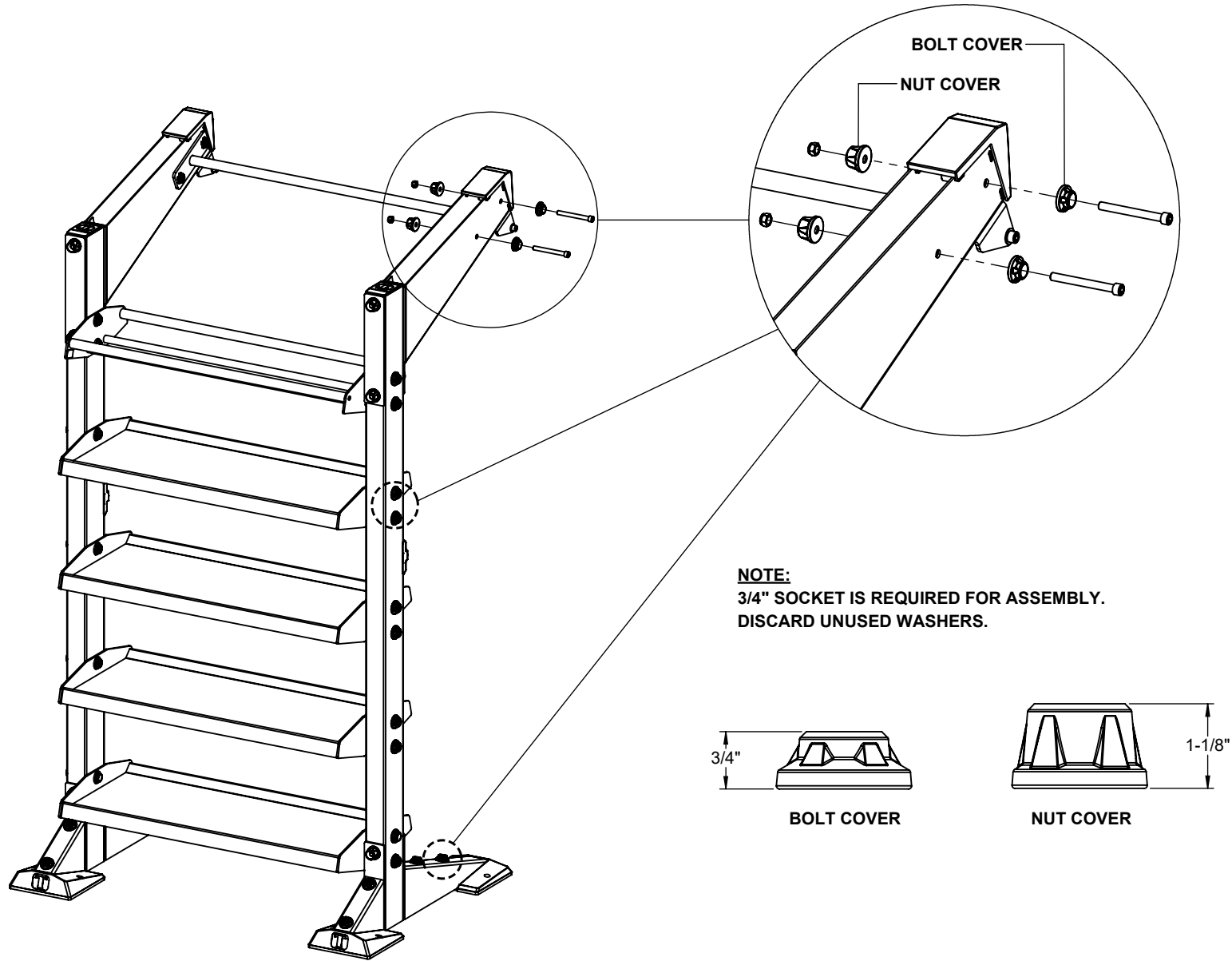

IMPORTANT NOTICE ABOUT HARDWARE COVERS:

The bolt and nut covers **may not fit all assembly applications.**
Use the flat washers included when shown in this guide.

ONE MODULE ASSEMBLY

NOTE:

REMOVE END CAPS PRIOR TO ASSEMBLY.
RE-ATTACH END CAPS AFTER ASSEMBLY (2)

NOTE:

MAKE SURE TO USE PRE-INSTALLED SPACERS (4)

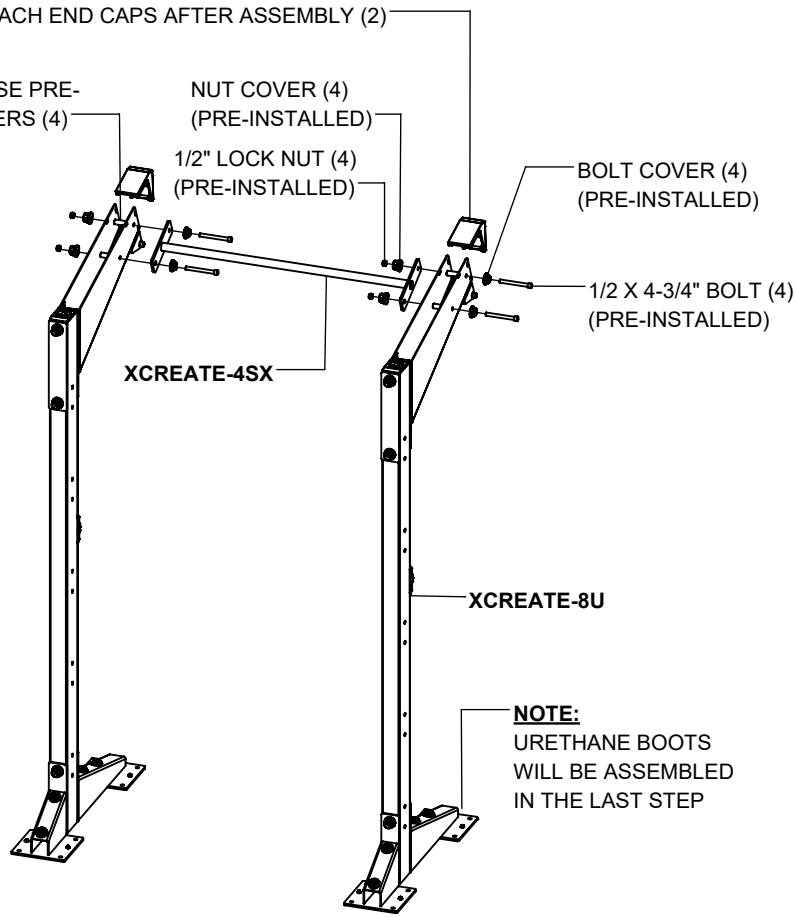

NOTE:
URETHANE BOOTS
WILL BE ASSEMBLED
IN THE LAST STEP

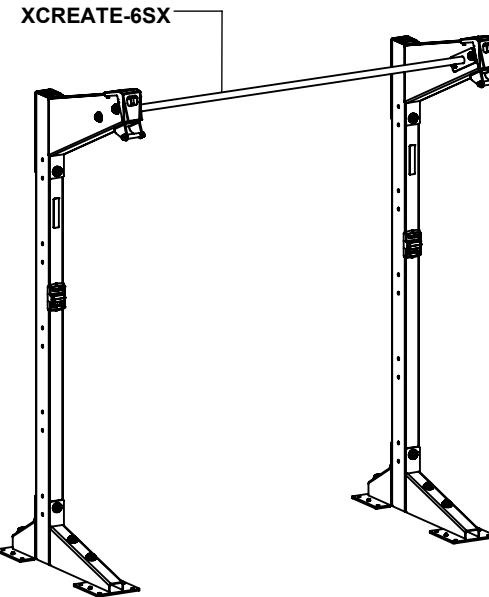
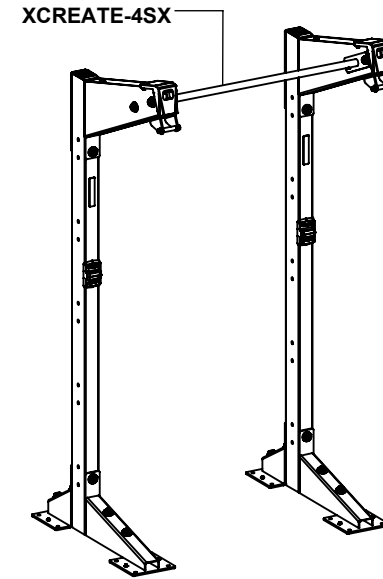

NOTES:

For the purpose of illustration the XCREATE-4SX is shown.
The XCREATE-6SX is assembled the same way.

LOOSELY assemble bolt connections in this step.

If more than one module will be assemble, refer to **PAGE 7**.

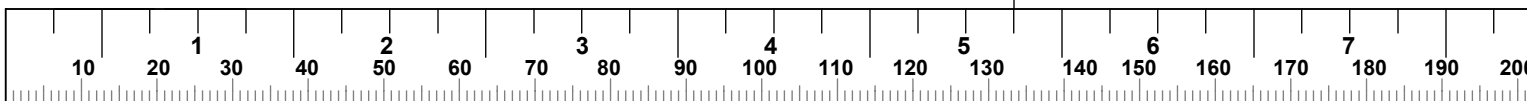

MODULES

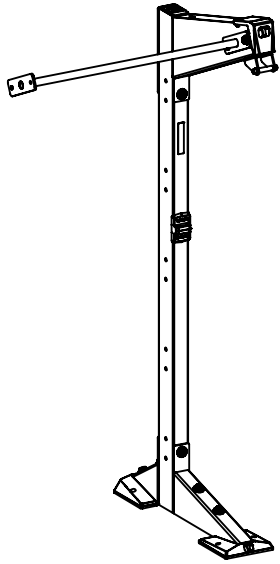

**8' UPRIGHT
MODULE EXTENSION**

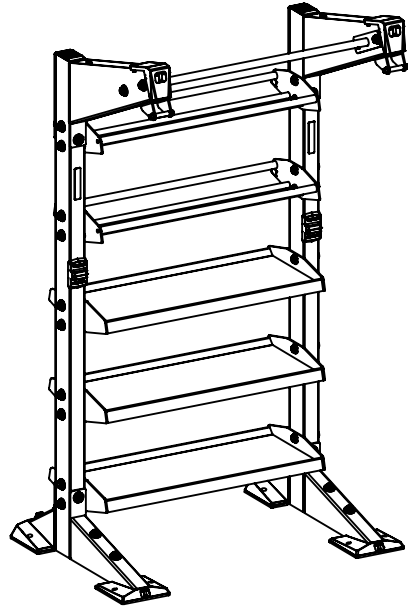

4' / 6' STORAGE MODULE

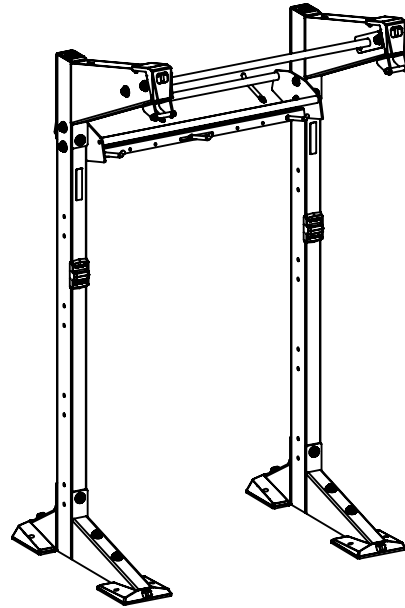

**4' / 6' BALL & HANGING
STORAGE MODULE**

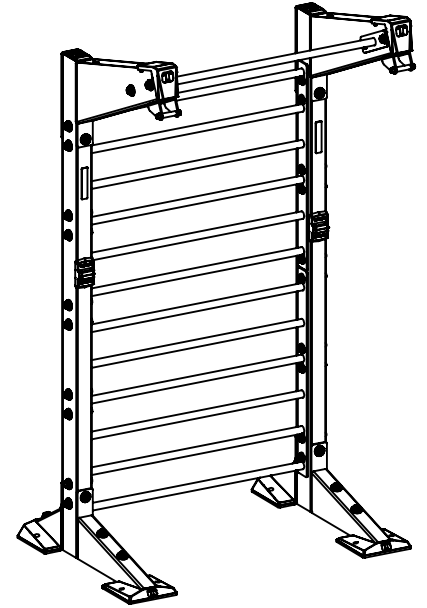

4' STALL BAR MODULE

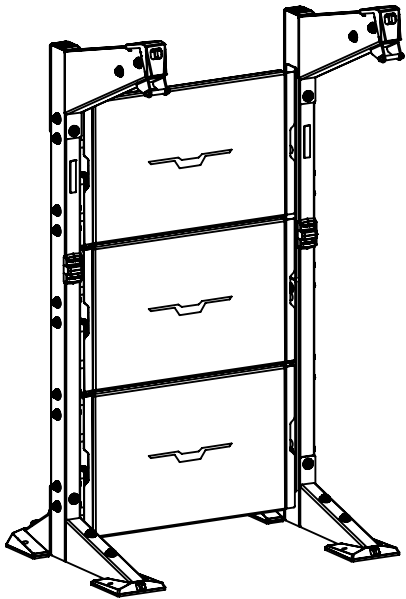

**4' BALL TARGET WALL PAD
MODULE**

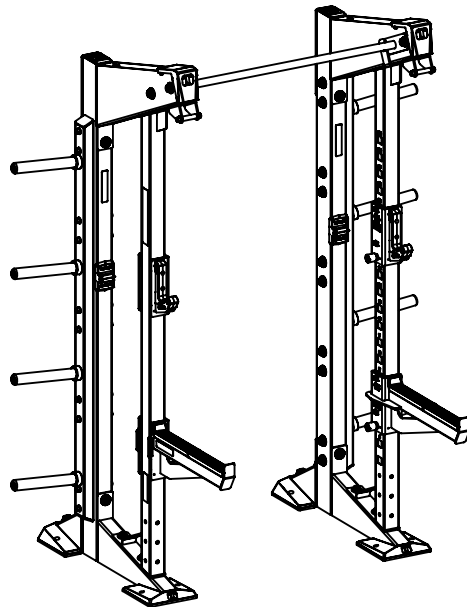

**8' OLYMPIC LIFTING
STATION MODULE**

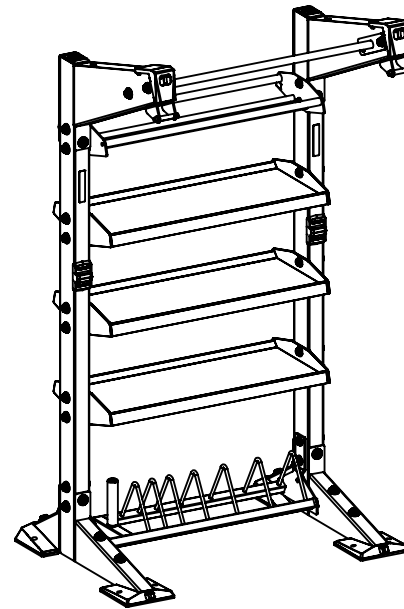

**4' / 6' ACCESSORY & BUMPER
STORAGE MODULE**

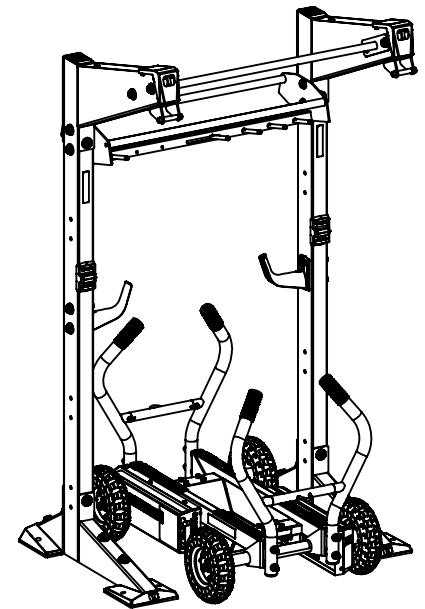

4' TANK DOCKING MODULE

MODULES

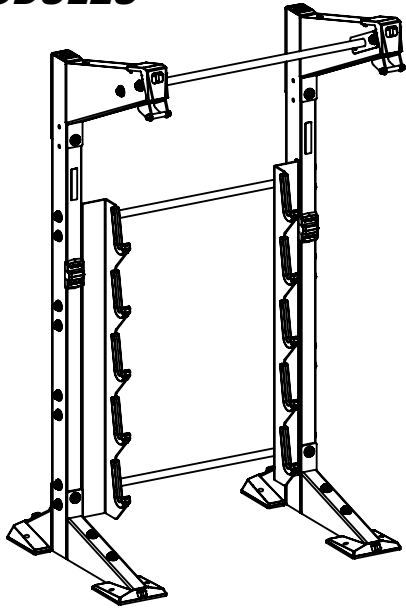

**4' X 5 BARBELL STORAGE
MODULE**

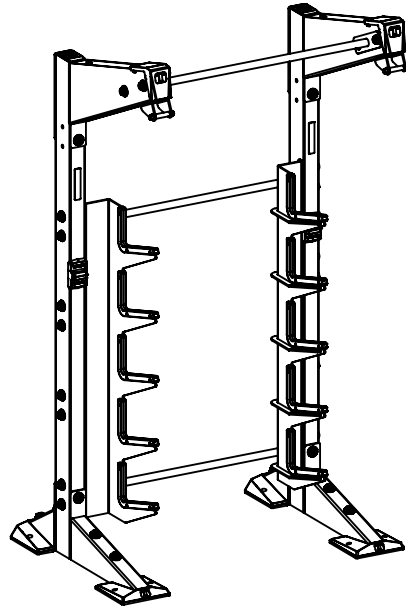

**4' X 10 BARBELL STORAGE
MODULE**

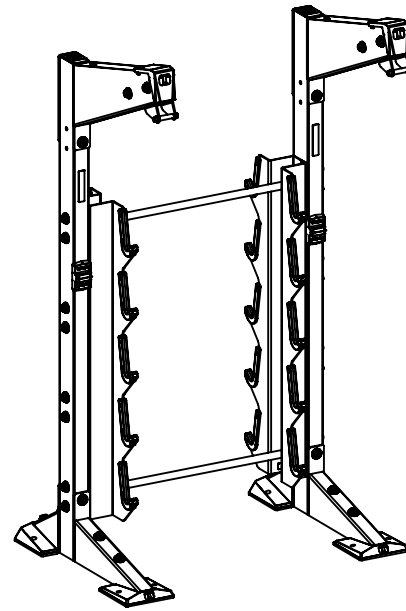

**4' X 2 SIDED X 10 BARBELL
STORAGE MODULE**

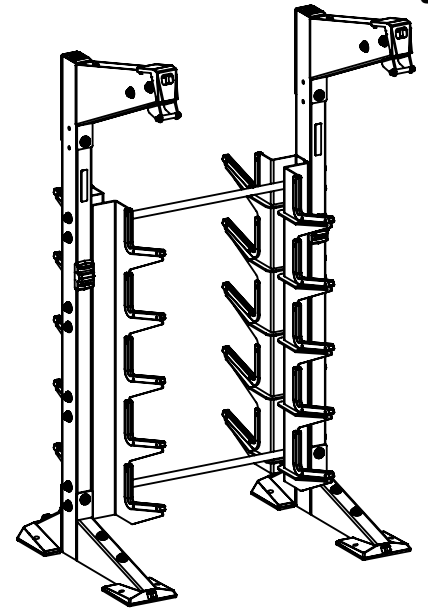

**4' X 2 SIDED X 20 BARBELL
STORAGE MODULE**

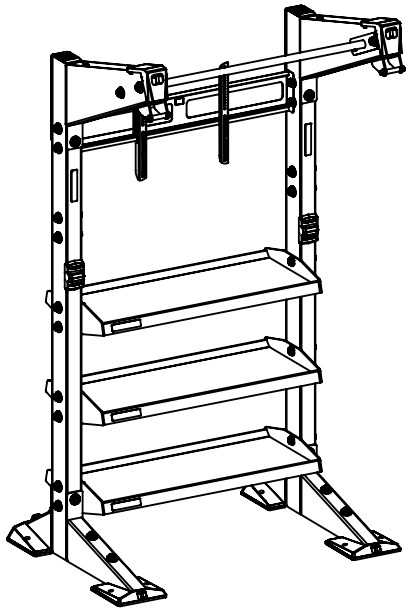

**4' MONITOR MOUNT
STORAGE MODULE**

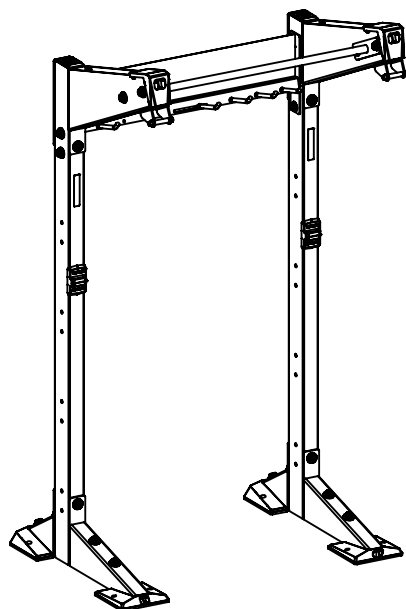

**4' CUSTOM SIGN AND HANGING
STORAGE MODULE**

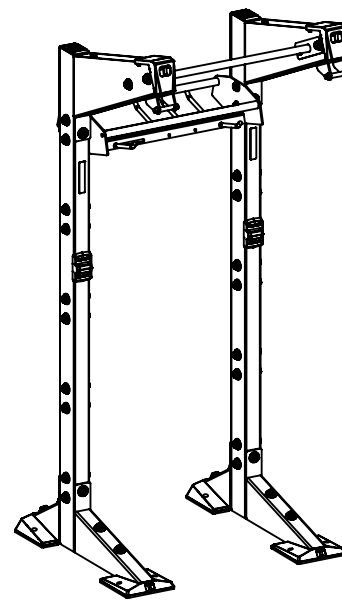

**2.5' BALL AND HANGING STORAGE
MODULE**

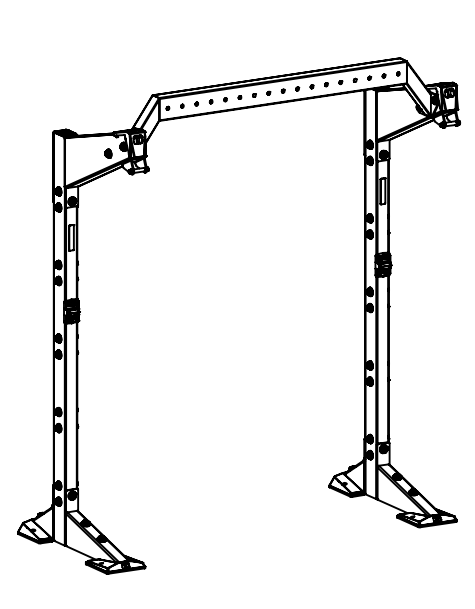

6' RECTANGULAR CROSS MODULE

MODULES

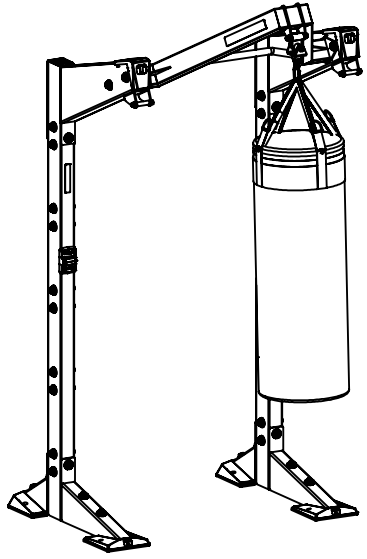

**4' HEAVY BAG
MODULE**

NOT COVERED IN THIS GUIDE

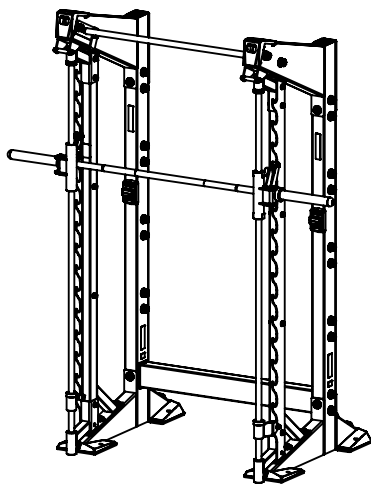

SMITH MODULE

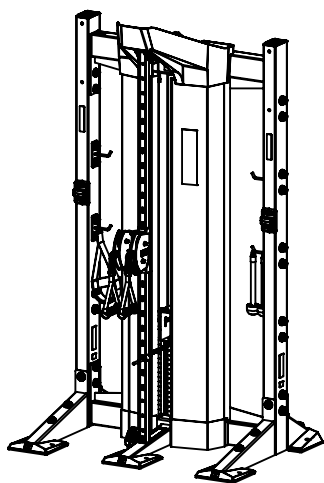

**CABLE COMPONENT
MODULE**

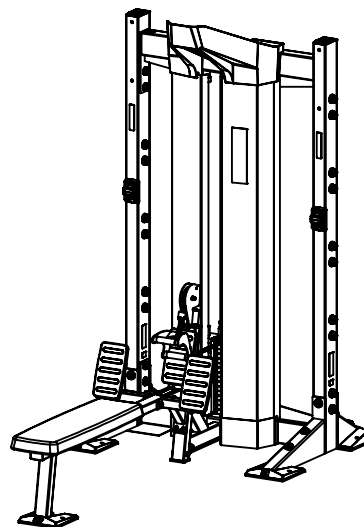

**SEATED ROW
MODULE**

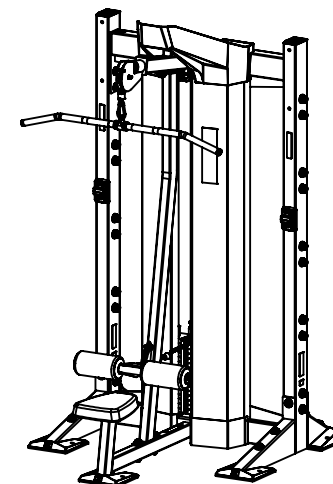

**LAT PULL DOWN
MODULE**

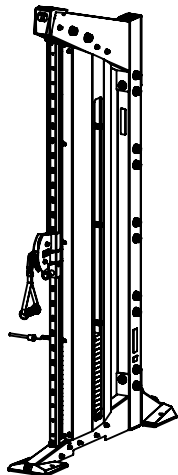

UPRIGHT CABLE COLUMN

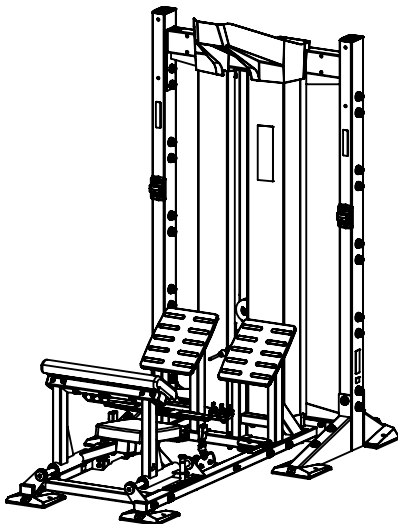

HIP THRUST MODULE

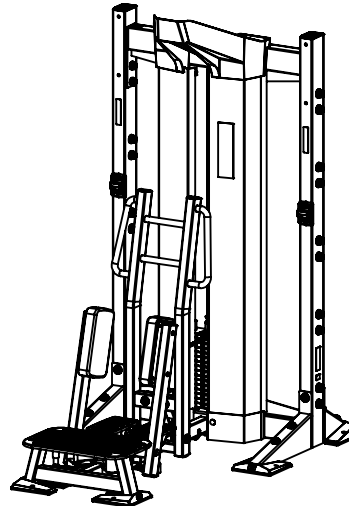

**STANDING ABDUCTOR
MODULE**

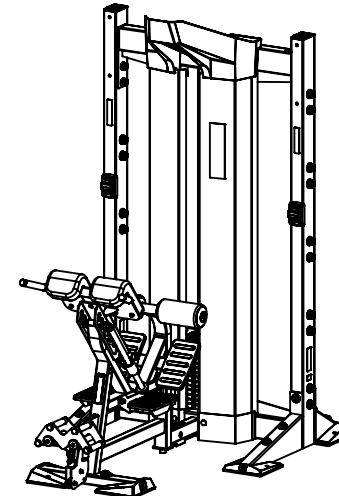

**BACK EXTENSION
MODULE**

NOTES:

For the above modules and attachments, visit [Torquefitness.com](https://commercial.torquefitness.com) for the specific assembly manual for the product being assembled. The manuals can be downloaded at <https://commercial.torquefitness.com/pages/assembly-manuals>

8' UPRIGHT MODULE EXTENSION

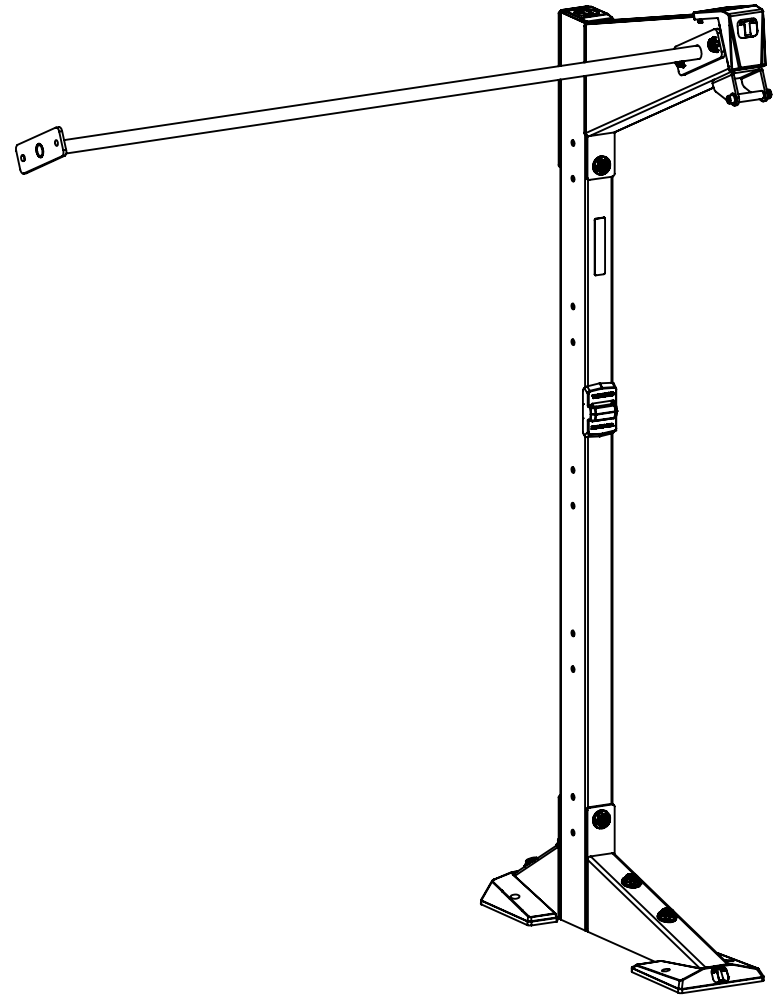
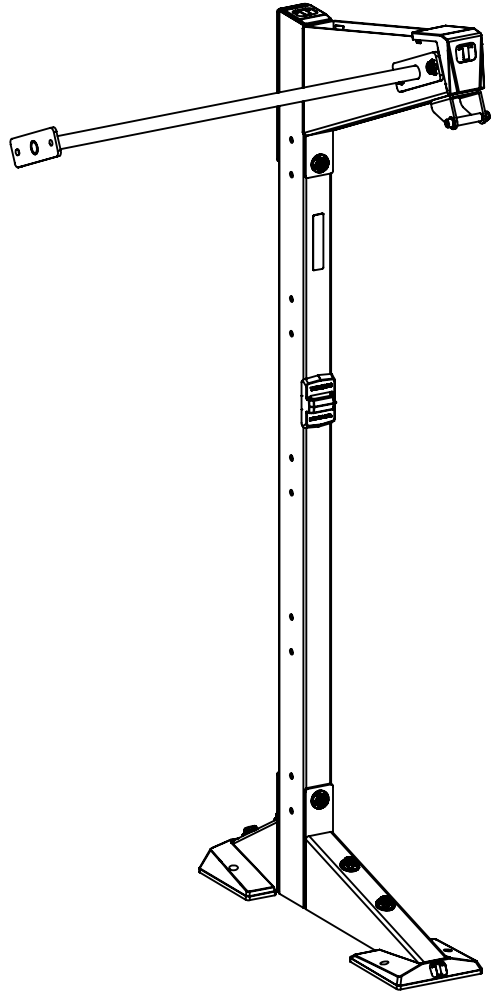

8' UPRIGHT MODULE EXTENSION

NOTE:
MAKE SURE TO USE PRE-INSTALLED SPACERS (4)

NOTE:
REMOVE END CAP PRIOR TO ASSEMBLY.
RE-ATTACH END CAP AFTER ASSEMBLY (2)

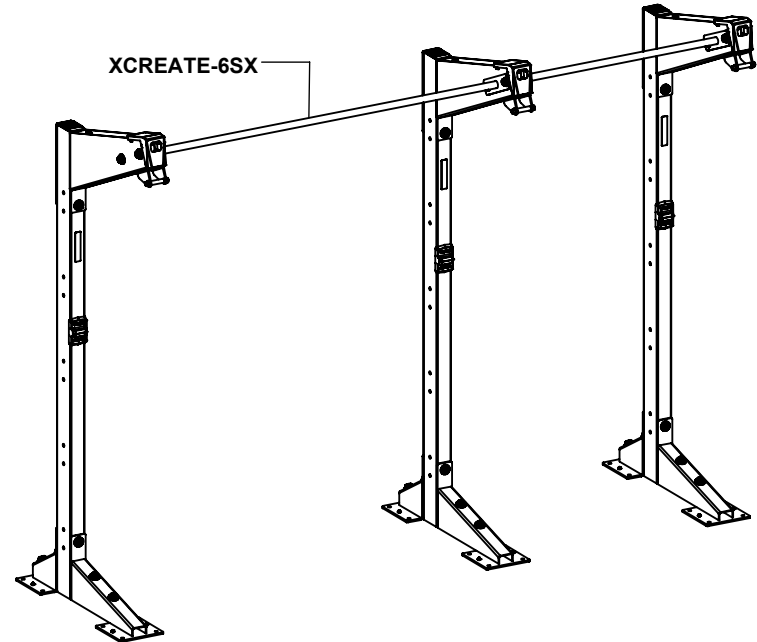
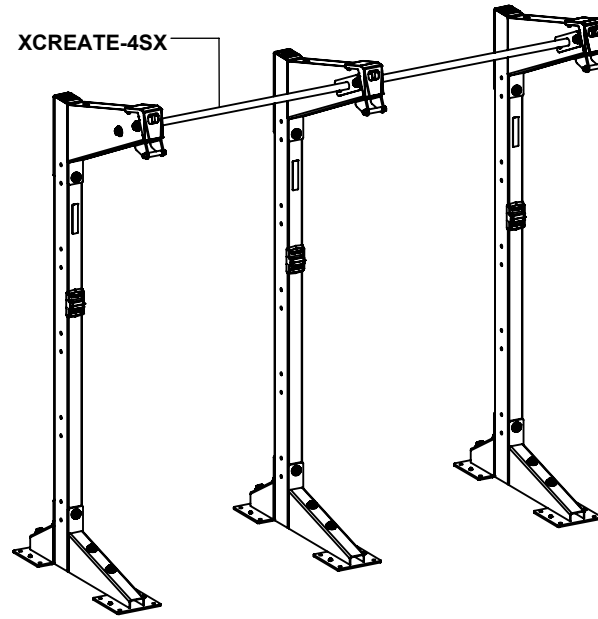
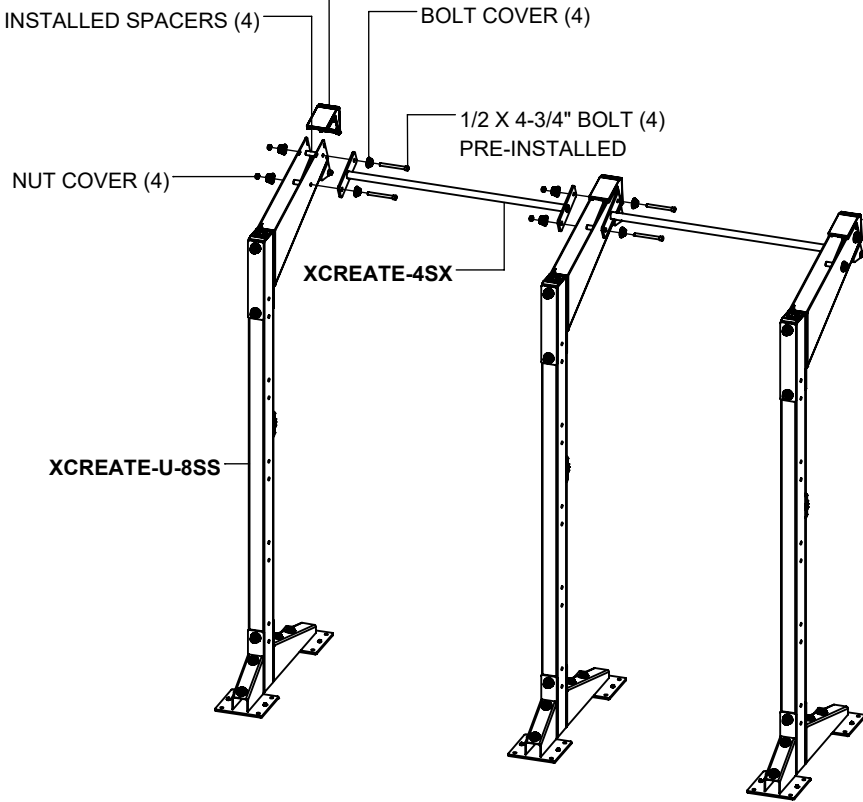

NOTES:

For the purpose of illustration the 4' module extension is shown. The 6' module extension is assembled the same way.

LOOSELY assemble bolt connections in this step.

Repeat this step for as many modules there are to assemble.

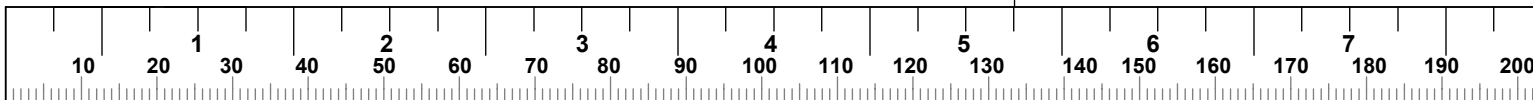

4' / 6' STORAGE MODULE

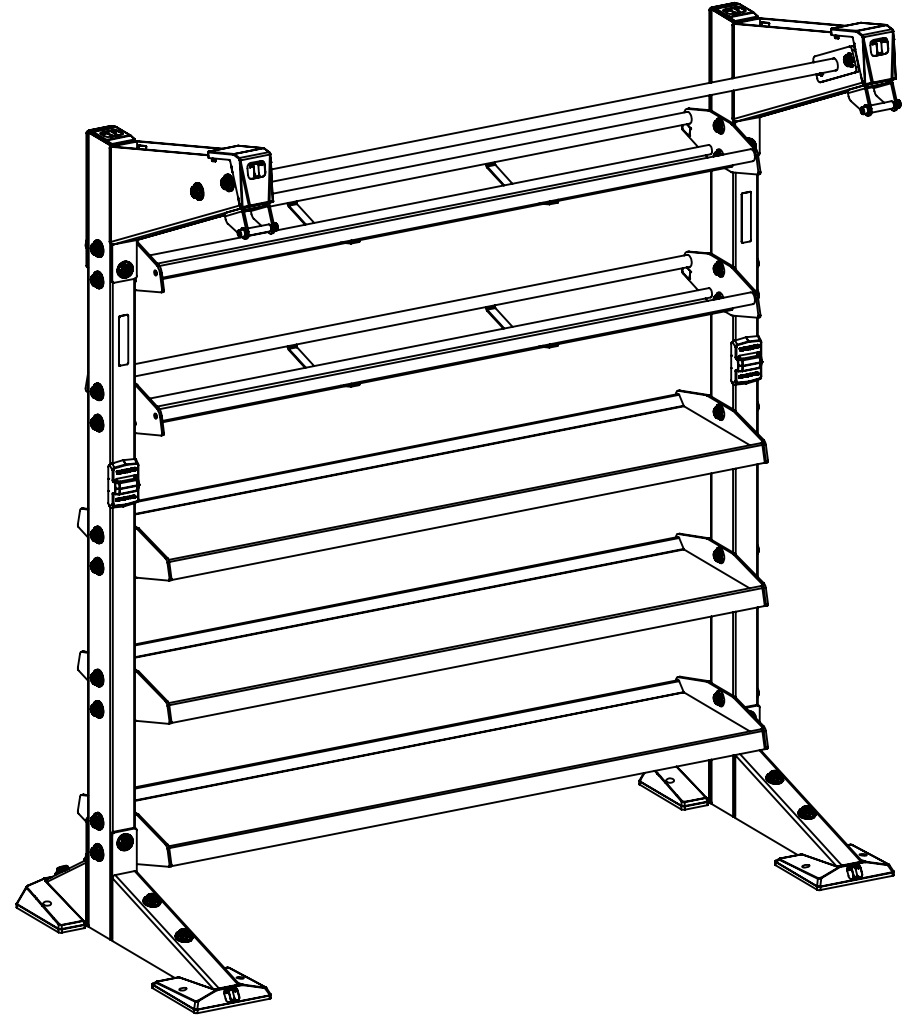
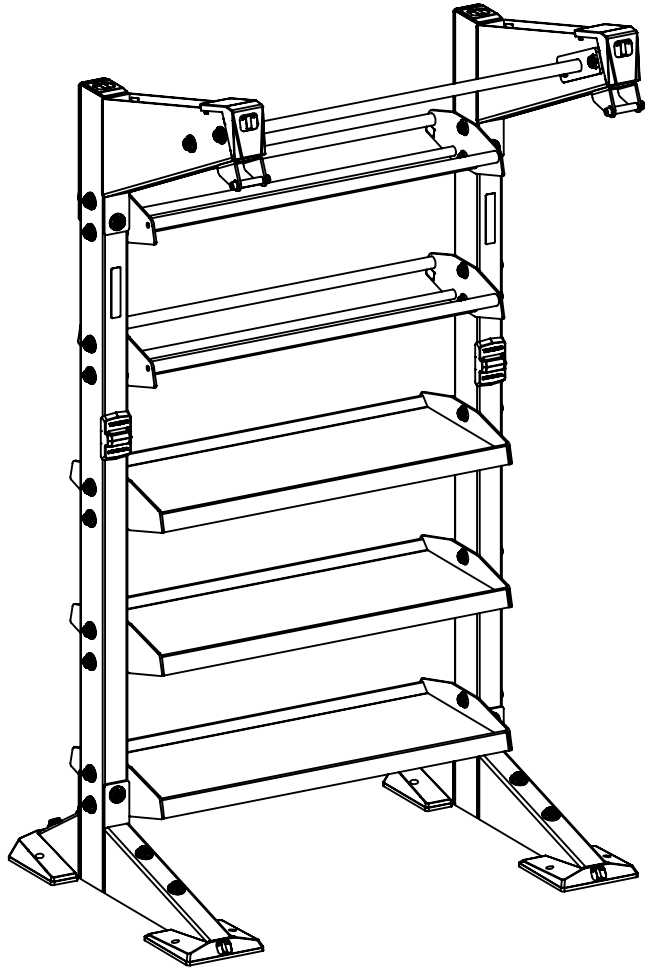

4' / 6' STORAGE MODULE

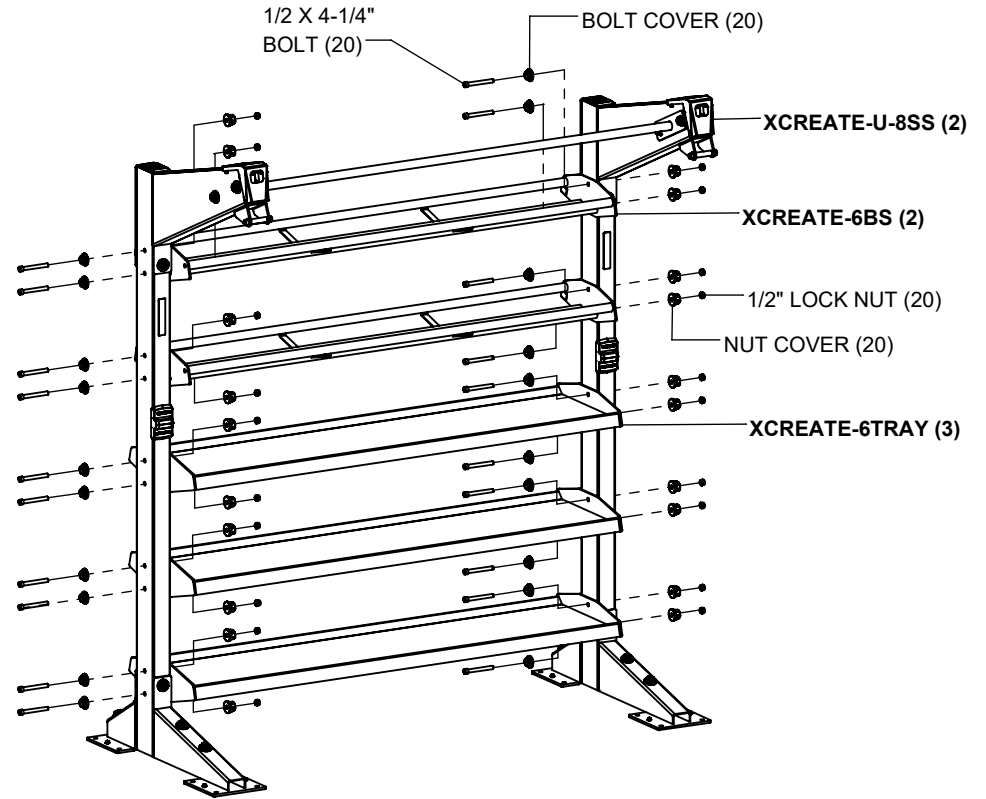
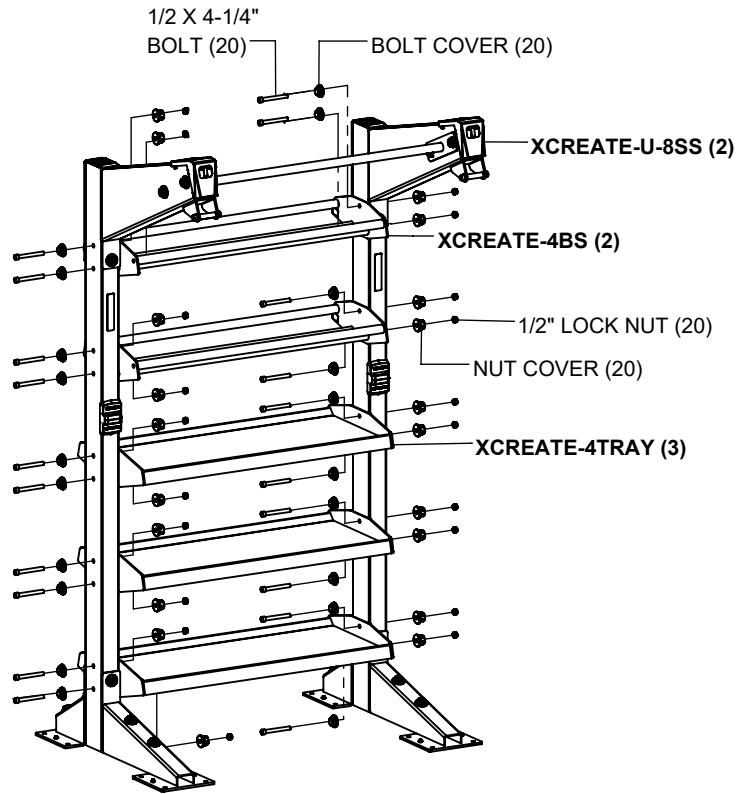

NOTES:

If more modules will be assembled, do not tighten bolts at this time. If this is the only module being assembled, then **SECURELY** tighten all bolts in this step and previous steps.

The **XCREATE-U-7SS** is assembled the exact same way.

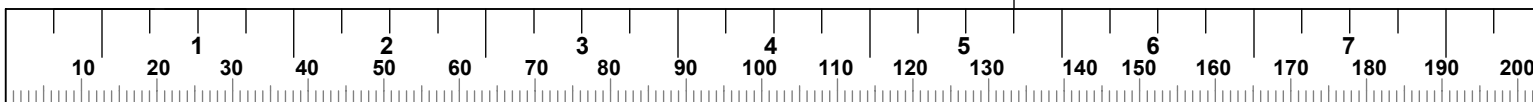

**4' / 6' UNIVERSAL BALL & HANGING
STORAGE MODULE**

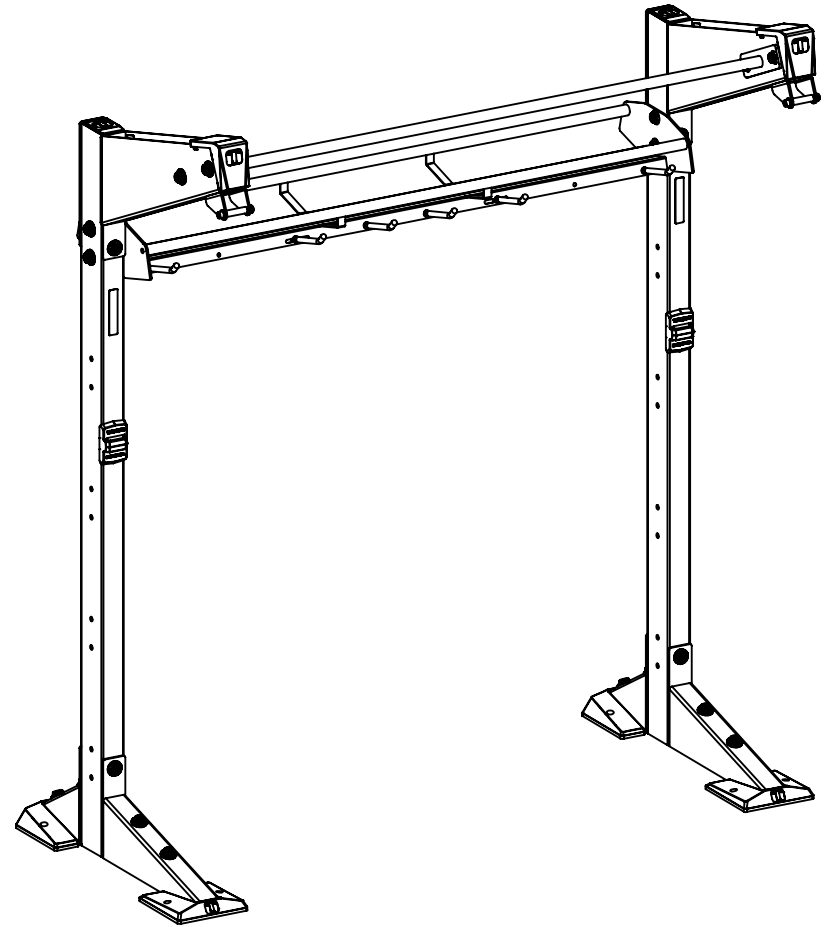
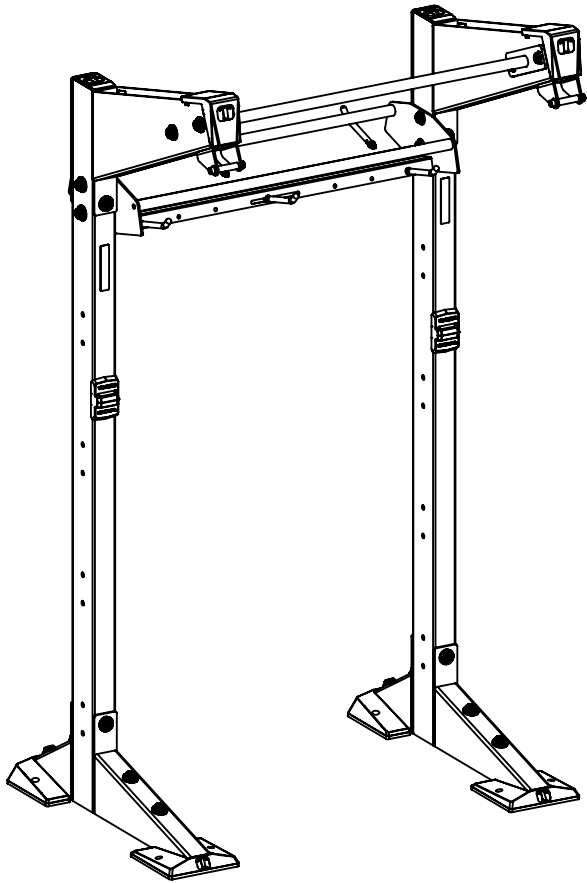

4' / 6' UNIVERSAL BALL & HANGING STORAGE MODULE

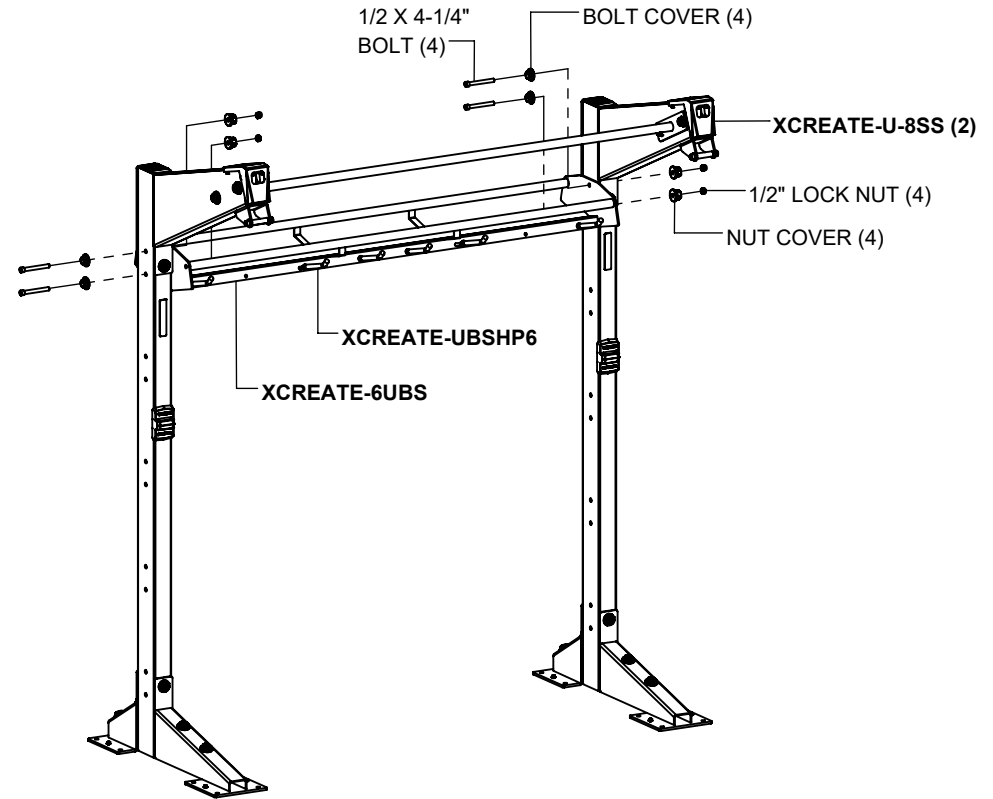
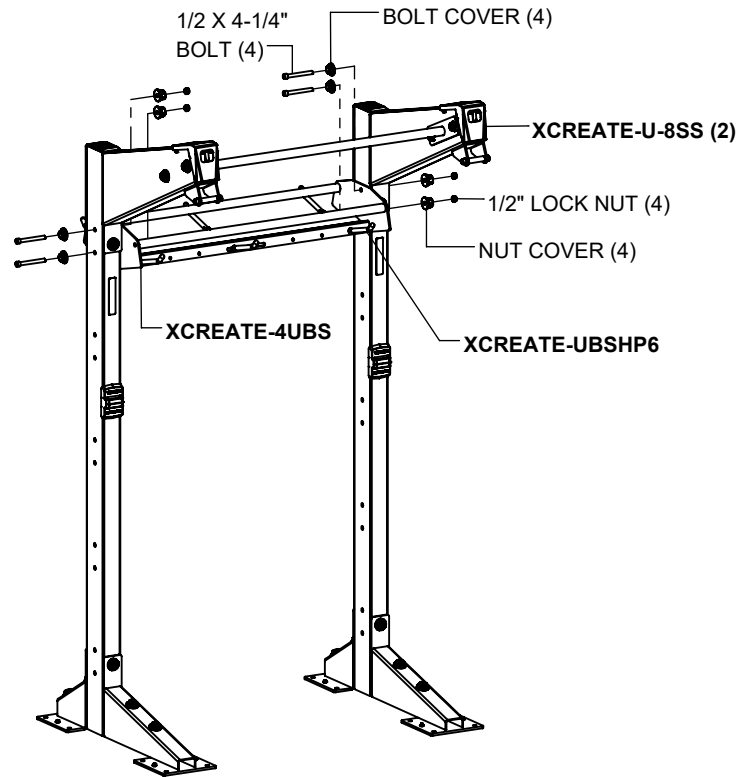

NOTES:

If more modules will be assembled, do not tighten bolts at this time. If this is the only module being assembled, then **SECURELY** tighten all bolts in this step and previous steps.

The **XCREATE-U-7SS** is assembled the exact same way.

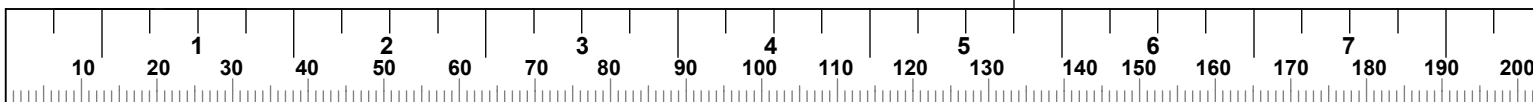

4' STALL BAR MODULE

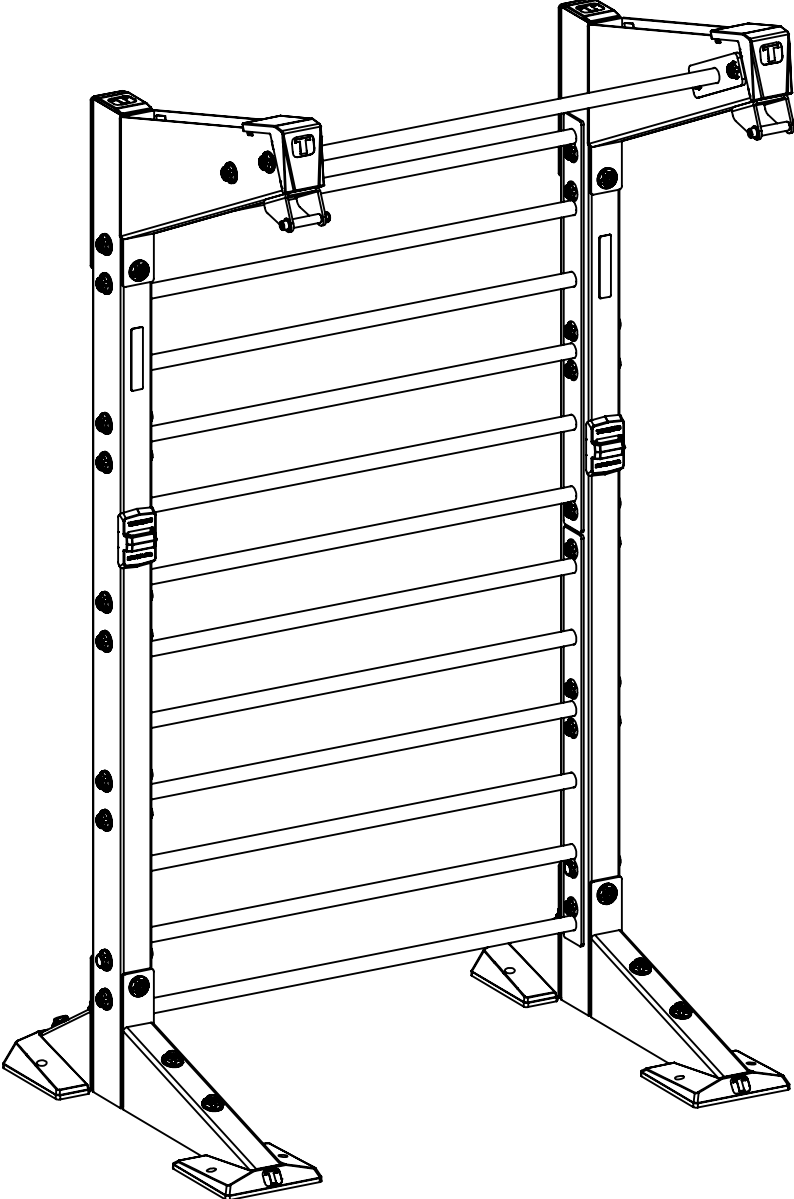

4' STALL BAR MODULE

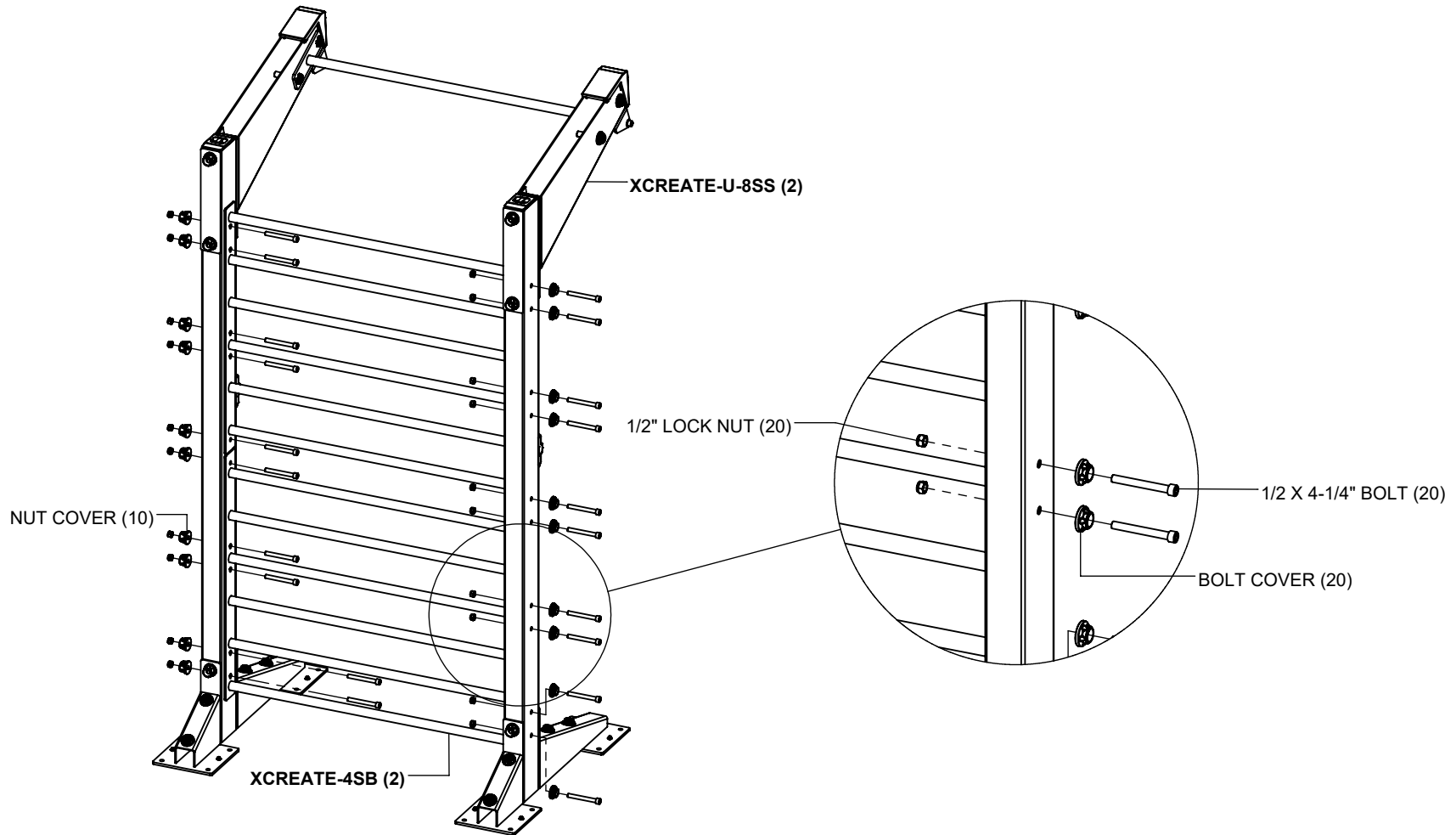

NOTES:

If more modules will be assembled, do not tighten bolts at this time. If this is the only module being assembled, then **SECURELY** tighten all bolts made in this step and previous steps.

HARDWARE COVERS **CAN** be used in place of washers on tube side only. (SEE PAGE 3).

HARDWARE COVERS **CANNOT** be used on plate side.

The **XCREATE-U-7SS** is assembled the exact same way.

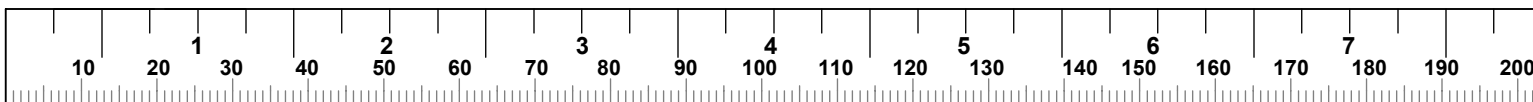

4' BALL TARGET WALL PAD MODULE

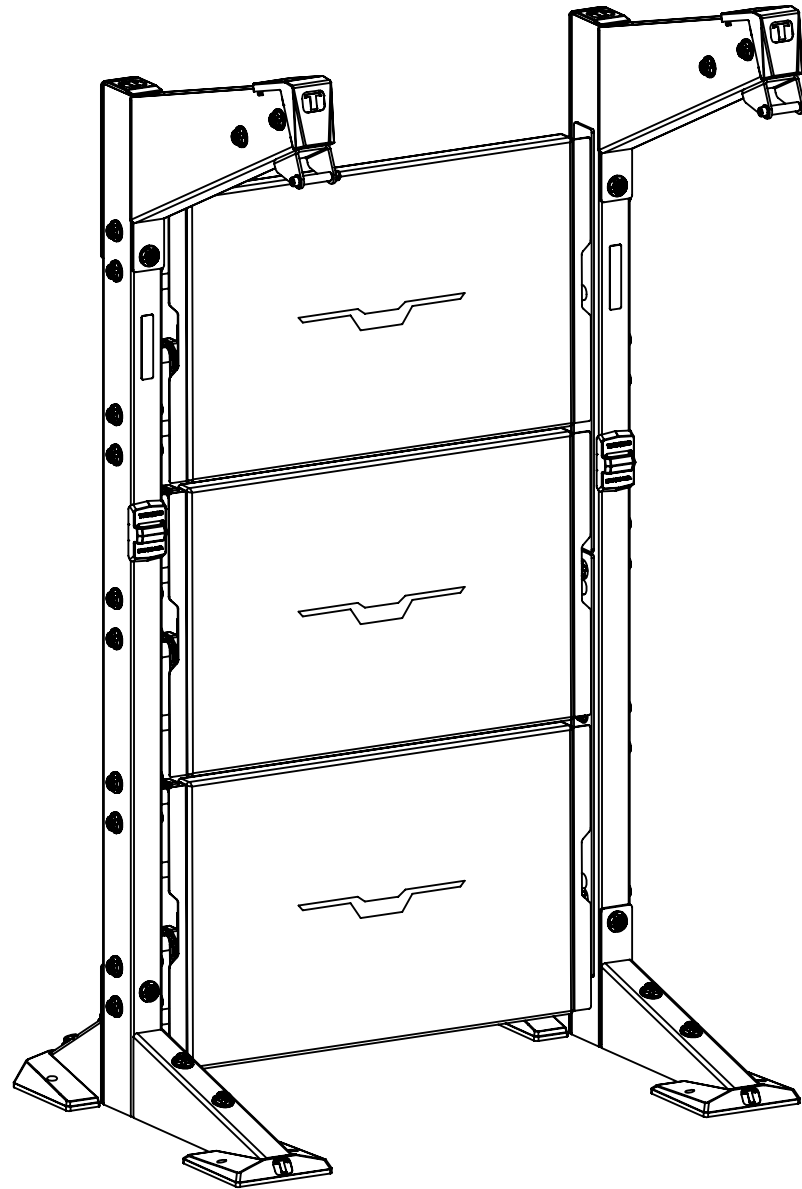

4' BALL TARGET WALL PADS

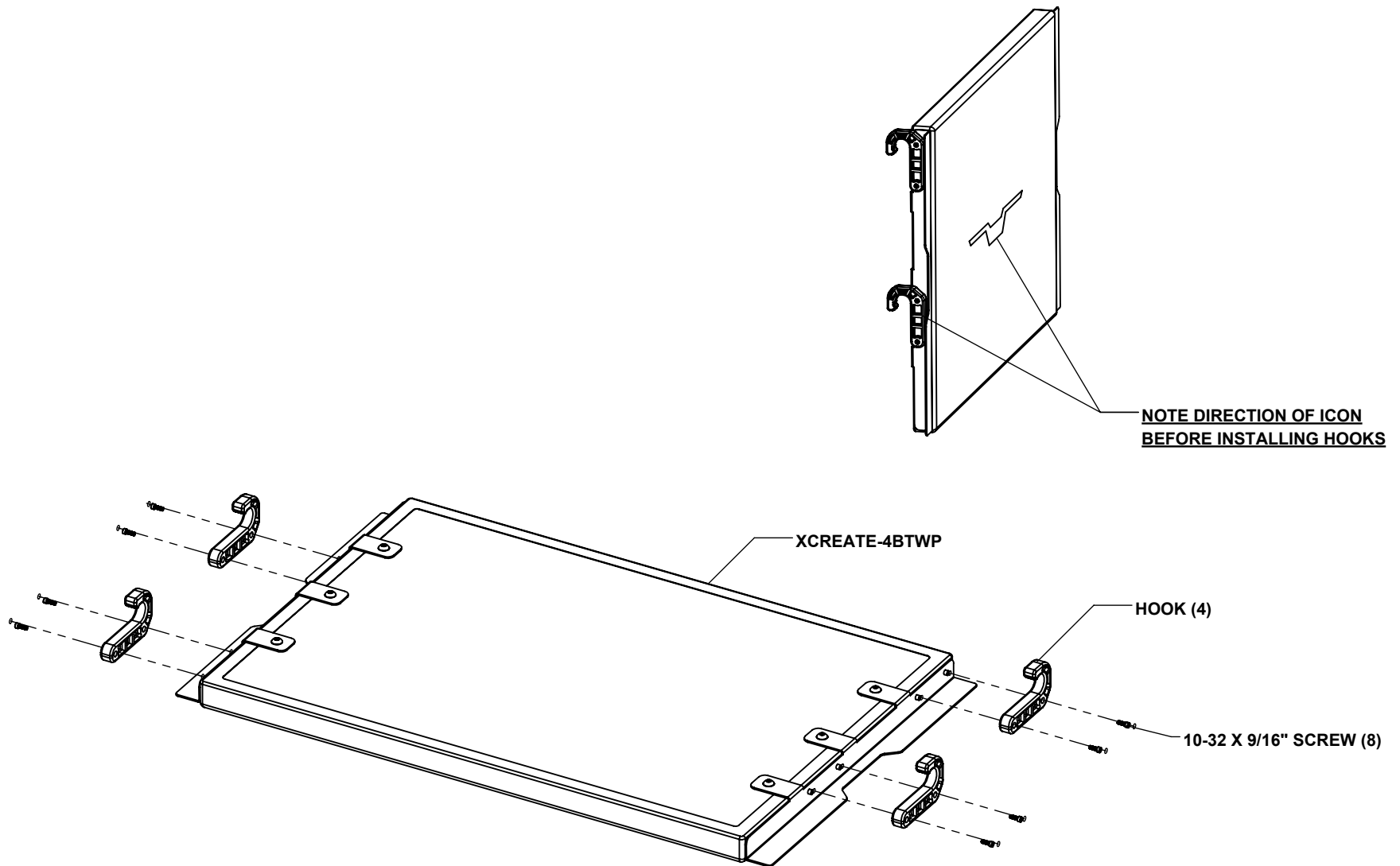

NOTES:

SECURELY TIGHTEN, DO NOT OVER TIGHTEN all bolted connections in this step.

Repeat this step for all ball target pads.

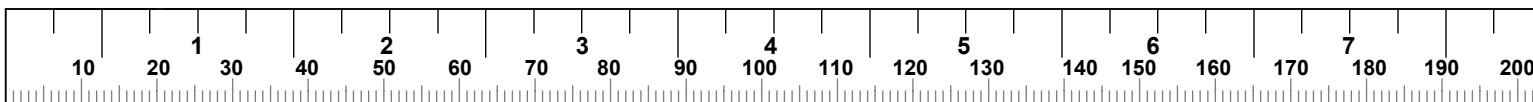

4' BALL TARGET WALL PADS

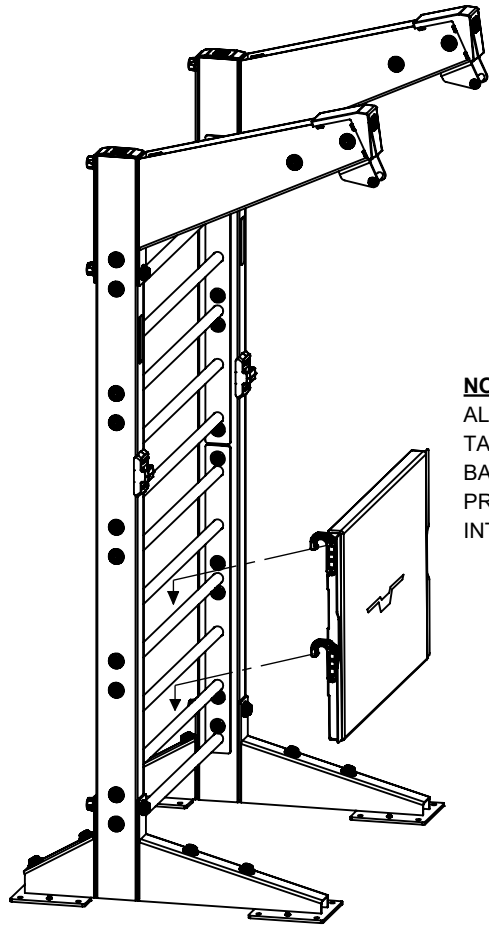

NOTE:
ALIGN AND HOOK BALL
TARGET PADS OVER STALL
BAR CROSSMEMBERS.
PRESS PAD DOWN TO LOCK
INTO PLACE

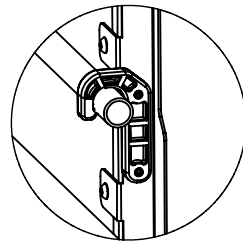

ASSEMBLED
SECTION VIEW

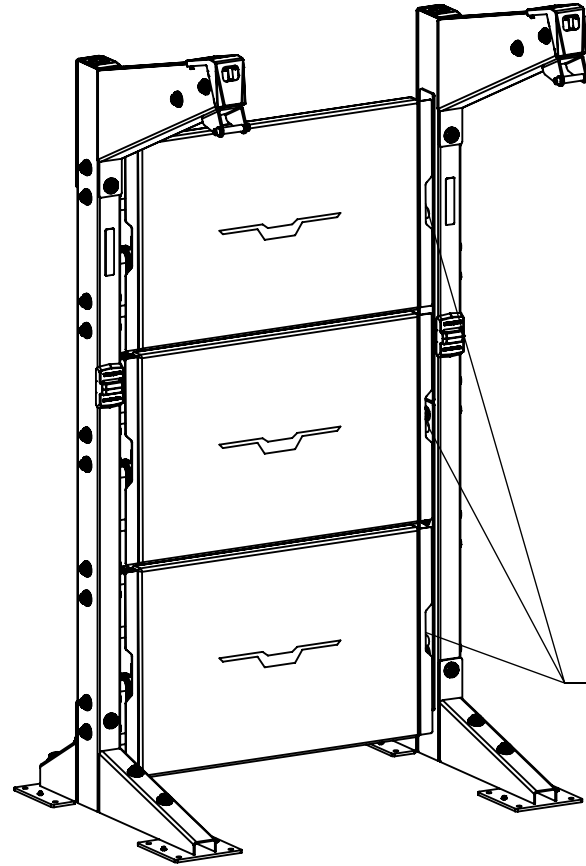

NOTE:
WHEN INSTALLING MULTIPLE
PADS ALWAYS START WITH
THE LOWEST PAD.

NOTES:

XCREATE 4' STALL BAR MODULE is required for installing the ball target wall pads. Reference previous steps for installing the stall bars.

Ball target wall pads can be removed and replaced as needed.

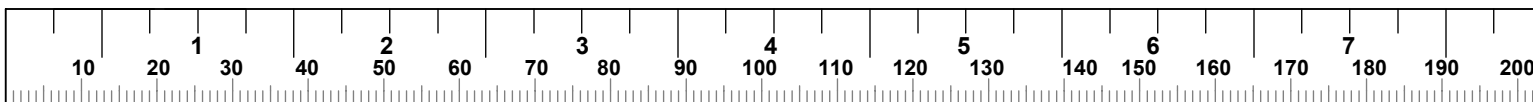

8' OLYMPIC LIFTING STATION MODULE

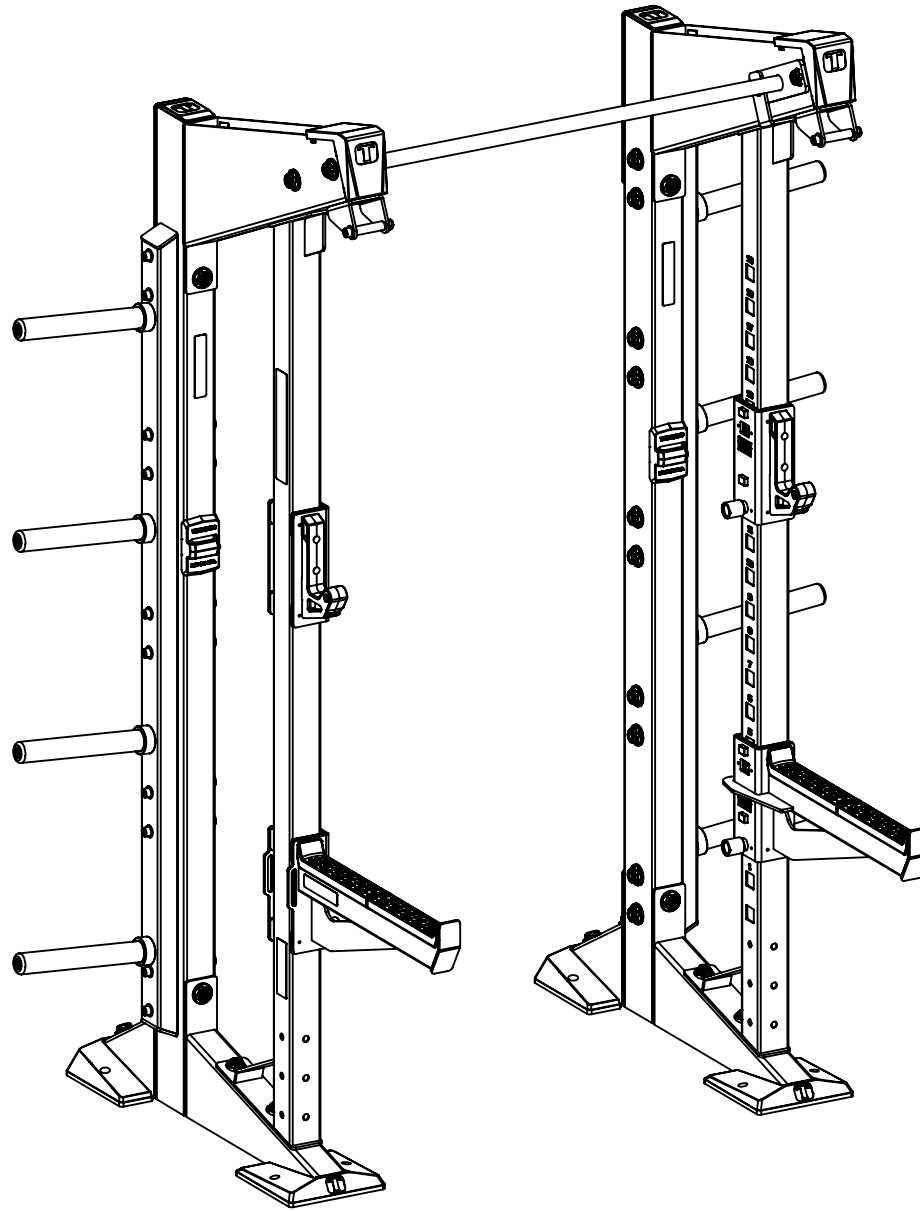

8' OLYMPIC LIFTING STATION MODULE

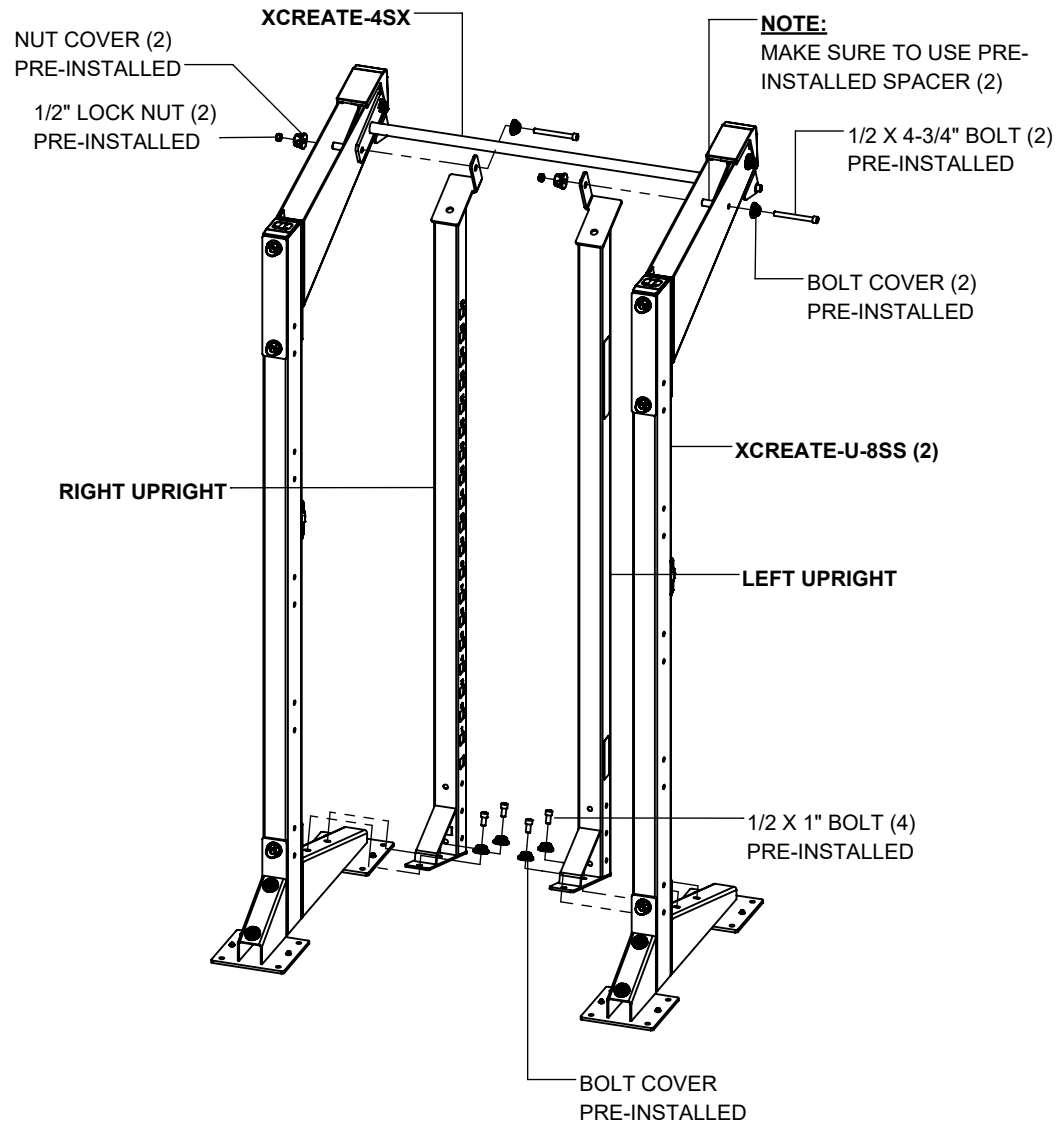

NOTES:

SECURELY tighten all bolt connections in this step.

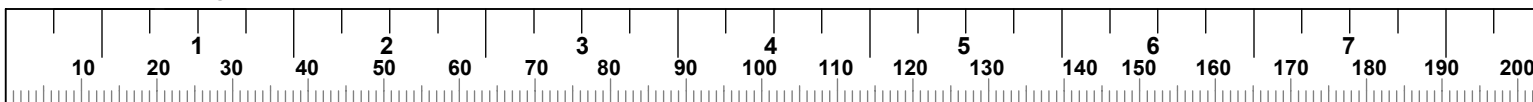

8' OLYMPIC LIFTING STATION MODULE

NOTE:

INSERT BAR SUPPORTS INTO
DESIRED SLOTS ON UPRIGHTS.
PUSH DOWN TO LOCK IN PLACE

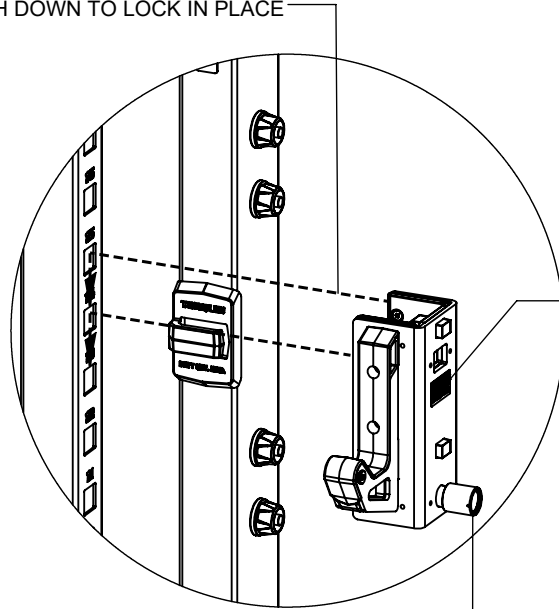

NOTE:

WARNING LABEL

NOTE:

TO REMOVE BAR SUPPORTS FROM
UPRIGHTS, PULL SPRING PIN OUT TO
UNLOCK. LIFT UP AND PULL OUT

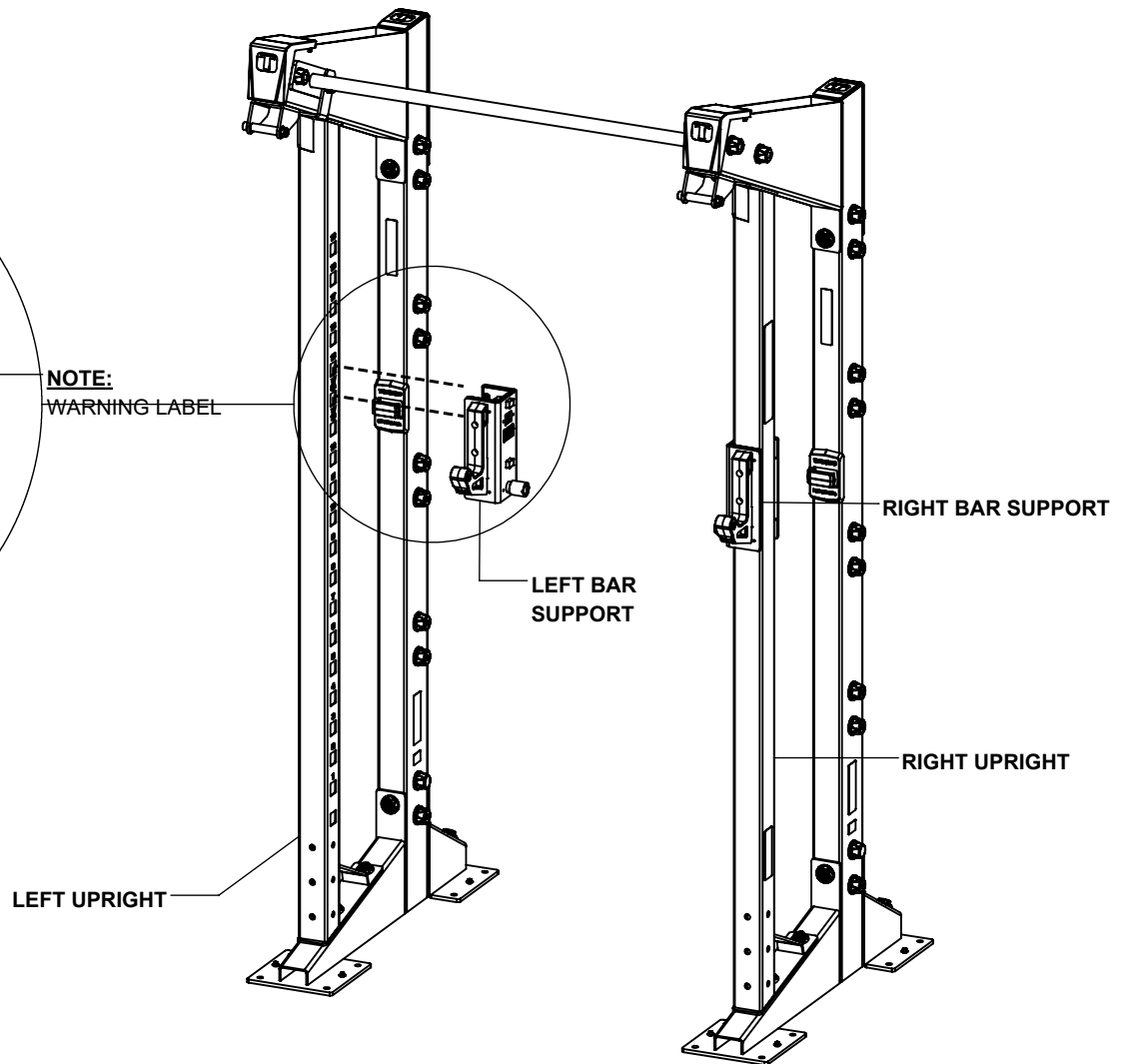

8' OLYMPIC LIFTING STATION MODULE

NOTE:
INSERT BAR CATCHES INTO
DESIRED SLOTS ON UPRIGHTS.
PUSH DOWN TO LOCK IN PLACE

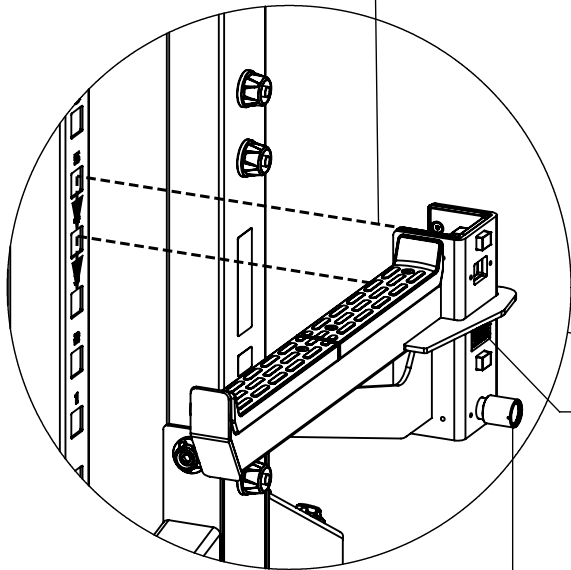

NOTE:
WARNING LABEL

NOTE:
TO REMOVE BAR CATCHES FROM
UPRIGHTS, PULL SPRING PIN OUT TO
UNLOCK. LIFT UP AND PULL OUT

LEFT UPRIGHT

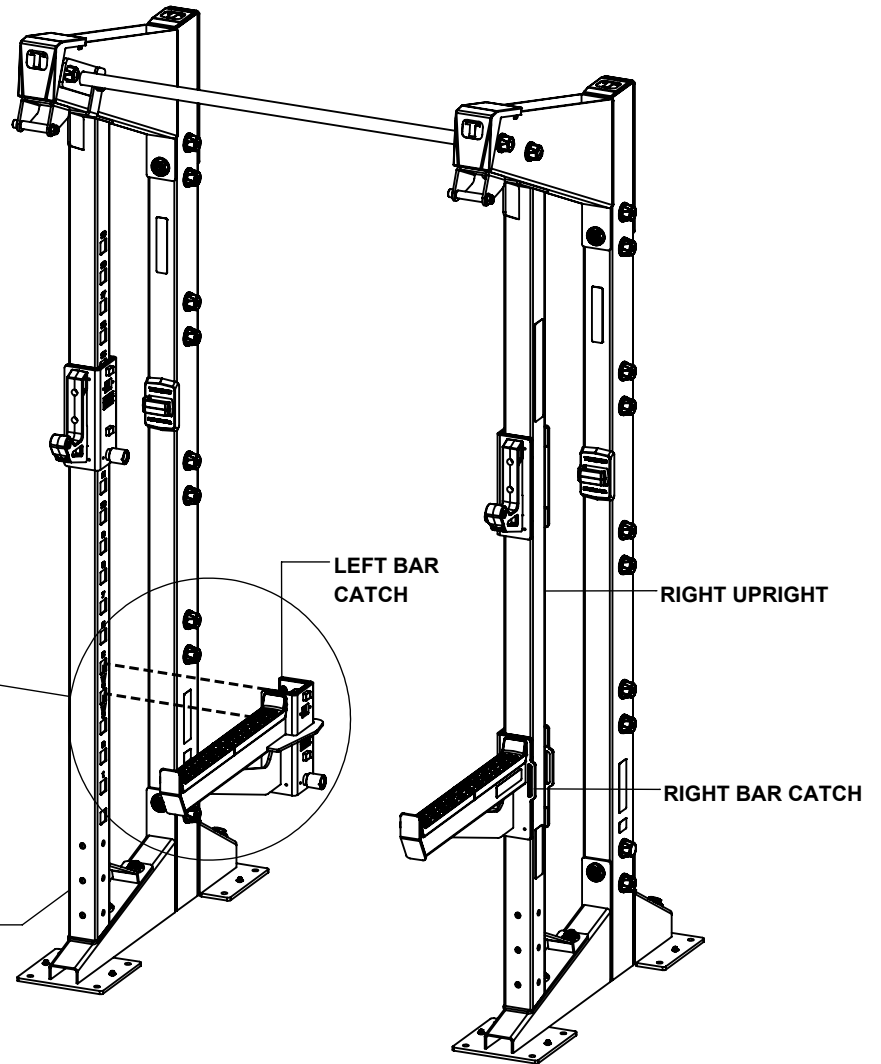

8' OLYMPIC LIFTING STATION MODULE

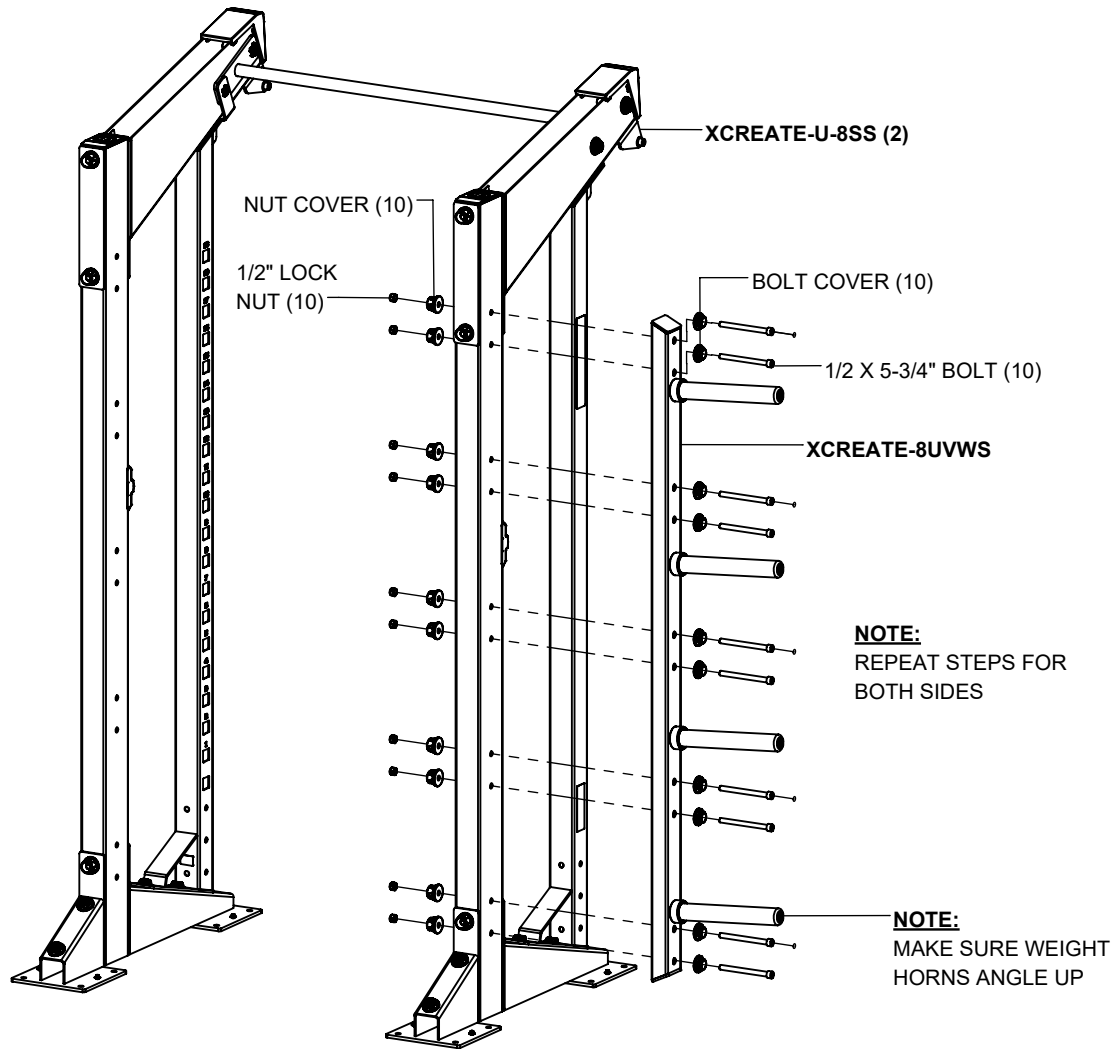

NOTES:

SECURELY tighten all bolt connections in this step.

REPEAT STEPS for both sides as needed.

The **XCREATE-U-7SS** is assembled the exact same way.

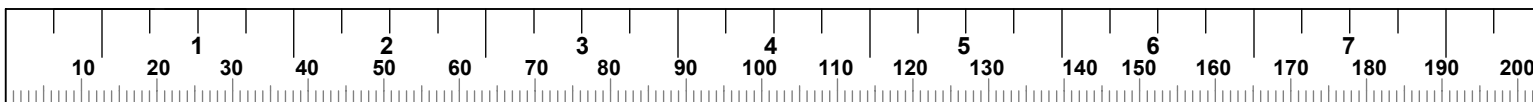

**4' / 6' ACCESSORY & BUMPER BOOKSHELF
STORAGE MODULE**

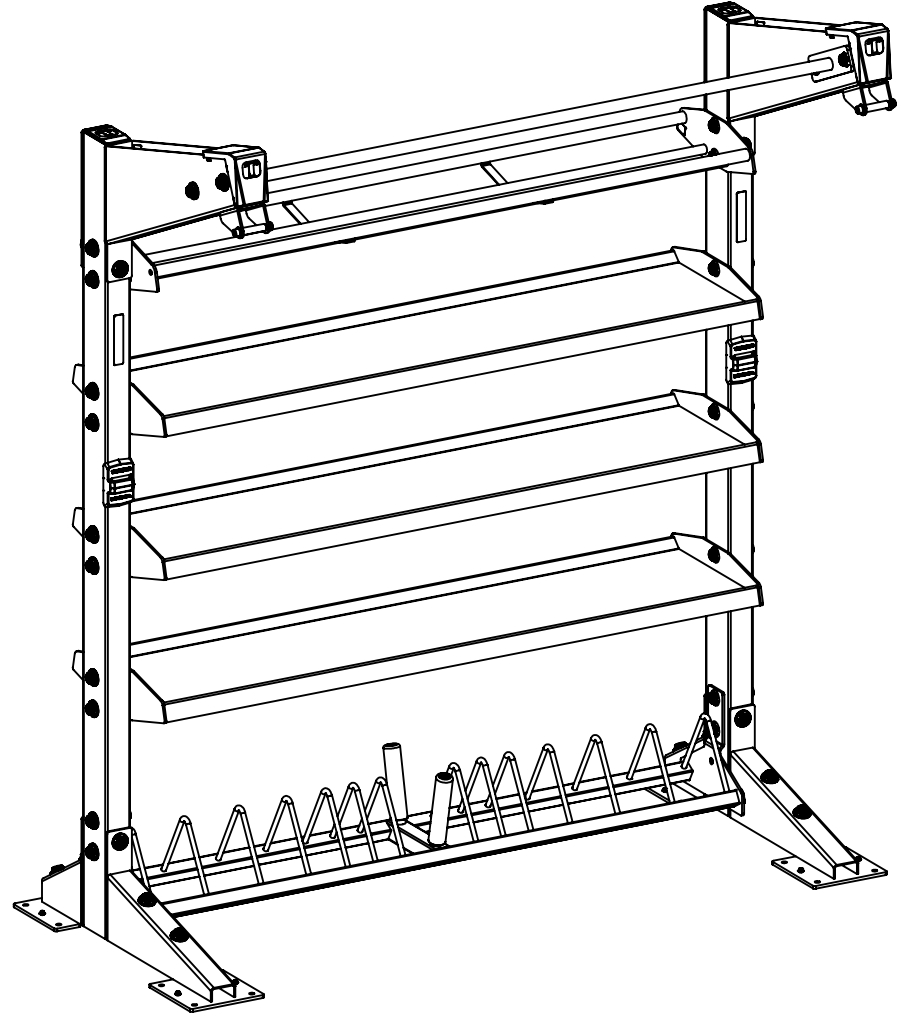
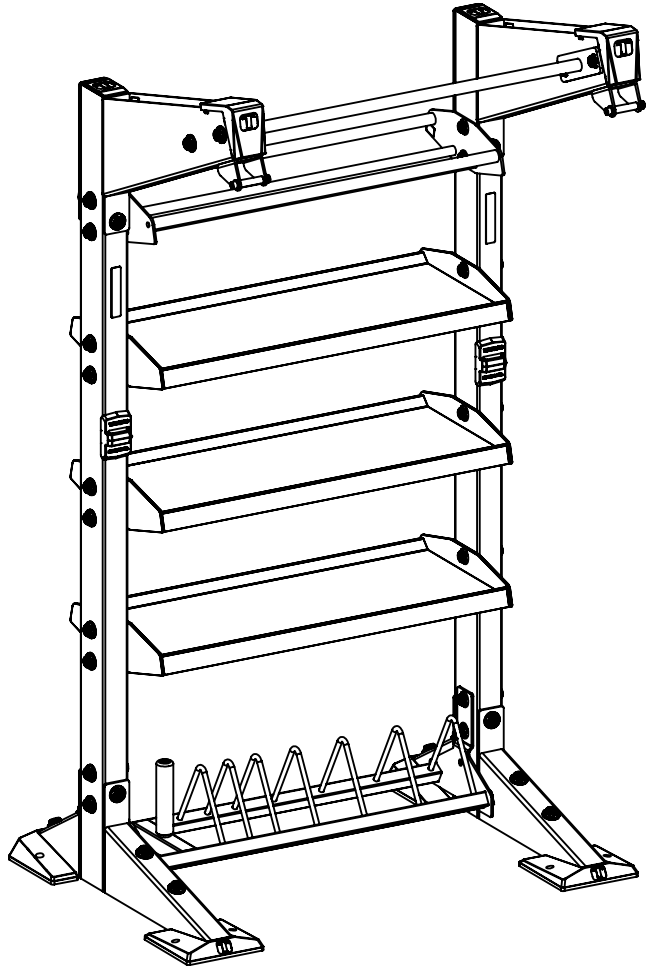

4' / 6' ACCESSORY & BUMPER BOOKSHELF STORAGE MODULE

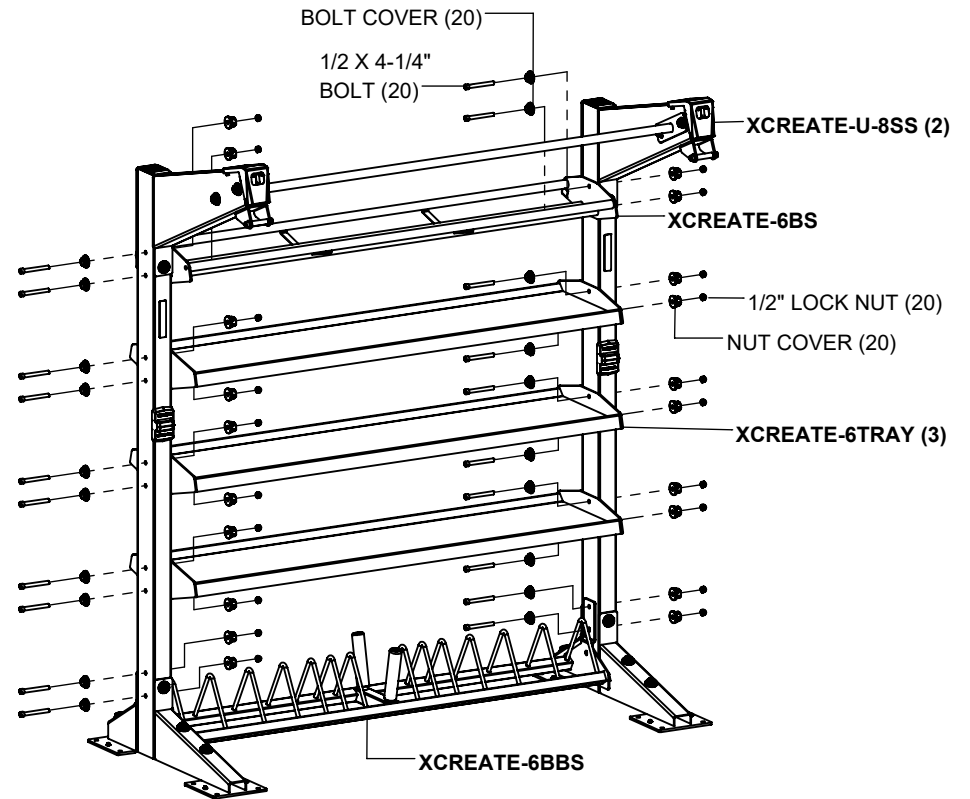
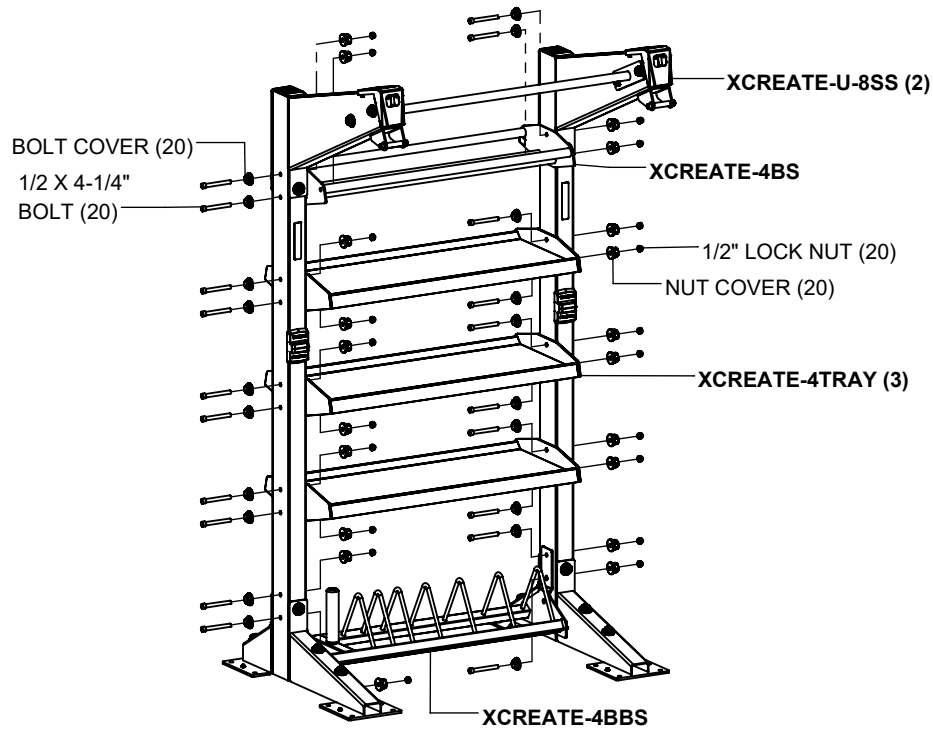

NOTES:

If more modules will be assembled, do not tighten bolts at this time. If this is the only module being assembled, then **SECURELY** tighten all bolts in this step and previous steps.

The **XCREATE-U-7SS** is assembled the exact same way.

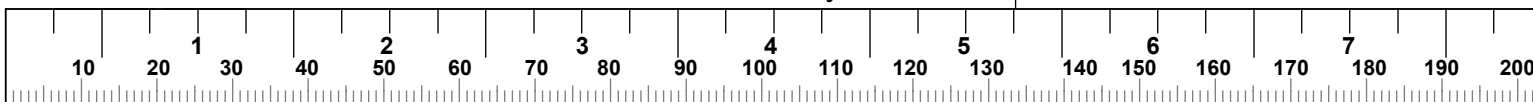

4' TANK DOCKING MODULE

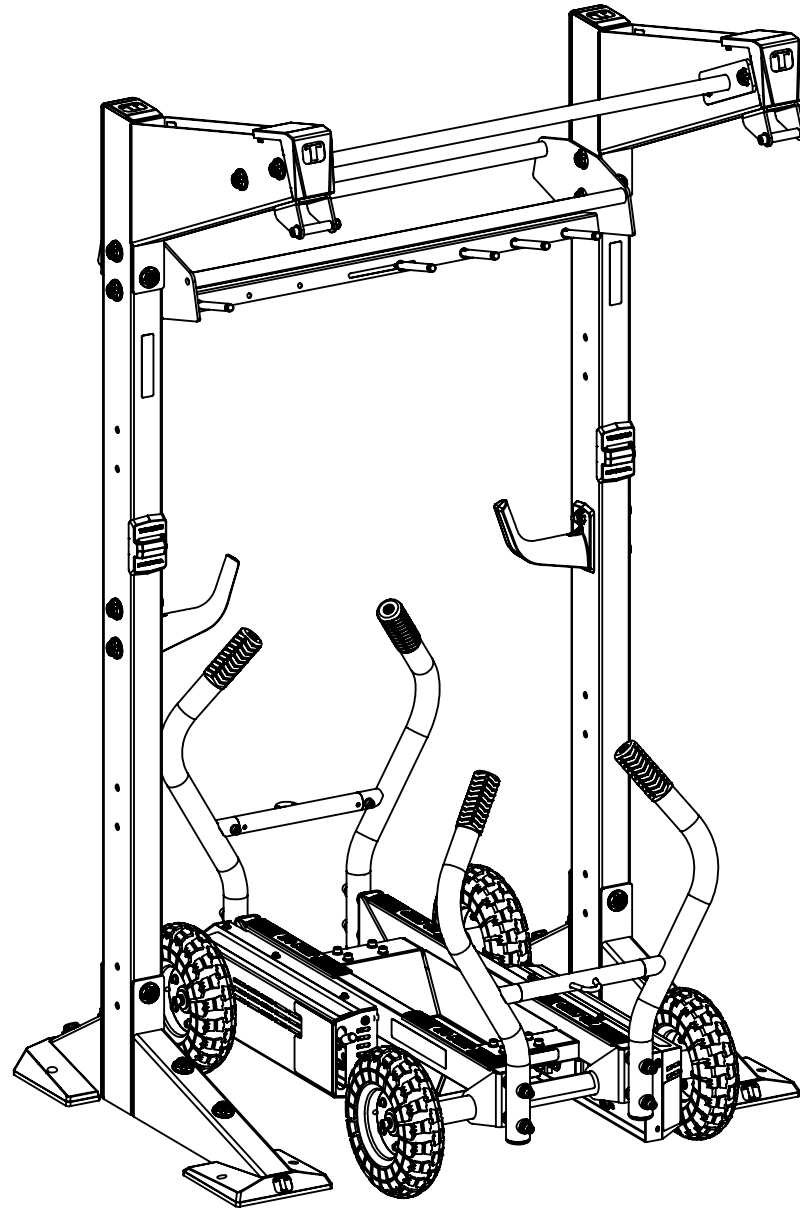

4' TANK DOCKING MODULE

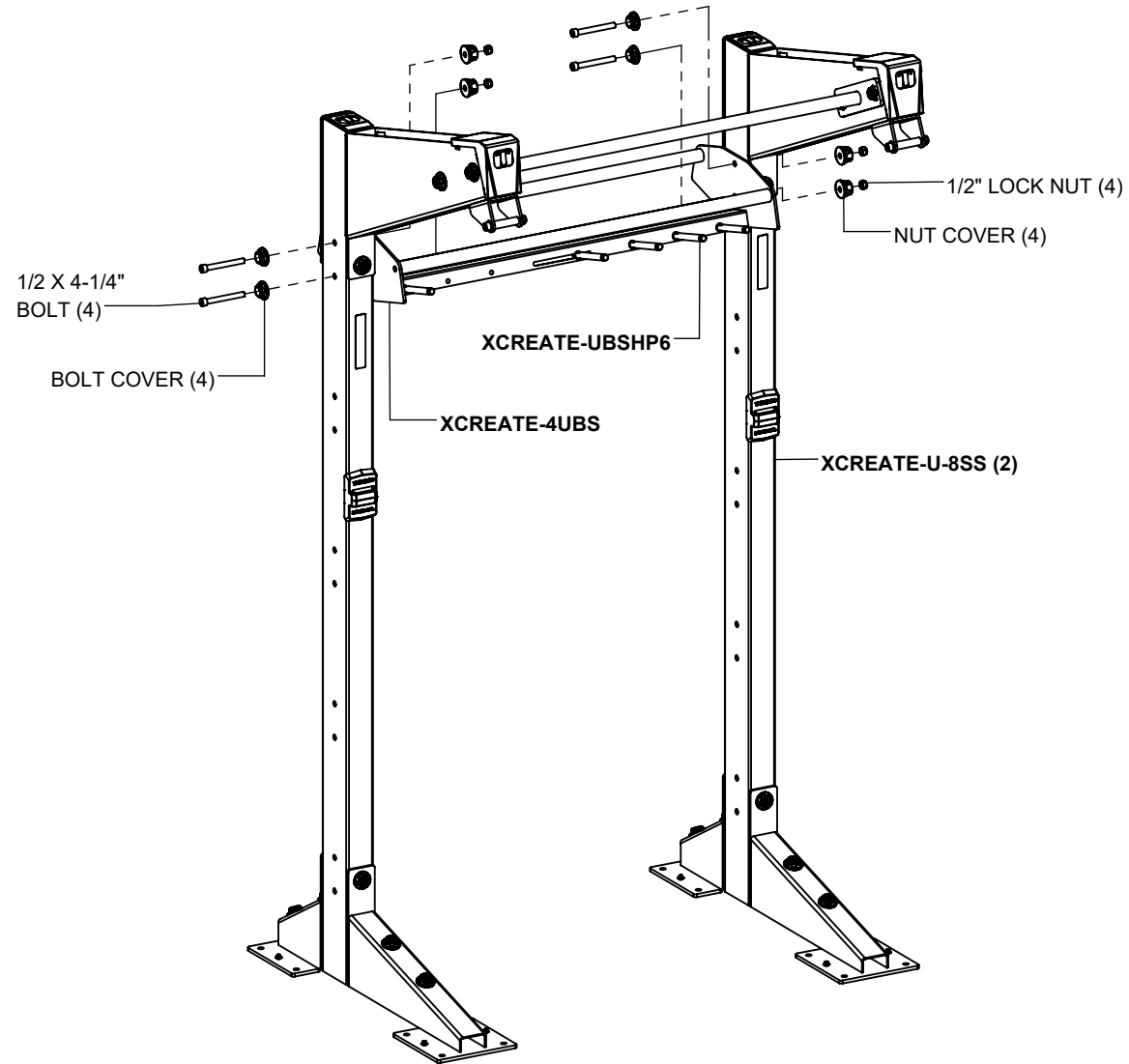

NOTES:

If more modules will be assembled, do not tighten bolts at this time.
If this is the only module being assembled, then **SECURELY** tighten all bolts in this step and previous steps.

The **XCREATE-U-7SS** is assembled the exact same way.

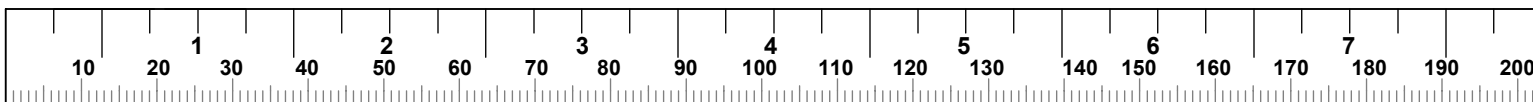

4' TANK DOCKING MODULE

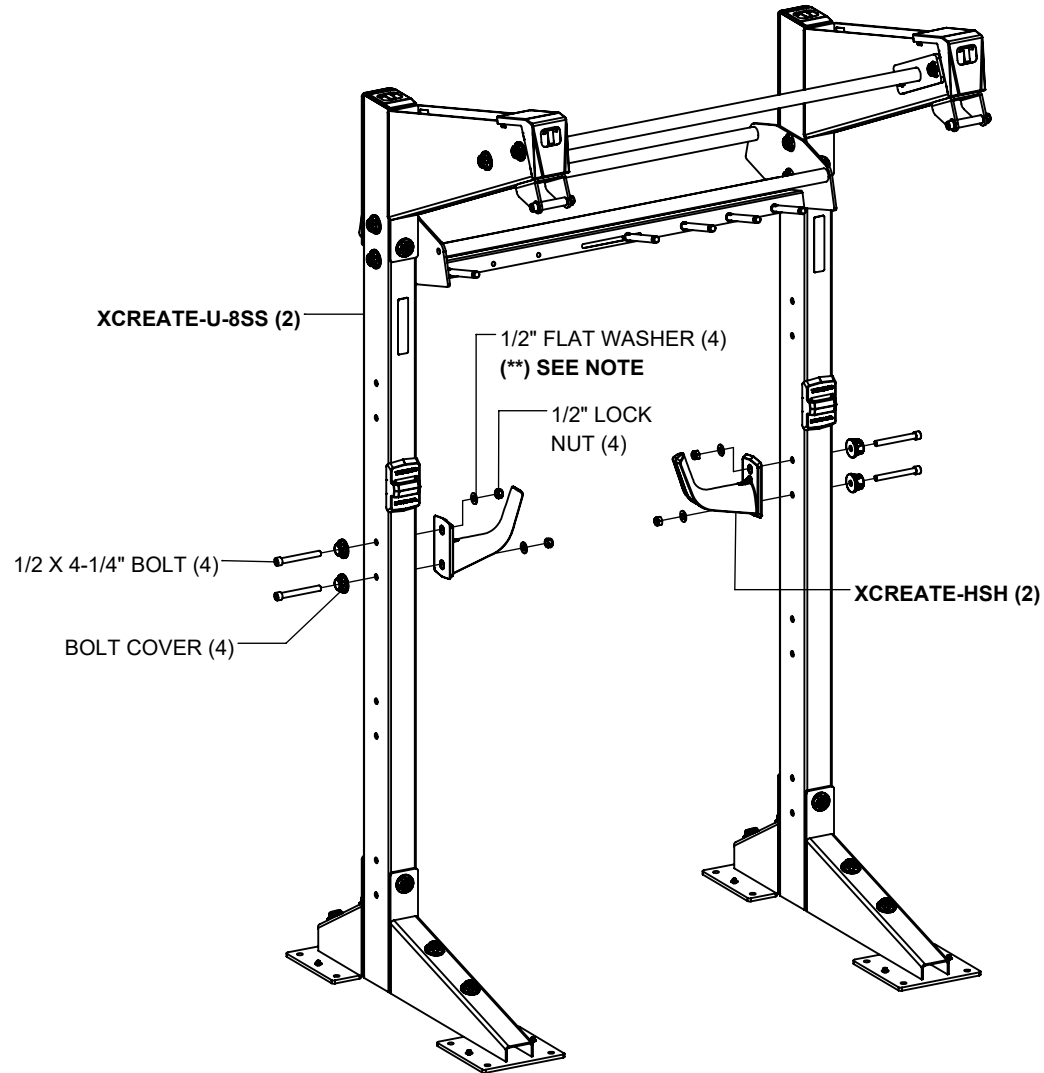

NOTES:

SECURELY tighten all bolt connections in this step.

(**) HARDWARE COVER **CANNOT** be used on **HSH** side.

The **XCREATE-U-7SS** is assembled the exact same way.

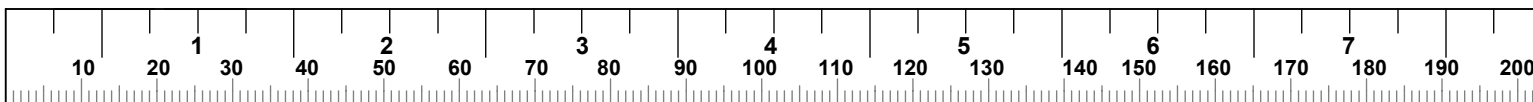

4' TANK DOCKING MODULE

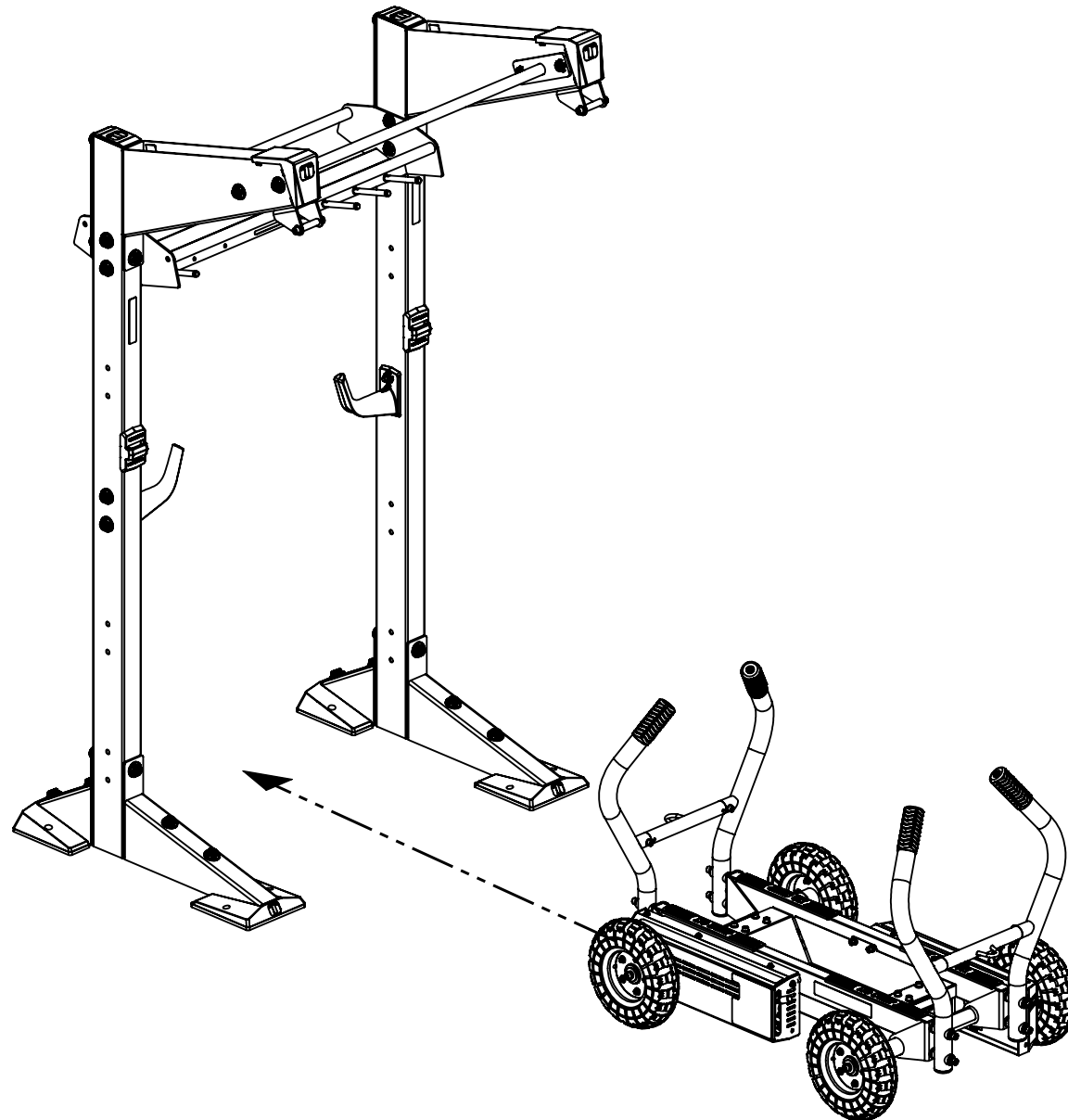

4' X 5' BARBELL STORAGE MODULE

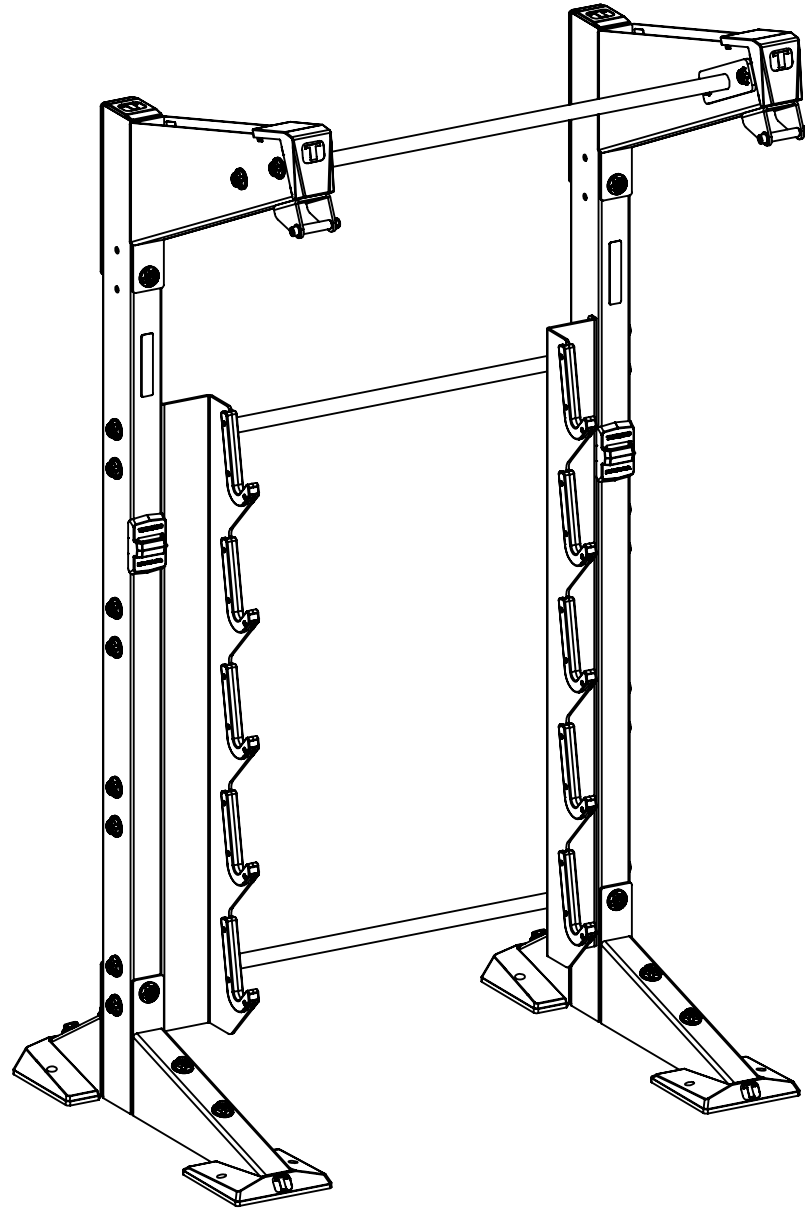

4' X 5 BARBELL STORAGE MODULE (WITHOUT CONNECTOR)

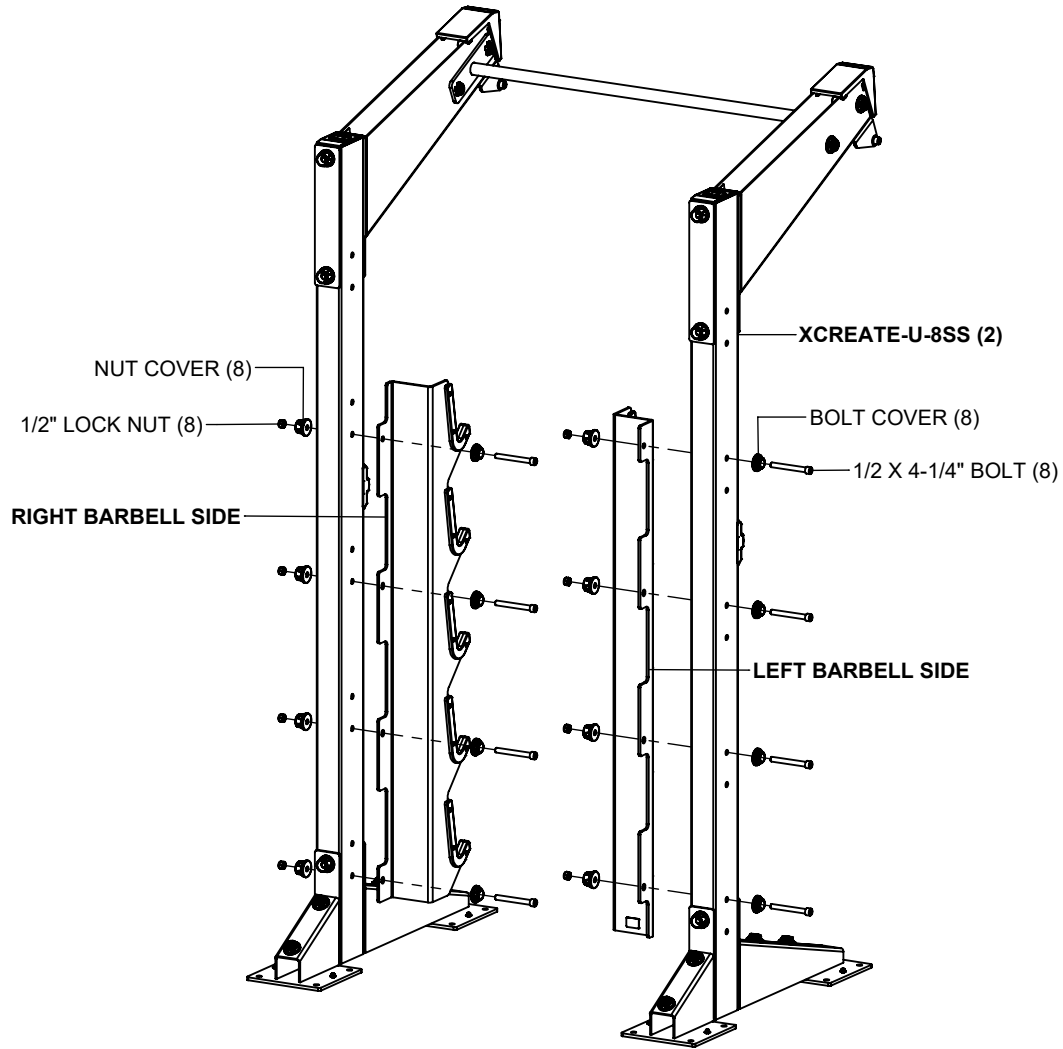

NOTES:

If more modules will be assembled, do not tighten bolts at this time.
If this is the only module being assembled, then **SECURELY** tighten all bolts in this step and previous steps.

The **XCREATE-U-7SS** is assembled the exact same way.

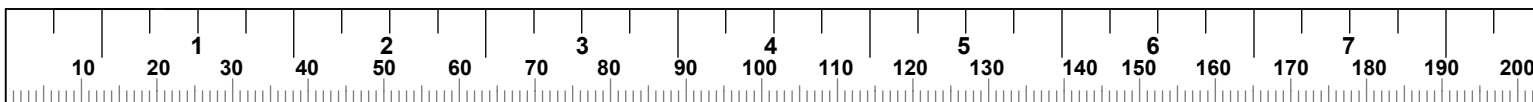

4' X 5' BARBELL STORAGE MODULE (WITH CONNECTOR)

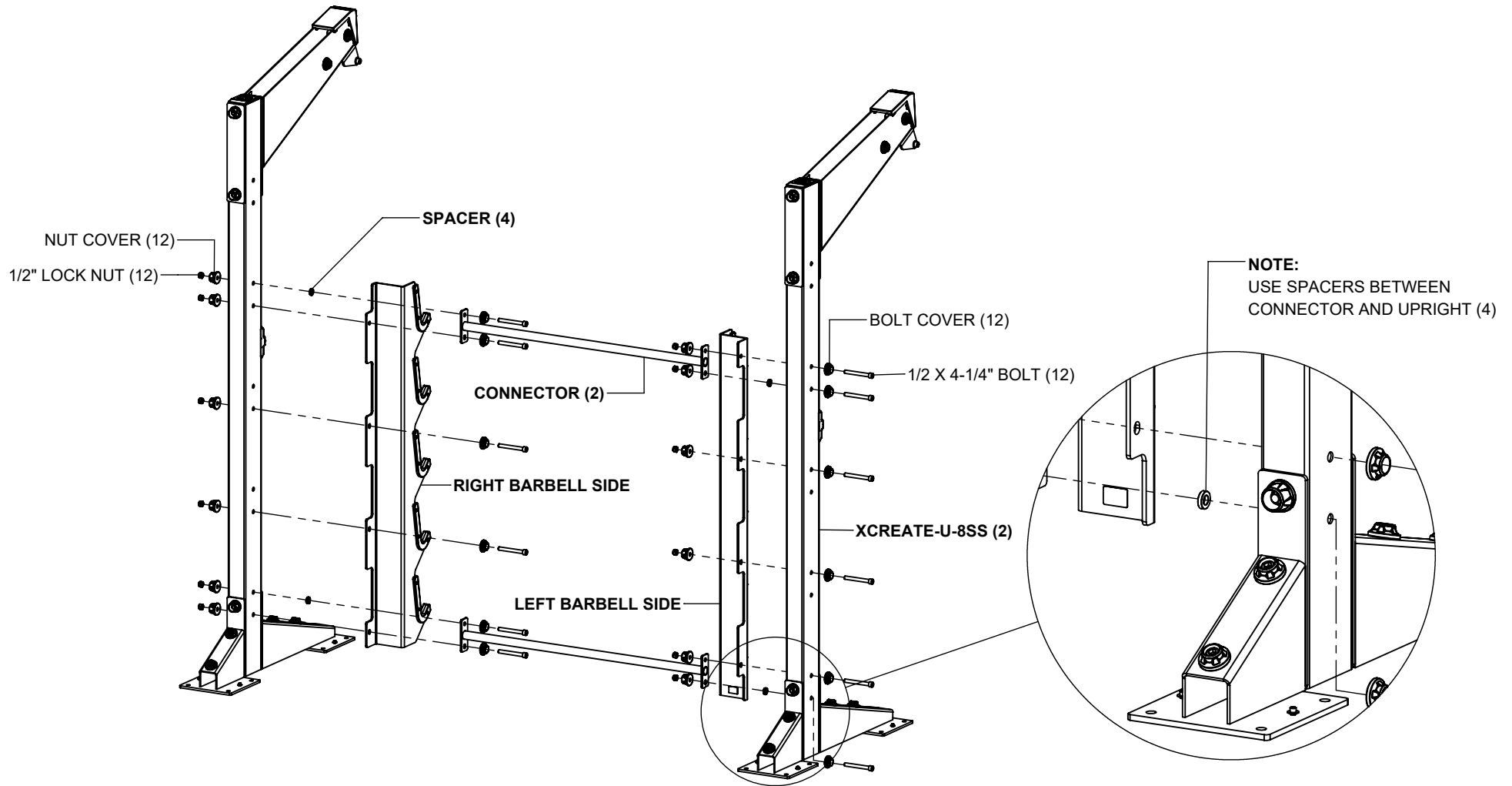

NOTES:

If more modules will be assembled, do not tighten bolts at this time. If this is the only module being assembled, then **SECURELY** tighten all bolts in this step and previous steps.

The **XCREATE-U-7SS** is assembled the exact same way.

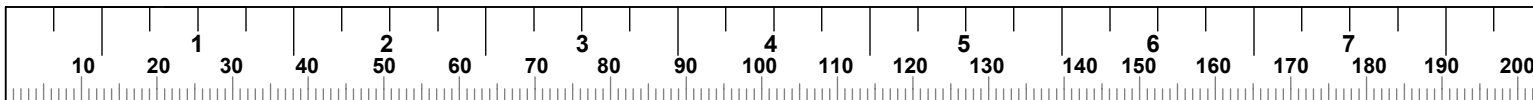

4' X 5' BARBELL STORAGE MODULE

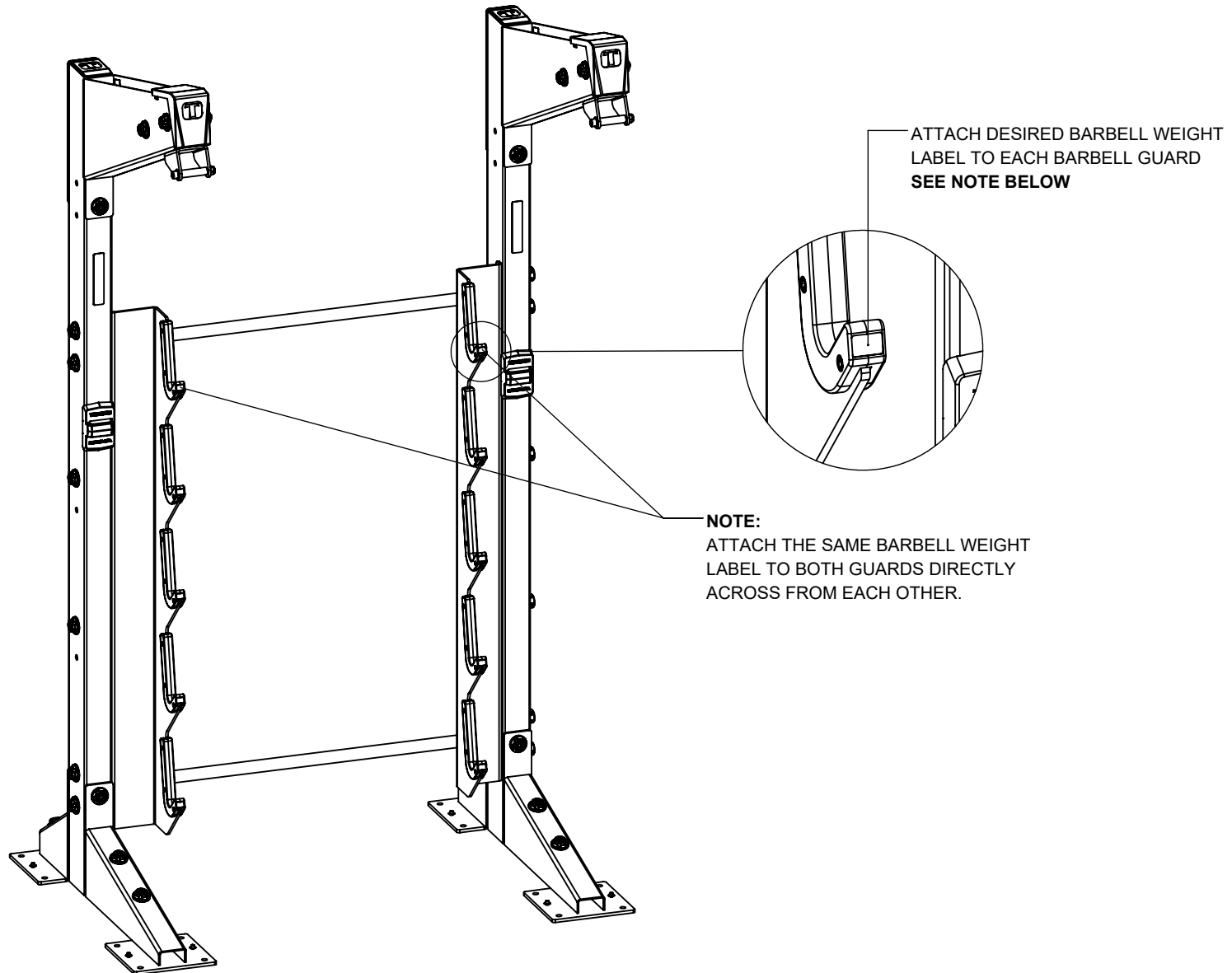

NOTE:

If you are a professional contractor installing this system for a facility, leave these labels and instruction with manager or inquire what label to attach to each barbell guard.

4' X 10 BARBELL STORAGE MODULE

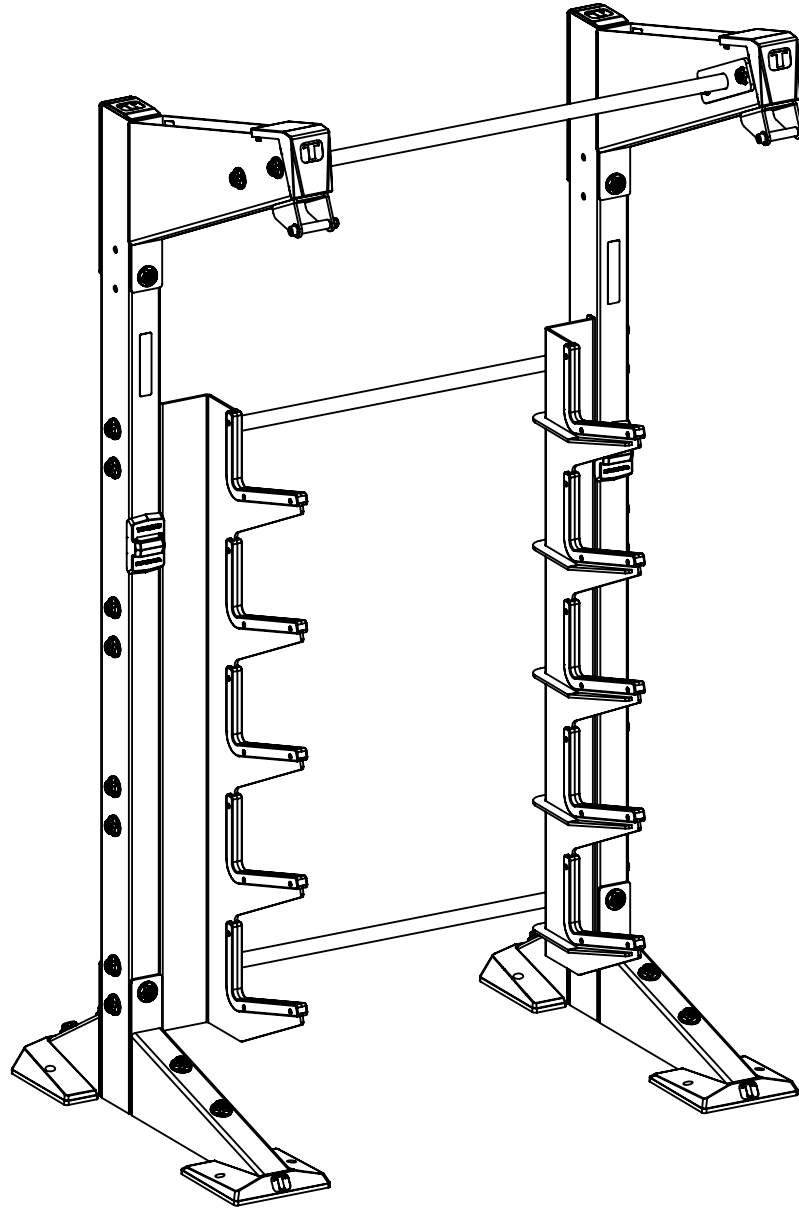

4' X 10 BARBELL STORAGE MODULE (WITHOUT CONNECTOR)

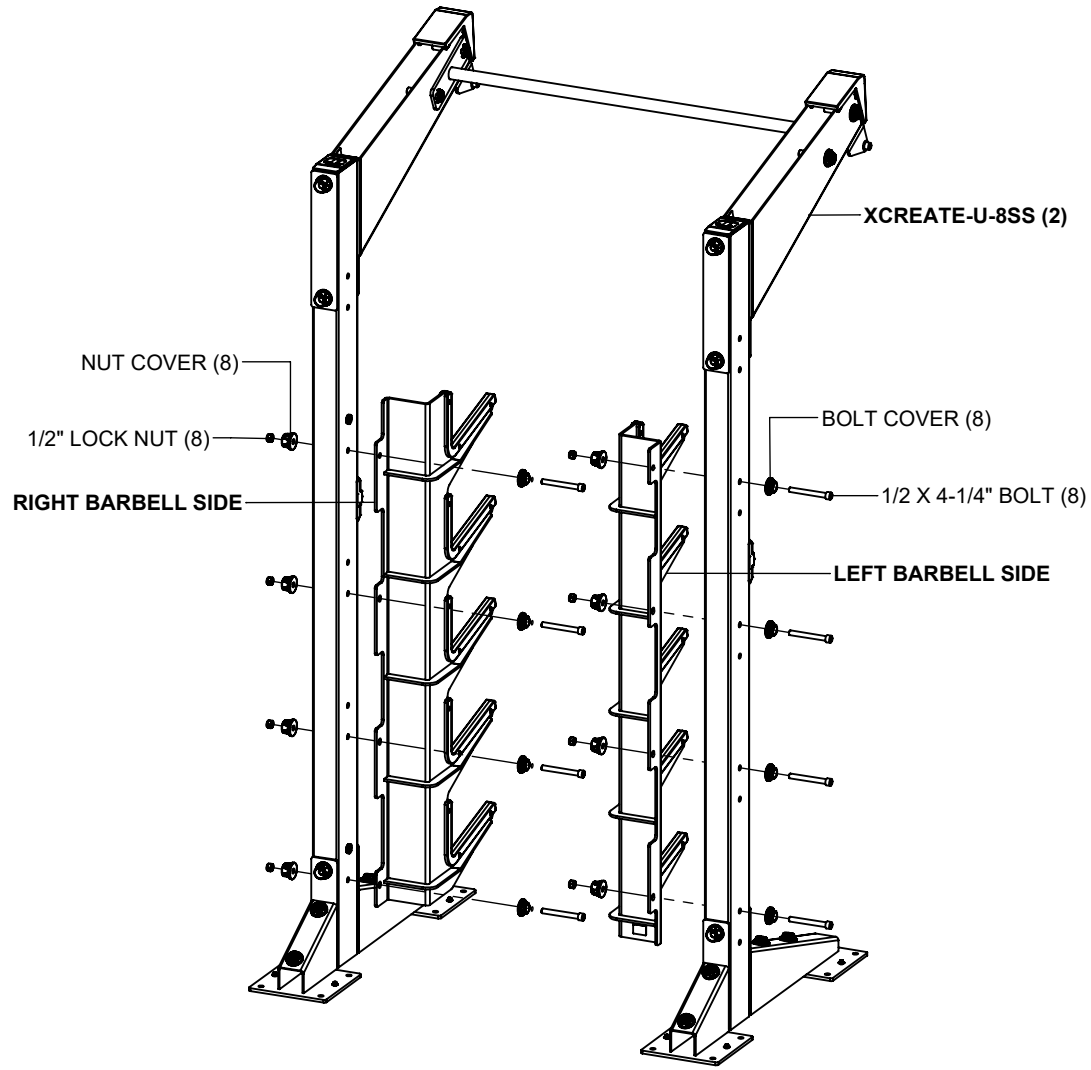

NOTES:

If more modules will be assembled, do not tighten bolts at this time.
If this is the only module being assembled, then **SECURELY** tighten all bolts in this step and previous steps.

The **XCREATE-U-7SS** is assembled the exact same way.

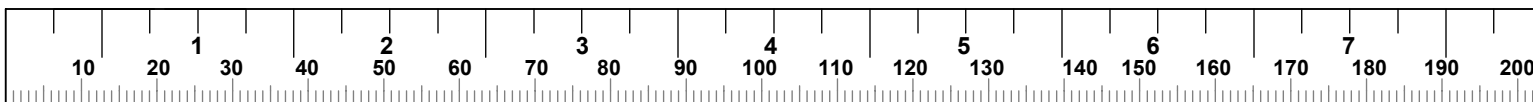

4' X 10 BARBELL STORAGE MODULE (WITH CONNECTOR)

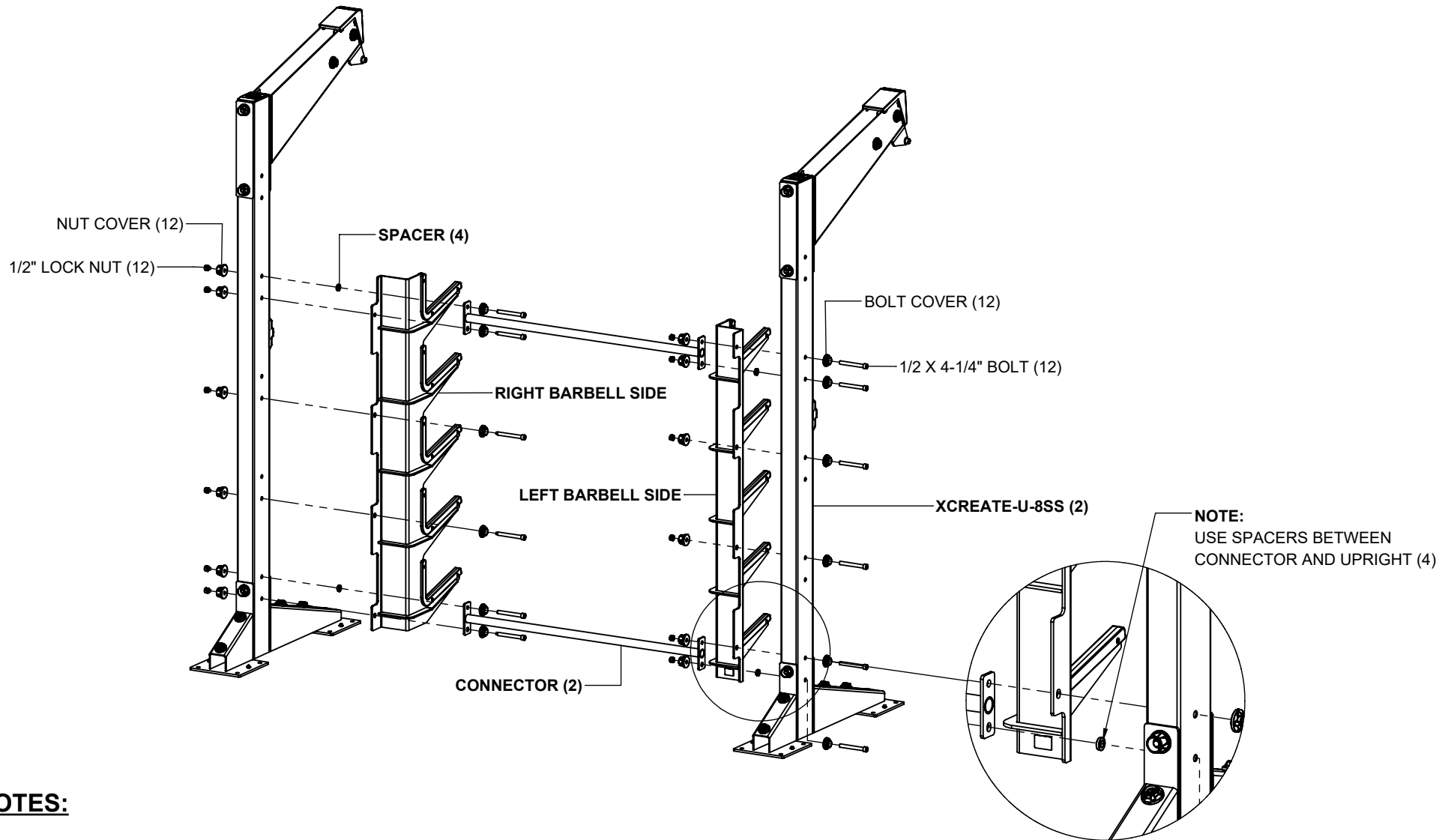

NOTES:

If more modules will be assembled, do not tighten bolts at this time.
If this is the only module being assembled, then **SECURELY** tighten all bolts in this step and previous steps.

The **XCREATE-U-7SS** is assembled the exact same way.

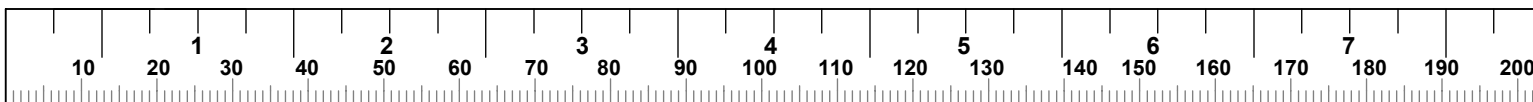

4' X 10 BARBELL STORAGE MODULE

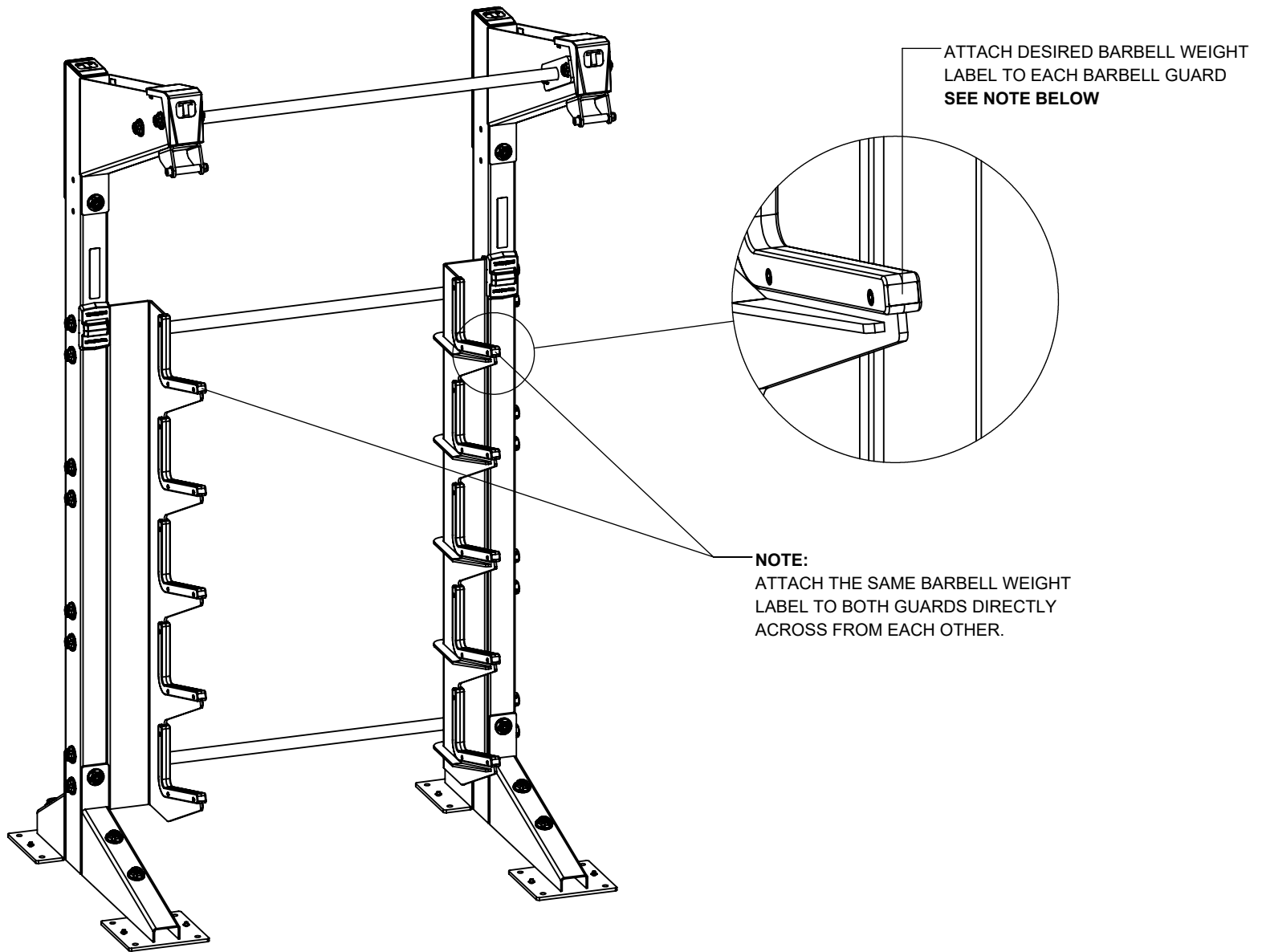

NOTE:

If you are a professional contractor installing this system for a facility, leave these labels and instruction with manager or inquire what label to attach to each barbell guard.

4' 2 SIDED X 10 BARBELL STORAGE MODULE

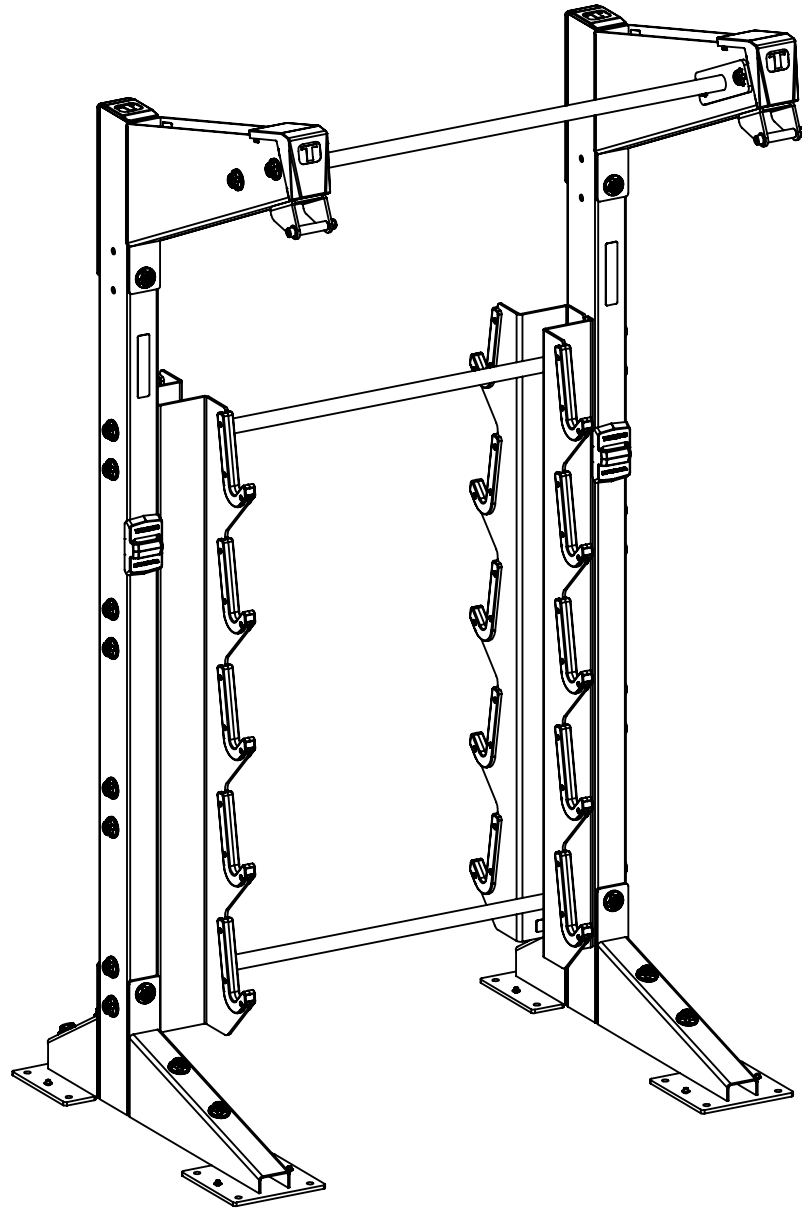

**4' 2 SIDED X 10 BARBELL STORAGE MODULE
(WITHOUT CONNECTOR)**

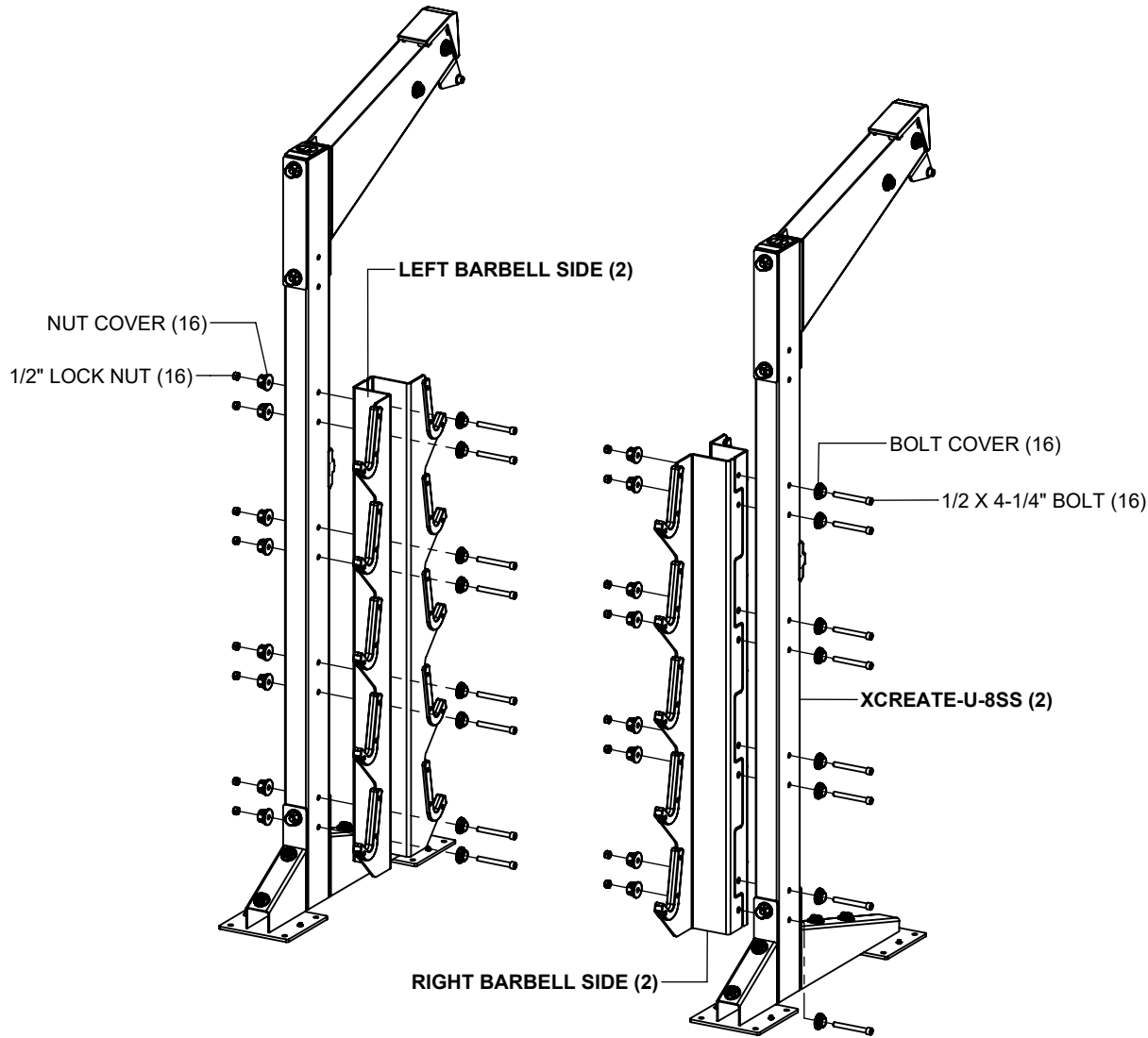

NOTES:

If more modules will be assembled, do not tighten bolts at this time.
If this is the only module being assembled, then **SECURELY** tighten all bolts in this step and previous steps.

The **XCREATE-U-7SS** is assembled the exact same way.

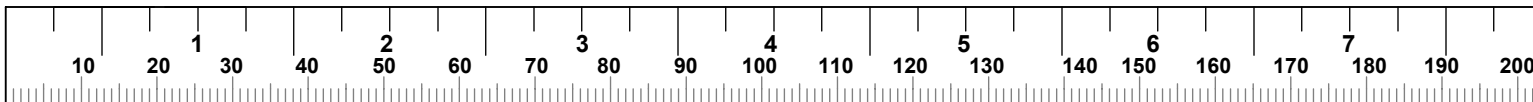

**4' 2 SIDED X 10 BARBELL STORAGE MODULE
(WITH CONNECTOR)**

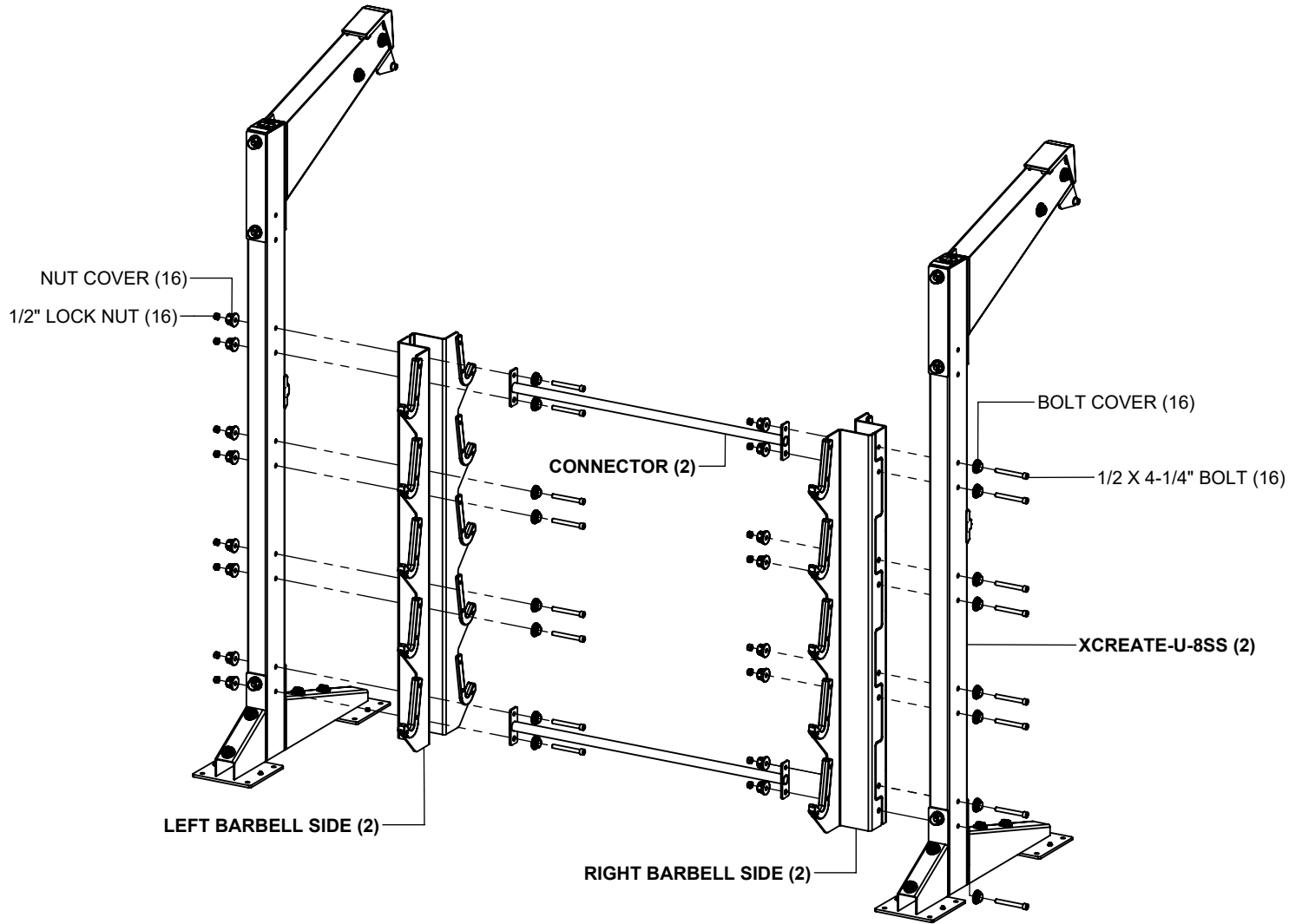

NOTES:

If more modules will be assembled, do not tighten bolts at this time.
If this is the only module being assembled, then **SECURELY** tighten all bolts in this step and previous steps.

The **XCREATE-U-7SS** is assembled the exact same way.

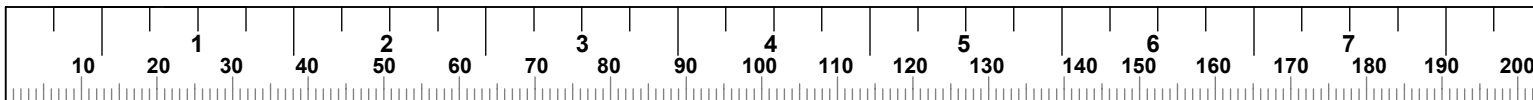

4' 2 SIDED X 10 BARBELL STORAGE MODULE

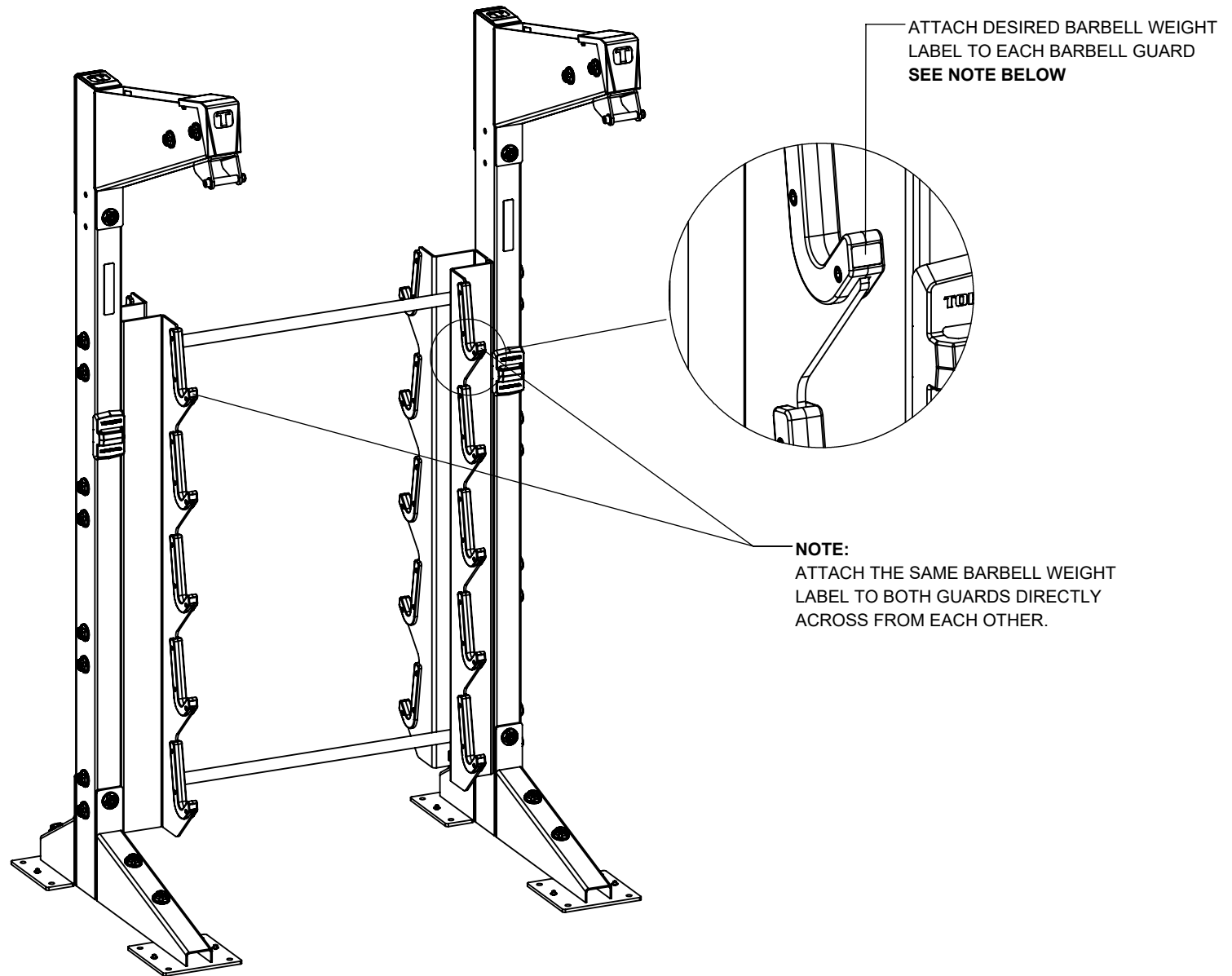

NOTE:

If you are a professional contractor installing this system for a facility, leave these labels and instruction with manager or inquire what label to attach to each barbell guard.

4' 2 SIDED X 20 BARBELL STORAGE MODULE

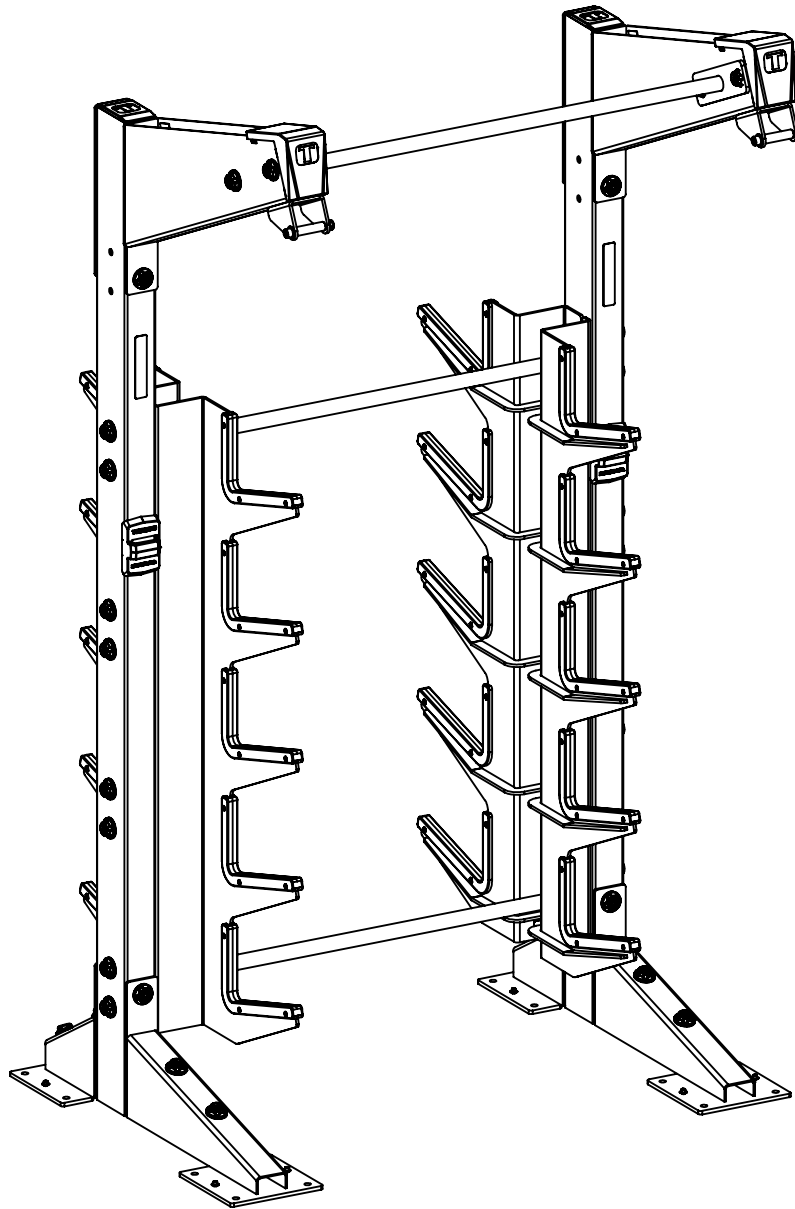

**4' 2 SIDED X 20 BARBELL STORAGE MODULE
(WITHOUT CONNECTOR)**

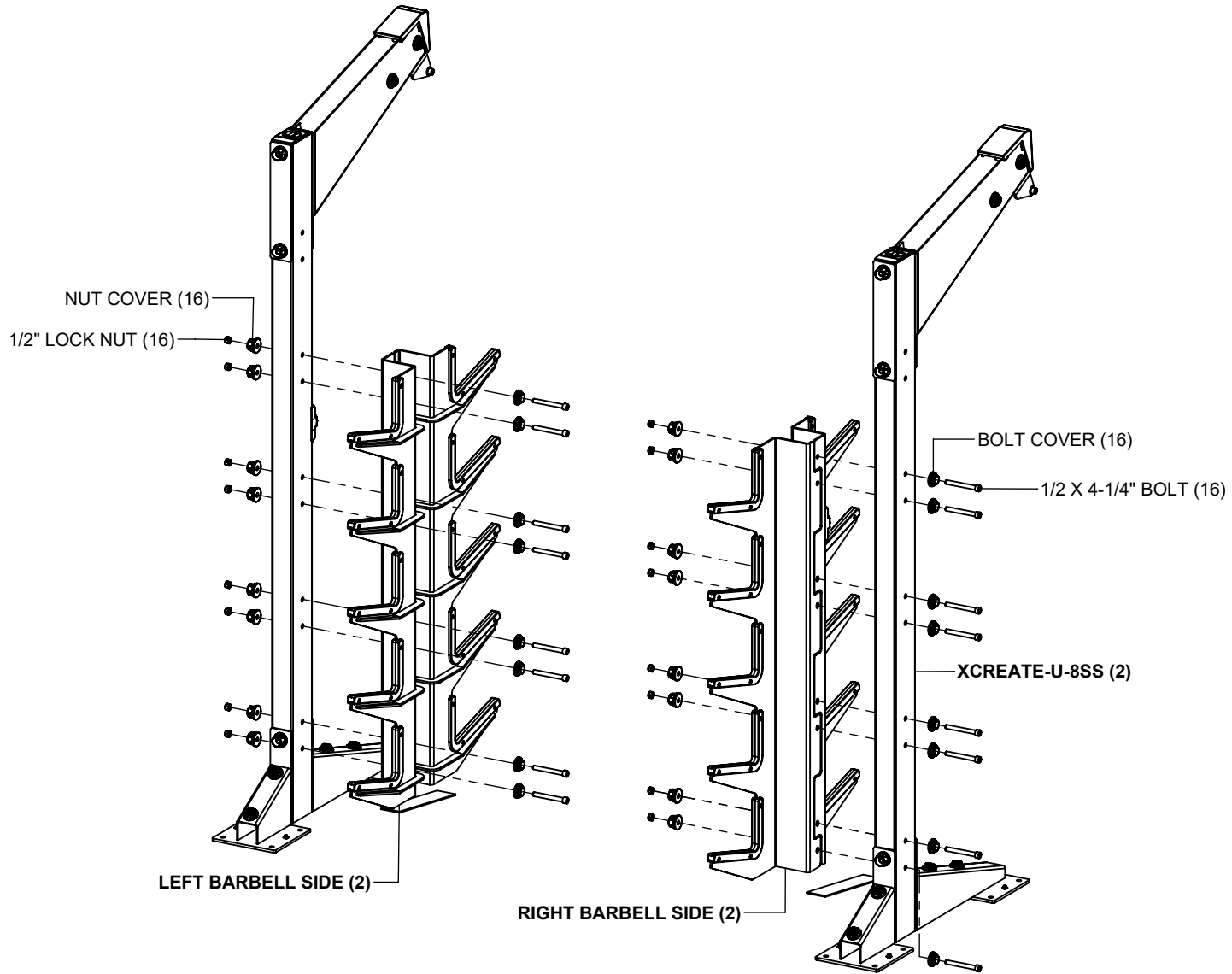

NOTES:

If more modules will be assembled, do not tighten bolts at this time.
If this is the only module being assembled, then **SECURELY** tighten all bolts in this step and previous steps.

The **XCREATE-U-7SS** is assembled the exact same way.

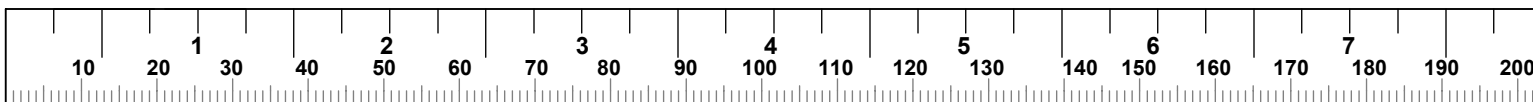

4' 2 SIDED X 20 BARBELL STORAGE MODULE (WITH CONNECTOR)

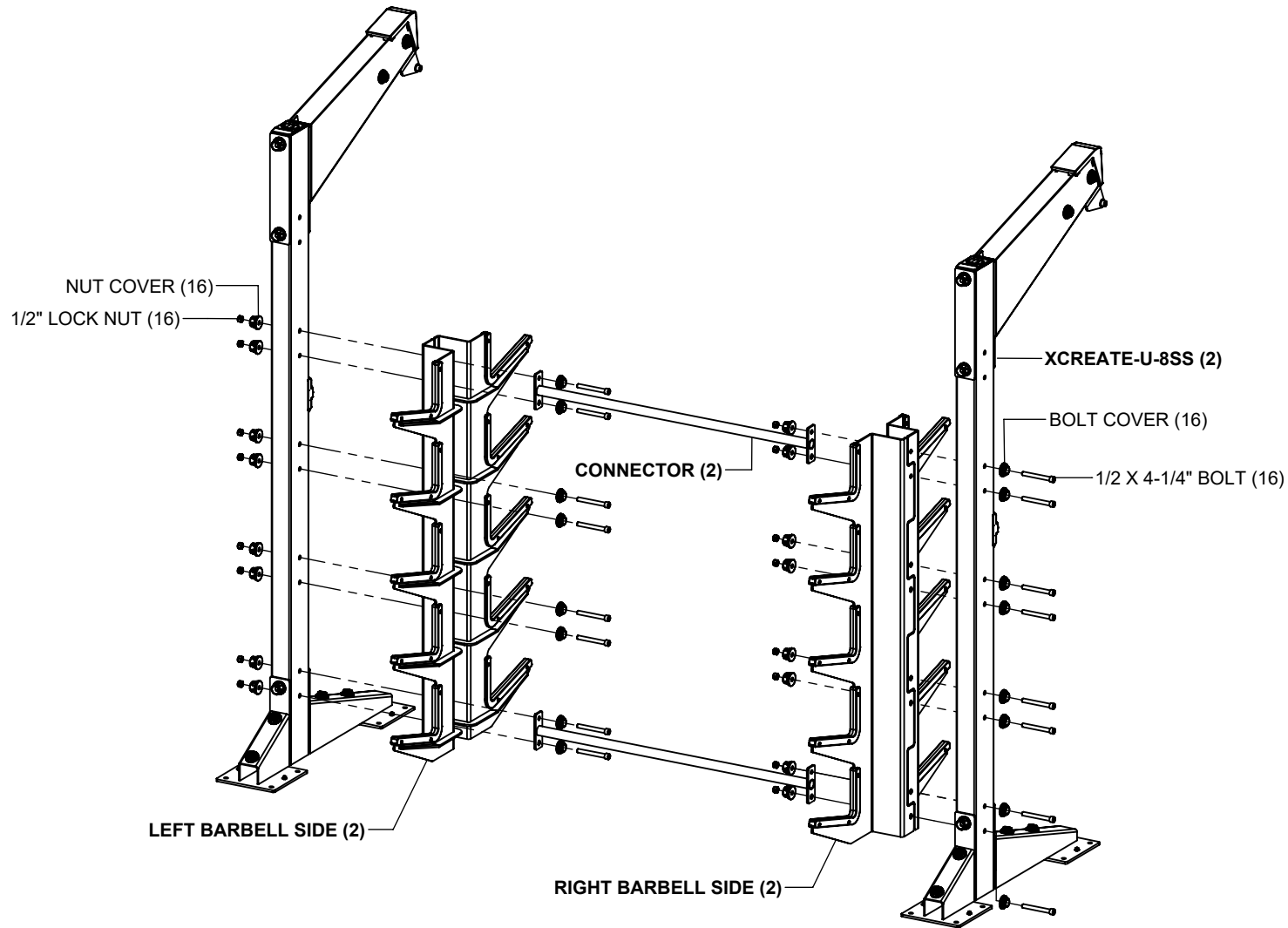

NOTES:

If more modules will be assembled, do not tighten bolts at this time.
If this is the only module being assembled, then **SECURELY** tighten all bolts in this step and previous steps.

The **XCREATE-U-7SS** is assembled the exact same way.

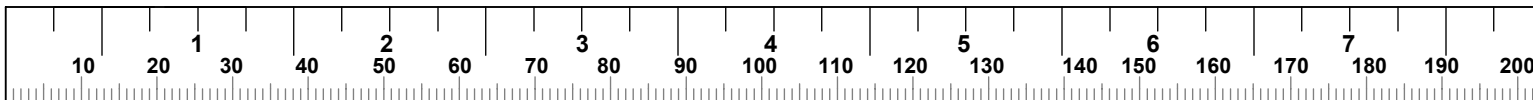

4' 2 SIDED X 10 BARBELL STORAGE MODULE

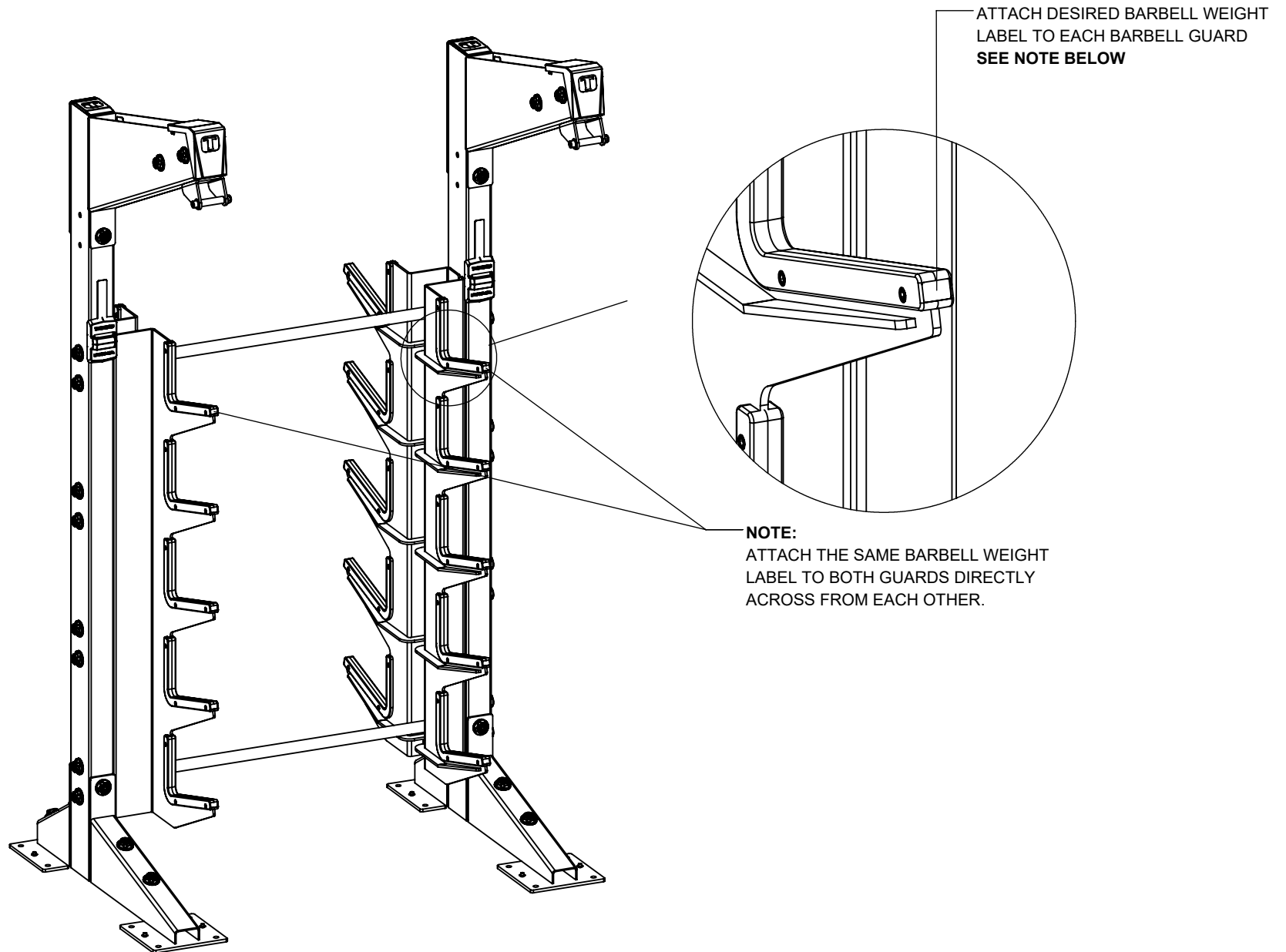

NOTE:

If you are a professional contractor installing this system for a facility, leave these labels and instruction with manager or inquire what label to attach to each barbell guard.

4' MONITOR MOUNT & STORAGE MODULE

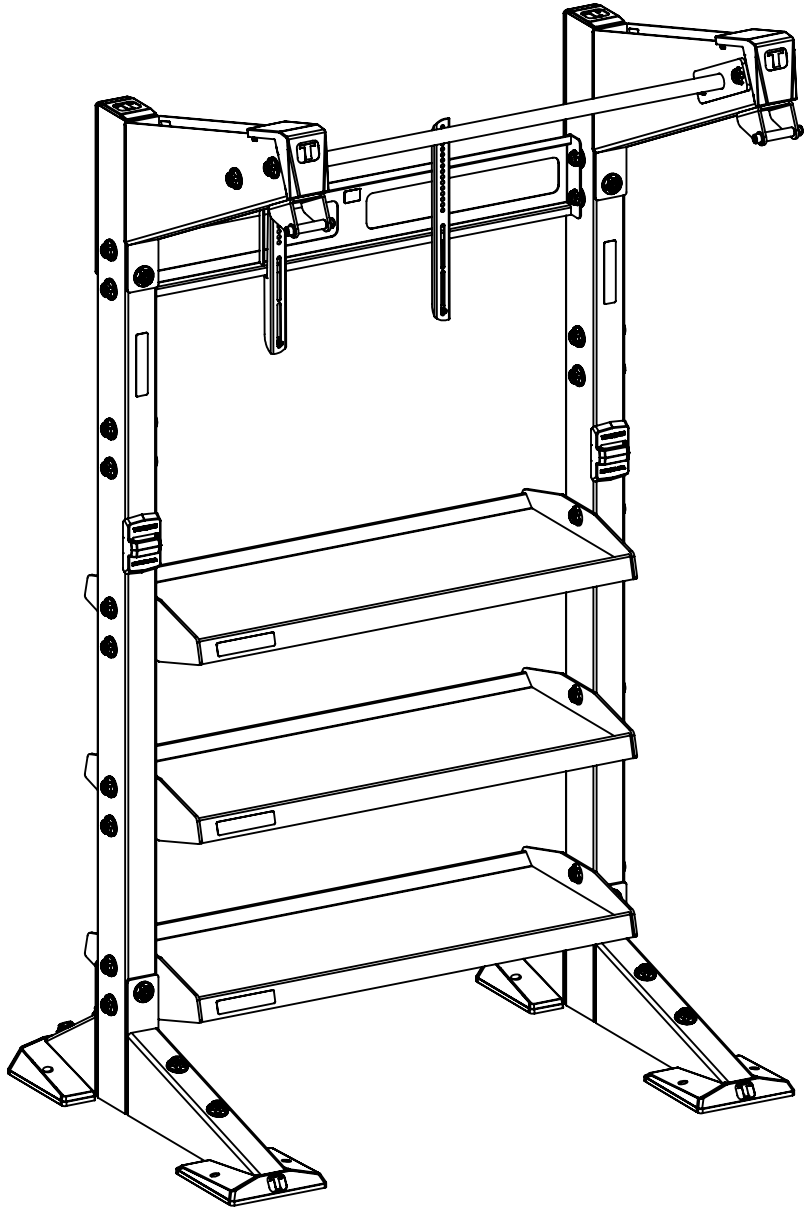

STANDARD CONFIGURATION

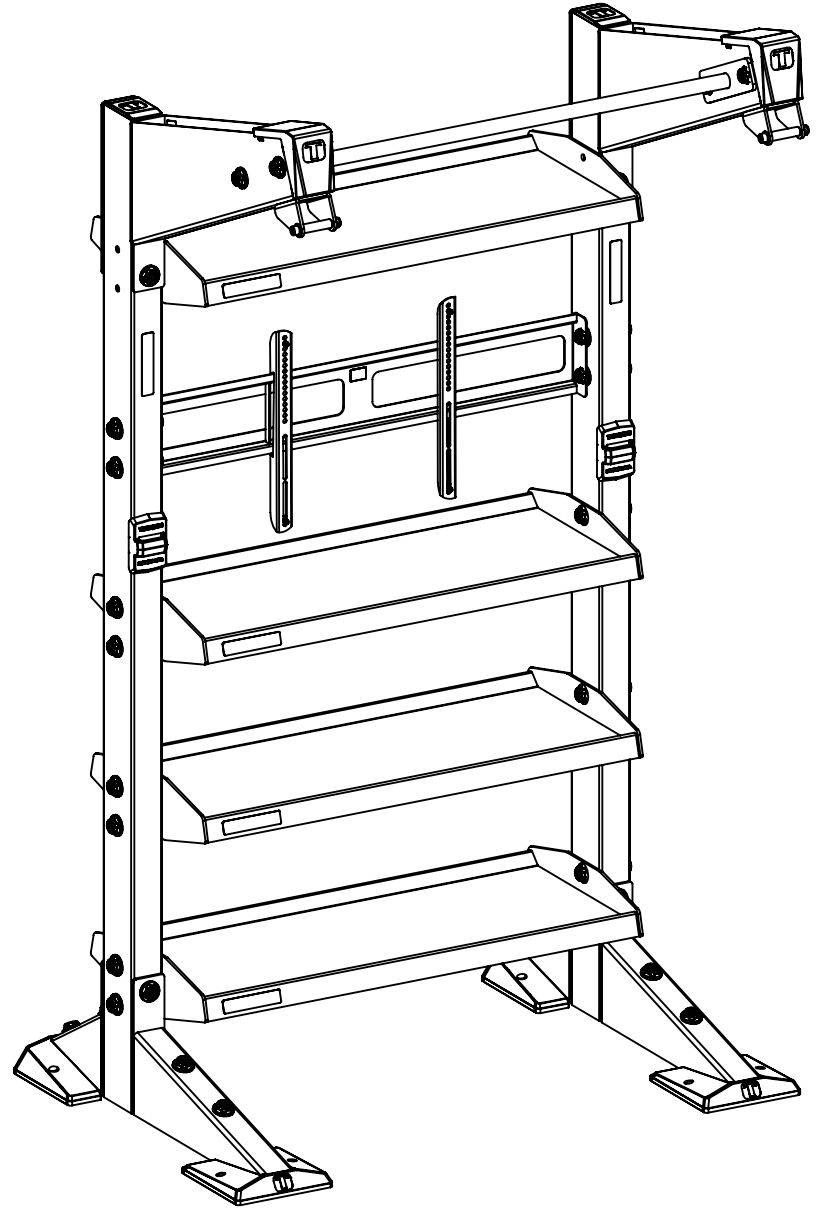

OPTIONAL CONFIGURATION

4' MONITOR MOUNT & STORAGE MODULE

STEP 1A

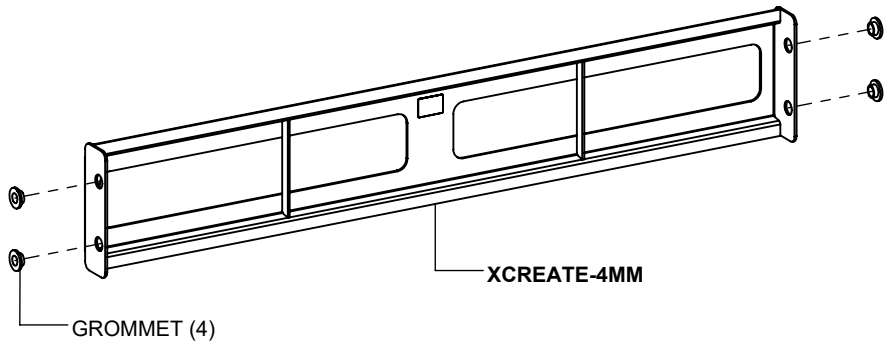

STEP 1B

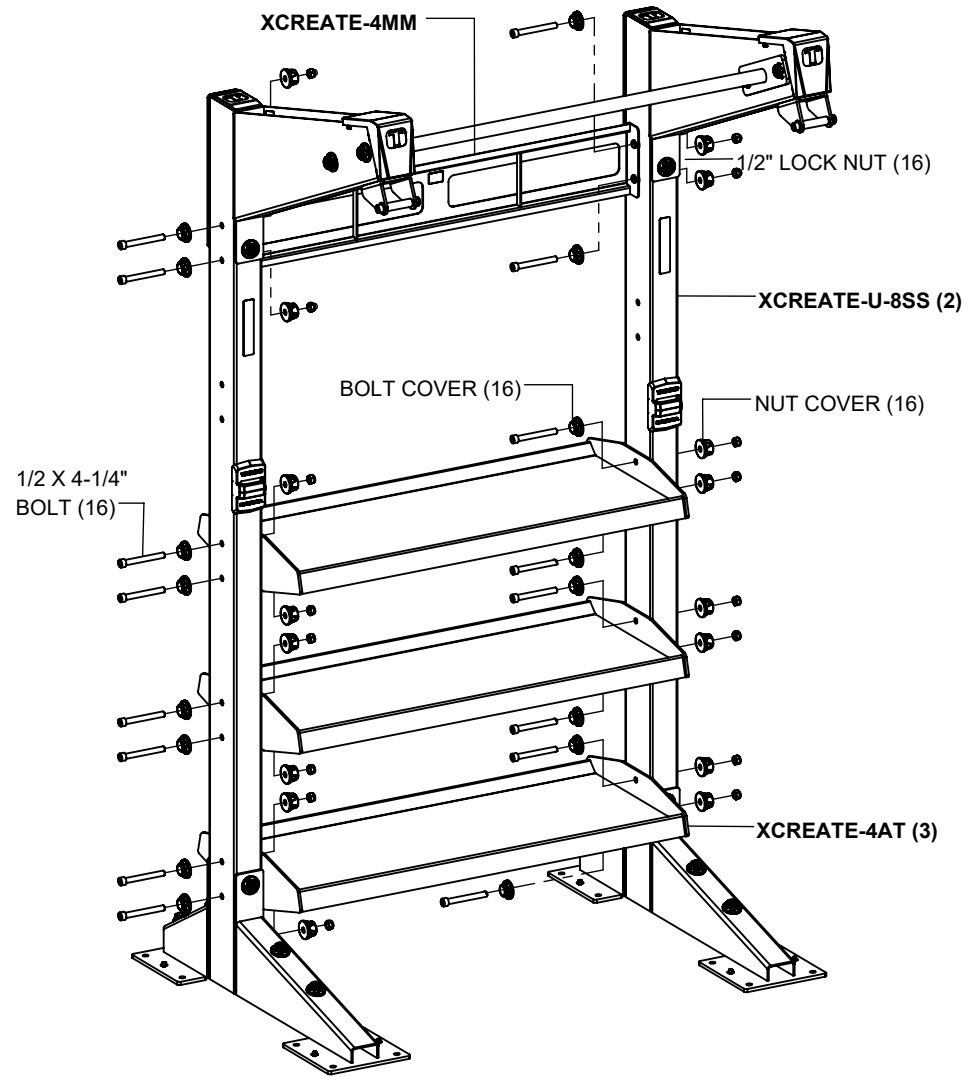

NOTES:

If more modules will be assembled, do not tighten bolts at this time. If this is the only module being assembled, then **SECURELY** tighten all bolts in this step and previous steps.

The **XCREATE-U-7SS** is assembled the exact same way.

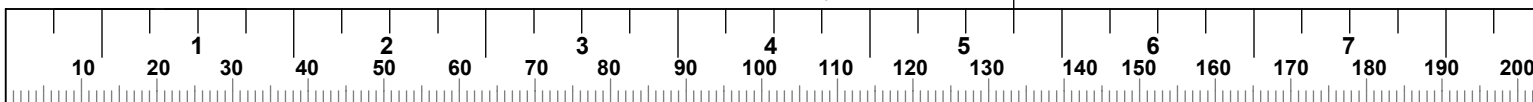

4' MONITOR MOUNT & STORAGE MODULE

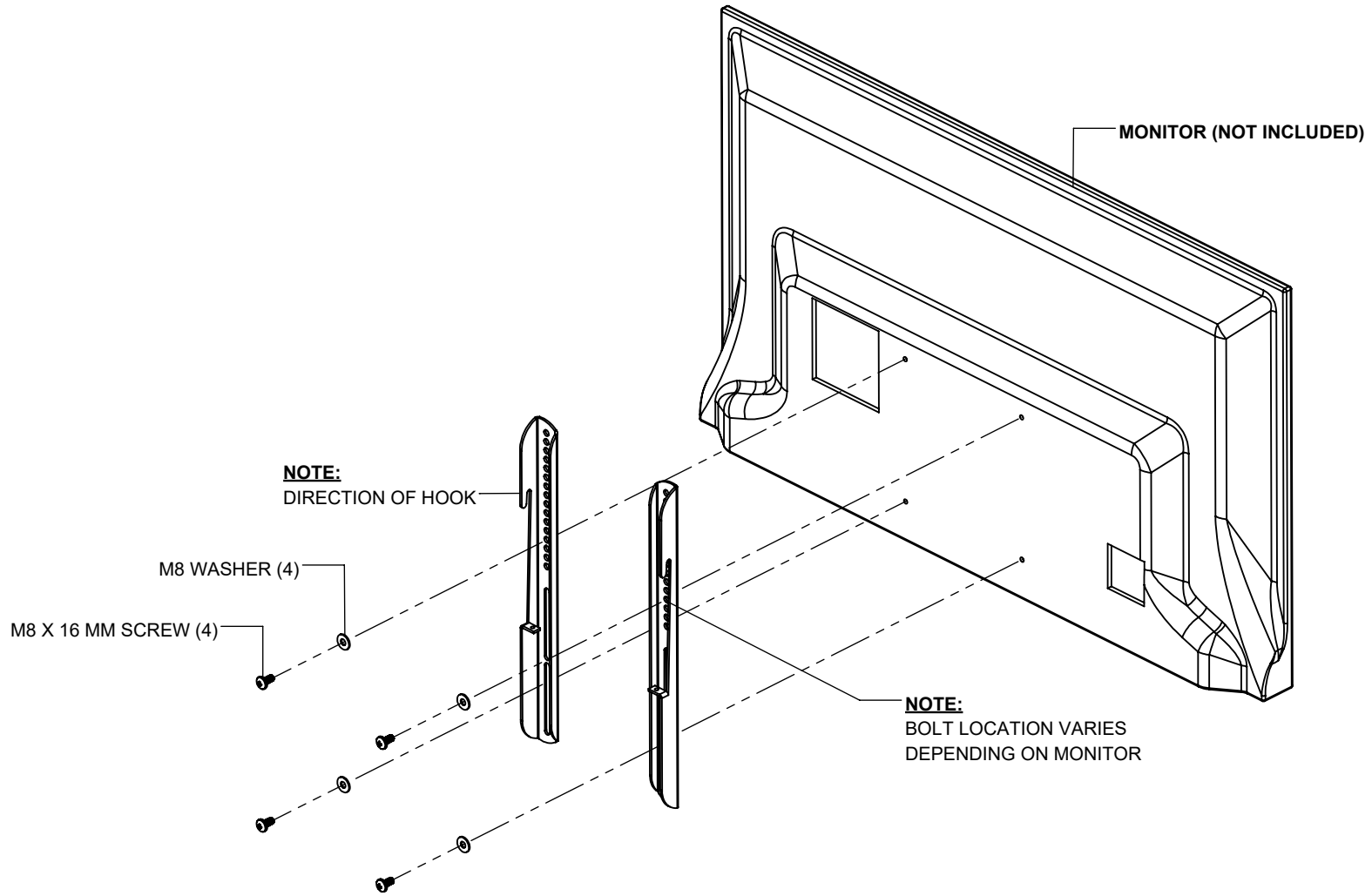

NOTE:

SECURELY tighten all connections in this step.

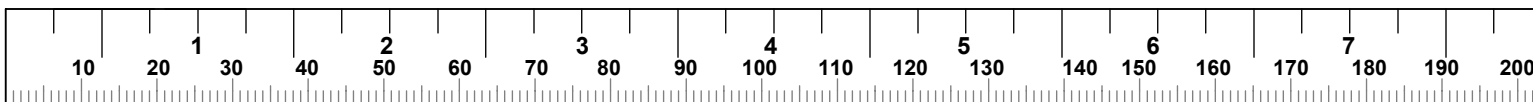

4' MONITOR MOUNT & STORAGE MODULE

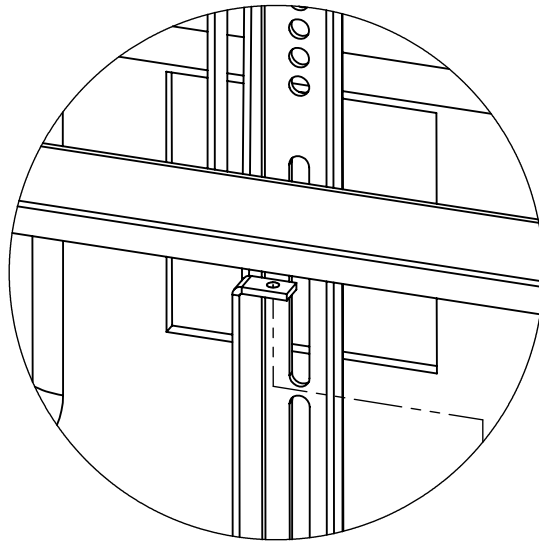

NOTE:
CENTER MONITOR BEFORE TIGHTENING

M6 x 35 MM BOLT(2)

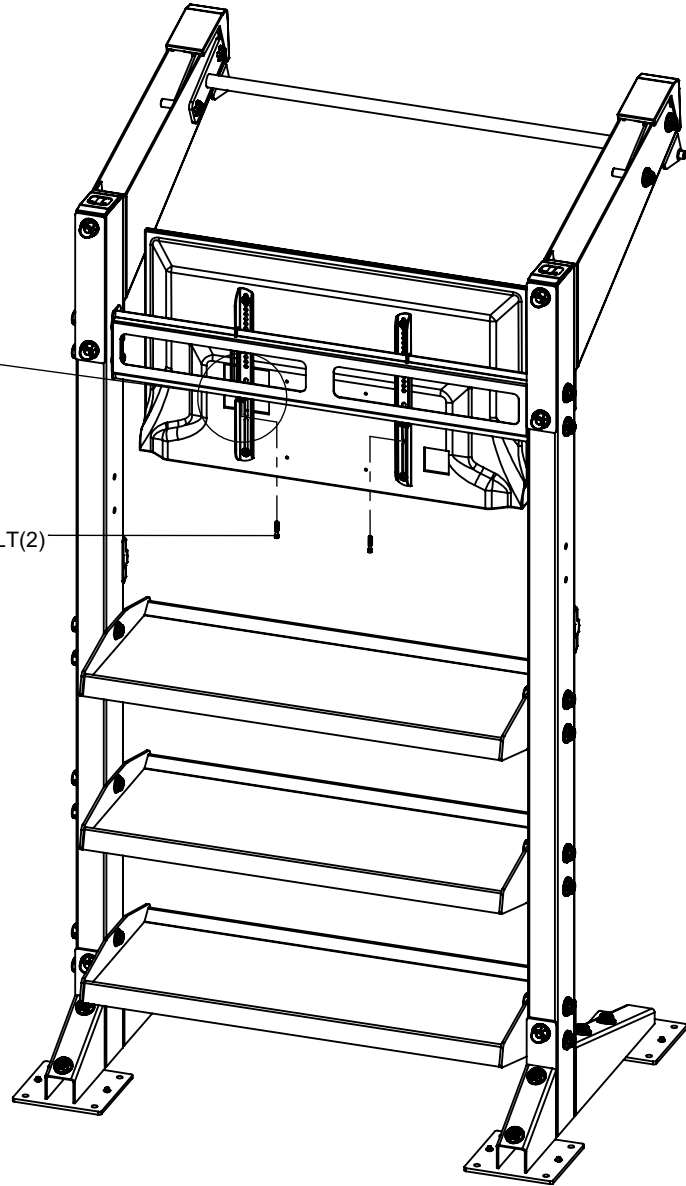

NOTE:

SECURELY tighten all connections in this step.

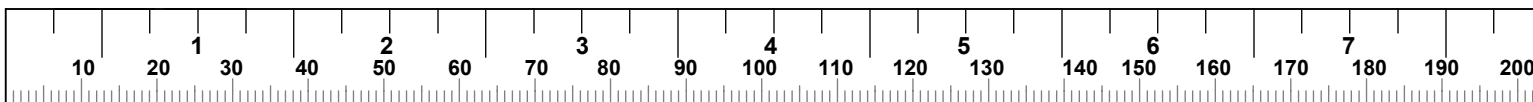

4' CUSTOM SIGN & HANGING STORAGE MODULE

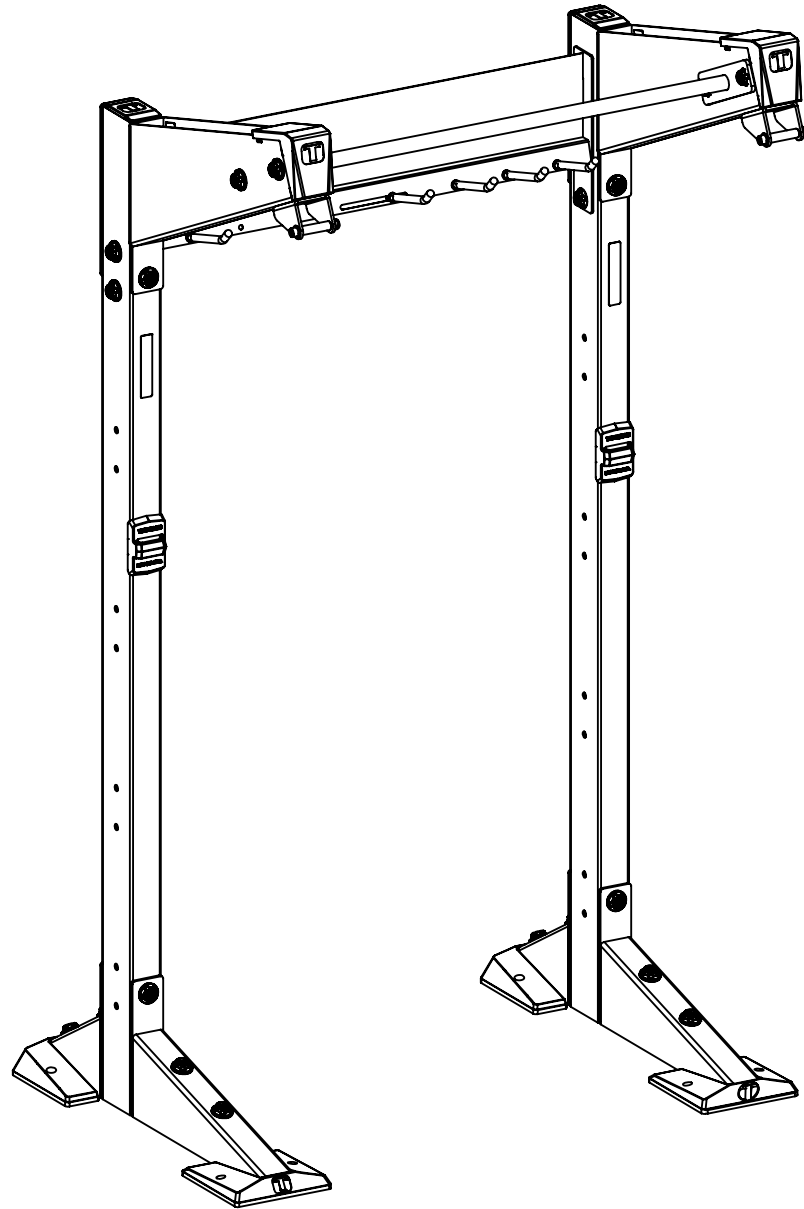

4' CUSTOM SIGN & HANGING STORAGE MODULE

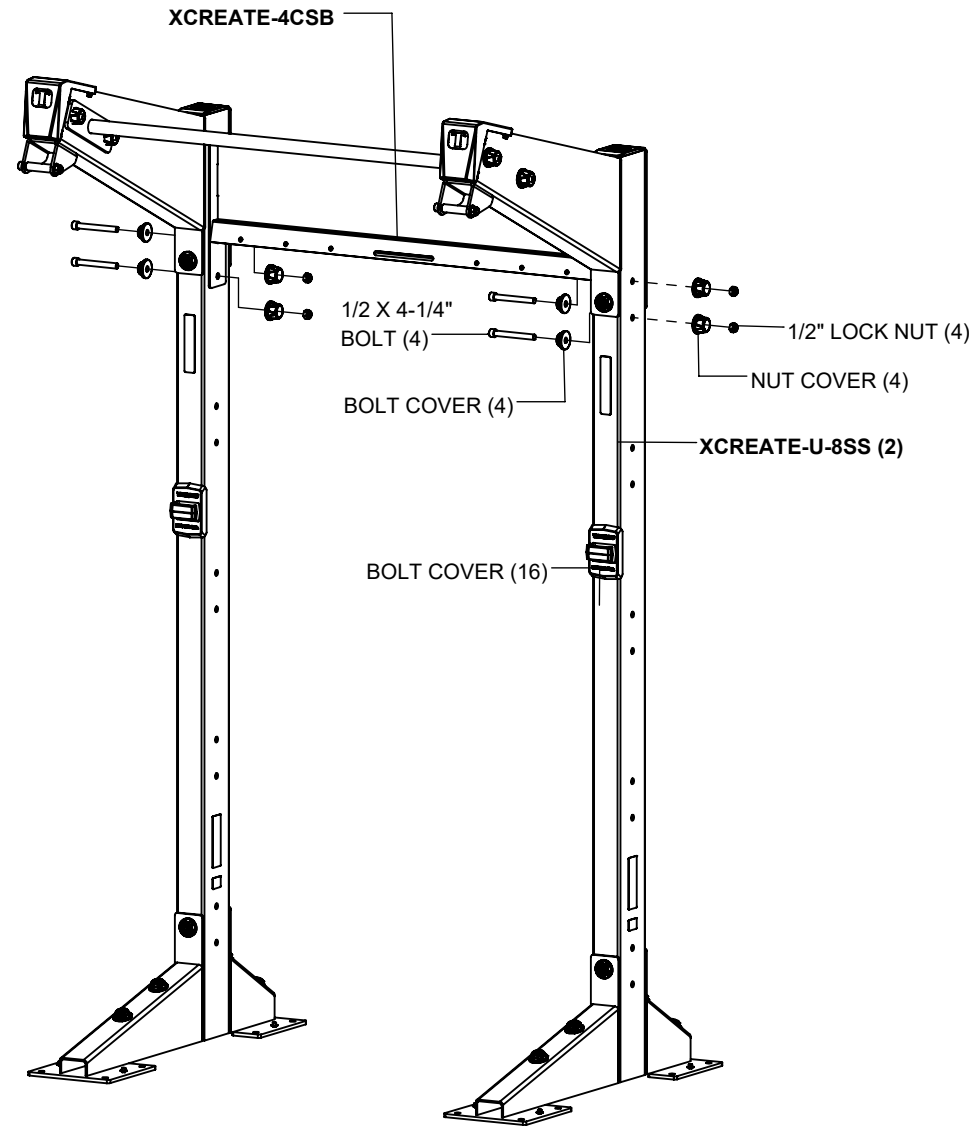

NOTES:

If more modules will be assembled, do not tighten bolts at this time.
If this is the only module being assembled, then **SECURELY** tighten all bolts in this step and previous steps.

The **XCREATE-U-7SS** is assembled the exact same way.

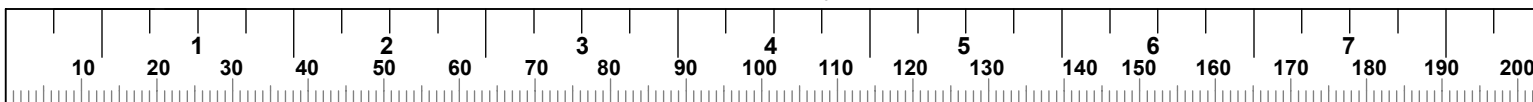

2.5' BALL AND HANGING STORAGE MODULE

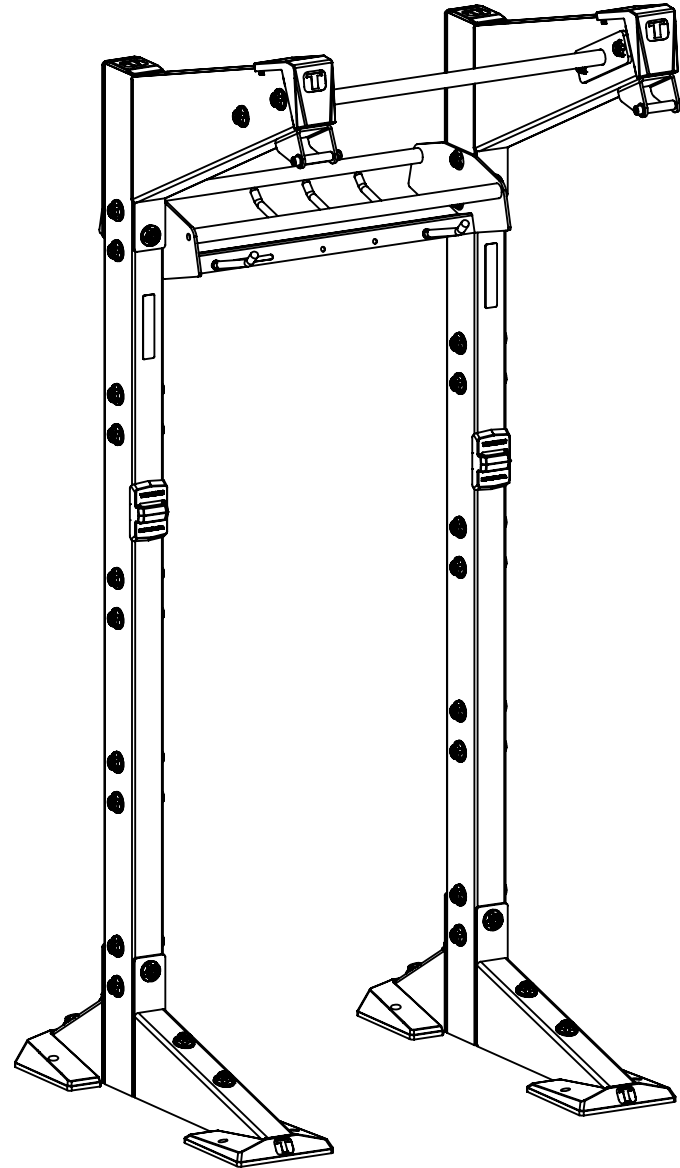

2.5' BALL AND HANGING STORAGE MODULE

NOTE:

MAKE SURE TO USE PRE-INSTALLED SPACERS (2)

NOTE:

REMOVE END CAP PRIOR TO ASSEMBLY.
RE-ATTACH END CAP AFTER ASSEMBLY (2)

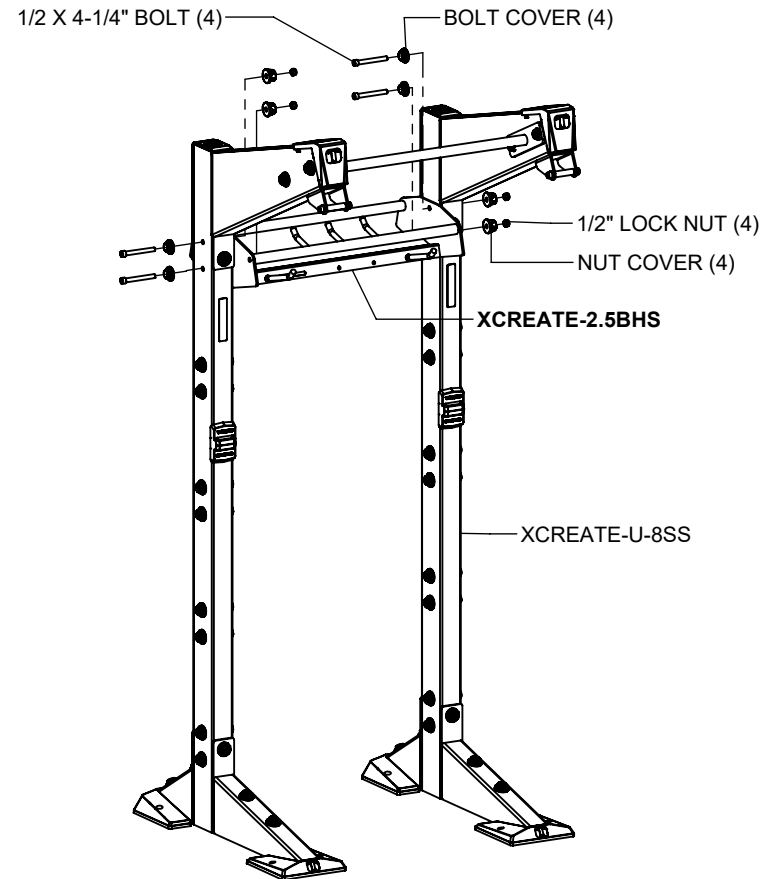
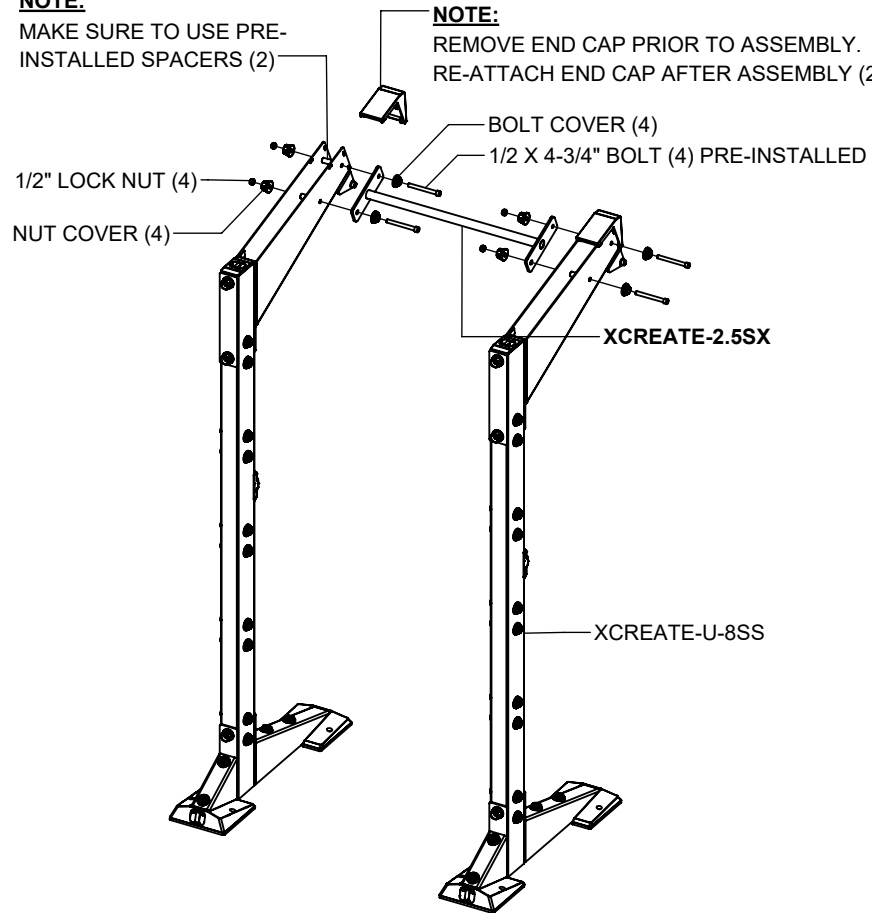

NOTES:

If more modules will be assembled, do not tighten bolts at this time.
If this is the only module being assembled, then **SECURELY** tighten all bolts in this step and previous steps.

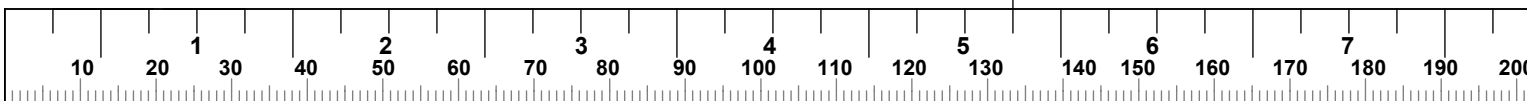

6' RECTANGULAR CROSS MODULE

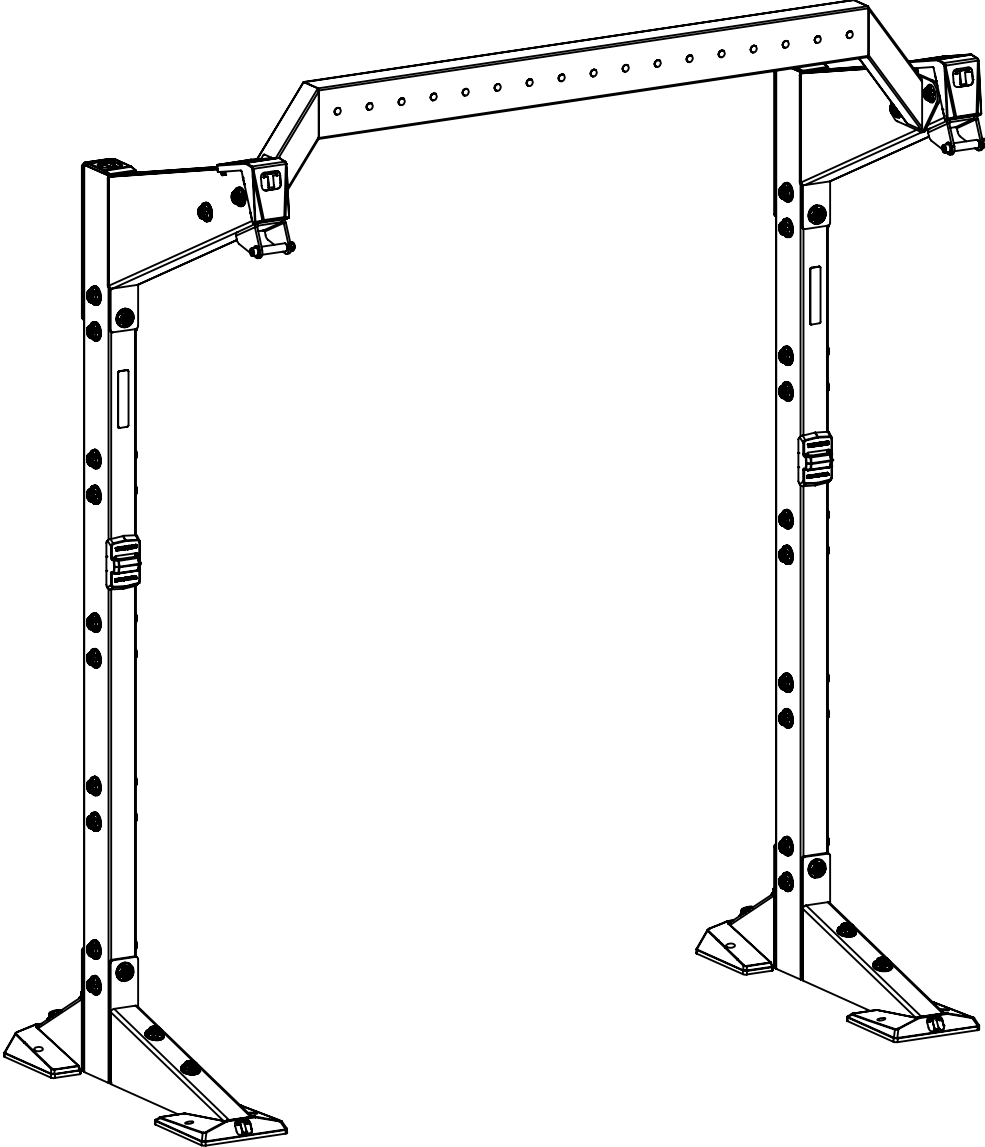

6' RECTANGULAR CROSS MODULE

NOTE:
REMOVE END CAP PRIOR TO ASSEMBLY.
RE-ATTACH END CAP AFTER ASSEMBLY (2)

NOTE:
MAKE SURE TO USE PRE-INSTALLED SPACERS (2)

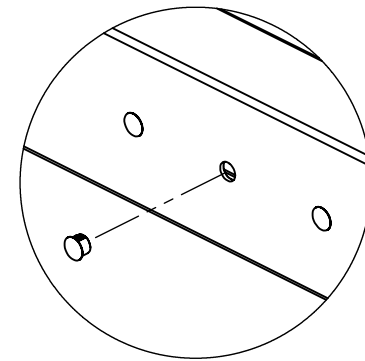
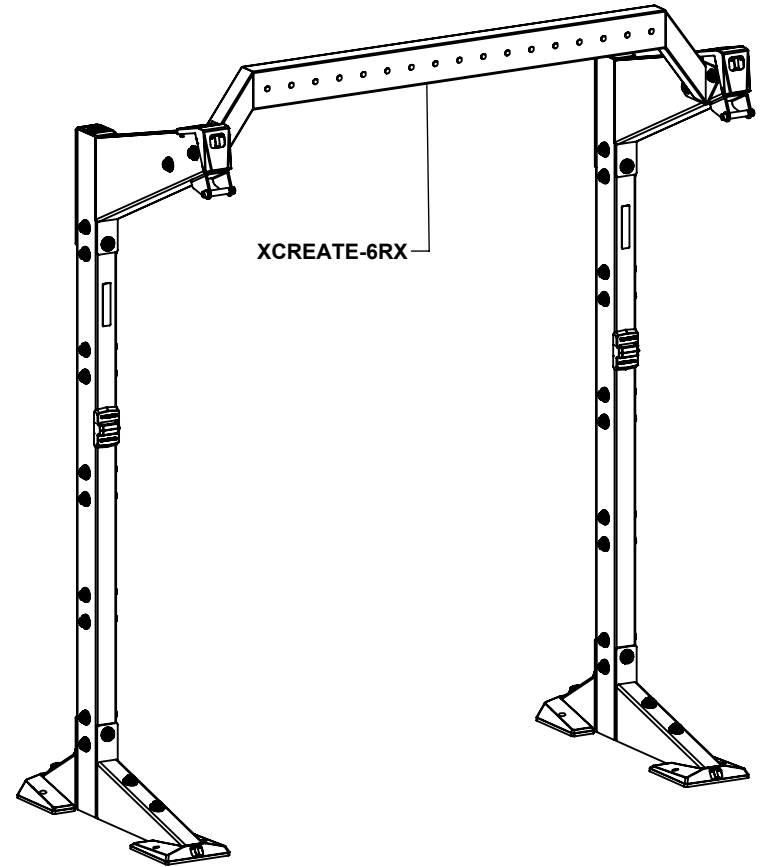
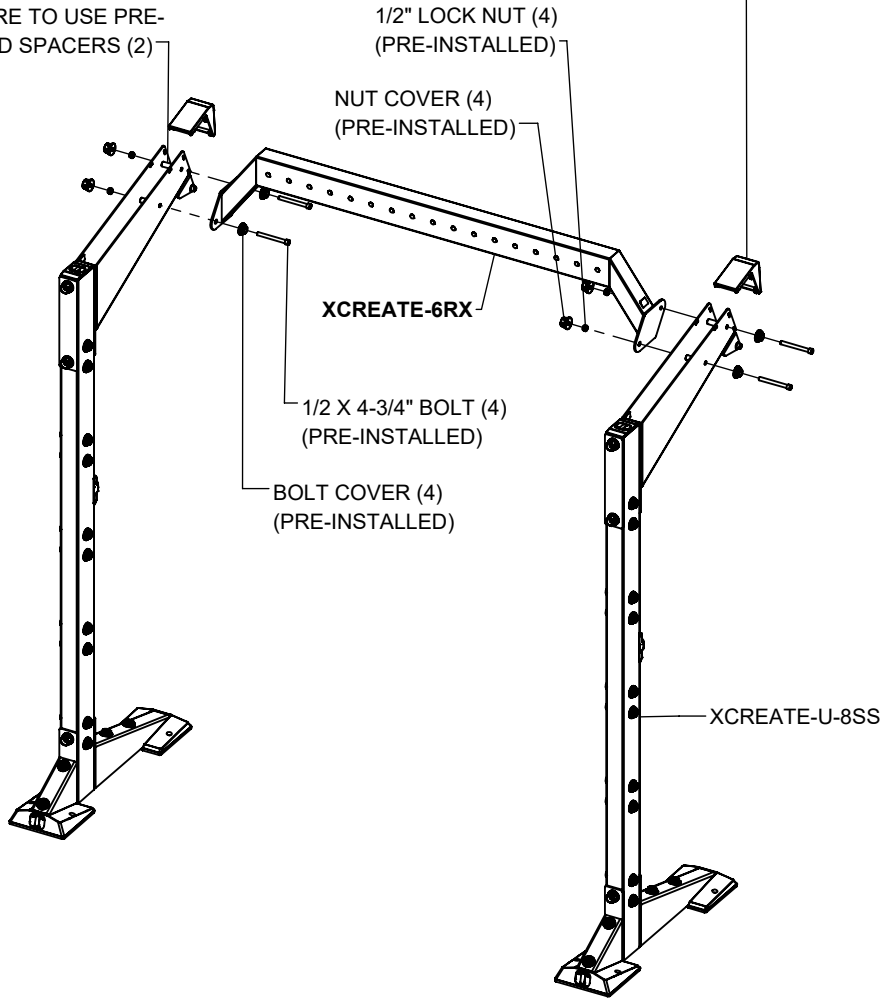

NOTE:
AFTER ALL ATTACHMENTS HAVE BEEN ASSEMBLED (SEE ATTACHMENT SECTION), COVER ALL EMPTY HOLES WITH THE COVER CAPS PROVIDED.

NOTES:

If more modules will be assembled, do not tighten bolts at this time. If this is the only module being assembled, then **SECURELY** tighten all bolts in this step and previous steps.

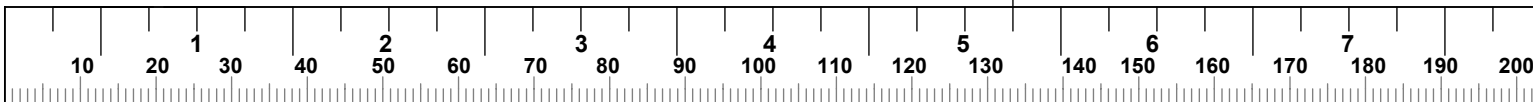

4' HEAVY BAG MODULE

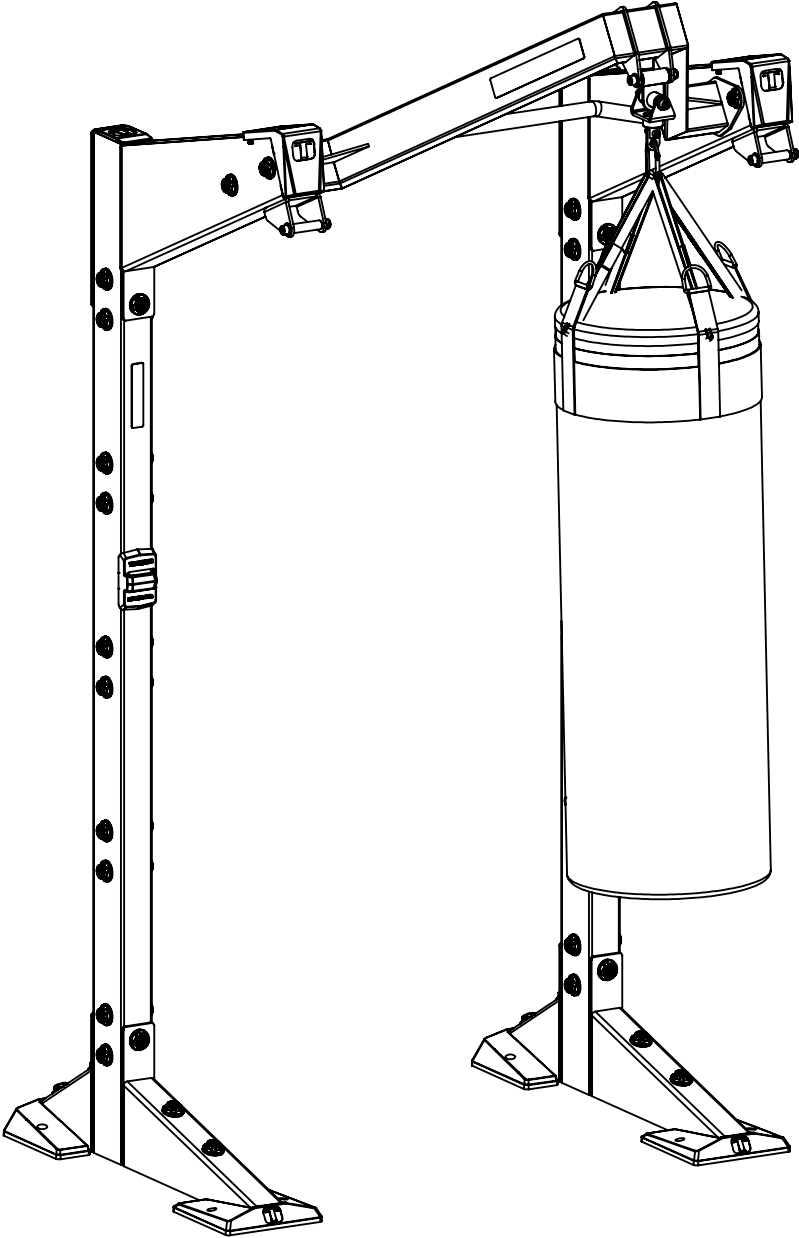

4' HEAVY BAG MODULE

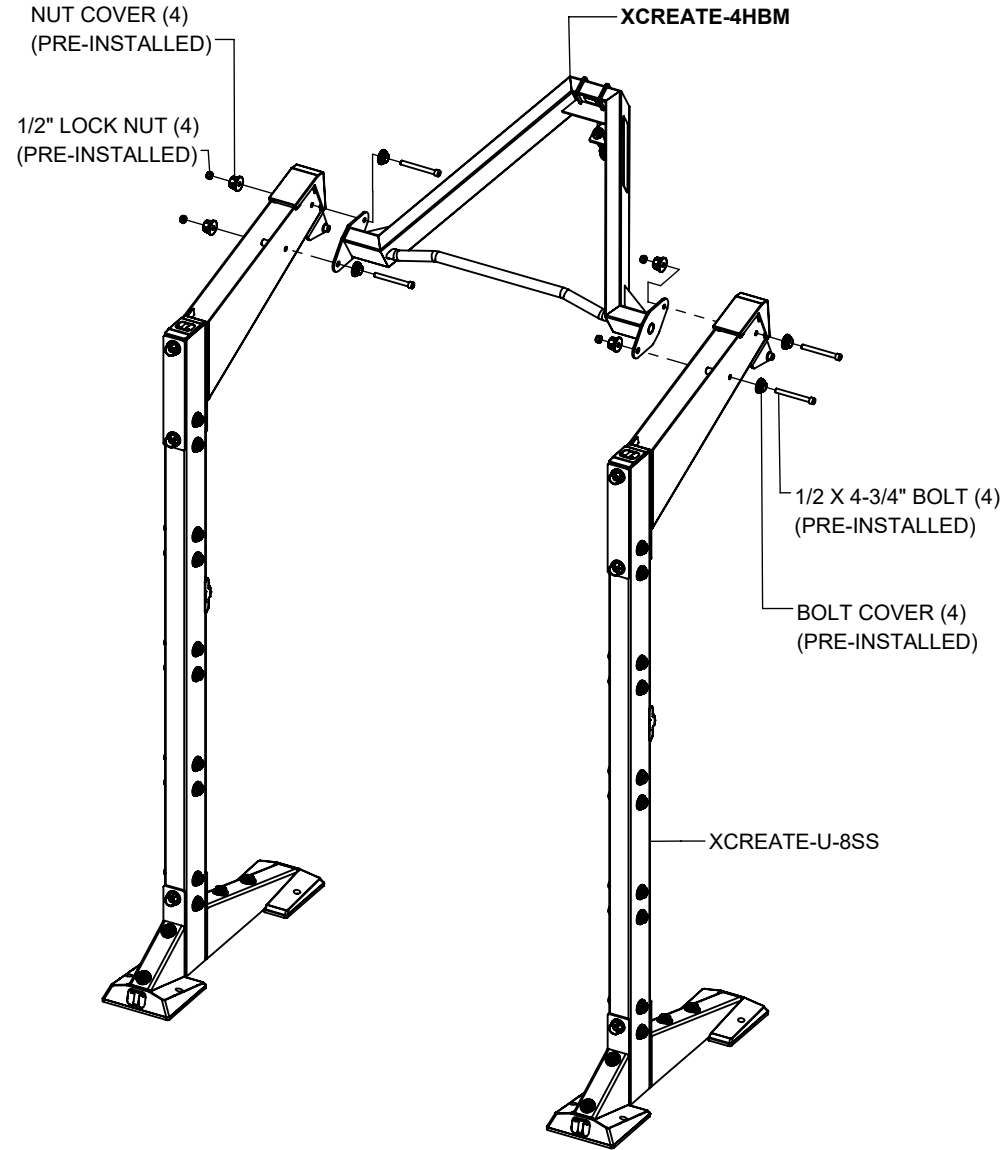
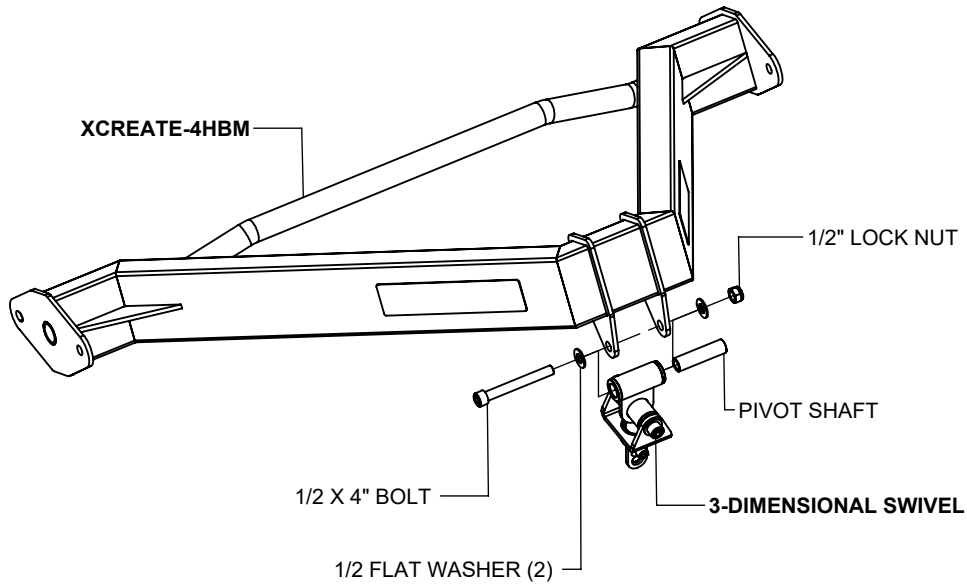

NOTES:

SECURELY tighten all bolt connections in this step.

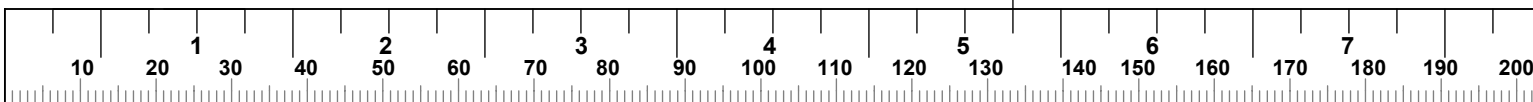

MAT STORAGE AND ACCESSORY PINS

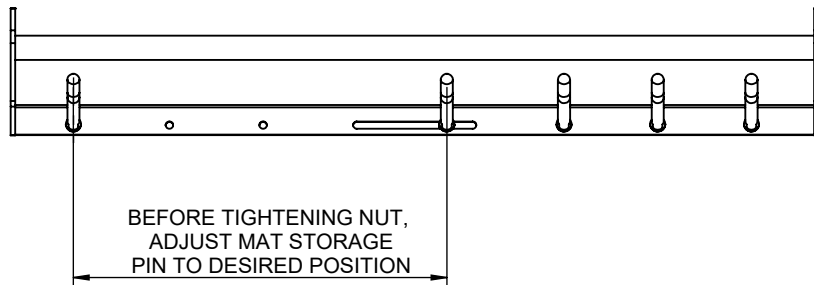
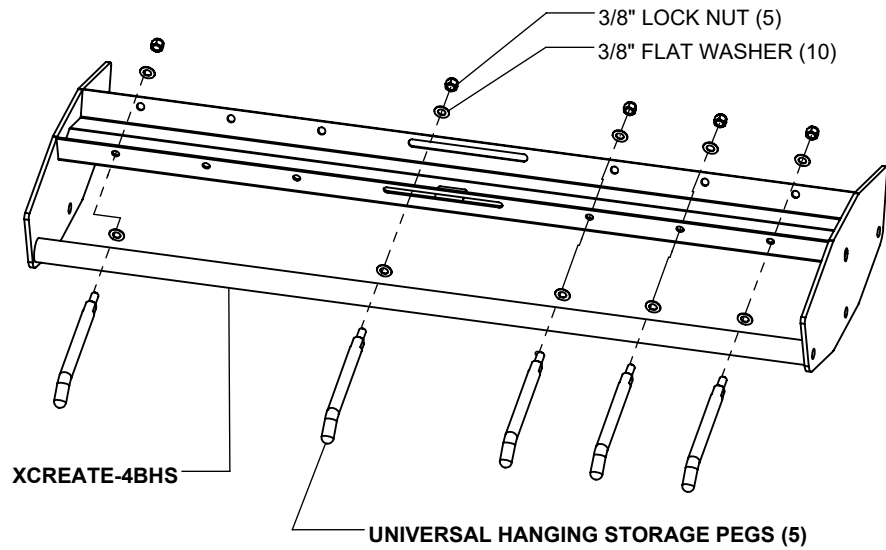

NOTE:

For the purpose of illustration the XCREATE-4BHS is shown. The XCREATE-4BHS, XCREATE-4CSB and XCREATE-6BHS can be assembled the same way.

SECURELY tighten all connections in this step.

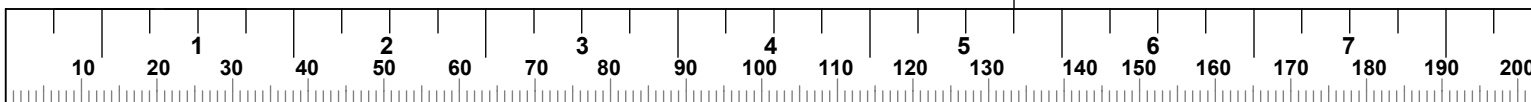
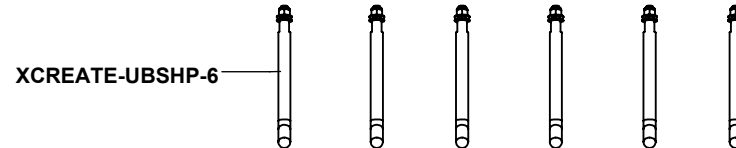
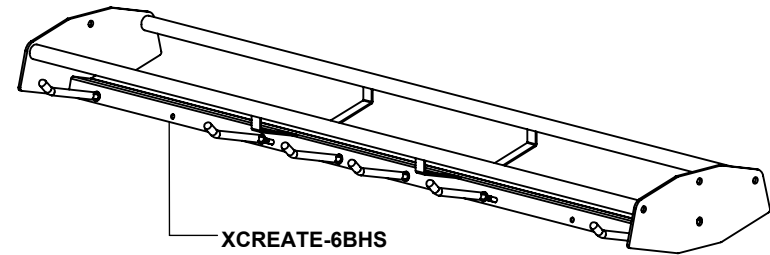
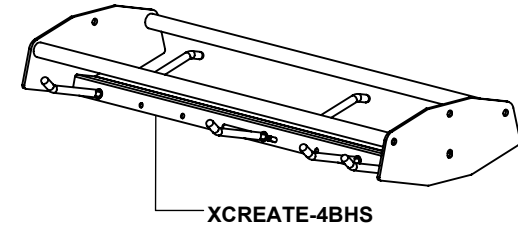
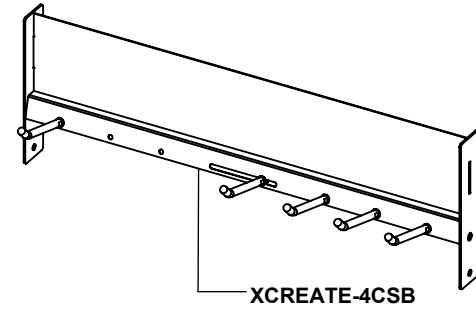

ACCESSORY TRAY LABELS

ATTACH DESIRED
LABEL TO EACH
ACCESSORY TRAY
SEE NOTE BELOW

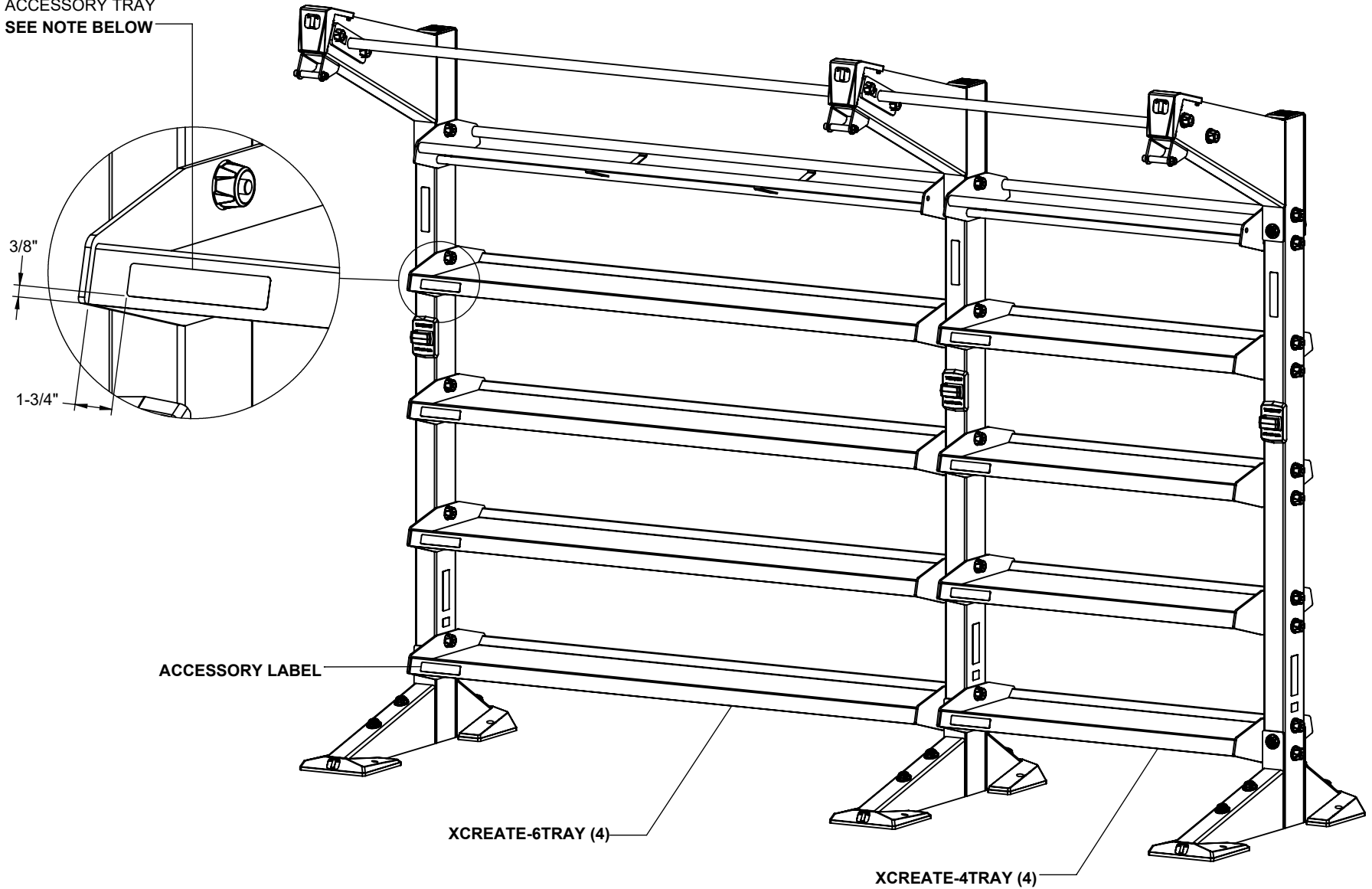

NOTE:

If you are a professional contractor installing this system for a facility, leave these labels and instruction with manager or inquire what label to attach to each accessory tray.

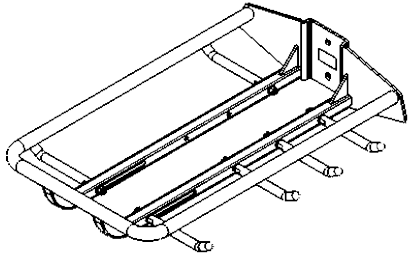

XCREATE-BHSE
BALL AND HANGING
STORAGE EXTENSION

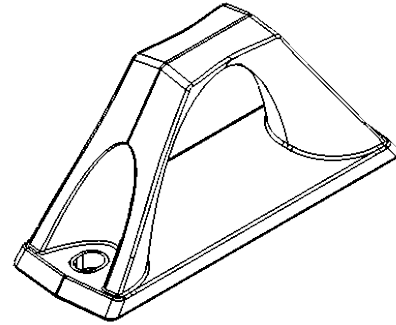

XRACK-BRA
BATTLE ROPE ANCHOR

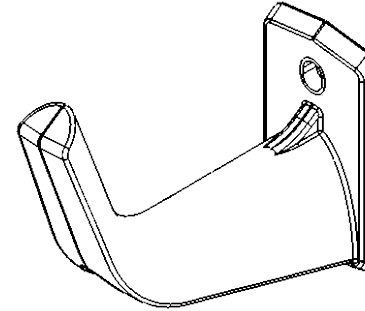

XCREATE-HSH
HANGING STORAGE HOOK

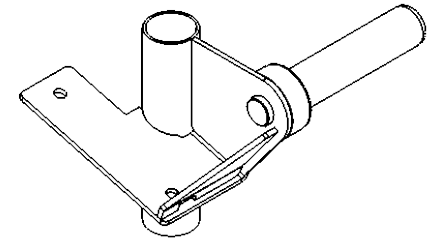

XCREATE-DP
DOUBLE PLAY

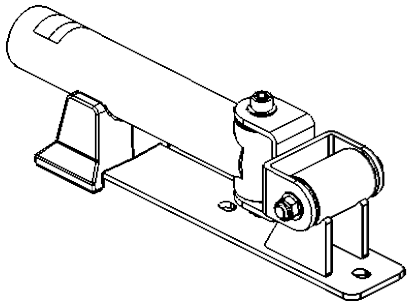

XHMGRT
HORIZONTAL MOUNT
GROUND ROTATIONAL TRAINER

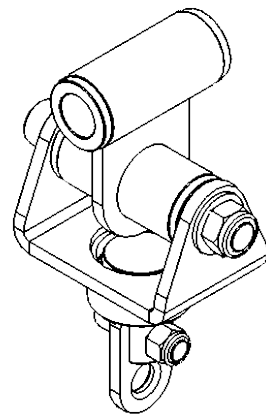

XCREATE-3DS
3 DIMENSIONAL SWIVEL

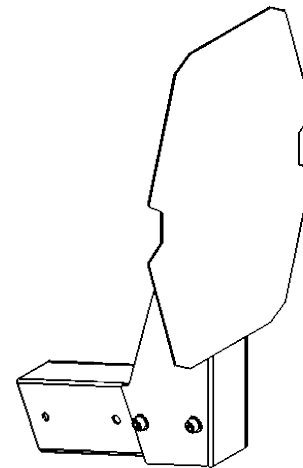

XCREATE-BT
BALL TARGET

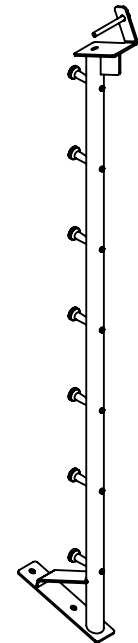

XCREATE-RBA
RESISTANCE BAND ANCHOR

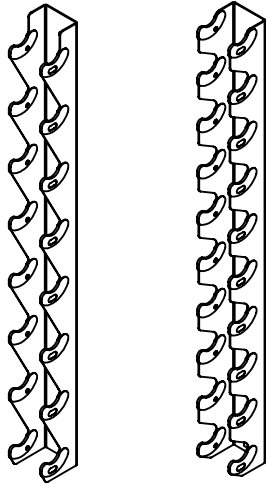

XCREATE-VDS4 / VDS5
VERTICAL DUMBBELL
STORAGE

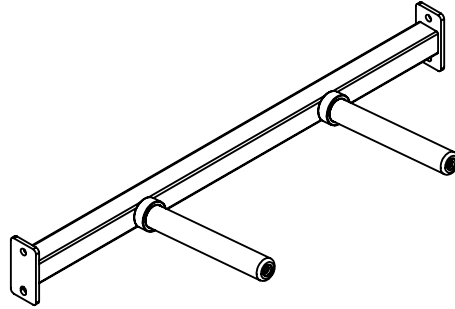

XCREATE-4SSHWS
4' SINGLE SIDE HORIZONTAL
WEIGHT STORAGE

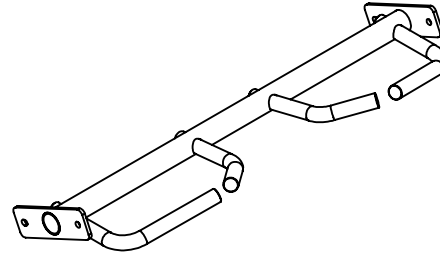

XCREATE-4MGX
4' MULTI GRIP CROSS

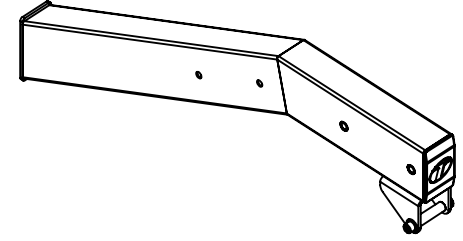

XCREATE-TBE
TOP BOOM EXTENSION

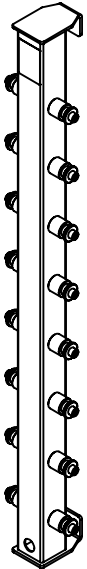

XCREATE-AA
ATTACHMENT ANCHOR

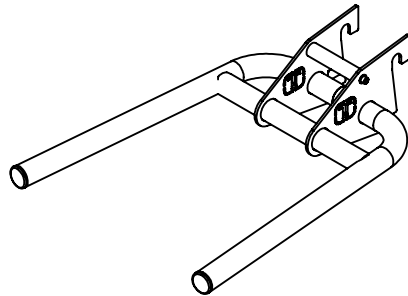

XCREATE-AAD
DIP ATTACHMENT

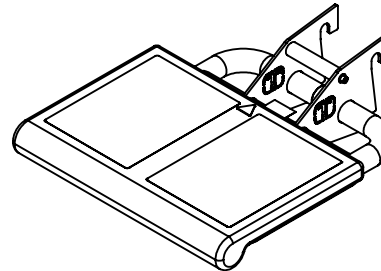

XCREATE-AAPS
PLYO STEP

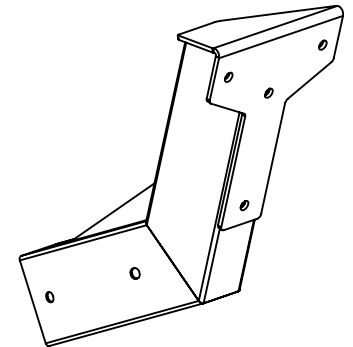

XCREATE-AE
ATTACHMENT EXTENSION

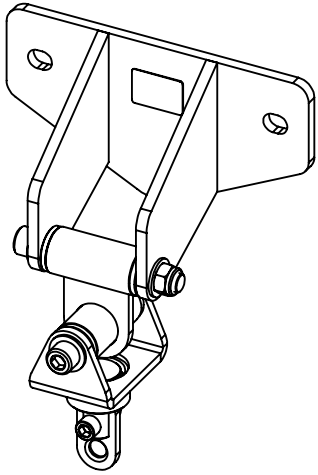

XCREATE-3DSM
3 DIMENSIONAL SWIVEL W/MOUNT

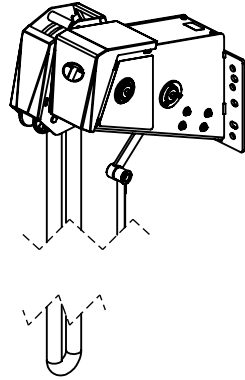

XERT
RELENTLESS ROPE TRAINER

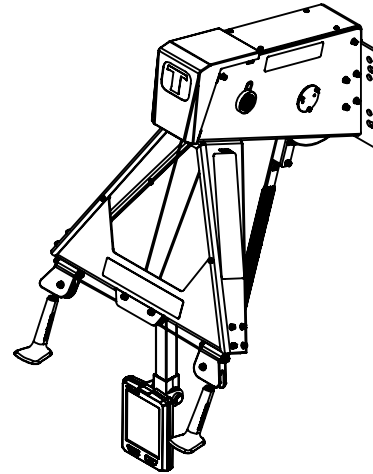

XRR-SKI
RELENTLESS RIPPER

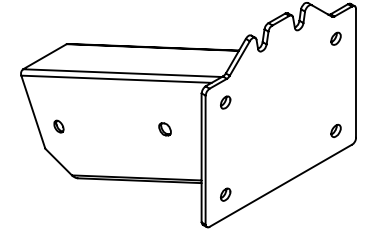

XCREATE-BMXERT
BOOM MOUNT

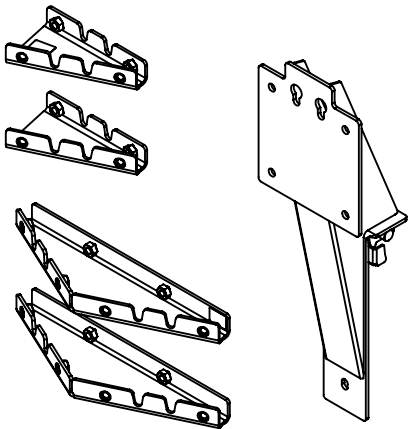

XCREATE-SAM
SIDE ATTACHMENT MOUNT

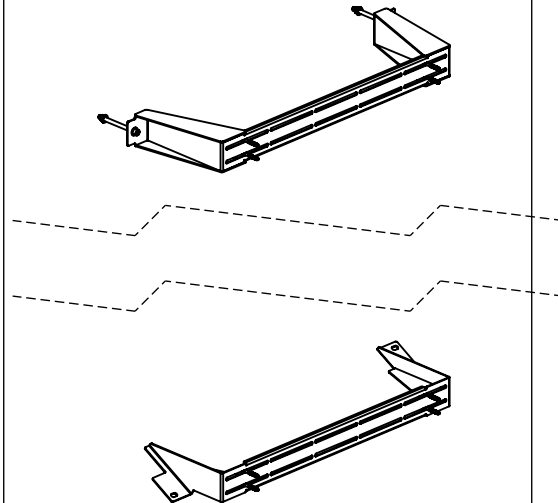

XCREATE-4WAB
4' WALL ANCHOR BRACKET

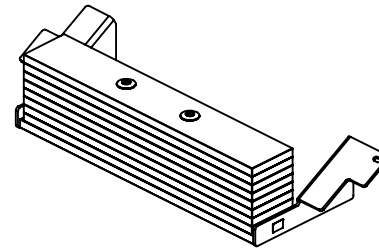

XCREATE-4CWS/CWP
4' COUNTERWEIGHT SUPPORT/
COUNTERWEIGHT PLATES

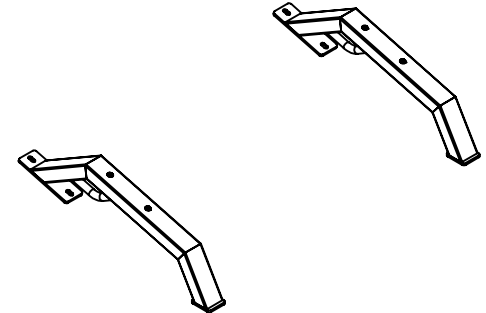

XCREATE-OR
OUTRIGGER

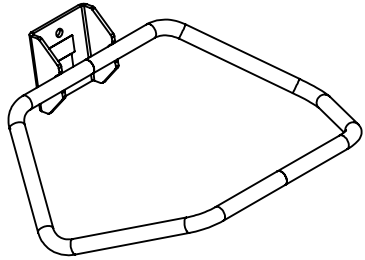

XCREATE-SA-BOSU
BOSU STORAGE ATTACHMENT

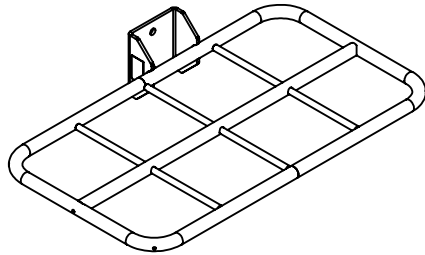

XCREATE-FRS
FOAM ROLLER STORAGE

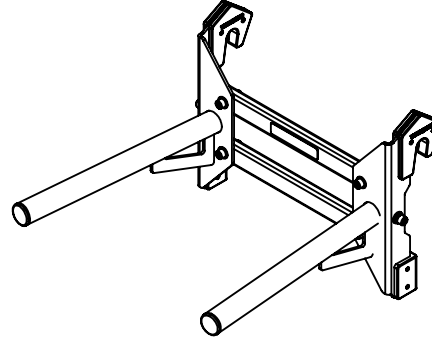

XCREATE-SBDA
STALL BAR DIP ATTACHMENT

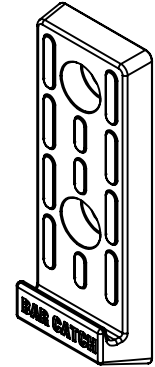

BCSA
BAR CATCH STORAGE
ATTACHMENT

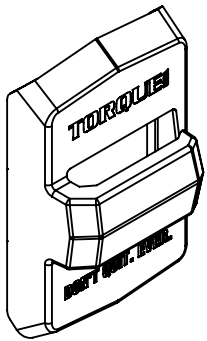

XCREATE-HMSC
SUSPENSION CLIP

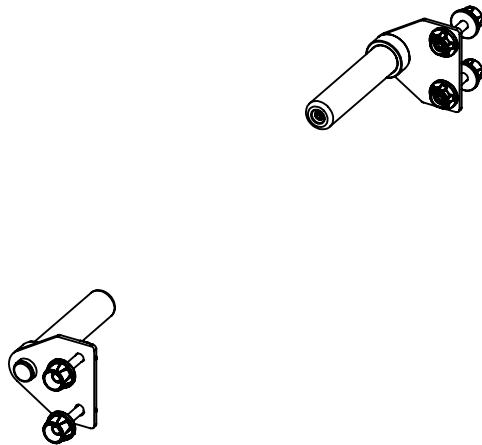

CPWH
CHANGE PLATE WEIGHT HORN

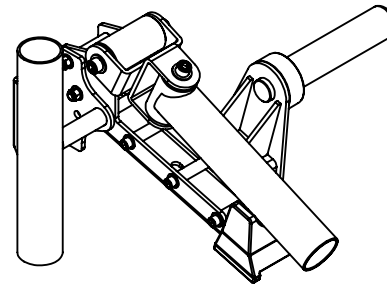

XCREATE-TP
TRIPLE PLAY

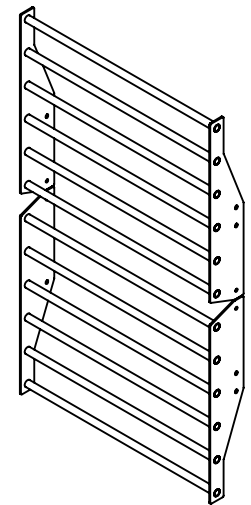

4OSB
4' OFFSET STALL BARS

**XCREATE-BHSE
BALL & HANGING
STORAGE EXTENSION**

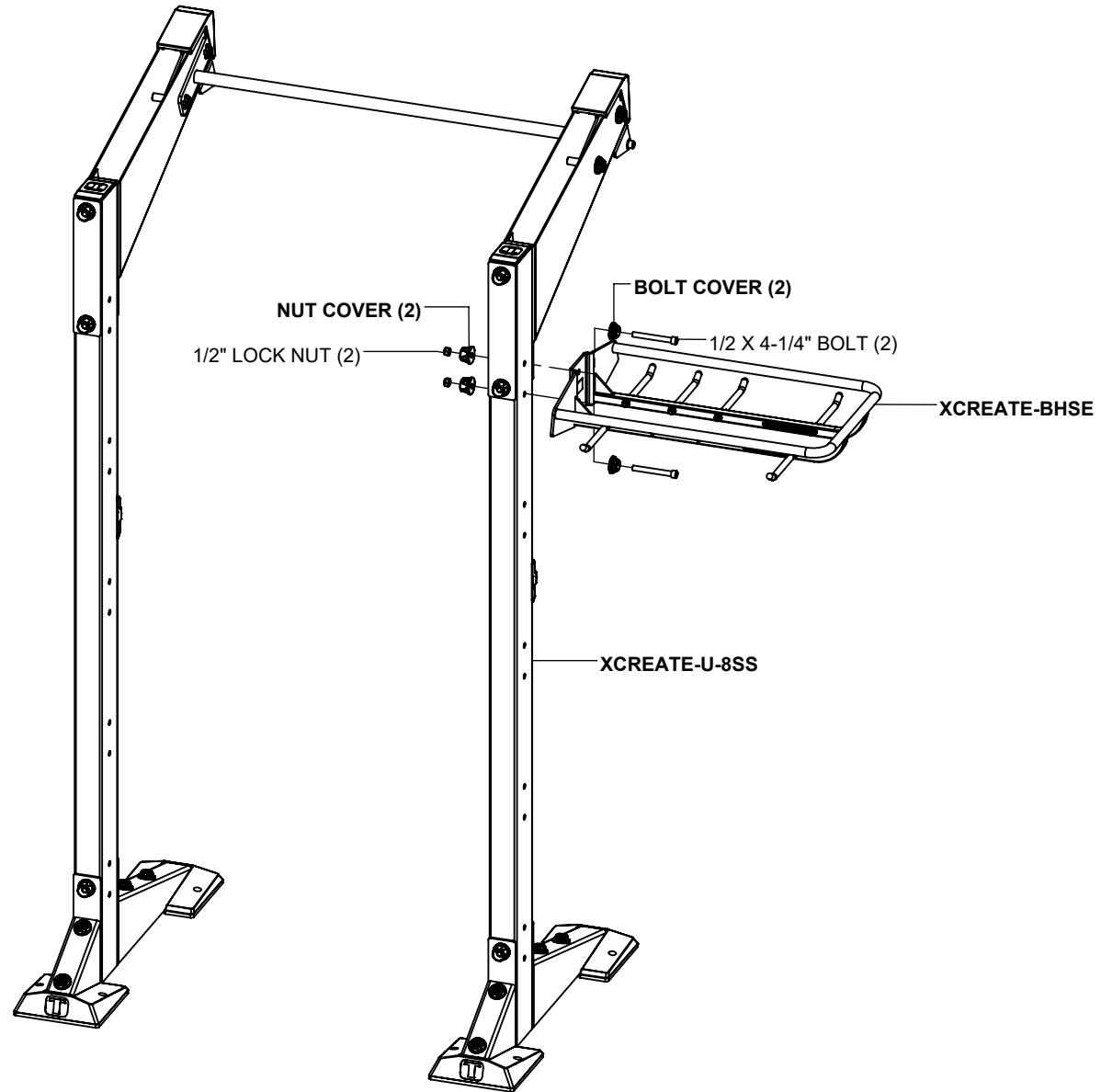

NOTES:

SECURELY tighten all bolt connections in this step.

The **XCREATE-U-7SS** is assembled the exact same way.

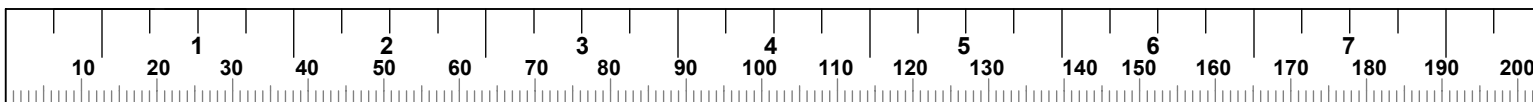

**XRACK-BRA
BATTLE ROPE ANCHOR**

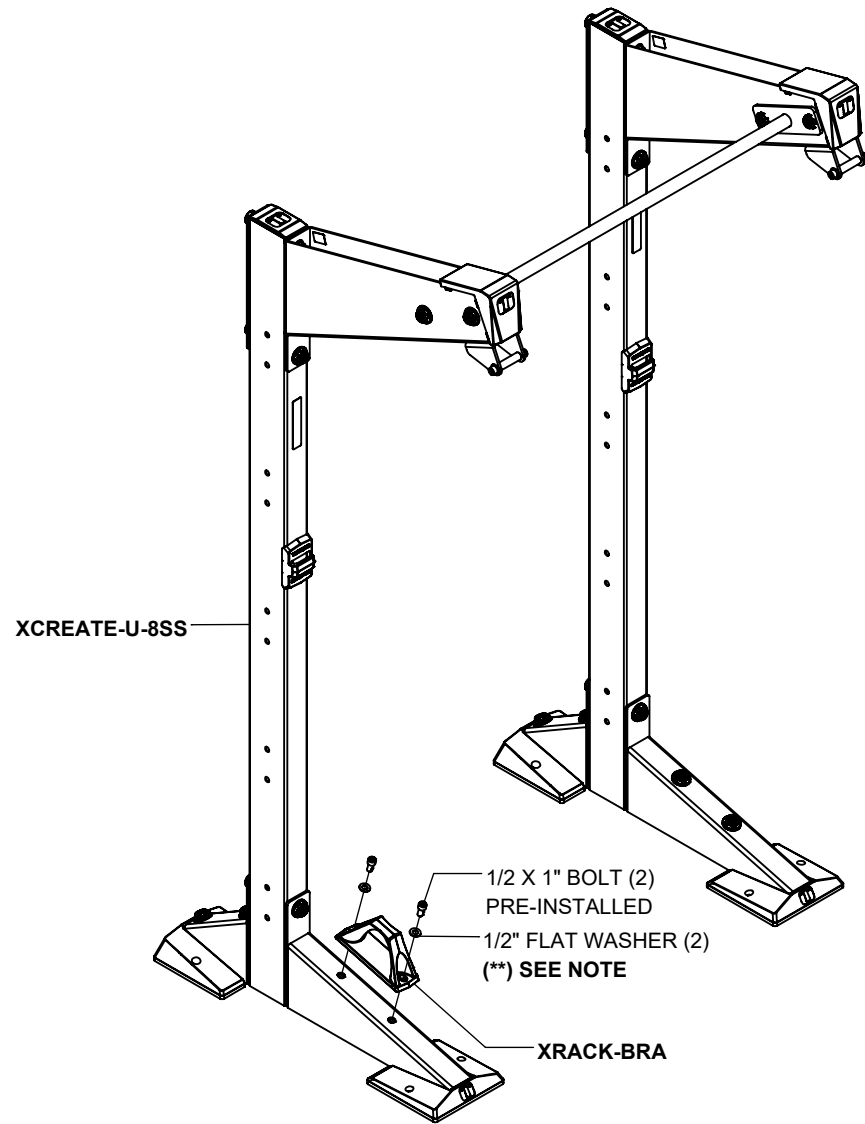

NOTES:

SECURELY tighten all bolt connections in this step.

(**) **HARDWARE COVERS CANNOT** be used in this step.

The **XCREATE-U-7SS** is assembled the exact same way.

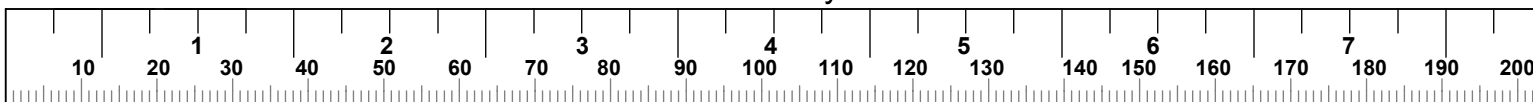

**XCREATE-HSH
HANGING STORAGE HOOK**

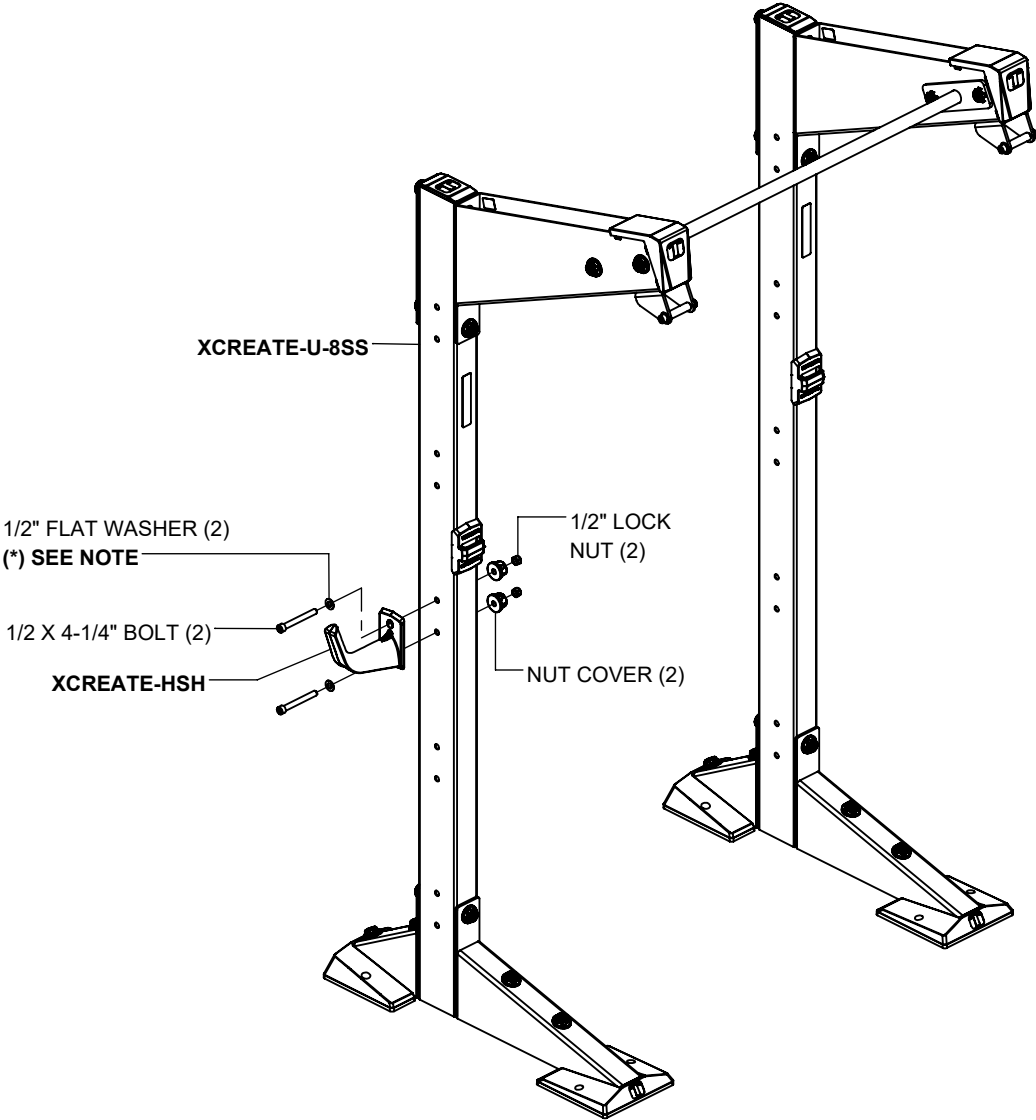

NOTES:

SECURELY tighten all bolt connections in this step.
 (**) **HARDWARE COVER CANNOT** be used on **HSH** side.
 The **XCREATE-U-7SS** is assembled the exact same way.

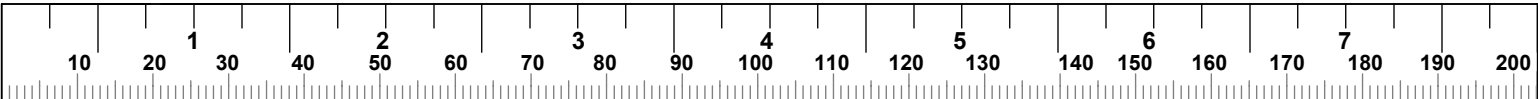

**XCREATE-DP
DOUBLE PLAY (BAR & PLATE STORAGE)**

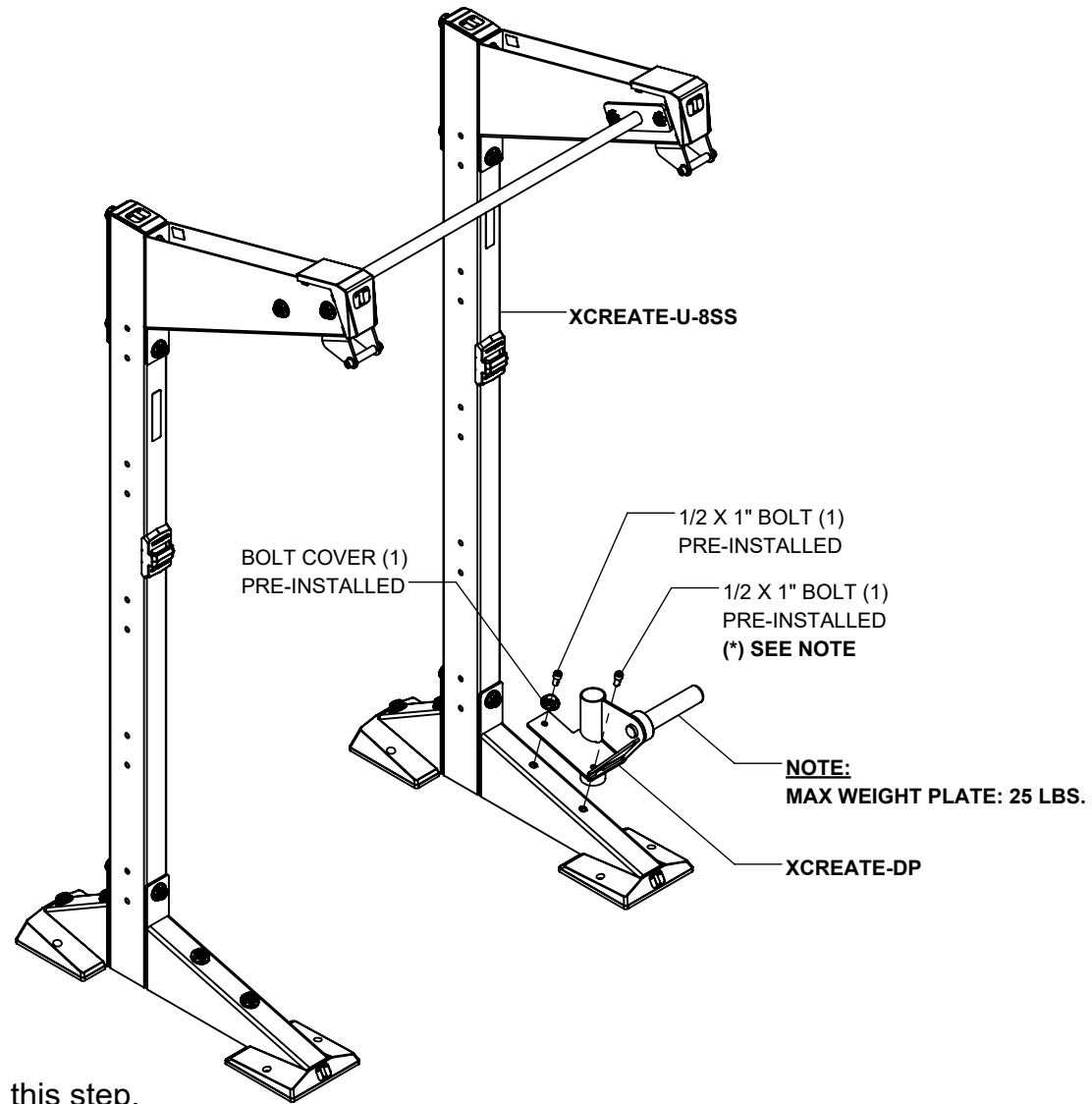

NOTES:

SECURELY tighten all bolt connections in this step.

(* **HARDWARE COVER CAN** be used in place of washer.
(SEE PAGE 3).

(** **HARDWARE COVER CANNOT** be used in place of washer.

The **XCREATE-U-7SS** is assembled the exact same way.

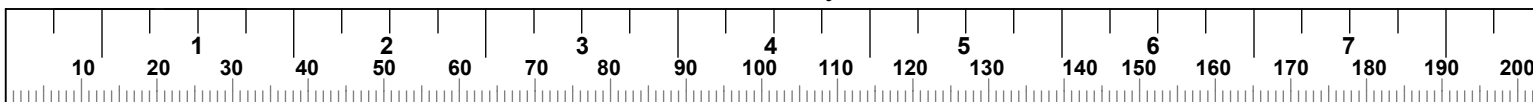

**XHMGRT
HORIZONTAL MOUNT GROUND
ROTATIONAL TRAINER**

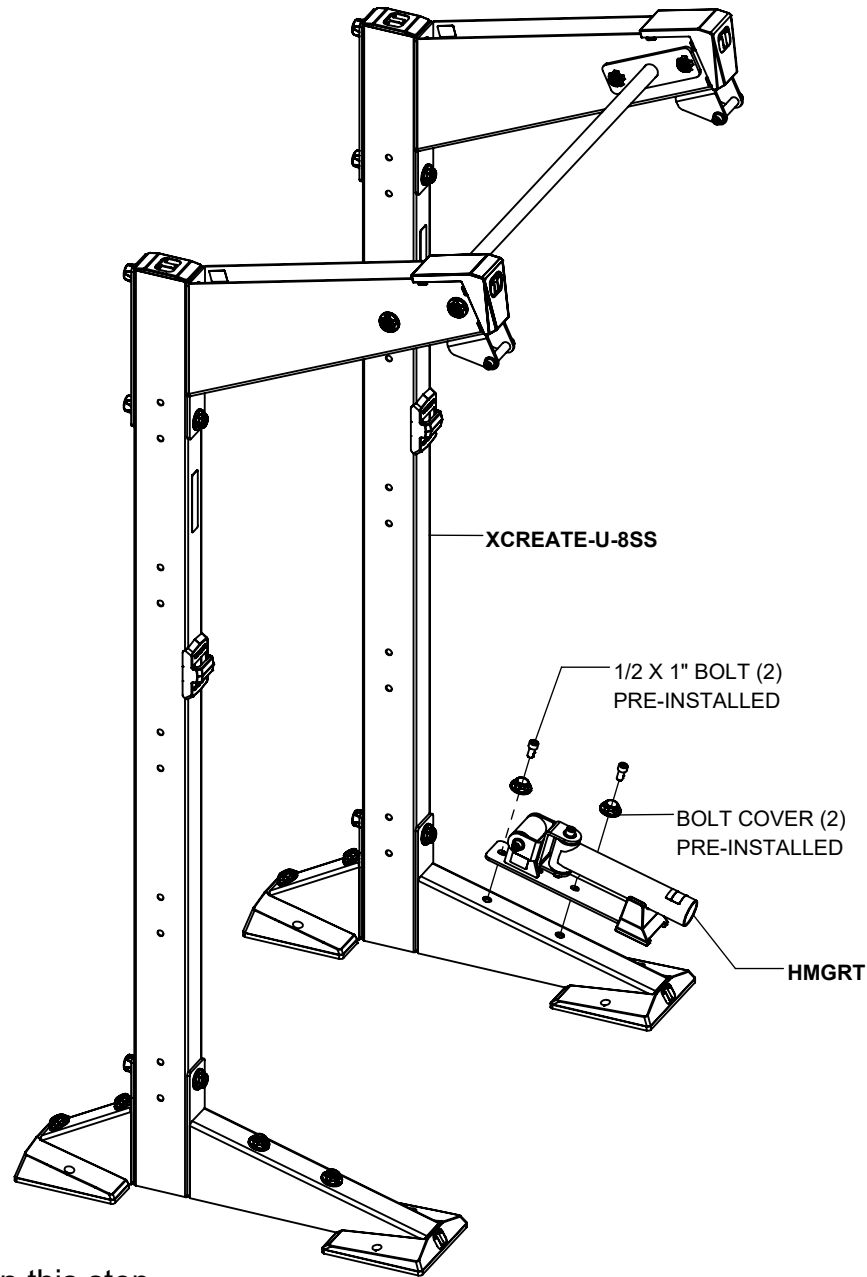

NOTES:

SECURELY tighten all bolt connections in this step.

The **XCREATE-U-7SS** is assembled the exact same way.

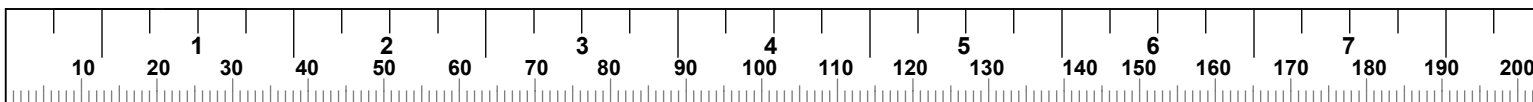

XCREATE-3DS
3 DIMENSIONAL SWIVEL

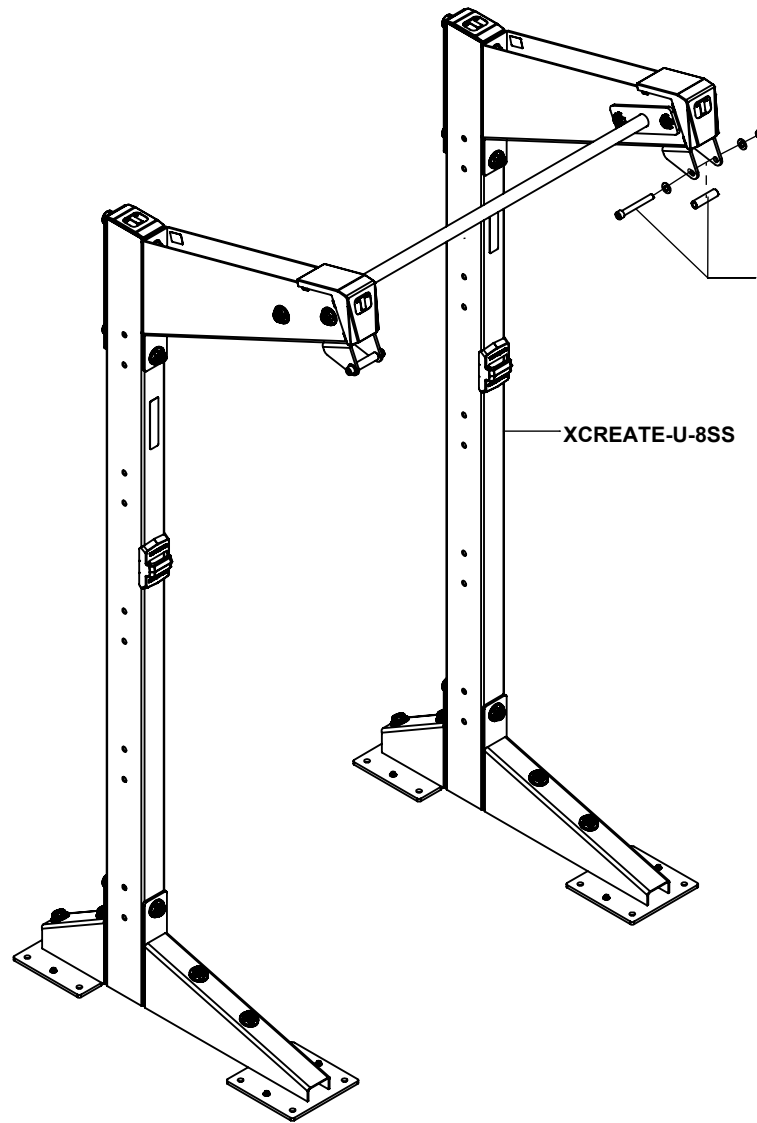

NOTE:
TEMPORARILY REMOVE BOLT,
SPACER, WASHERS AND NUT

XCREATE-U-8SS

XCREATE-3DS
3-DIMENSIONAL SWIVEL

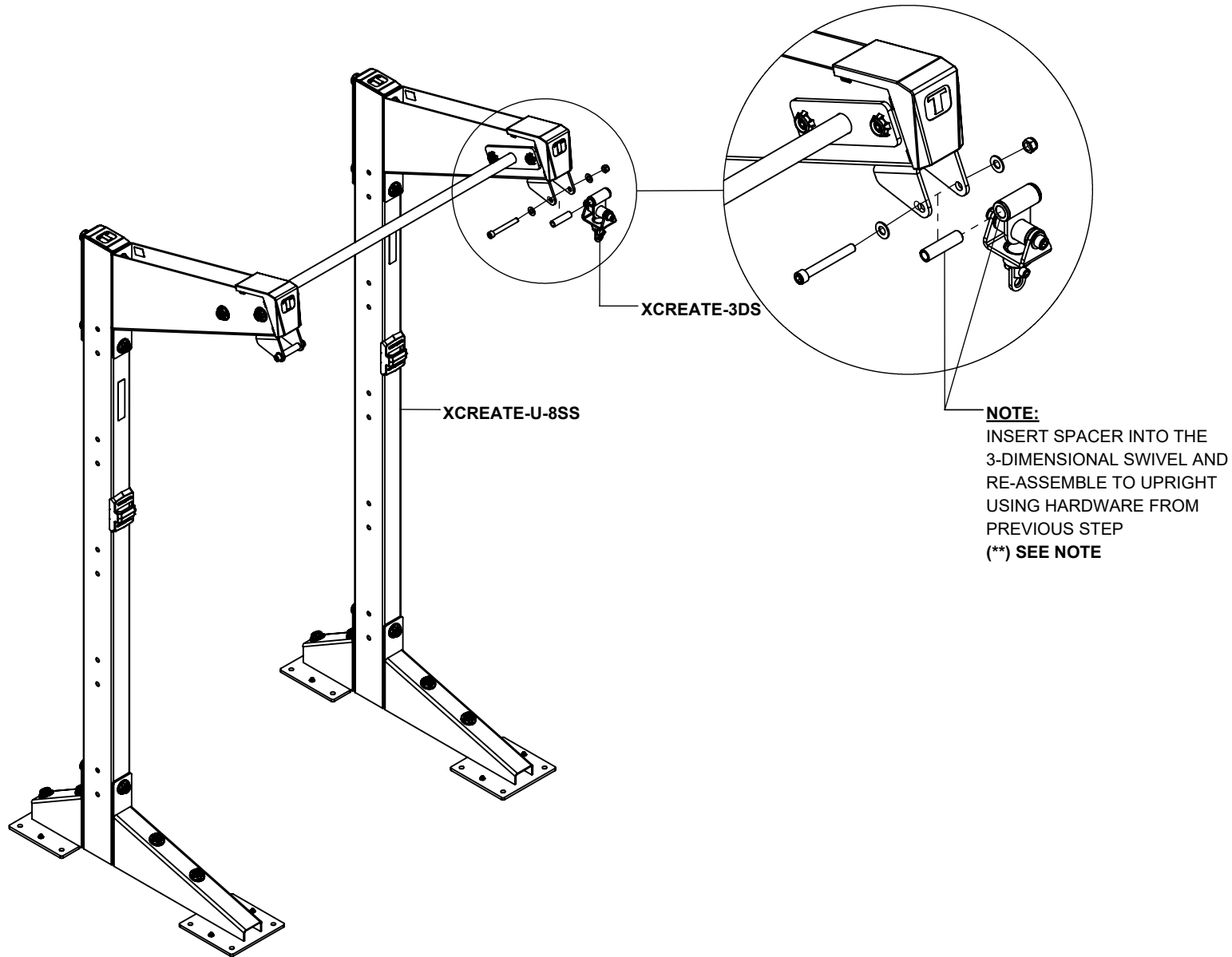

NOTES:

SECURELY assemble bolt connection in this step.

(**) **HARDWARE COVERS** **CANNOT** be used in place of washers in this step.

XCREATE-BT BALL TARGET

NOTE:

REMOVE SPACERS
(2) AND DISCARD

NOTE:

REMOVE END CAP
AND DISCARD

NOTE:

TEMPORARILY REMOVE
BOLTS, HARDWARE COVERS AND NUTS

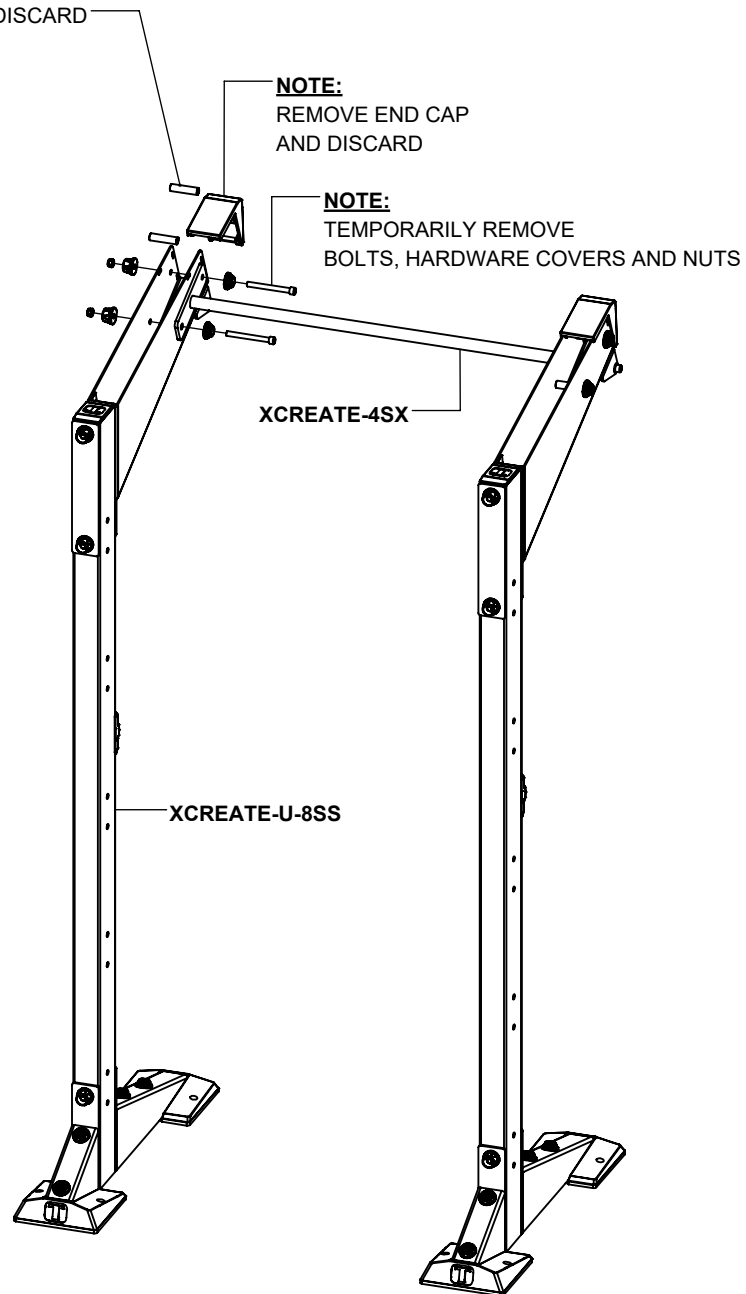

XCREATE-BT BALL TARGET

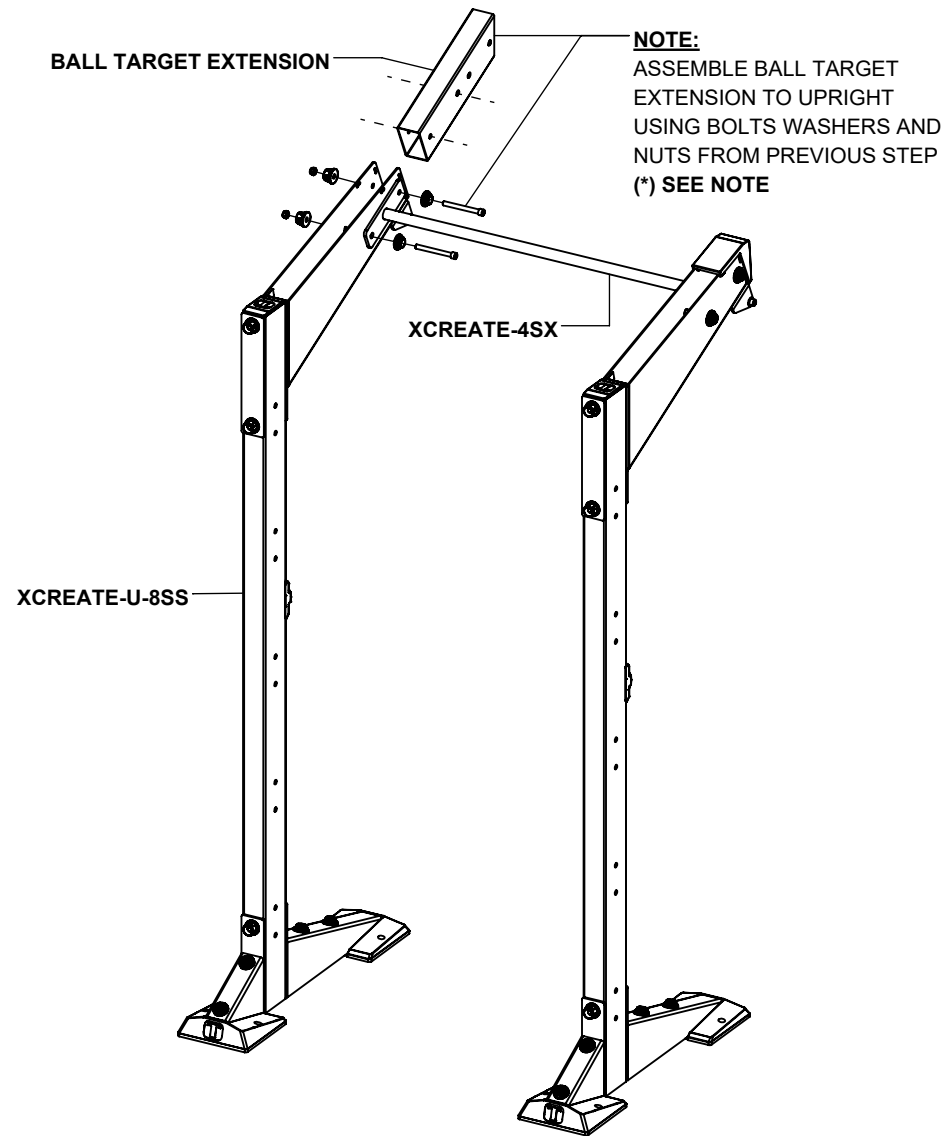

NOTES:

LOOSELY assemble bolt connections in this step.

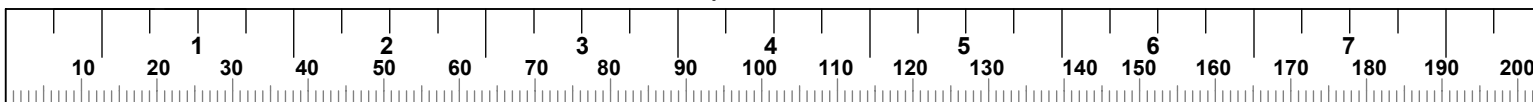

XCREATE-BT BALL TARGET

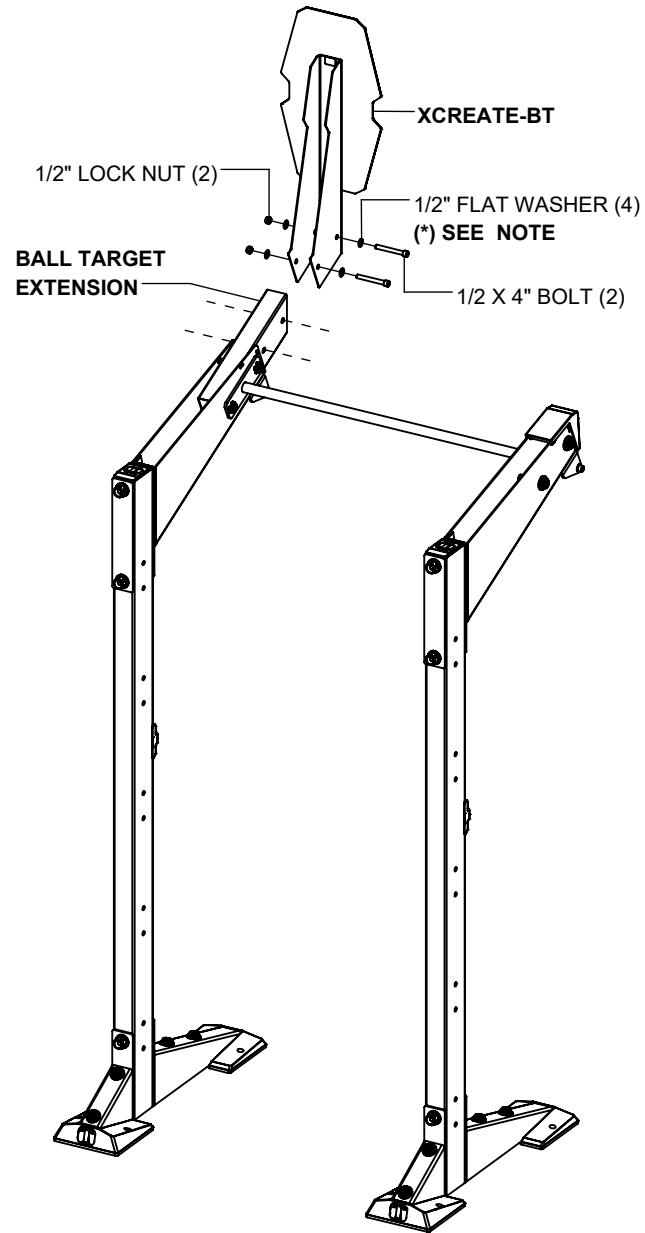

NOTES:

After this step has been completed, **SECURELY** tighten all bolt connections from the last two steps.

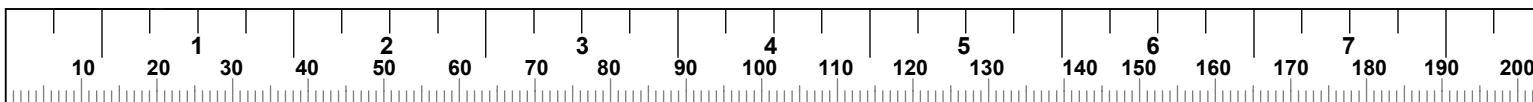

**XCREATE-RBA
RESISTANCE BAND ANCHOR**

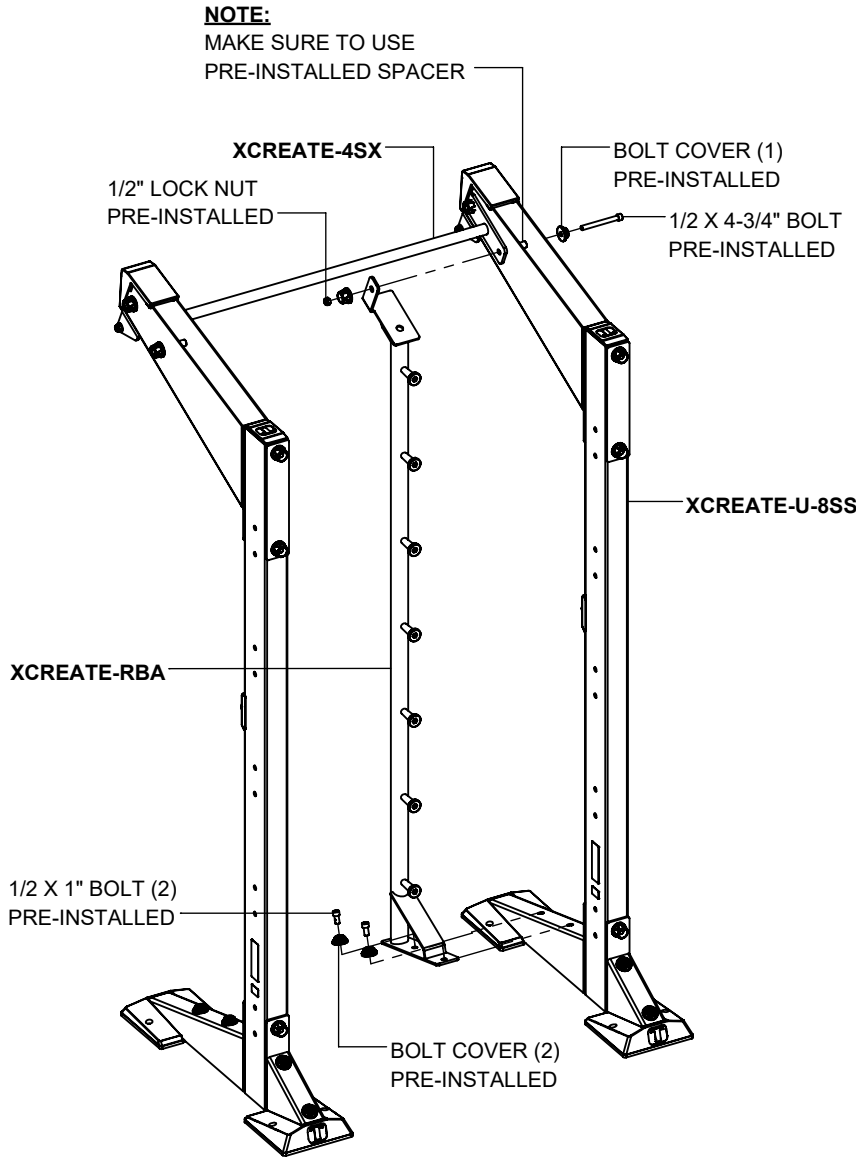

NOTES:

SECURELY tighten all bolt connections in this step.

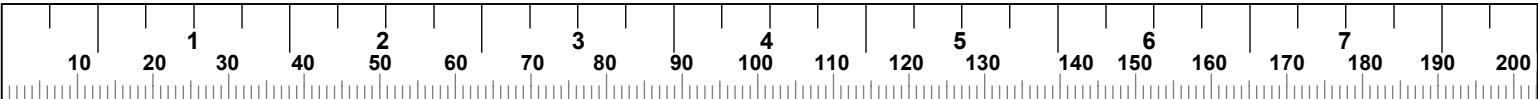

**XCREATE-VDS4 AND VDS5
VERTICAL DUMBBELL STORAGE**

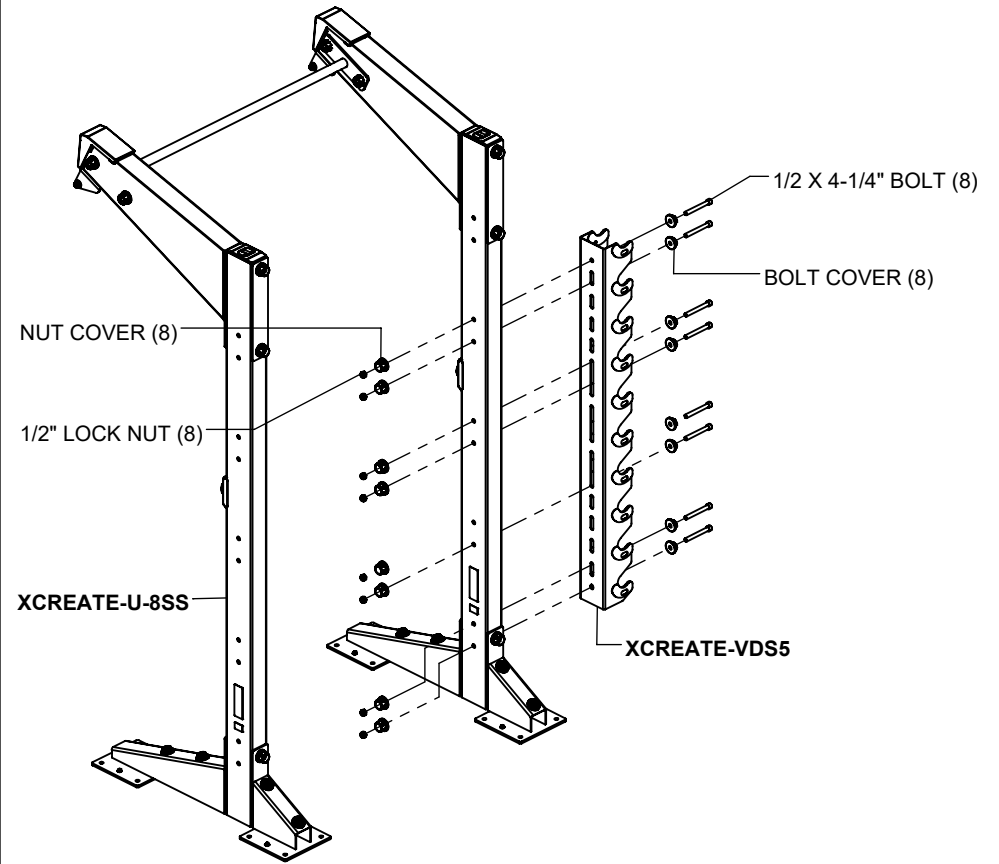
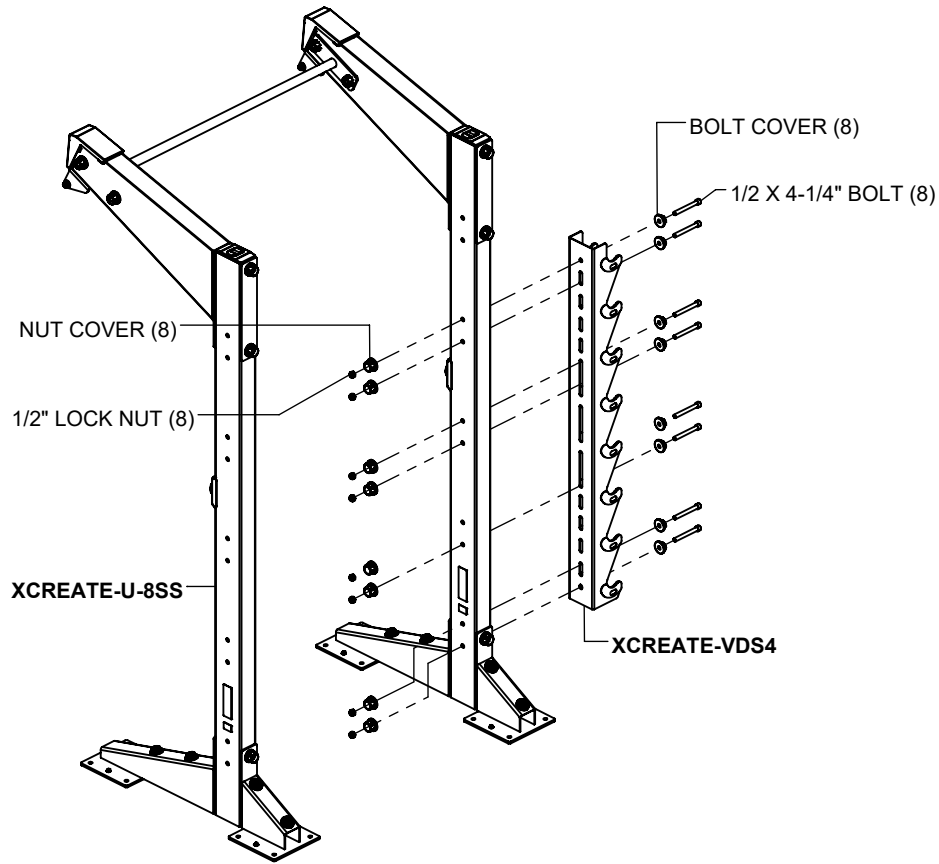

NOTES:

SECURELY tighten all bolt connections in this step.

The **XCREATE-U-7SS** is assembled the exact same way.

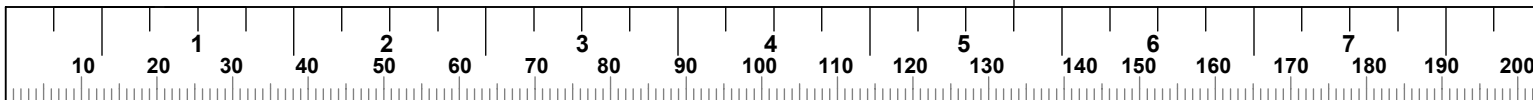

**XCREATE-4MGX
4' MULTI GRIP CROSS**

NOTE:
REMOVE END CAPS PRIOR
TO ASSEMBLY RE-ATTACH
END CAPS AFTER ASSEMBLY (2)

NUT COVER (4)
(PRE-INSTALLED)

1/2" LOCK NUT (4)
(PRE-INSTALLED)

NOTE:
MAKE SURE TO USE PRE-
INSTALLED SPACERS (4)

BOLT COVER (4)
(PRE-INSTALLED)

1/2 X 4-3/4" BOLT (4)
(PRE-INSTALLED)

XCREATE-4MGX

XCREATE-U-8SS (2)

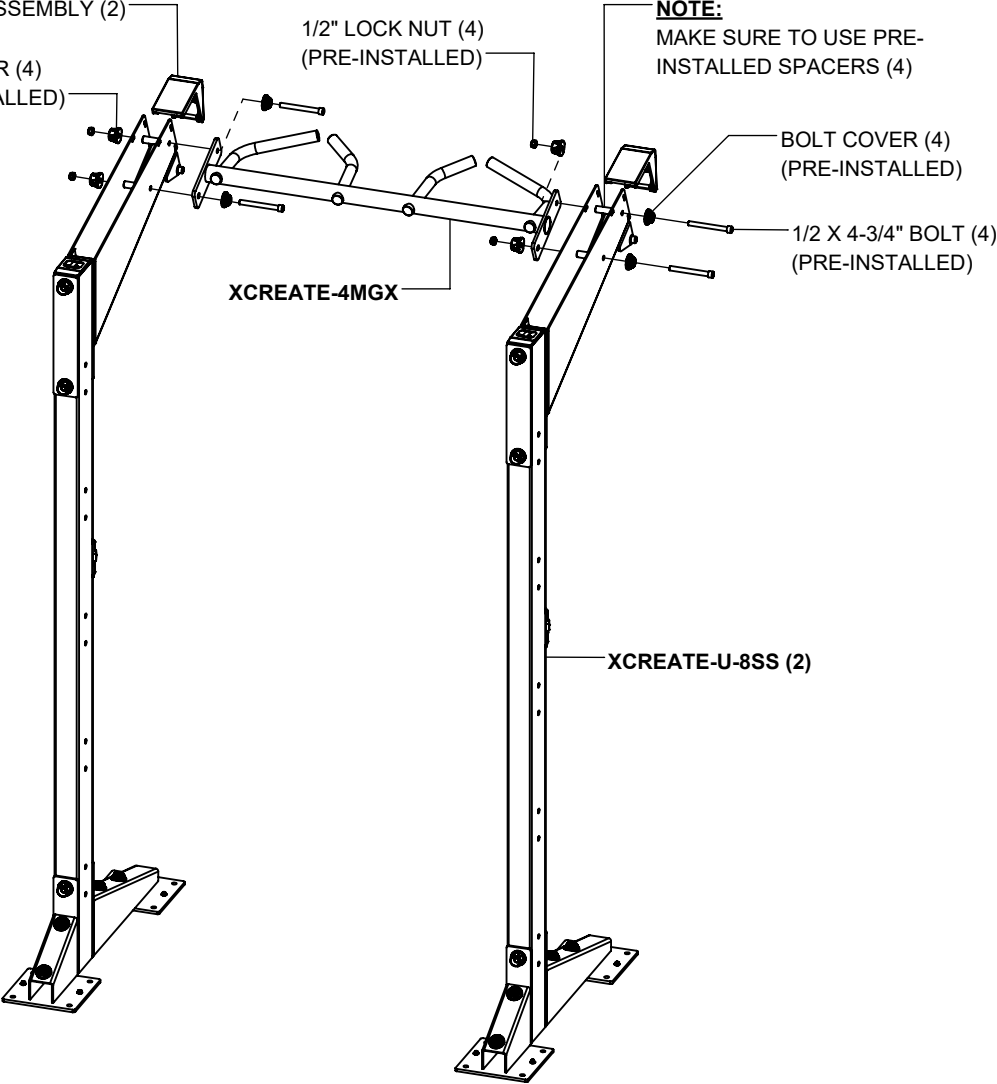

NOTES:

SECURELY tighten all bolt connections in this step.

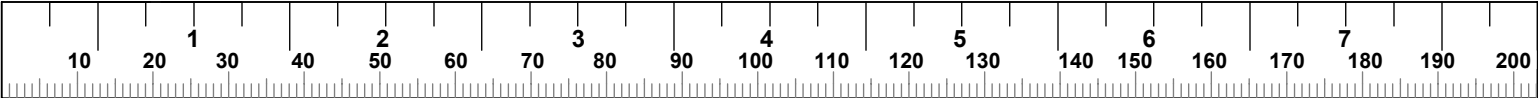

XCREATE-4SSHWS
4' SINGLE SIDE HORIZONTAL WEIGHT STORAGE

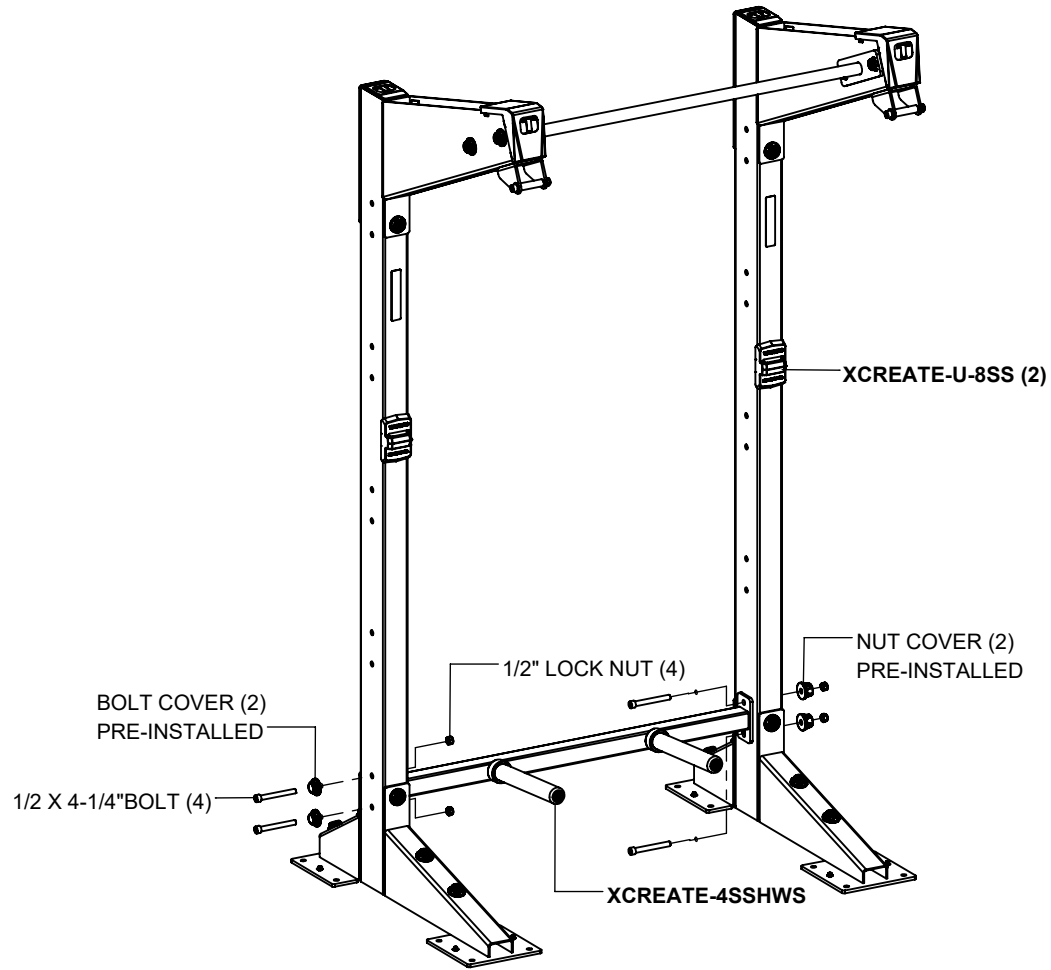

NOTES:

SECURELY tighten all bolt connections in this step.

(**) **HARDWARE COVERS CANNOT** be used on plate side.

The **XCREATE-U-7SS** is assembled the exact same way.

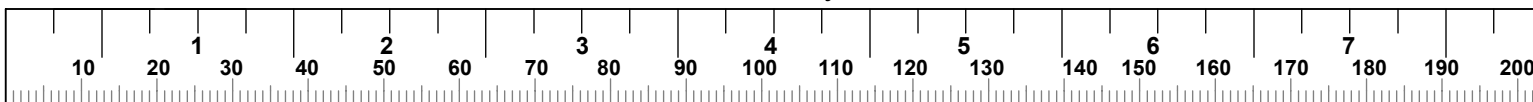

**XCREATE-TBE
TOP BOOM EXTENSION**

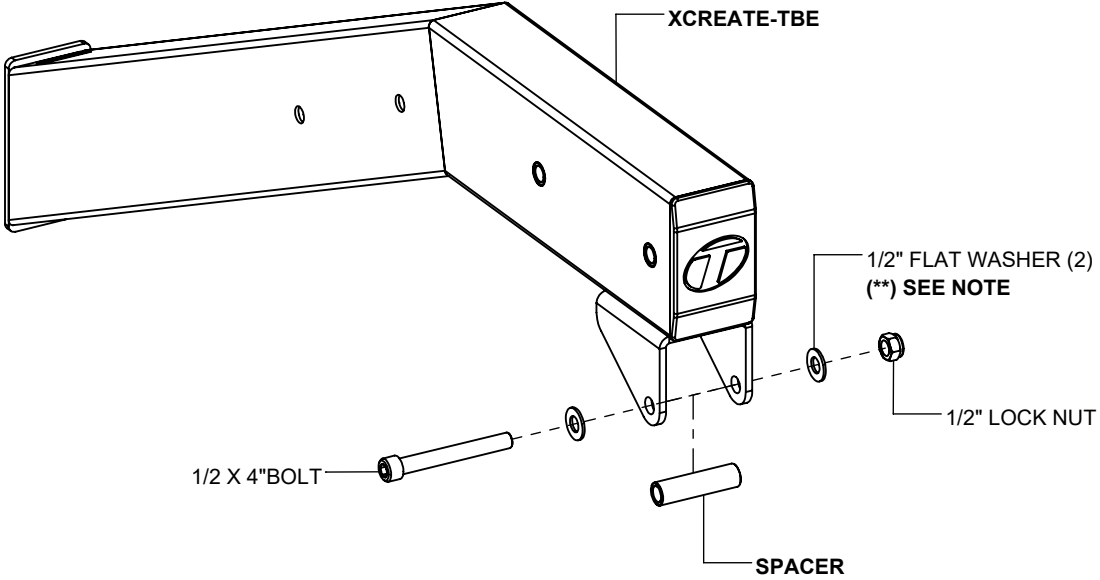

NOTES:

SECURELY tighten bolt connection in this step.

(**) **HARDWARE COVERS CANNOT** be used in place of washers in this step.

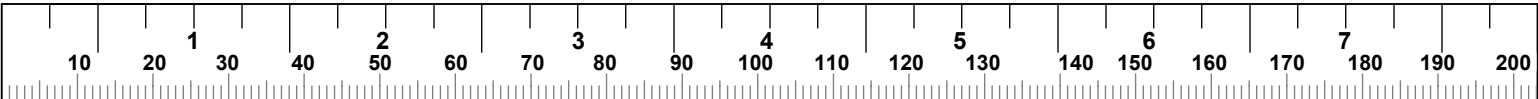

**XCREATE-TBE
TOP BOOM EXTENSION**

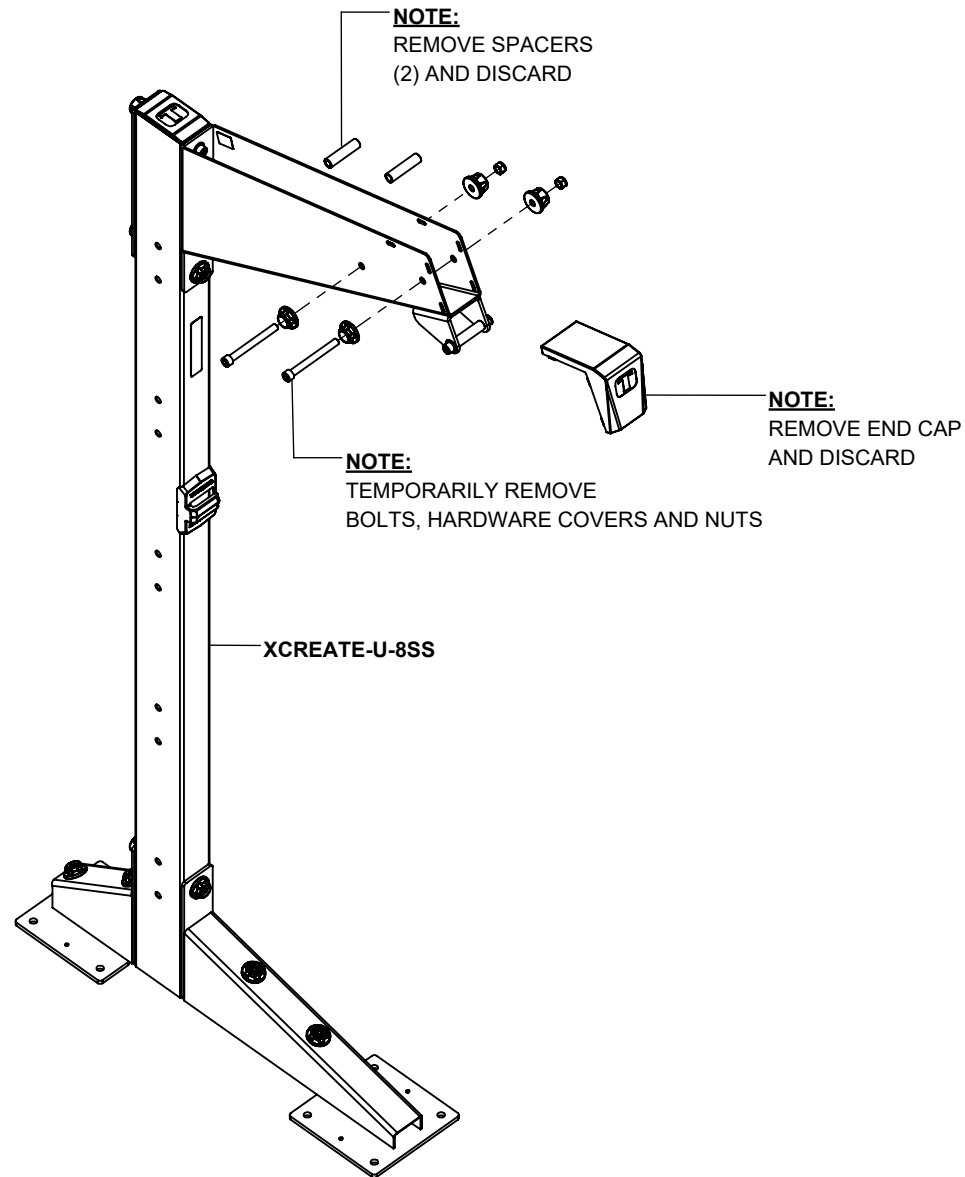

NOTE:

Repeat this step for as many TOP BOOM EXTENSIONS there are to assemble.

**XCREATE-TBE
TOP BOOM EXTENSION**

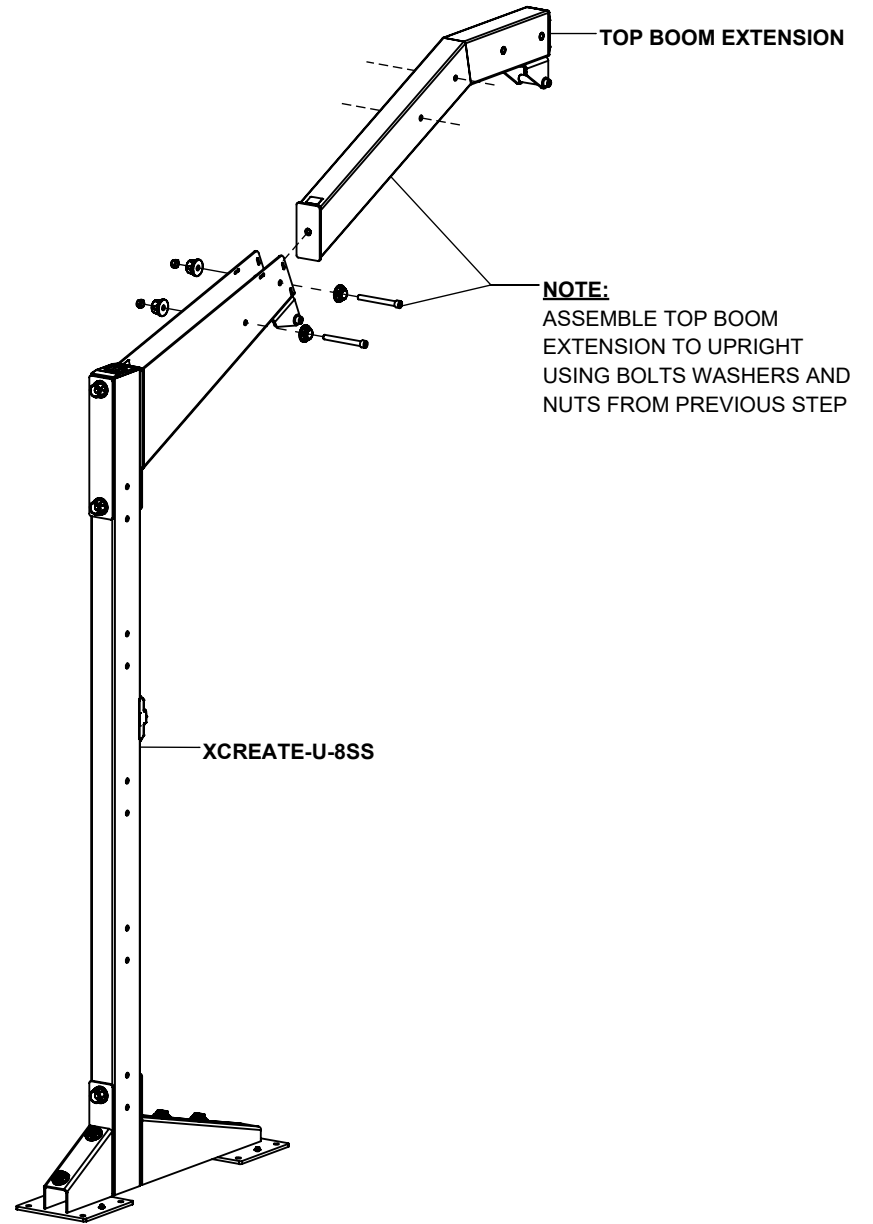

NOTES:

Repeat this step for as many TOP BOOM EXTENSIONS there are to assemble.

If only one TOP BOOM EXTENSION is being assembled, then **SECURELY** tighten all bolt connections in this step.

If joining two TOP BOOM EXTENSIONS together, then keep all bolt connections loose until next step.

(*) HARDWARE COVERS **CAN** be used in place of washers in this step. (SEE PAGE 3).

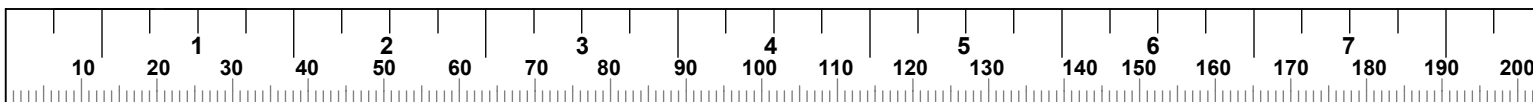

**XCREATE-TBE
TOP BOOM EXTENSION**

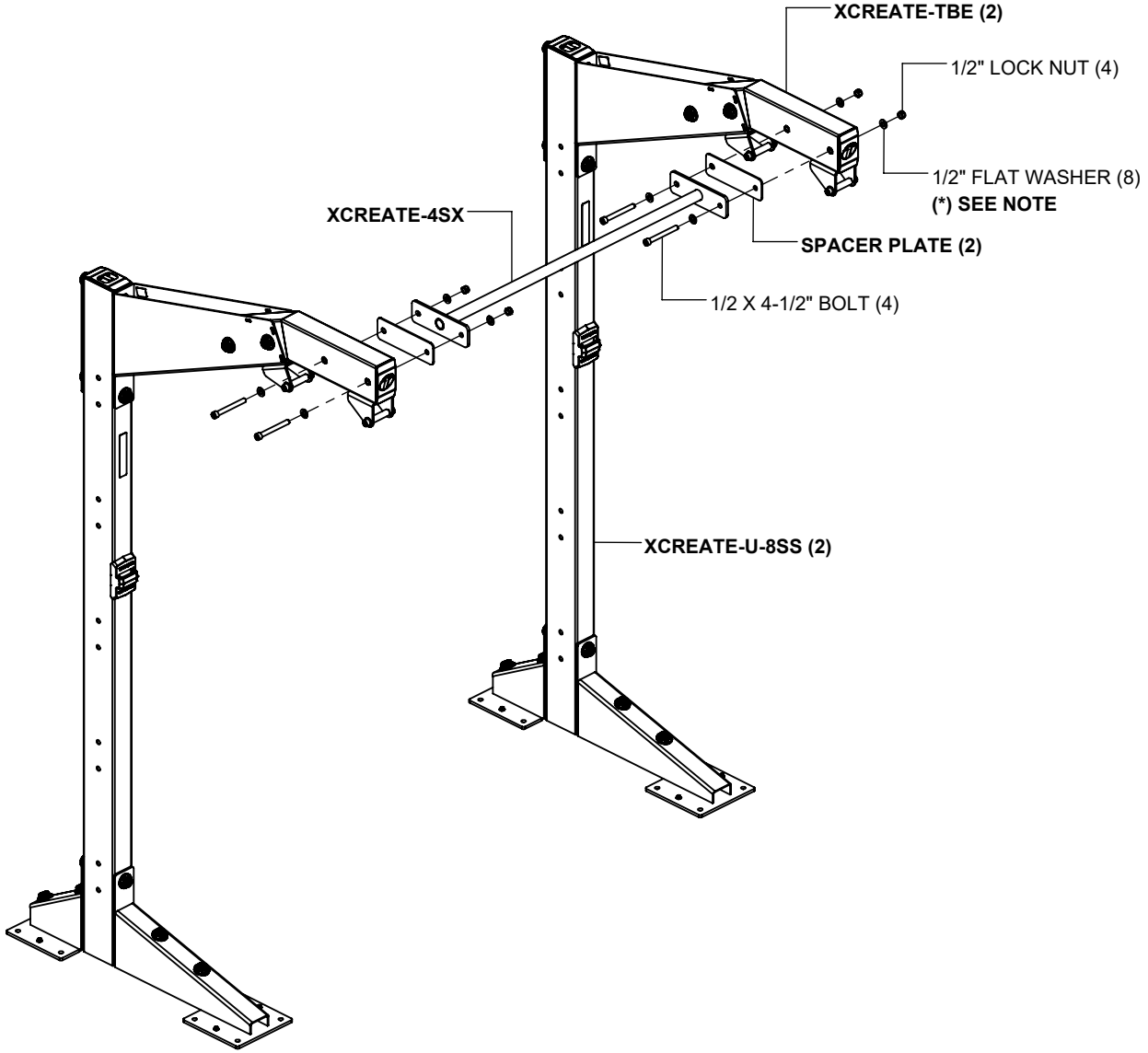

NOTES:

SECURELY tighten all bolt connections in this step.

(* **HARDWARE COVERS CAN** be used in place of washers in this step. **(SEE PAGE 3)**).

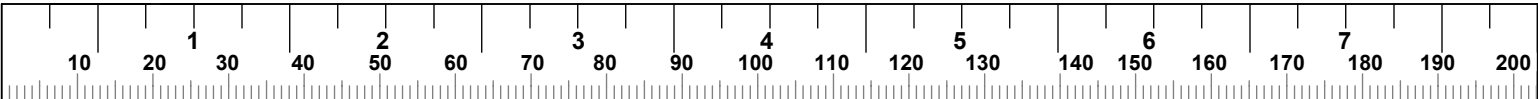

XCREATE-AA ATTACHMENT ANCHOR

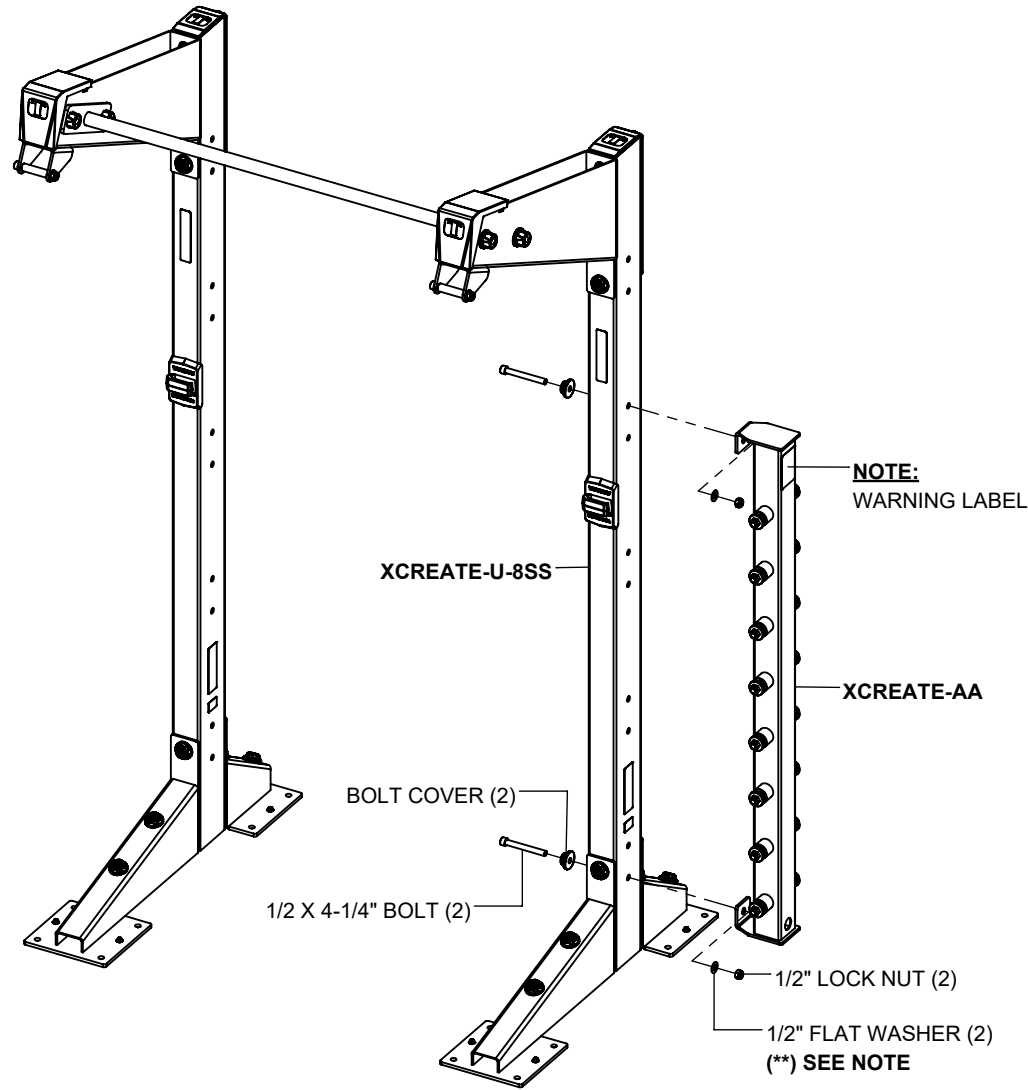

NOTES:

SECURELY tighten all bolt connections in this step.

(**) **HARDWARE COVERS CANNOT** be used on plate side.

The **XCREATE-U-7SS** is assembled the exact same way.

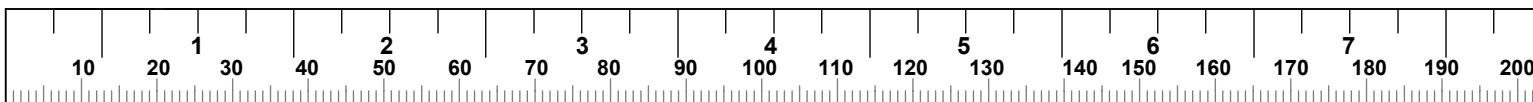

**XCREATE-DA
DIP ATTACHMENT**

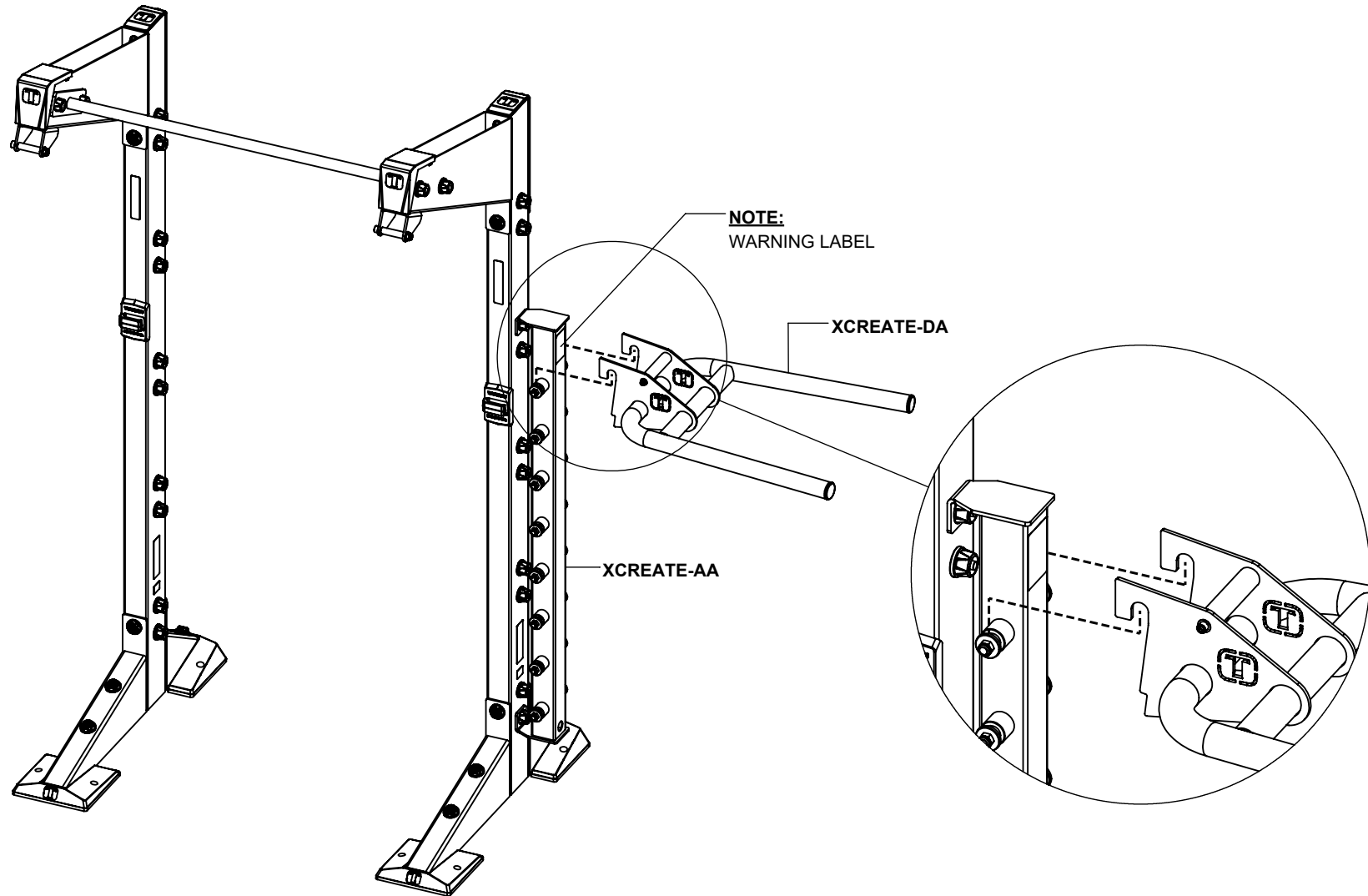

**XCREATE-PS
PLYO STEP**

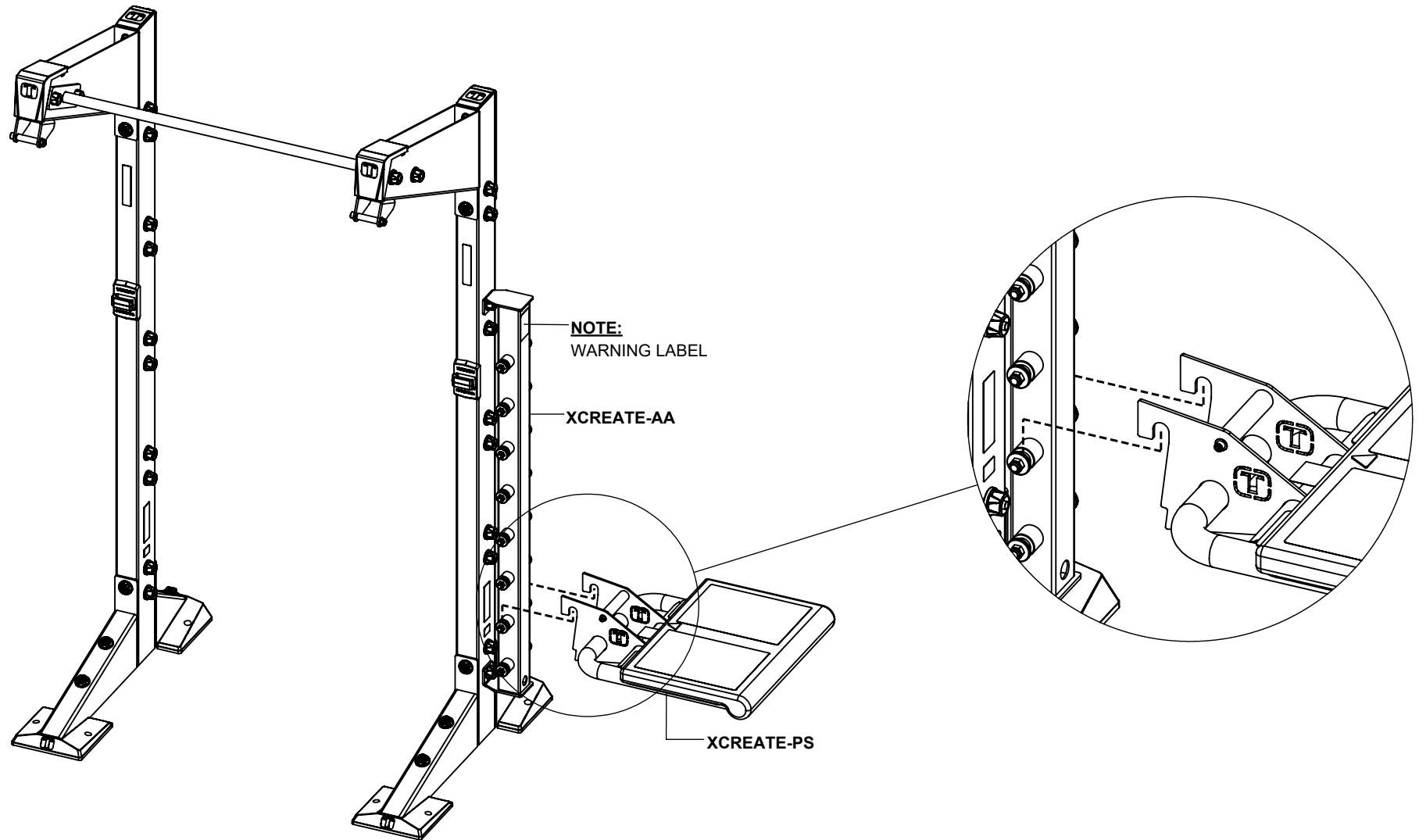

**XCREATE-AE
ATTACHMENT EXTENSION**

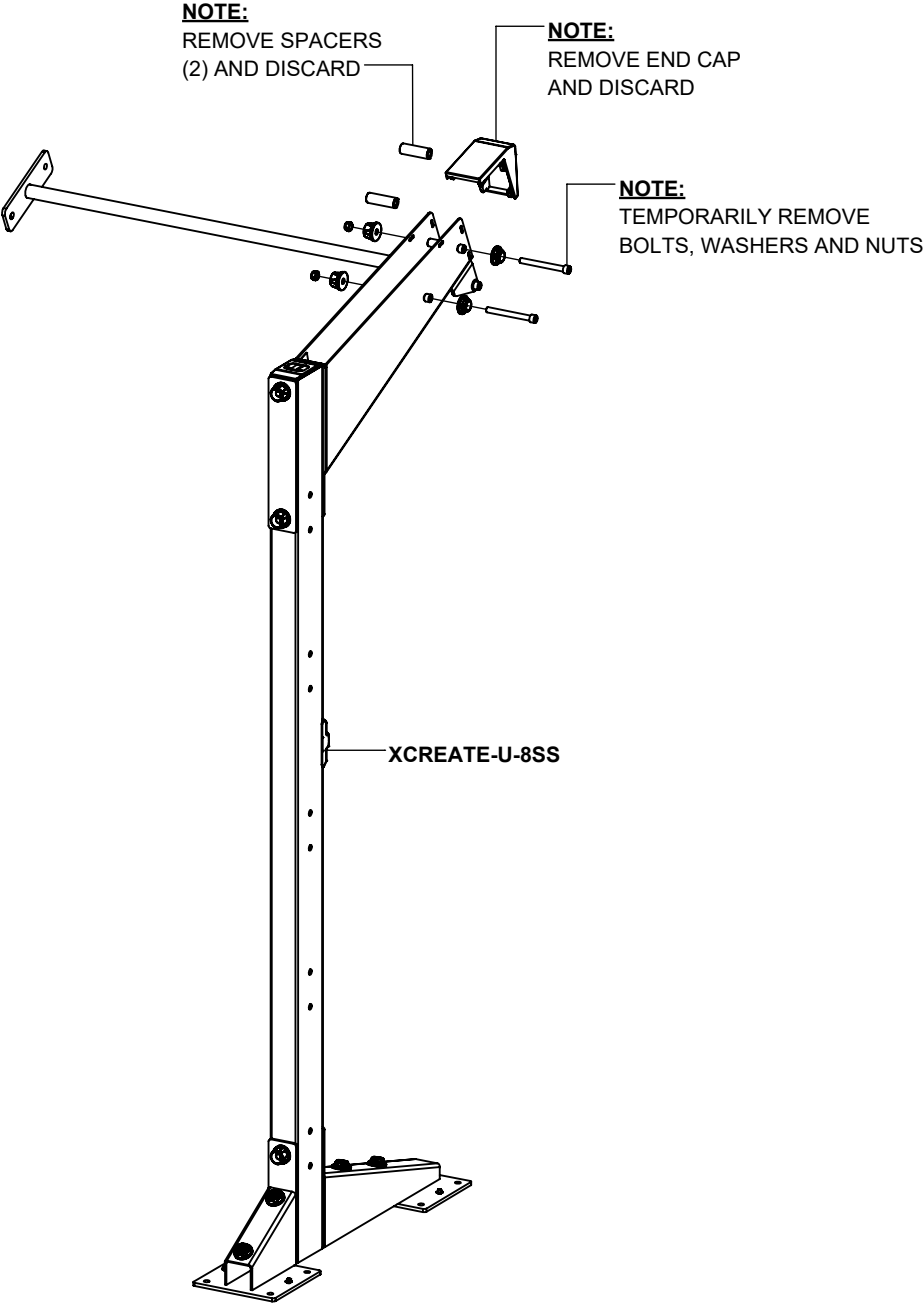

XCREATE-AE ATTACHMENT EXTENSION

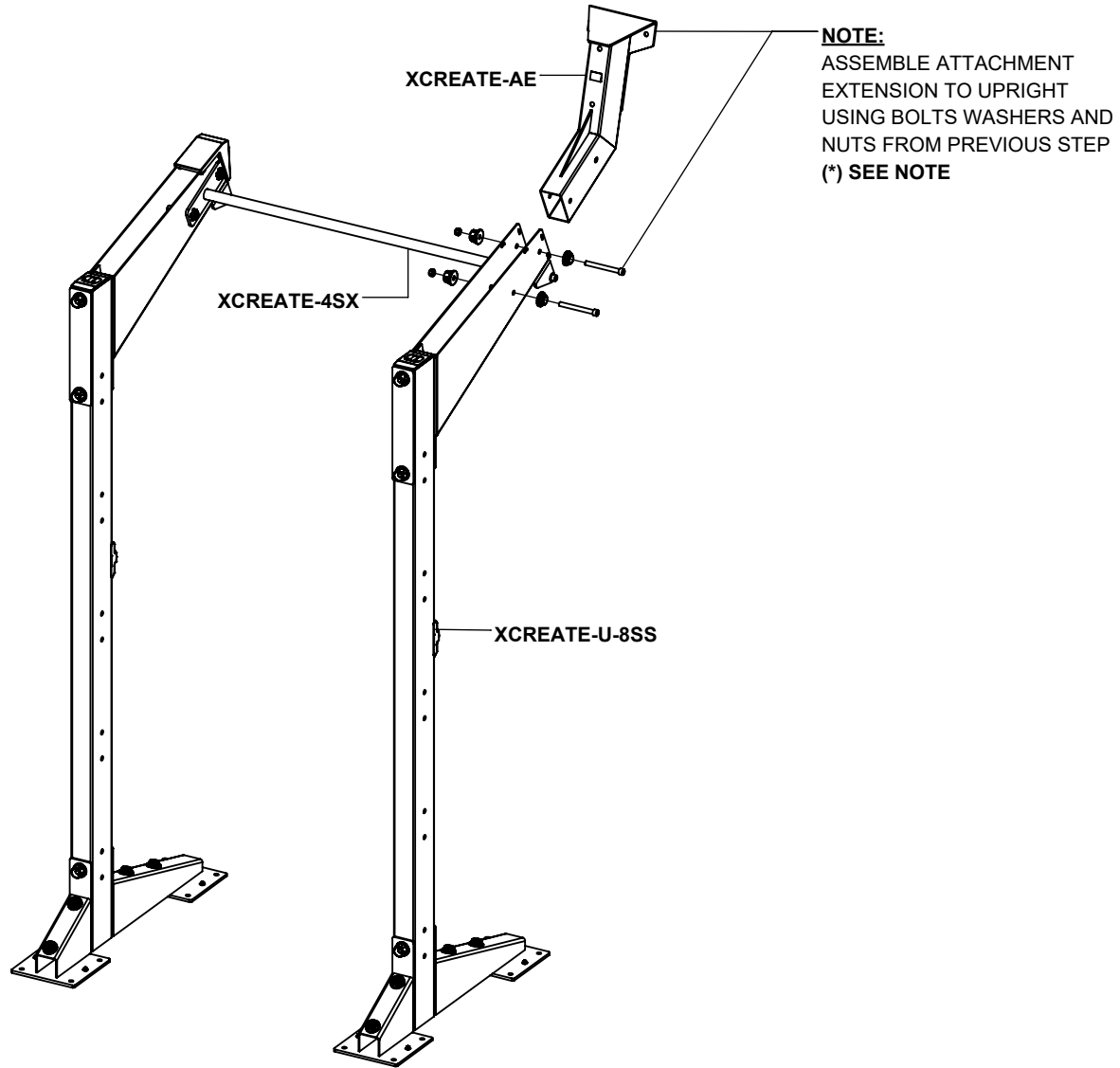

NOTES:

SECURELY assemble bolt connections in this step.

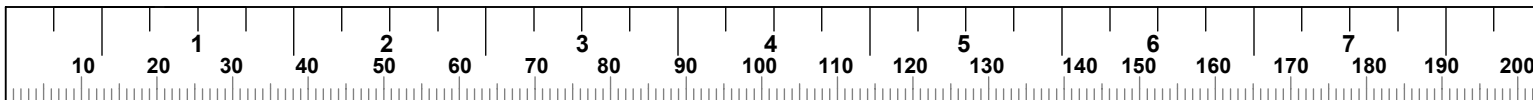

XCREATE-AE & XCREATE-3DSM ATTACHMENT EXTENSION AND 3 DIMENSIONAL SWIVEL W MOUNT

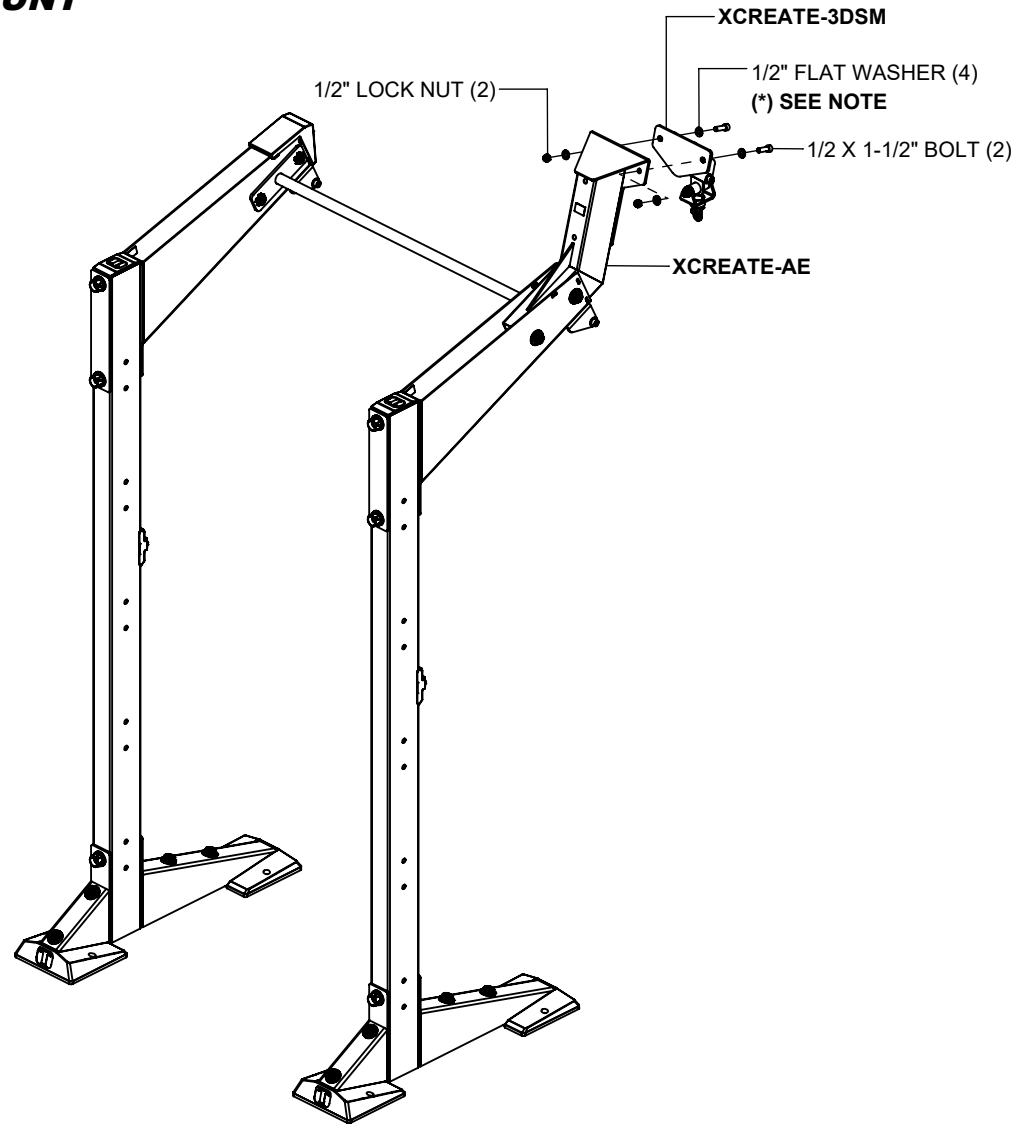

NOTES:

SECURELY assemble bolt connections in this step.

(*) **HARDWARE COVERS** **CAN** be used in place of washers in this step. **(SEE PAGE 3)**.

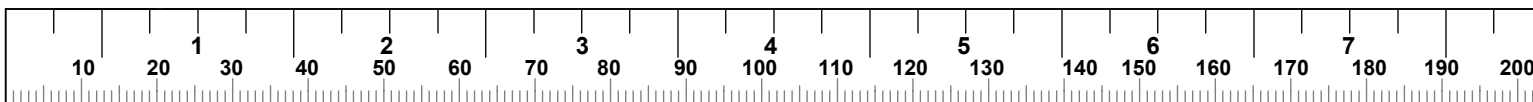

**XERT
RELENTLESS ROPE TRAINER (UPRIGHT MOUNT)**

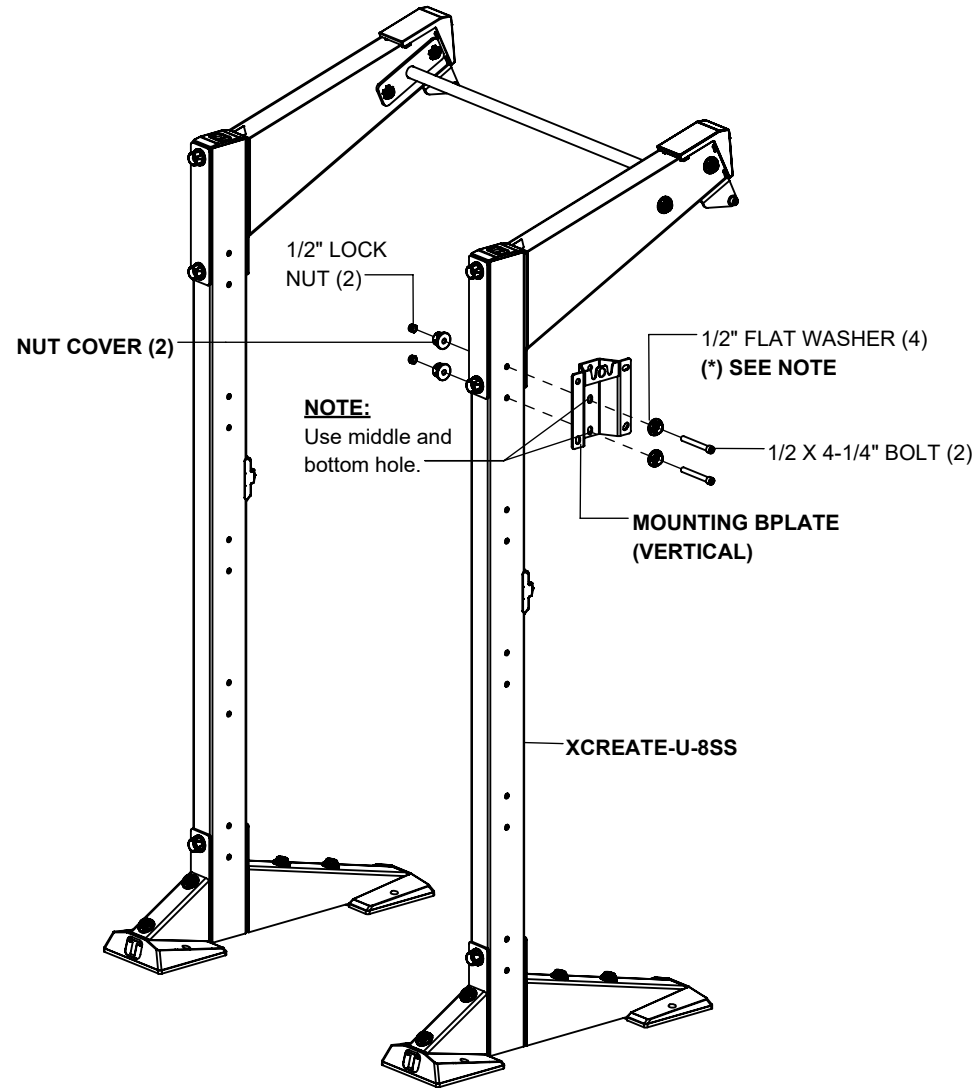

NOTES:

SECURELY tighten all bolt connections in this step.

(*) HARDWARE COVERS **CAN** be used in place of washers in this step. (SEE PAGE 3).

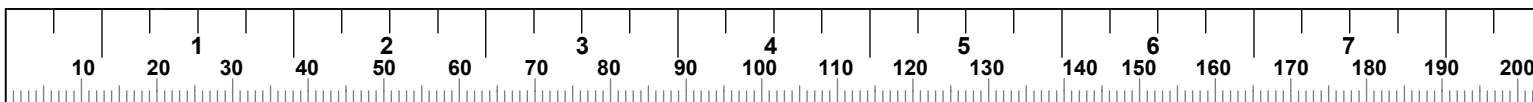

XERT
RELENTLESS ROPE TRAINER (UPRIGHT MOUNT)

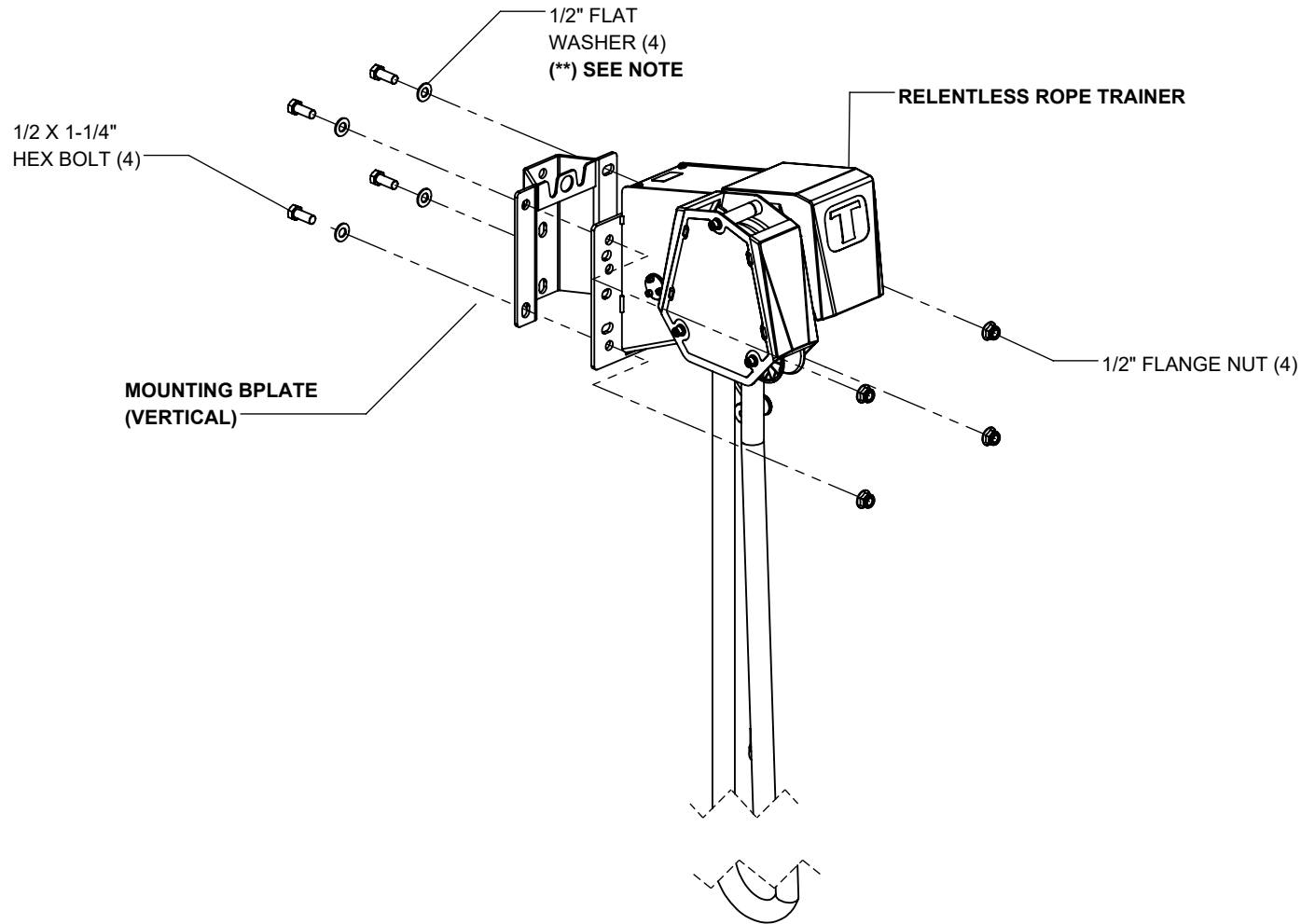

NOTES:

SECURELY tighten all bolt connections in this step.

(**) **HARDWARE COVERS CANNOT** be used in place of washers in this step.

XCREATE has been hidden for assembly clarity.

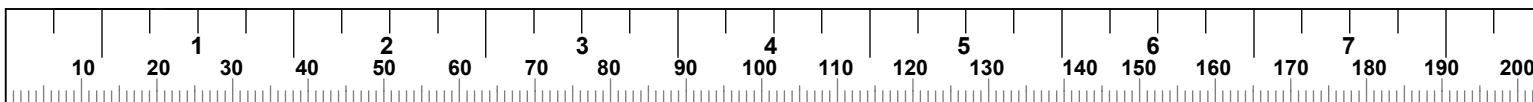

**XCREATE-BMXERT
BOOM MOUNT**

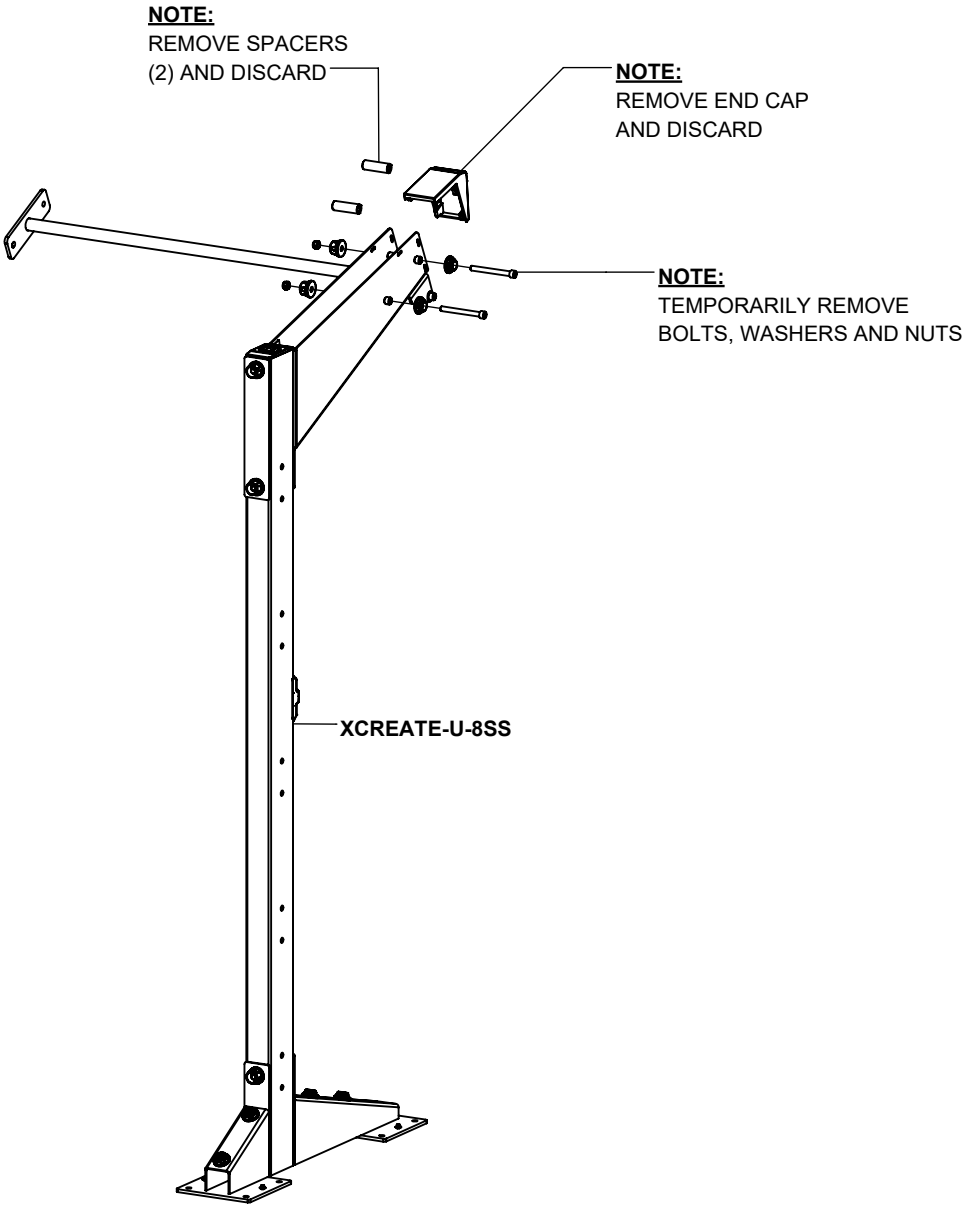

XCREATE-BMXERT BOOM MOUNT

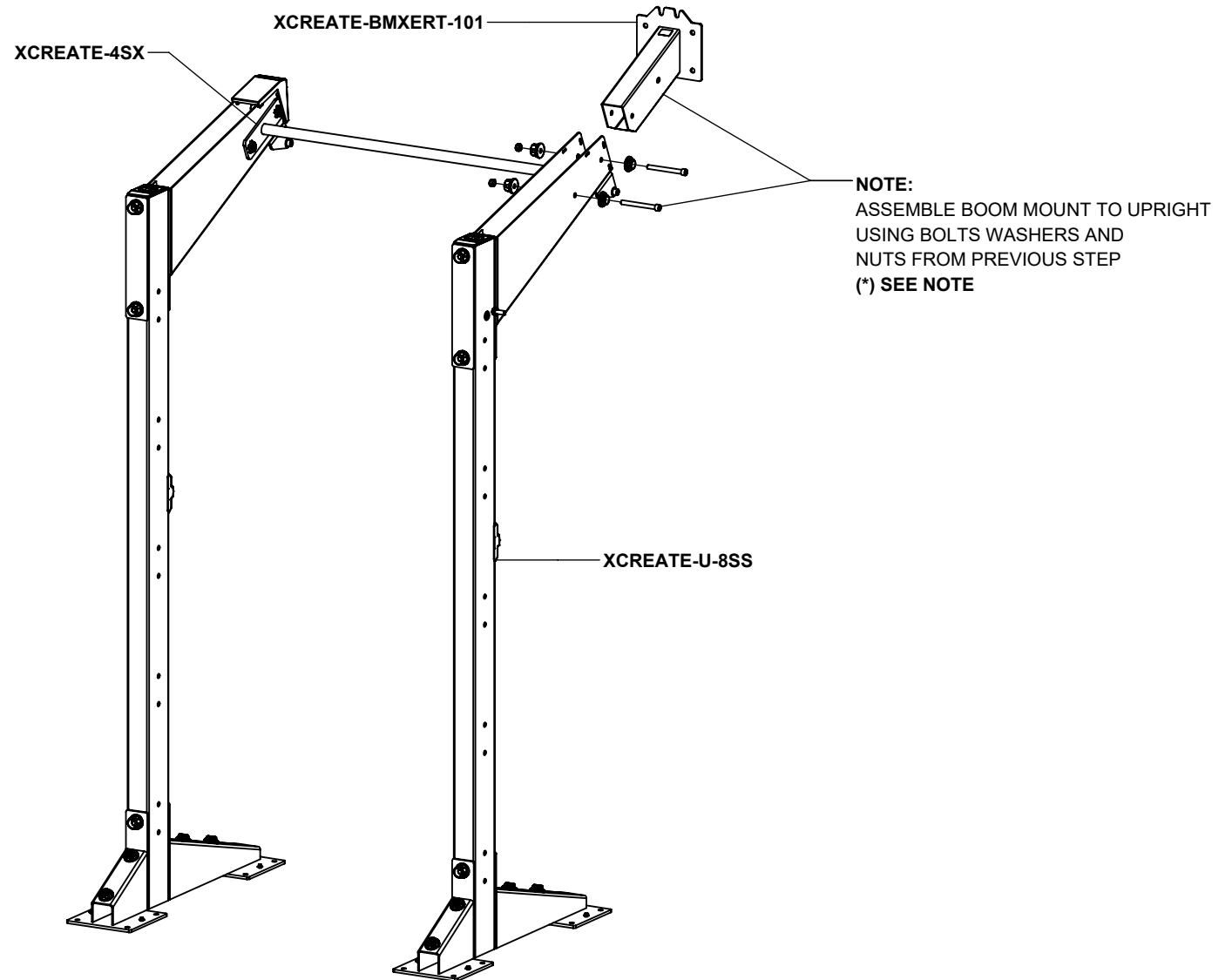

NOTE:

SECURELY tighten all bolt connections in this step.

(*) HARDWARE COVERS **CAN** be used in place of washers in this step. (SEE PAGE 3)

XCREATE-BMXERT RELENTLESS ROPE TRAINER / RELENTLESS RIPPER

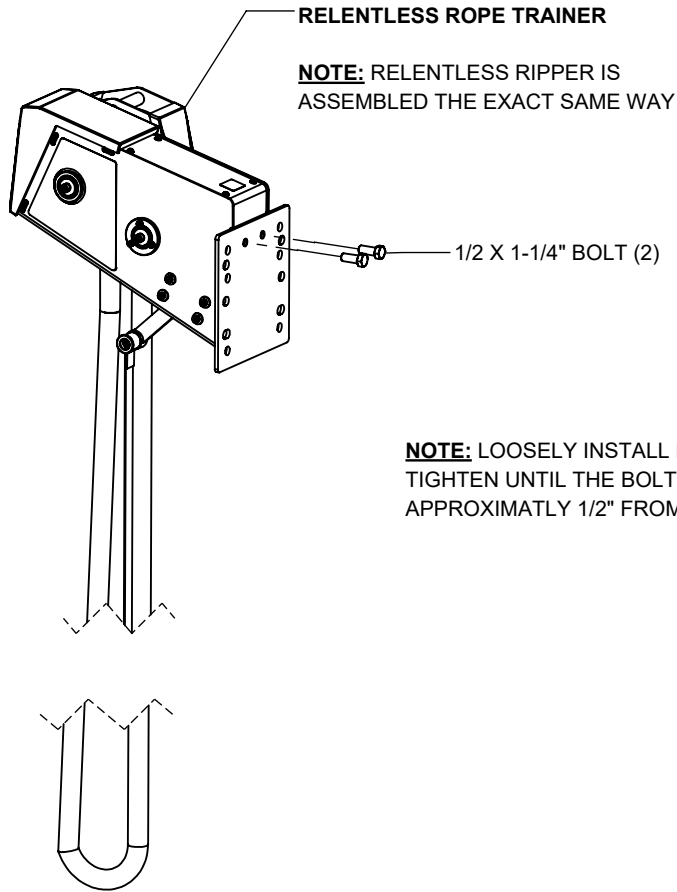

NOTE:

The **Relentless Rope Trainer** is shown, follow the exact same steps to assemble the **Relentless Ripper**.

(**) **HARDWARE COVERS** **CANNOT** be used in place of washers in this step.

XCREATE has been hidden for assembly clarity.

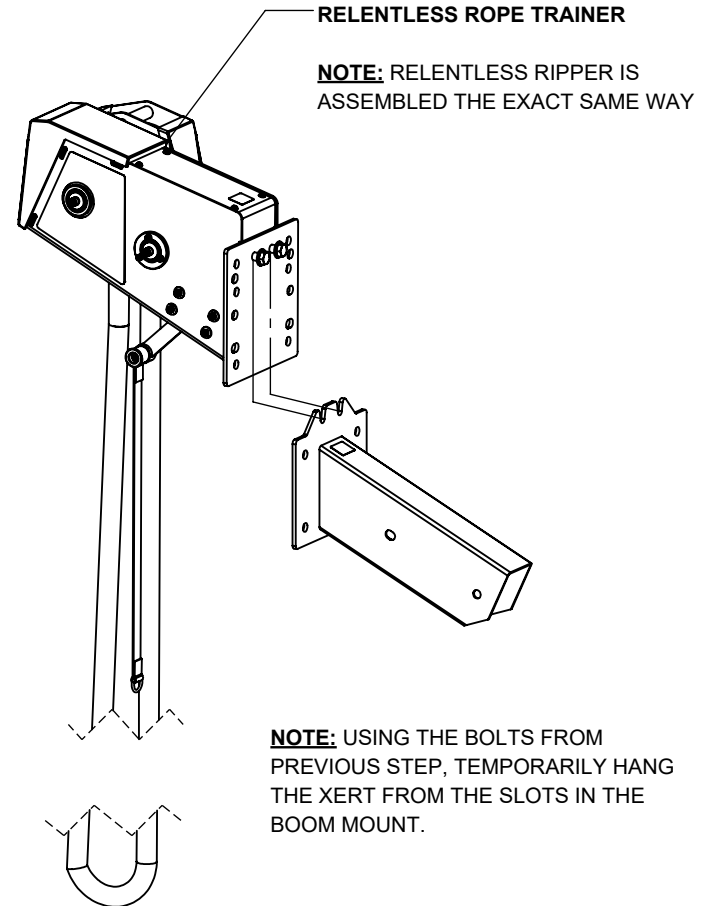

XCREATE-BMXERT RELENTLESS ROPE TRAINER / RELENTLESS RIPPER

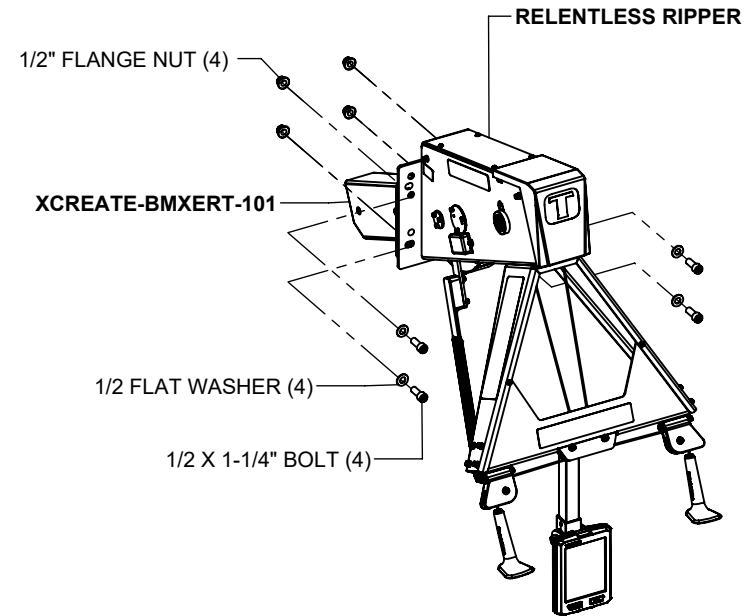
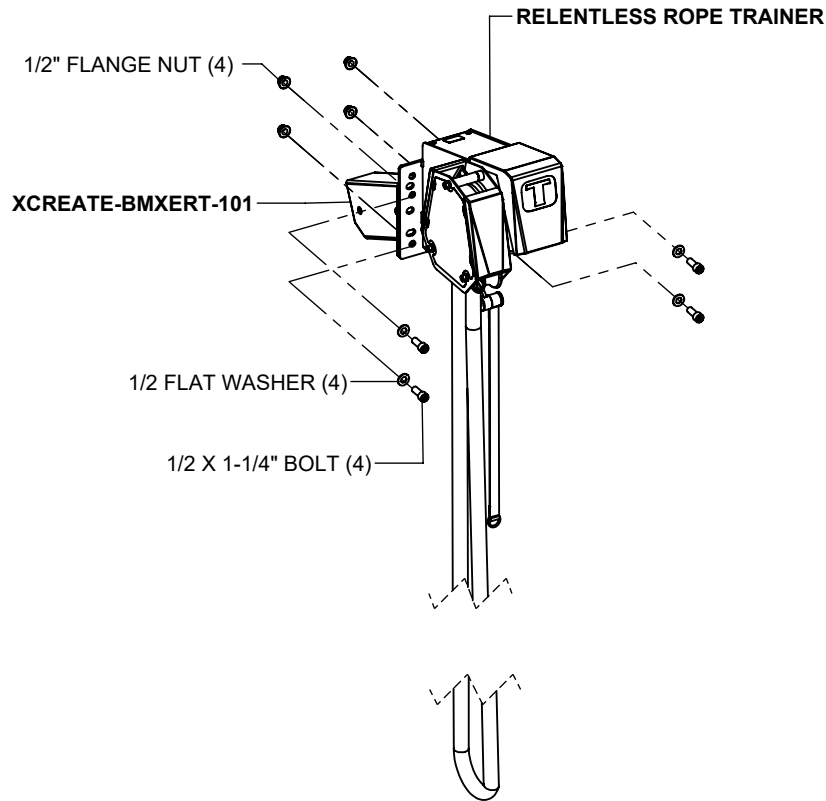

NOTE:

SECURELY tighten all bolt connections in this step, including the bolts from the previous step.

(**) **HARDWARE COVERS CANNOT** be used in place of washers in this step.

XCREATE has been hidden for assembly clarity.

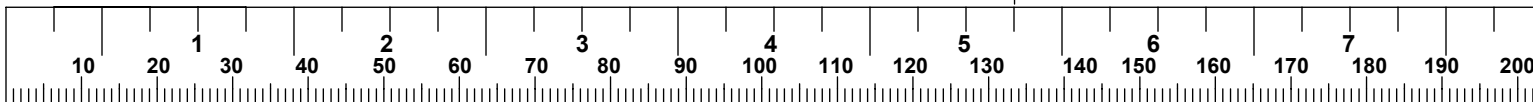

XCREATE-SAM XCREATE SIDE ATTACHMENT MOUNT

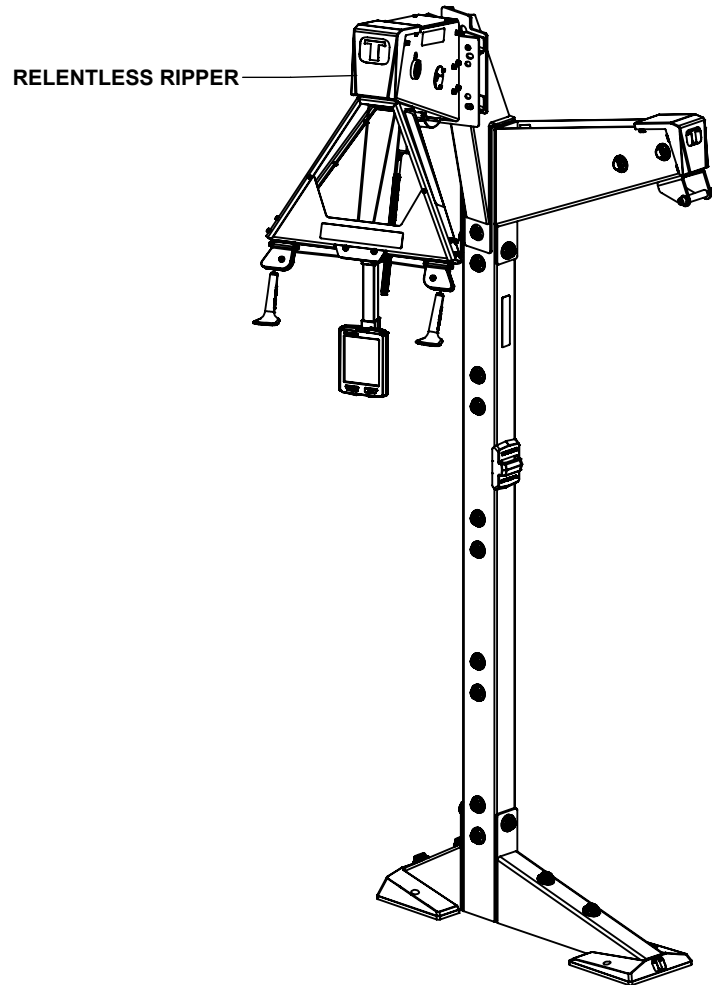

NOTE:

The **Relentless Ripper** is shown, **Relentless Rope** may be assembled the same way.

Assembly instructions for the attachments above are included with the **XCREATE-SAM**.

The instructions can also be downloaded at <https://commercial.torquefitness.com/pages/assembly-manuals>

XCREATE-SAM
SIDE ATTACHMENT MOUNT

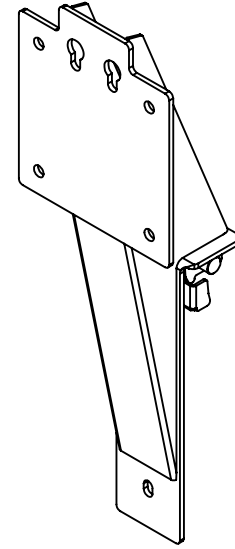

XCREATE-SUW
SINGLE UNIT WEDGE

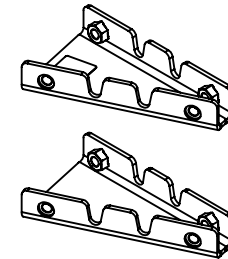

XCREATE-DUW
DOUBLE UNIT WEDGE

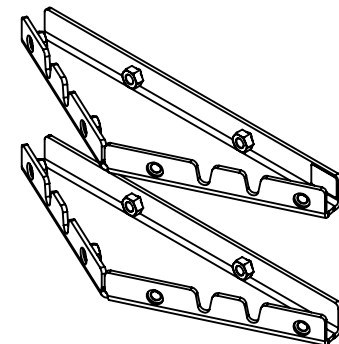

**XCREATE-6RX
RELENTLESS ROPE TRAINER / RELENTLESS RIPPER**

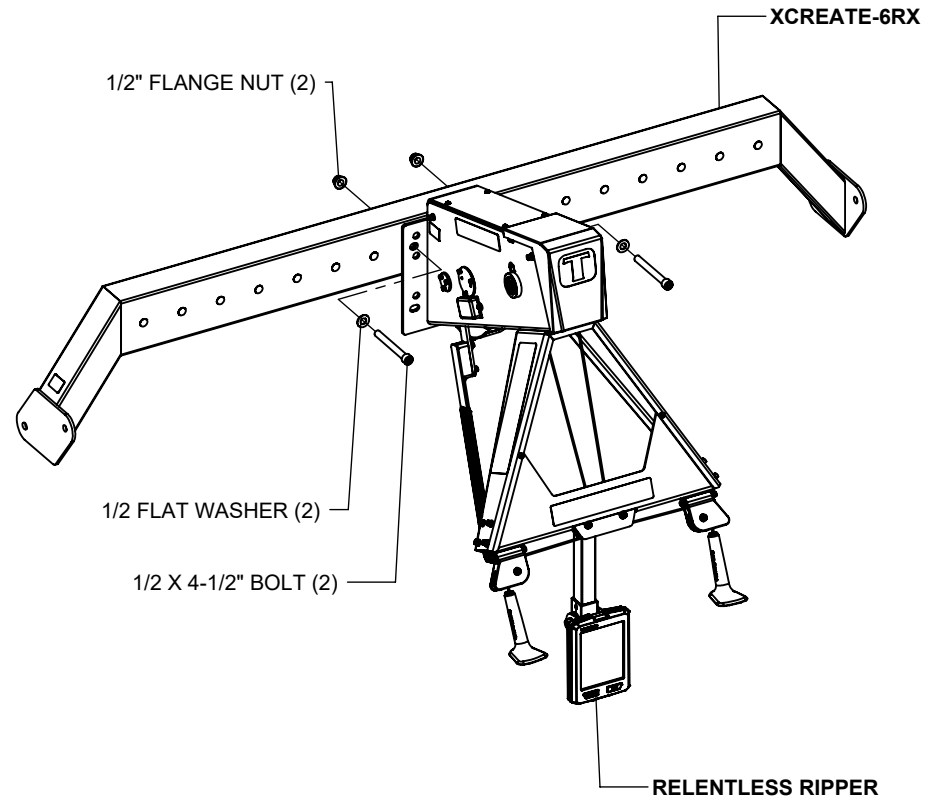
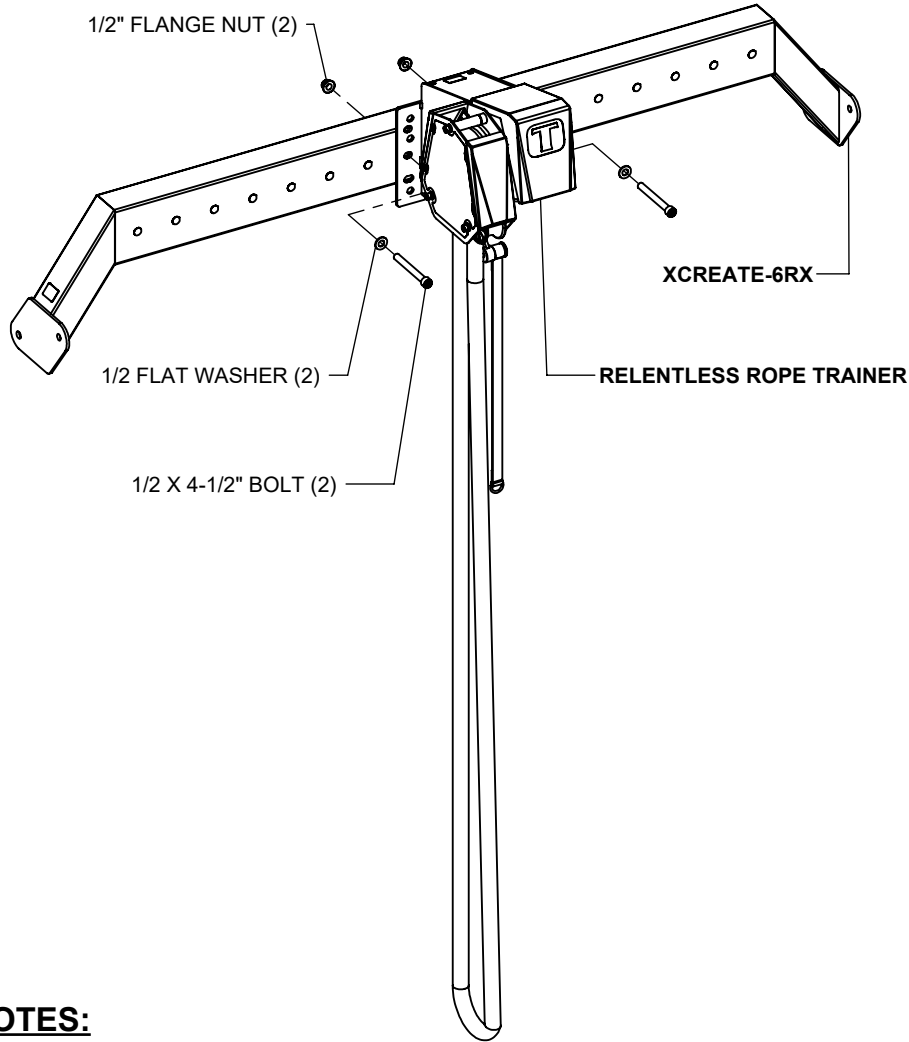

NOTES:

SECURELY tighten all bolt connections in this step.

(**) **HARDWARE COVERS CANNOT** be used in place of washers in this step.

XCREATE uprights have been hidden for assembly clarity

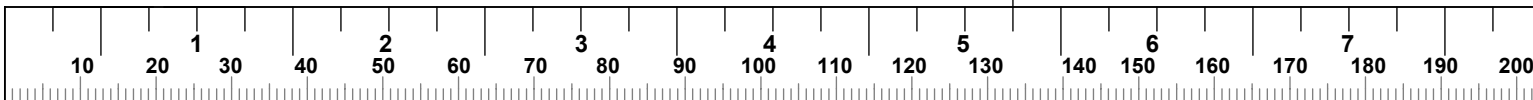

**XCREATE-6RX
BRIDGE BALL TARGET / ROCK CLIMBING KIT**

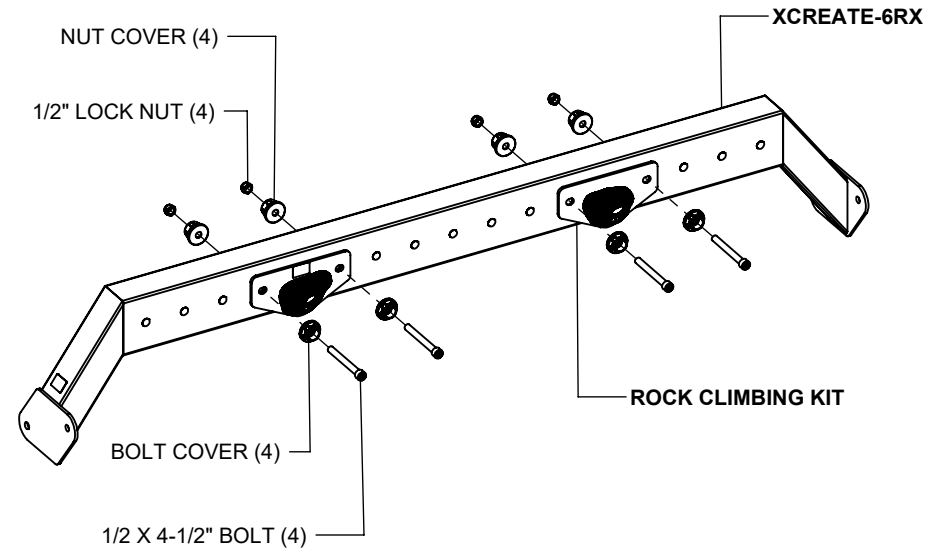
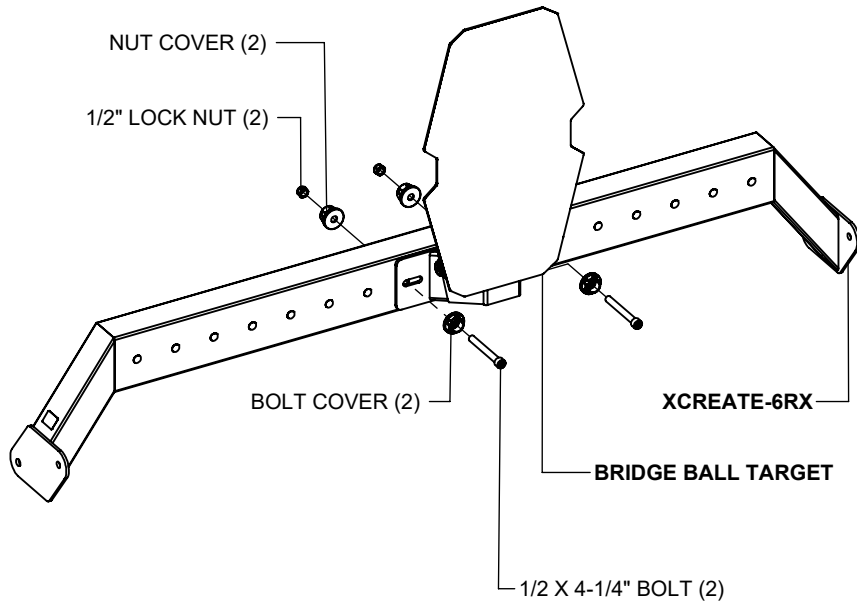

NOTES:

SECURELY tighten all bolt connections in this step.

XCREATE uprights have been hidden for assembly clarity

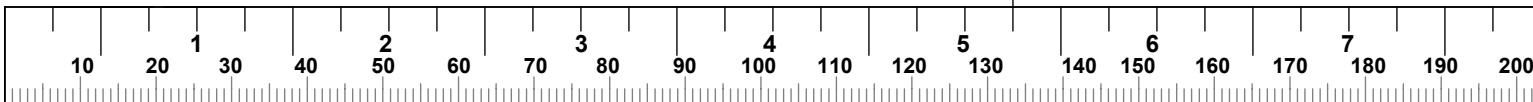

**XCREATE-4WAB
4' WALL ANCHOR BRACKET**

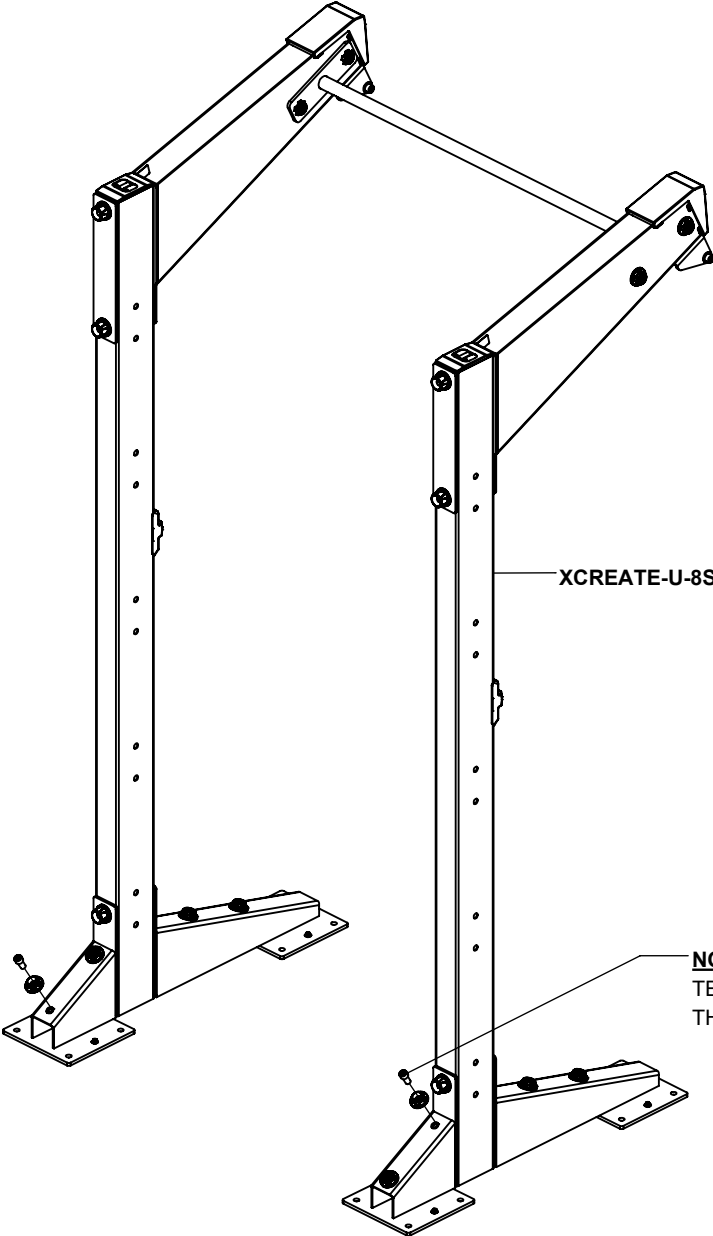

XCREATE-U-8SS

NOTE:
TEMPORARILY REMOVE
THIS BOLT AND WASHER (2)

XCREATE-4WAB
4' WALL ANCHOR BRACKET

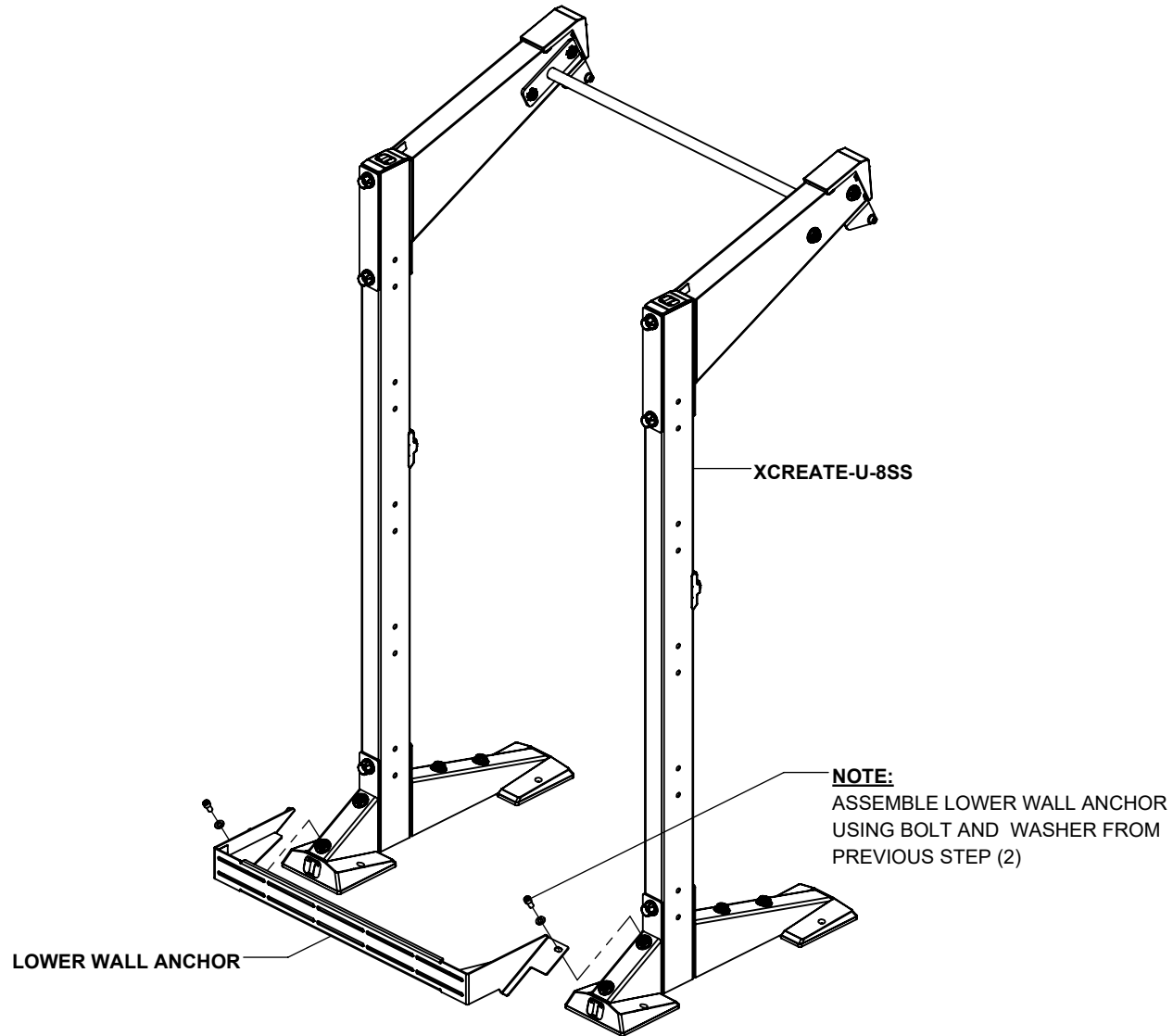

NOTES:

SECURELY assemble bolt connections in this step.

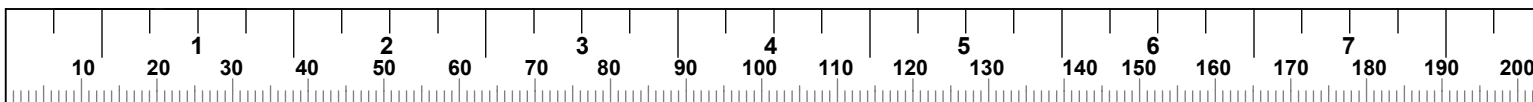

XCREATE-4WAB
4' WALL ANCHOR BRACKET

NOTE:
LOOSEN BUT DO NOT
REMOVE TOP BOLT

NOTE:
REMOVE LOWER
BOLT, ROTATE THE
BACKING PLATE AND
REASSEMBLE.
SECURELY TIGHTEN.

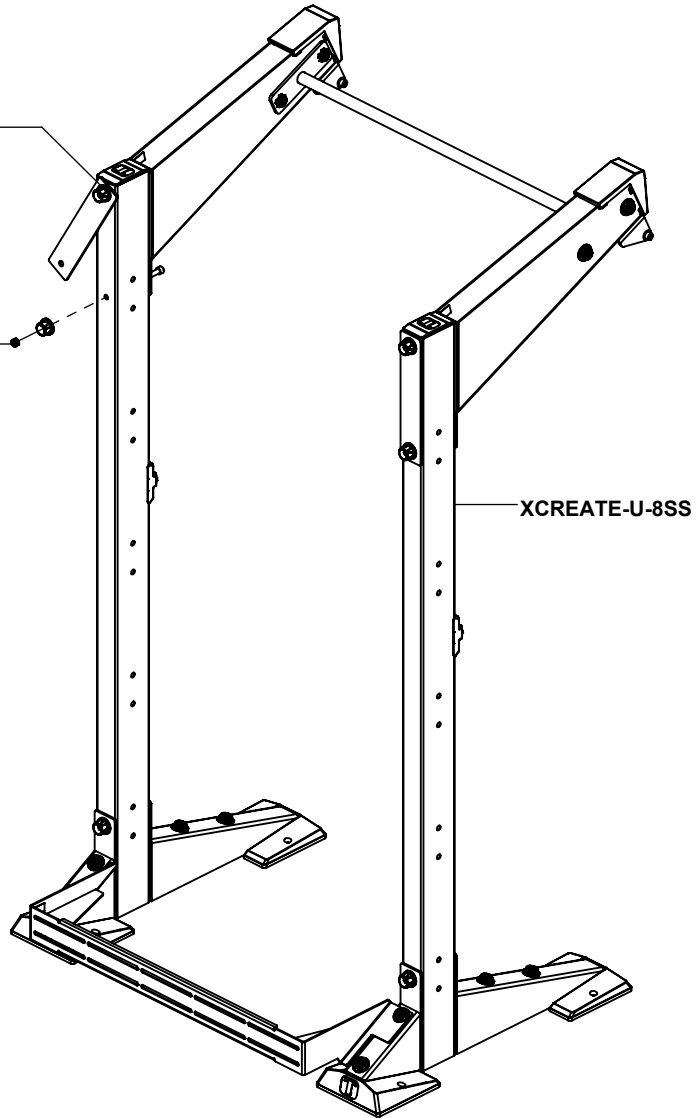

NOTE:
REMOVE AND DISCARD
BACKING PLATE

NOTE:
TEMPORARILY REMOVE
THIS BOLT, WASHER,
HARDWARE COVER AND NUT

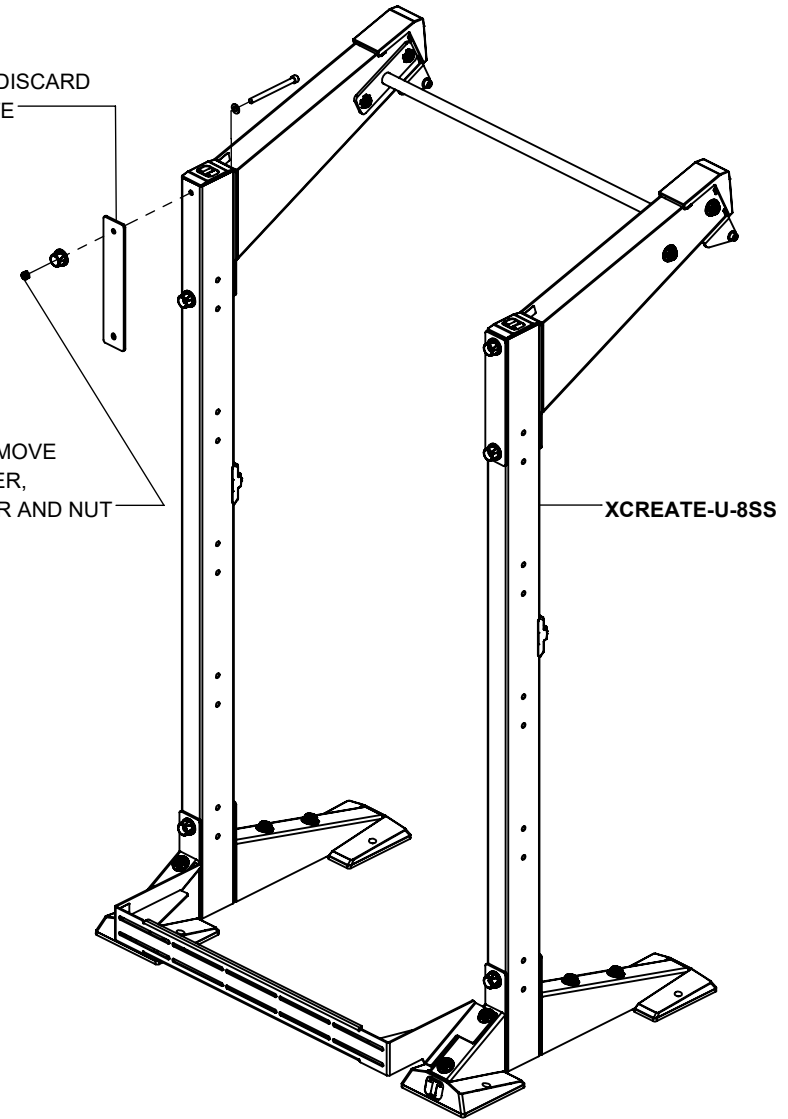

NOTES:

SECURELY assemble bolt connections in this step.

REPEAT THESE STEPS FOR BOTH UPRIGHTS.

XCREATE-4WAB 4' WALL ANCHOR BRACKET

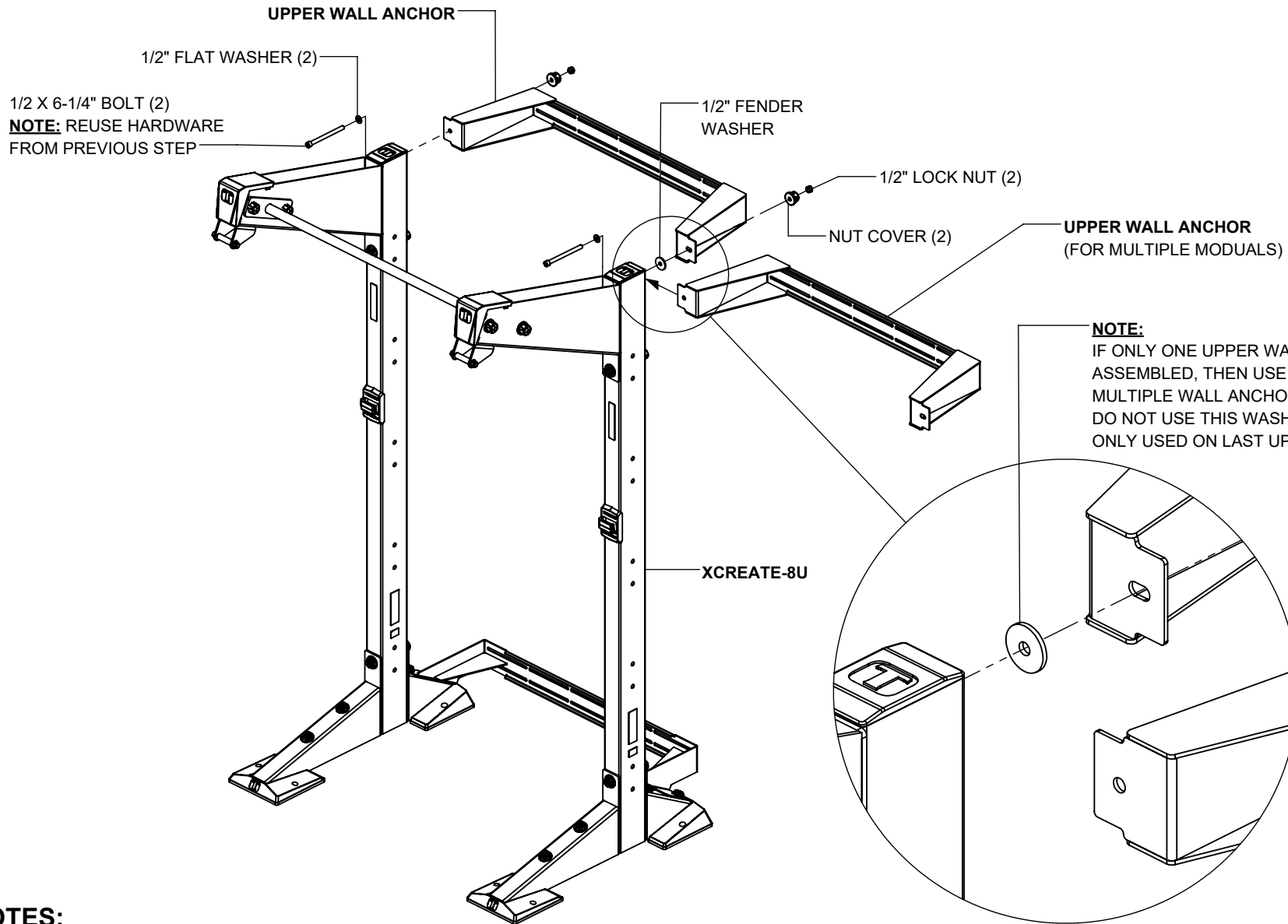

NOTES:

SECURELY assemble bolt connections in this step.

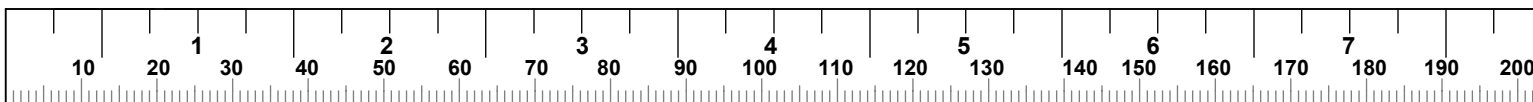

XCREATE-4WAB 4' WALL ANCHOR BRACKET

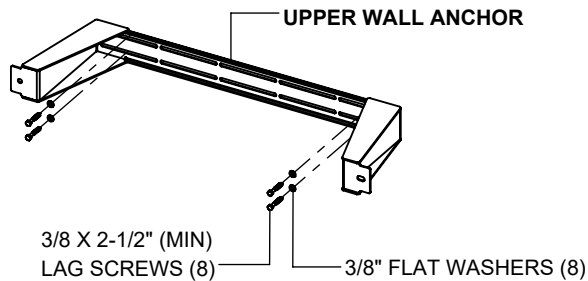

3/8 X 2-1/2" (MIN)
LAG SCREWS (8) 3/8" FLAT WASHERS (8)

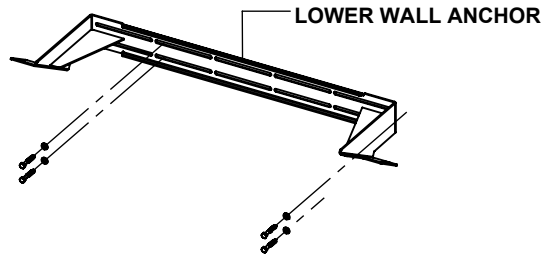

NOTE:
XCREATE HAS BEEN HIDDEN
TO SHOW ANCHORS CLEARLY

NOTES:

The images above show the anchoring hardware used for attaching to typical walls with wood studs spaced 16" on center. The anchors used will depend on the wall construction. **NOTE: At least four anchoring locations must be used in each part.** The pull-out strength of the anchoring bolts used must be greater than or equal to 200 lbs. (91 kg)

SECURELY tighten bolt connections in this step.

WARNING:
THE UPPER WALL ANCHOR MUST BE ANCHORED TO THE WALL USING FOUR WALL ANCHORS SUITABLE FOR THAT PARTICULAR WALL CONSTRUCTION.

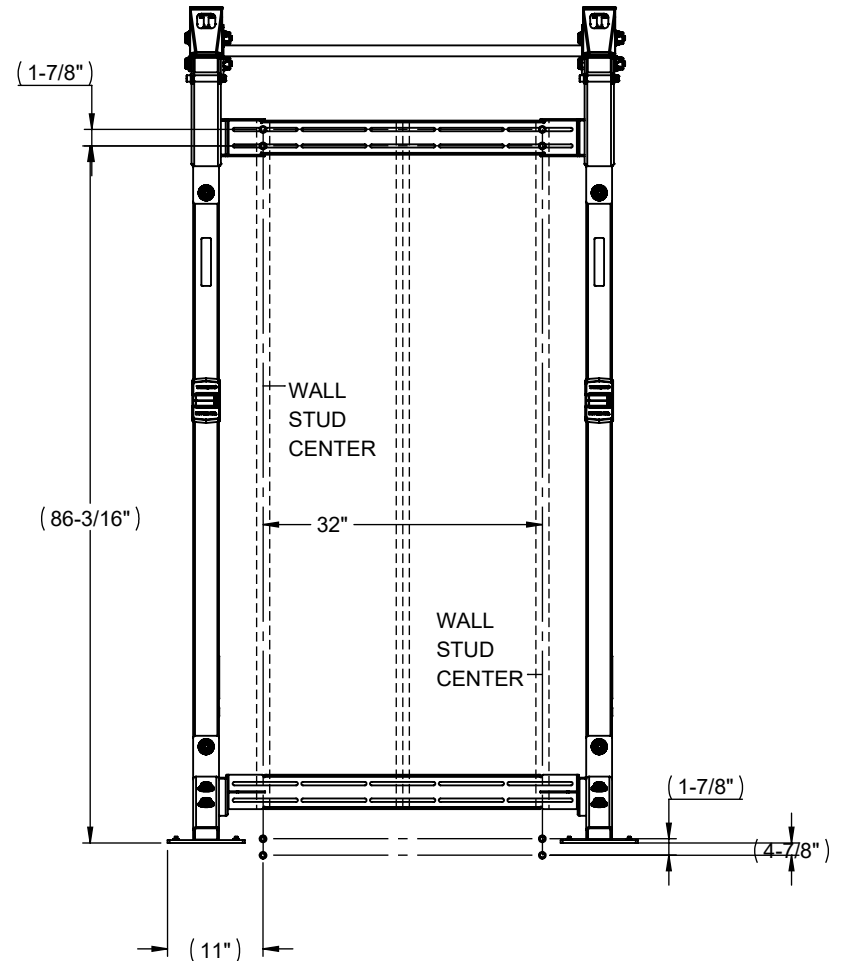

WARNING:
THE LOWER WALL ANCHOR MUST BE ANCHORED TO THE WALL USING FOUR WALL ANCHORS SUITABLE FOR THAT PARTICULAR WALL CONSTRUCTION.

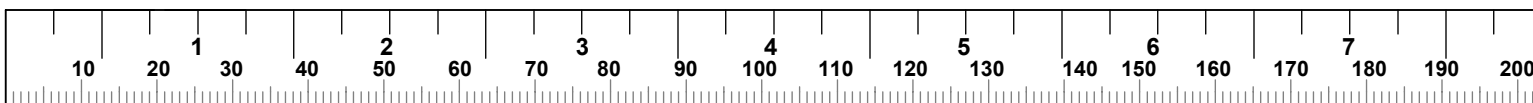

**XCREATE-4CWS
4' COUNTERWEIGHT SUPPORT**

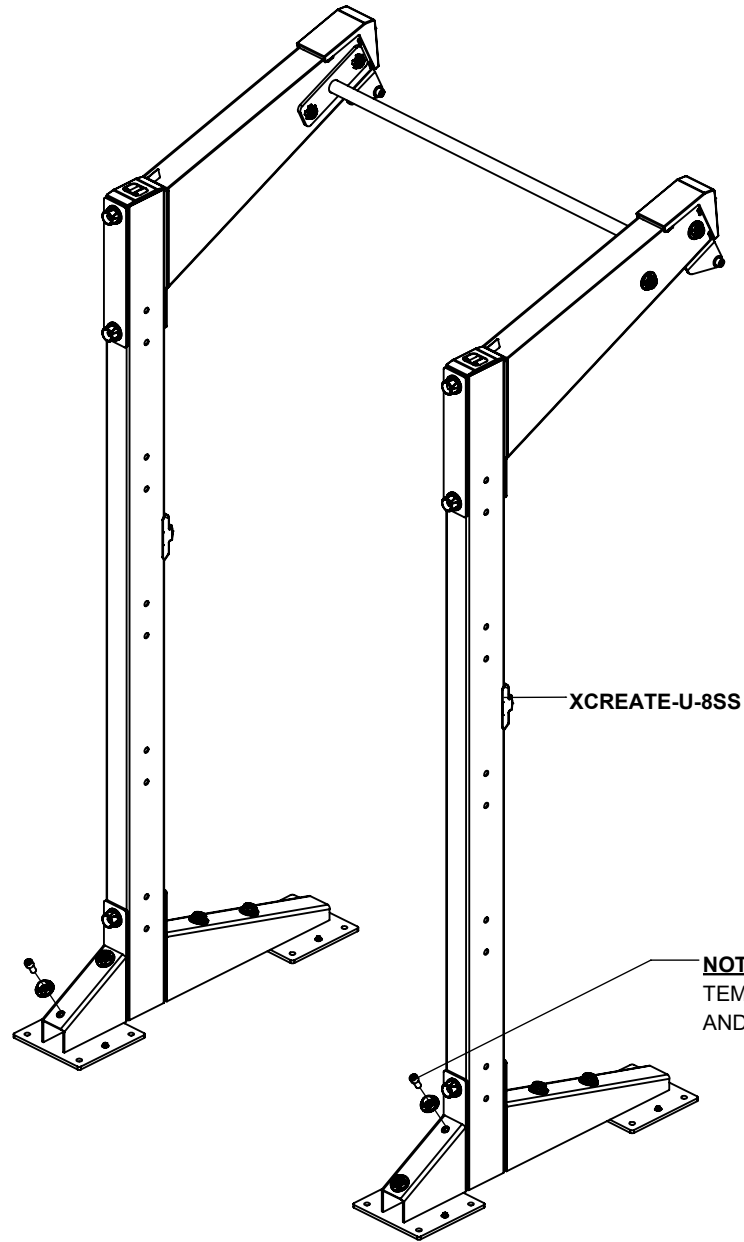

XCREATE-U-8SS

NOTE:
TEMPORARILY REMOVE BOLTS
AND HARDWARE COVERS (2)

XCREATE-4CWS **4' COUNTERWEIGHT SUPPORT**

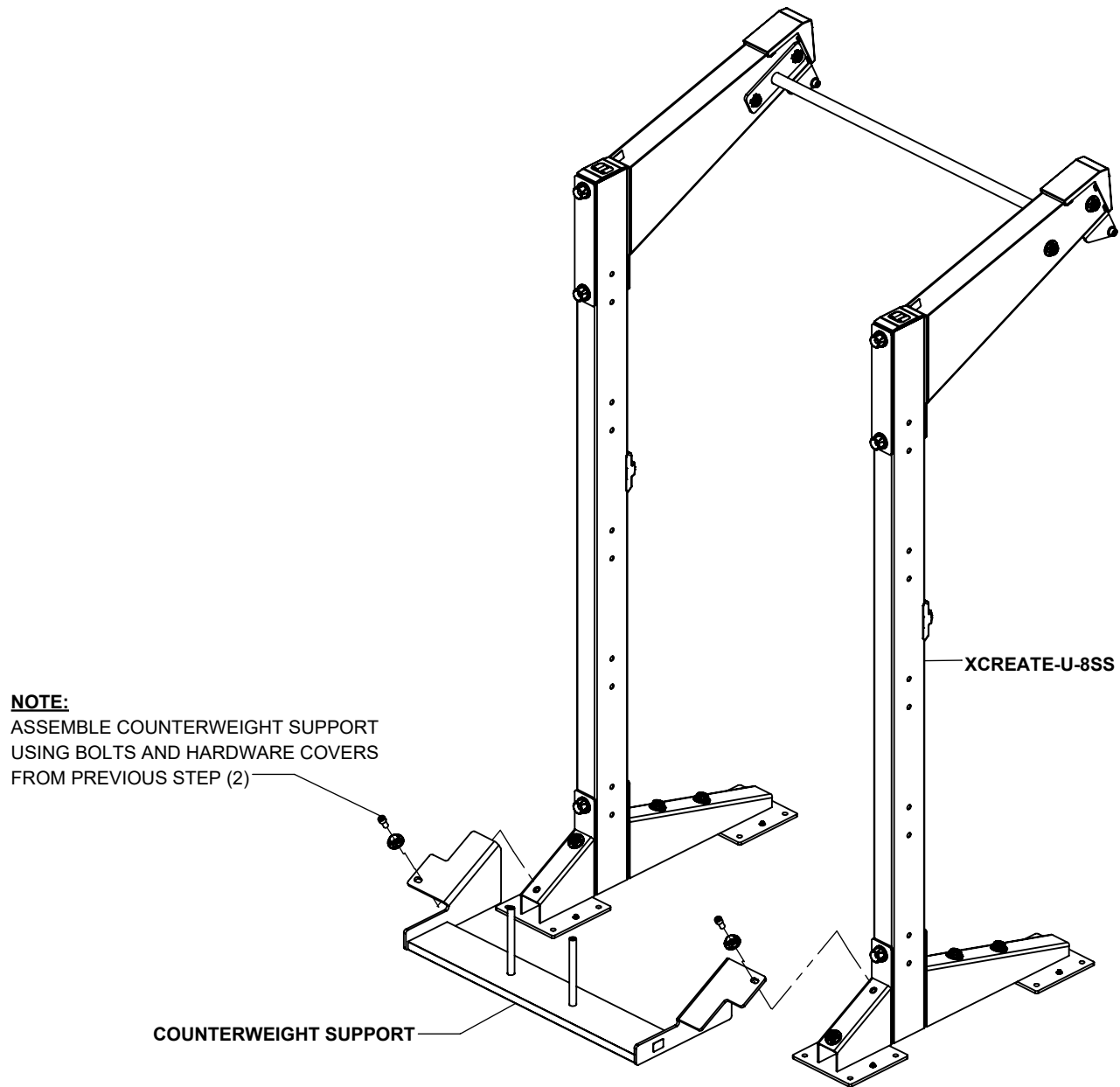

NOTES:

SECURELY assemble bolt connections in this step.

The **XCREATE-U-7SS** is assembled the exact same way.

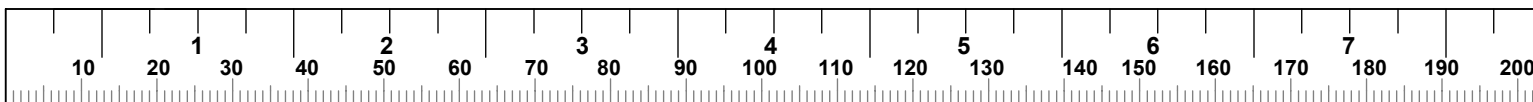

XCREATE-4CWS
4' COUNTERWEIGHT SUPPORT

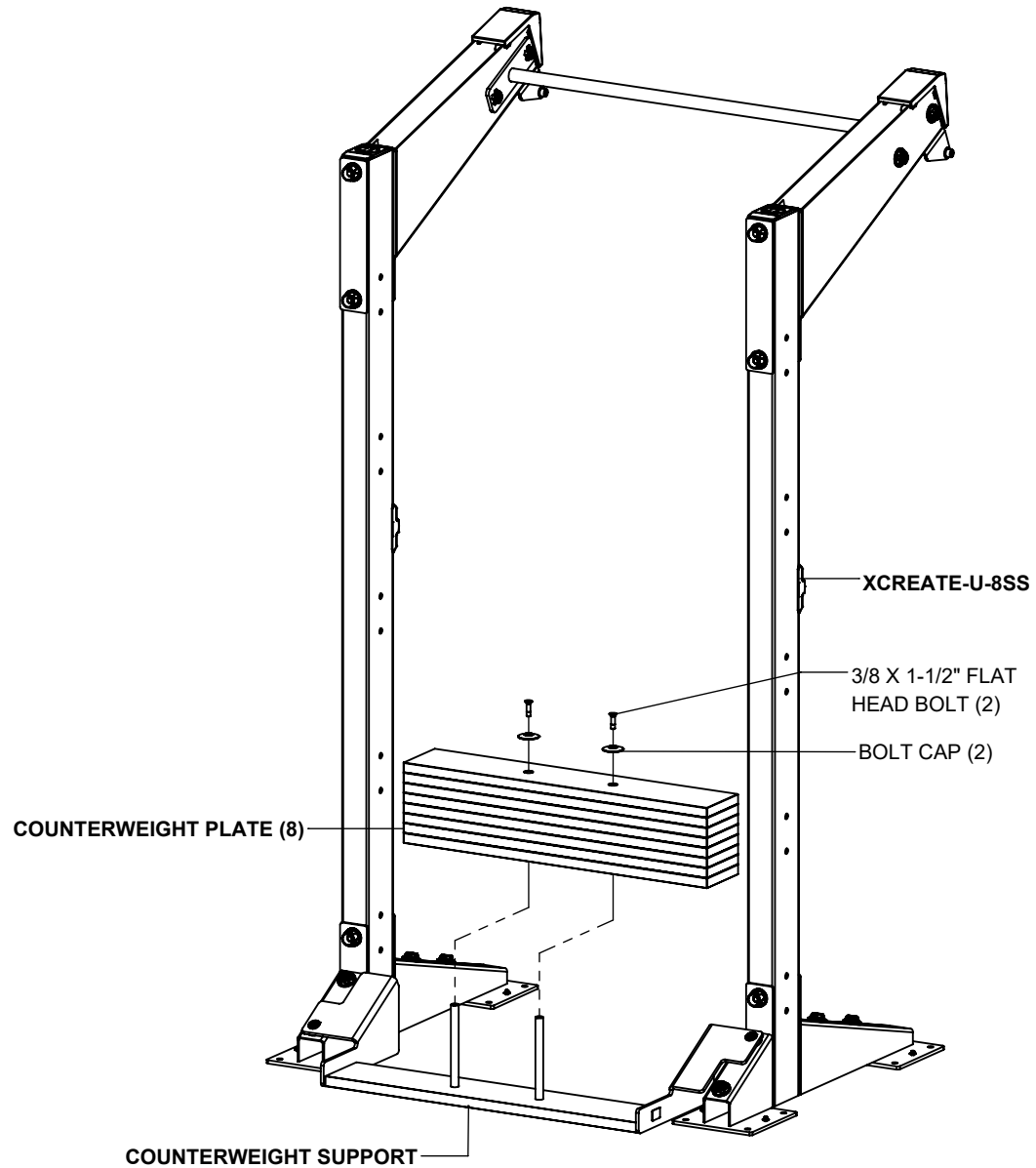

NOTES:

SECURELY assemble bolt connections in this step.

The **XCREATE-U-7SS** is assembled the exact same way.

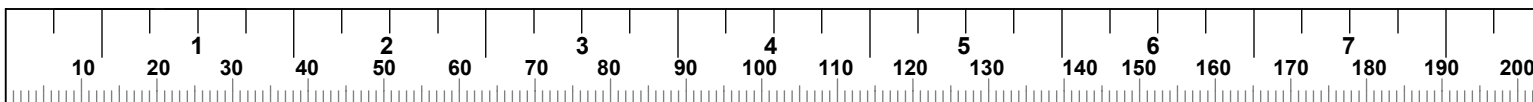

XCREATE-6CWS
6' COUNTERWEIGHT SUPPORT

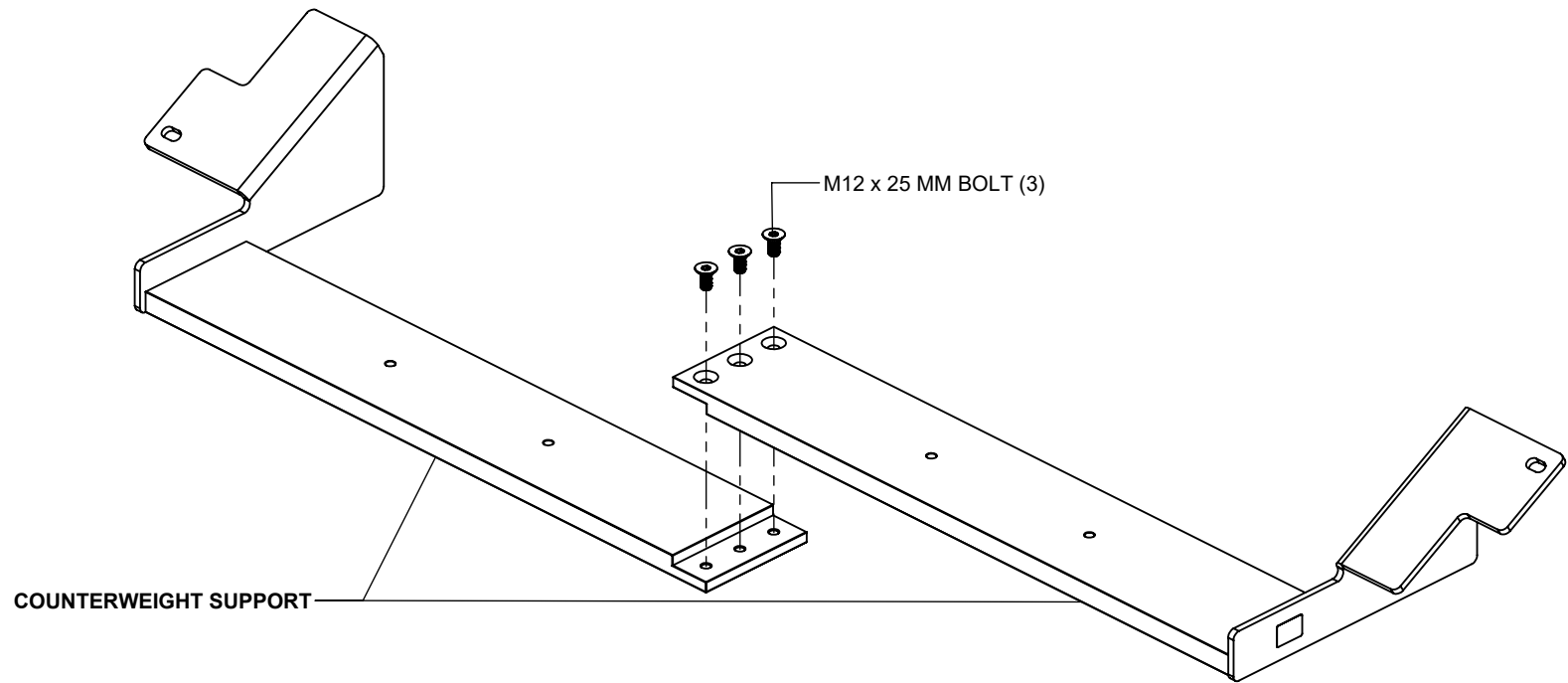

NOTES:

SECURELY assemble bolt connections in this step.

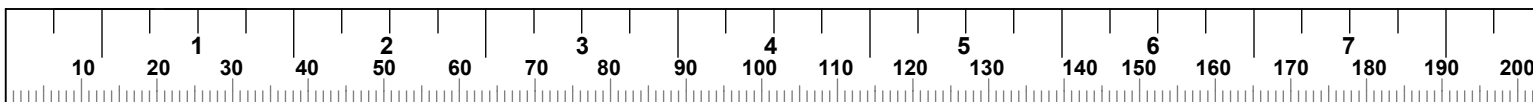

**XCREATE-6CWS
6' COUNTERWEIGHT SUPPORT**

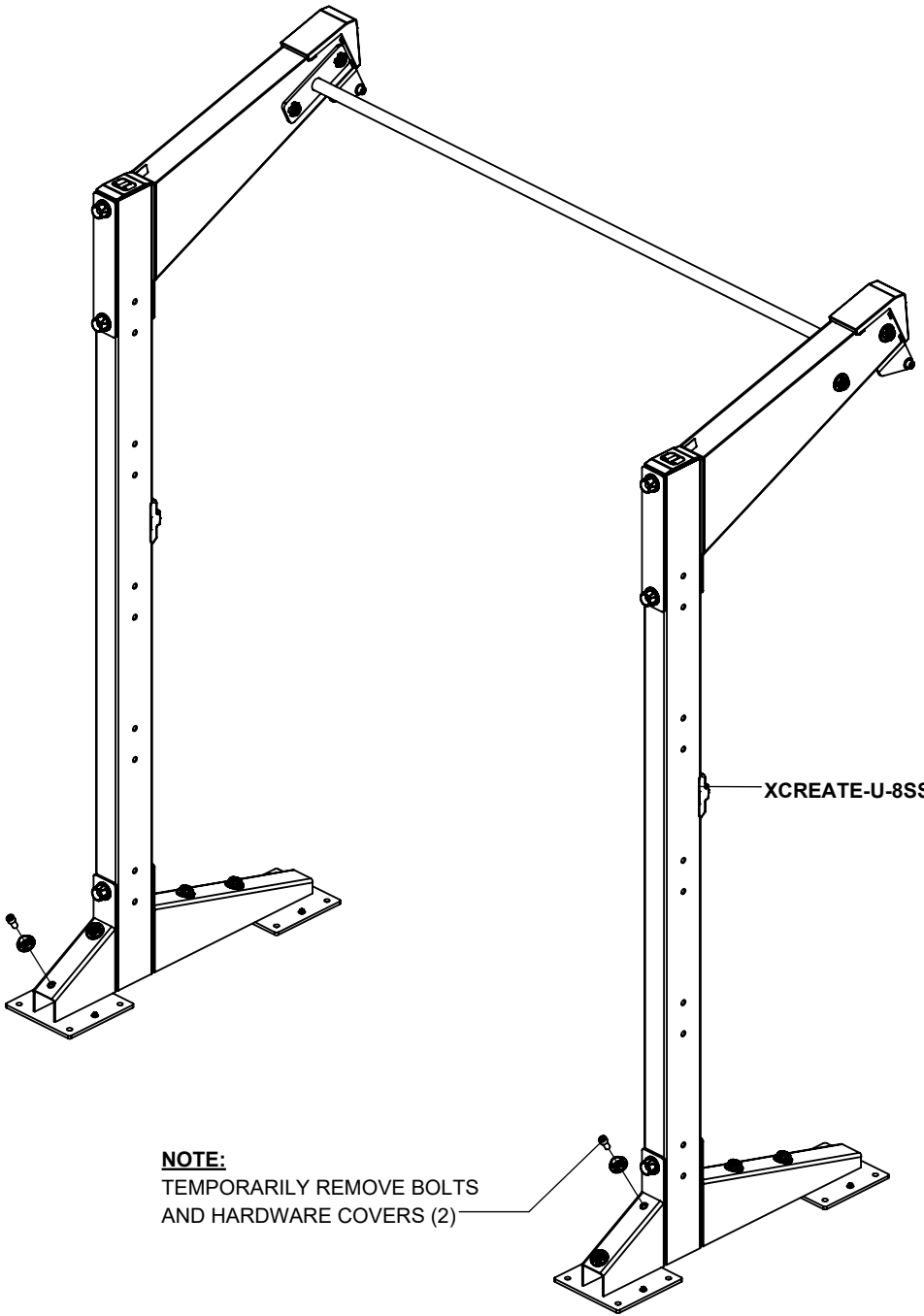

NOTE:
TEMPORARILY REMOVE BOLTS
AND HARDWARE COVERS (2)

XCREATE-6CWS **6' COUNTERWEIGHT SUPPORT**

NOTE:

ASSEMBLE COUNTERWEIGHT SUPPORT
USING BOLTS AND HARDWARE COVERS
FROM PREVIOUS STEP (2)

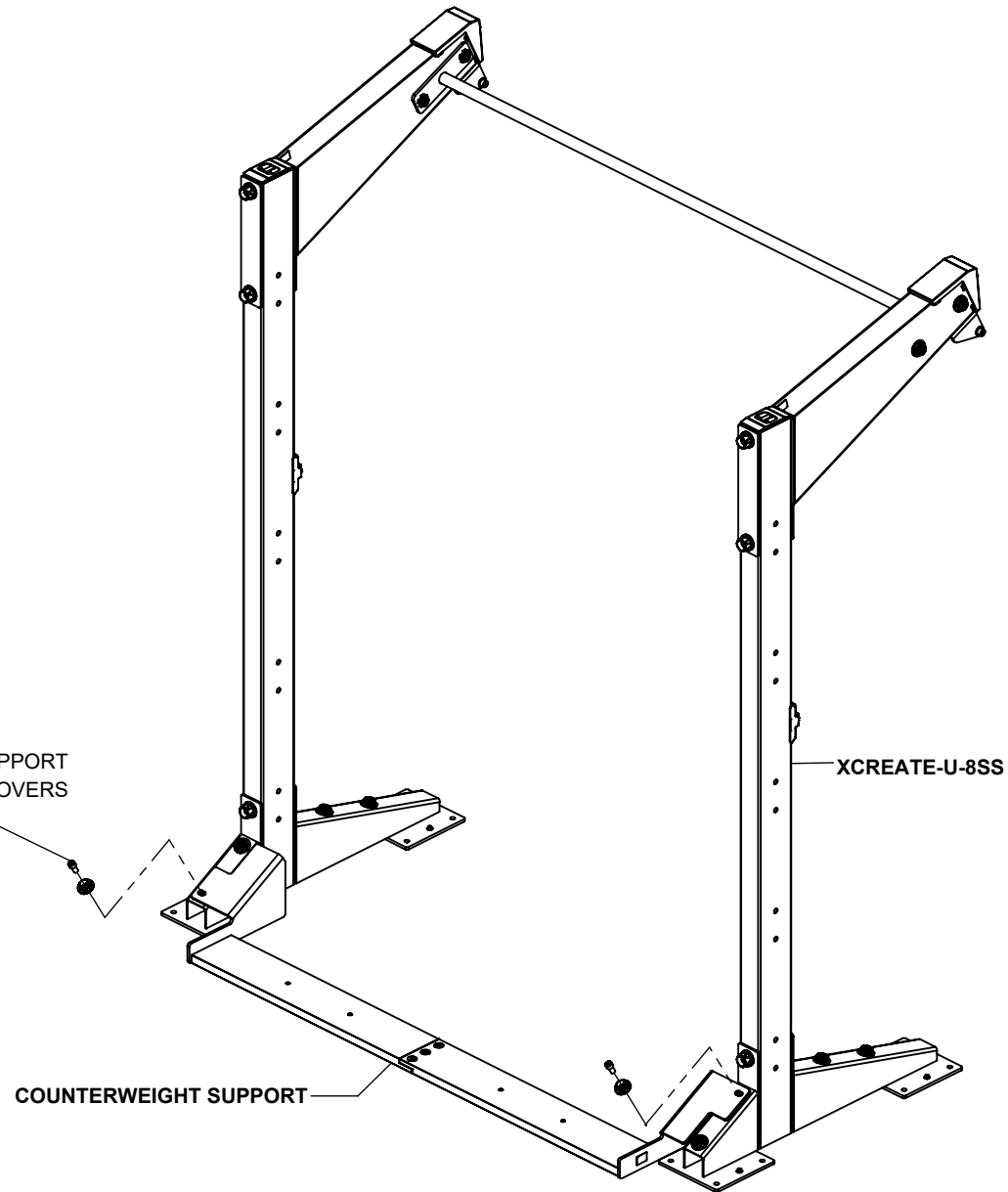

NOTES:

SECURELY assemble bolt connections in this step.

The **XCREATE-U-7SS** is assembled the exact same way.

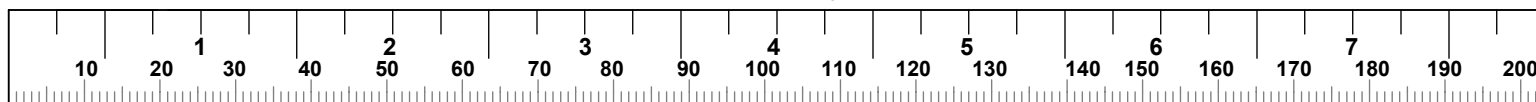

XCREATE-6CWS **6' COUNTERWEIGHT SUPPORT**

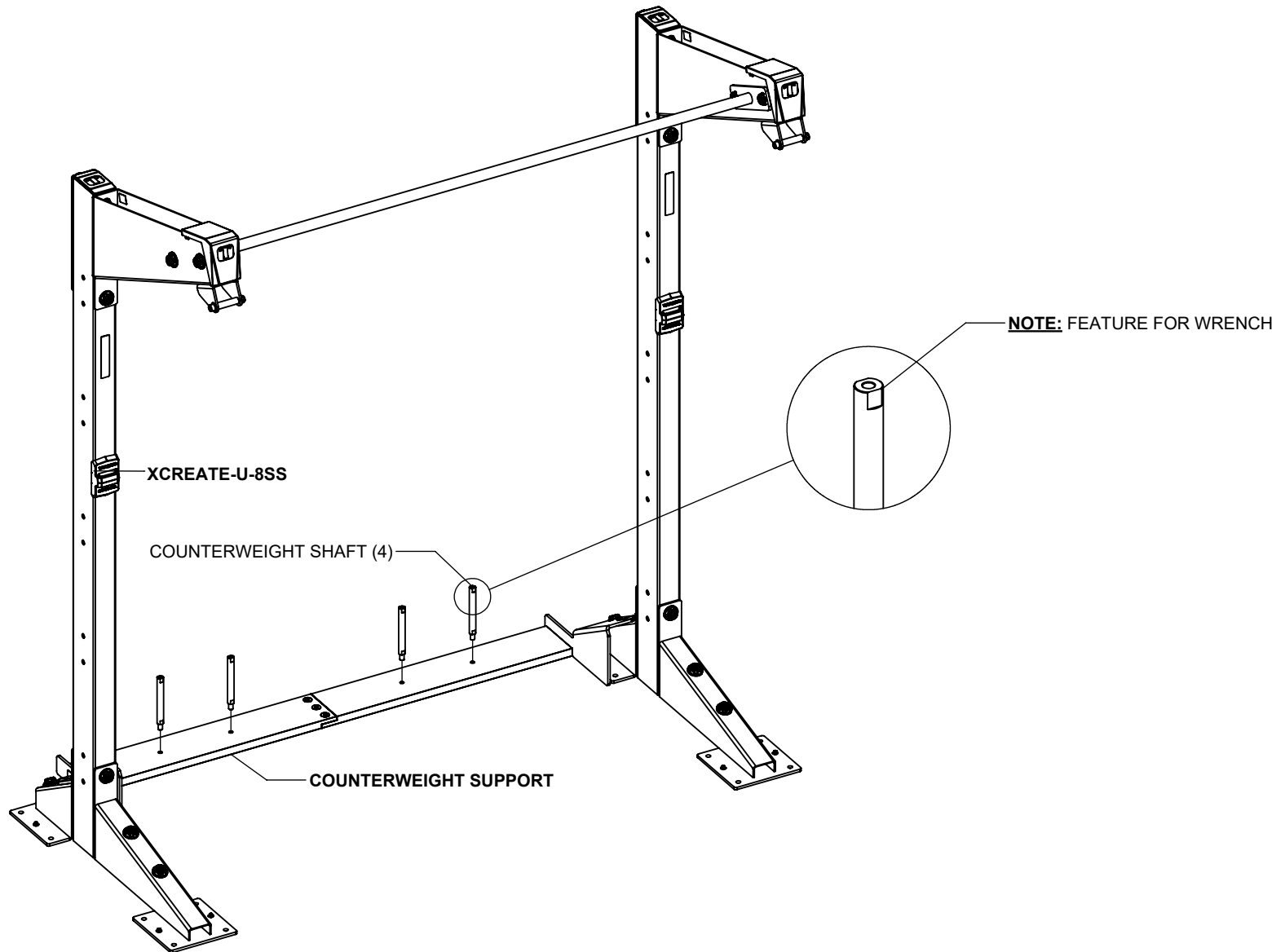

NOTES:

SECURELY assemble bolt connections in this step.

The **XCREATE-U-7SS** is assembled the exact same way.

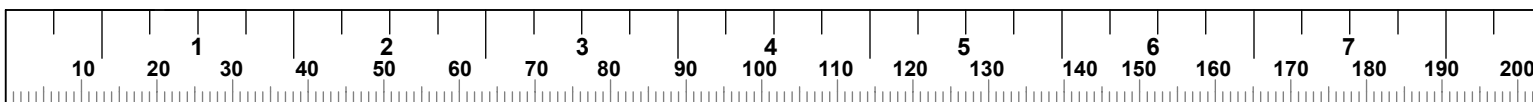

XCREATE-6CWS
6' COUNTERWEIGHT SUPPORT

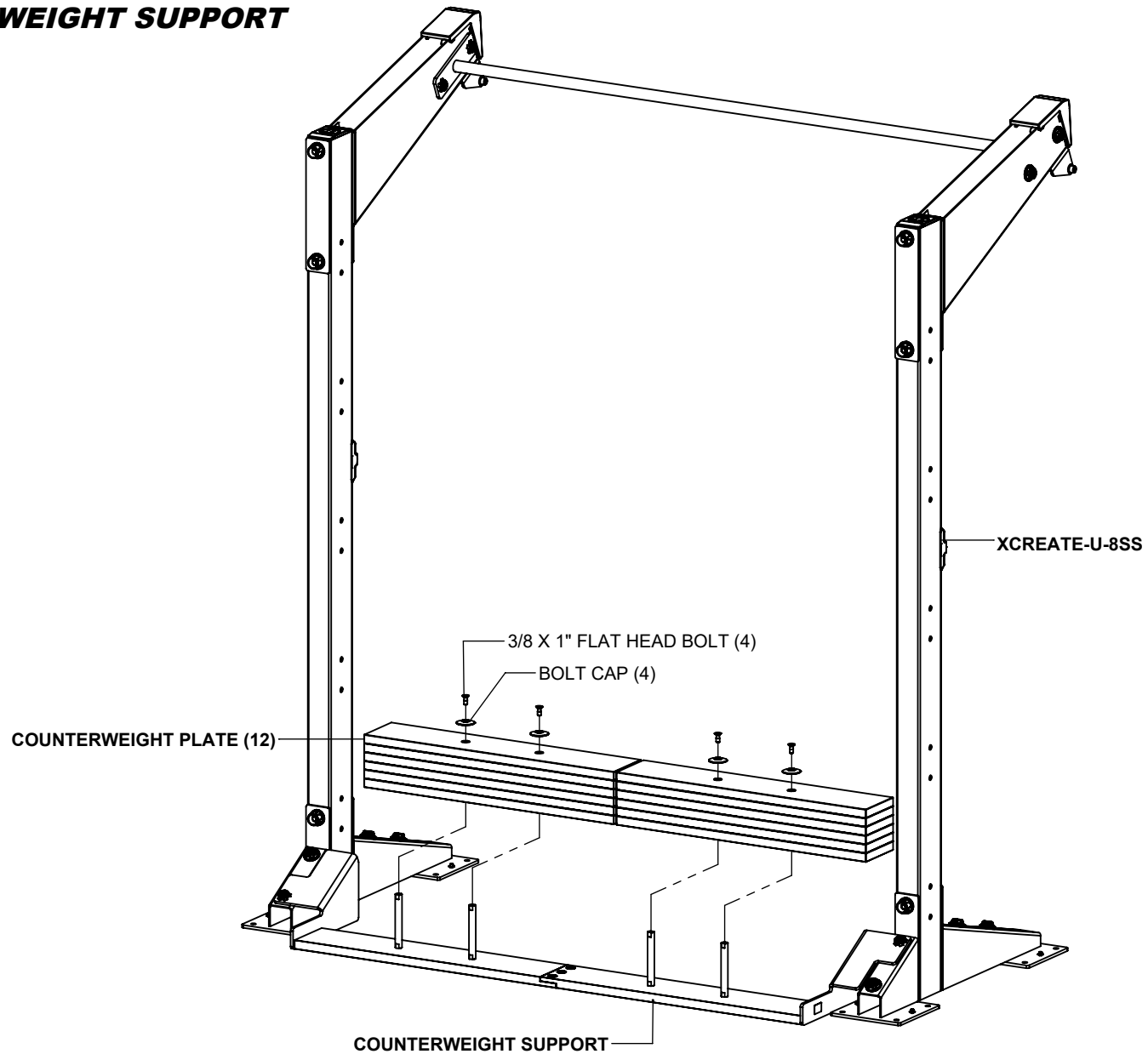

NOTES:

SECURELY assemble bolt connections in this step.

The **XCREATE-U-7SS** is assembled the exact same way.

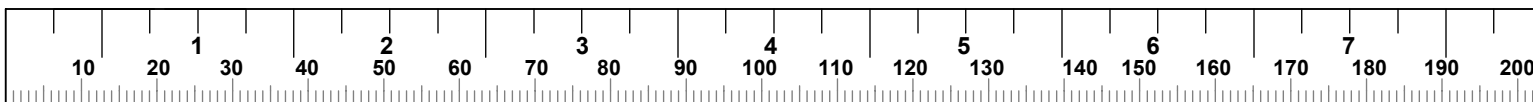

**XCREATE-OR
OUTRIGGER**

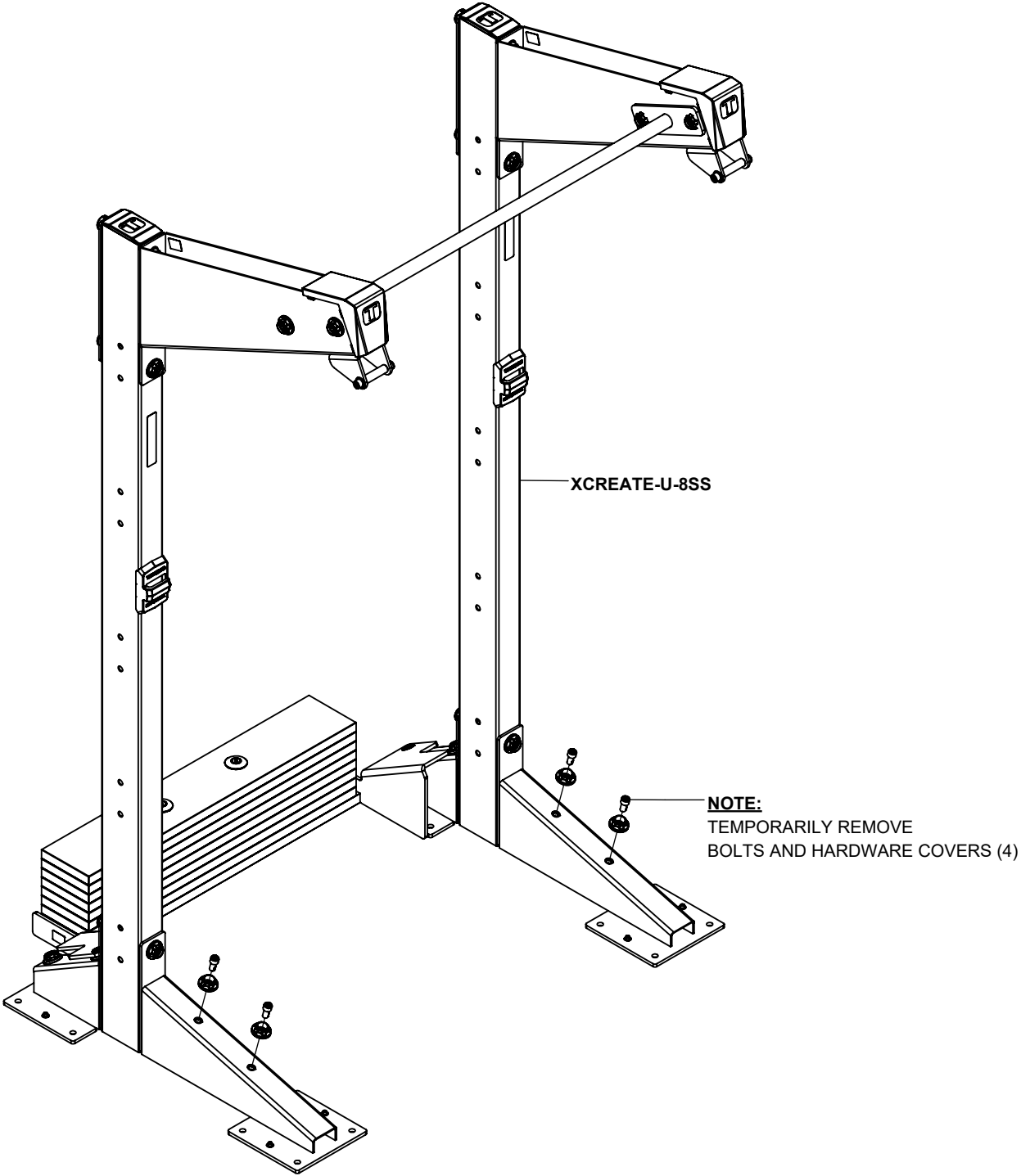

XCREATE-OR OUTRIGGER

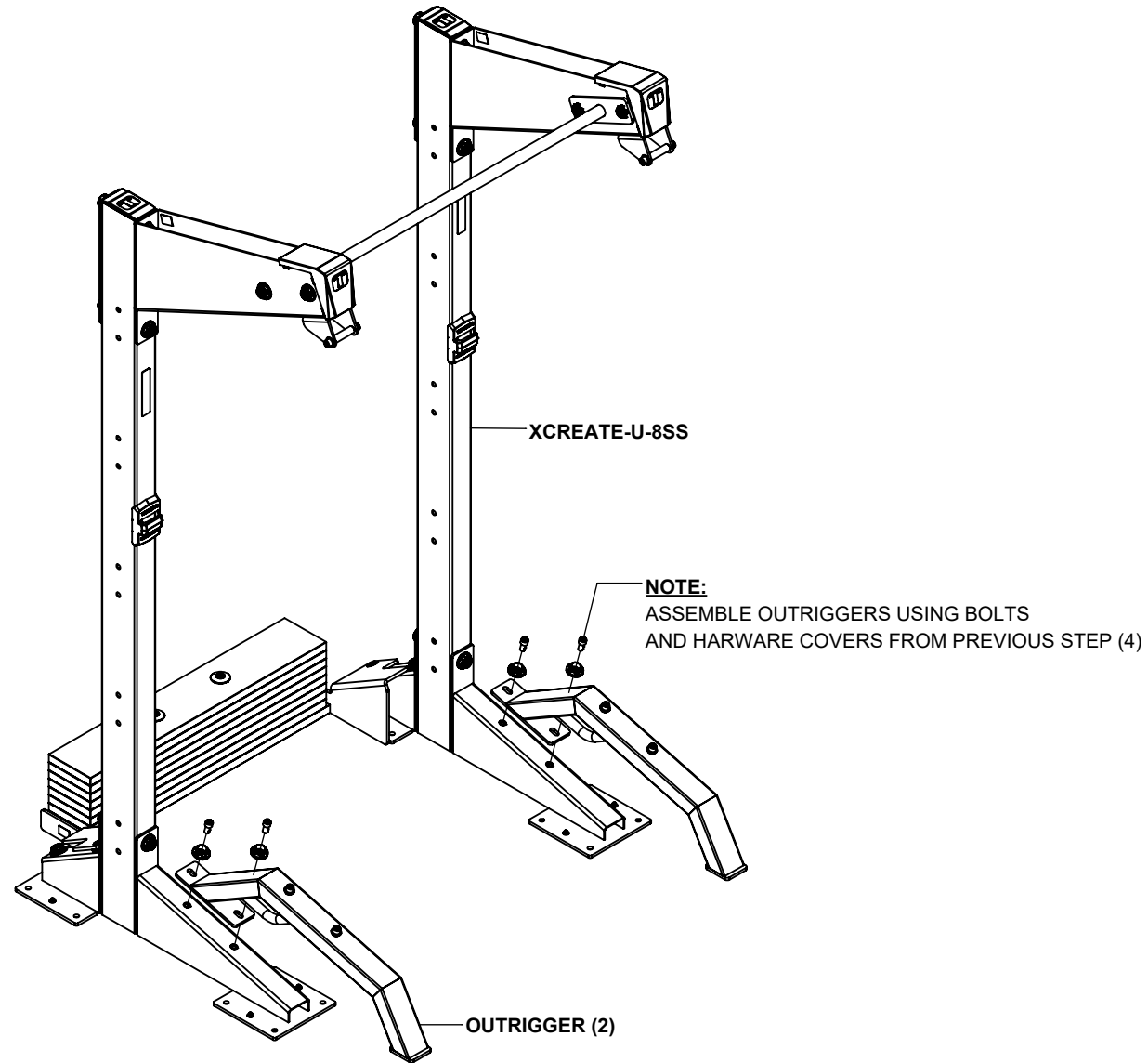

NOTES:

SECURELY assemble bolt connections in this step.

The **XCREATE-U-7SS** is assembled the exact same way.

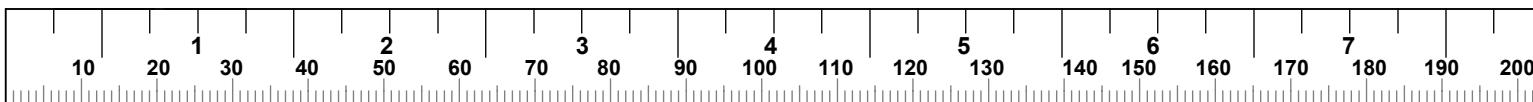

XCREATE-SA-BOSU BOSU STORAGE ATTACHMENT

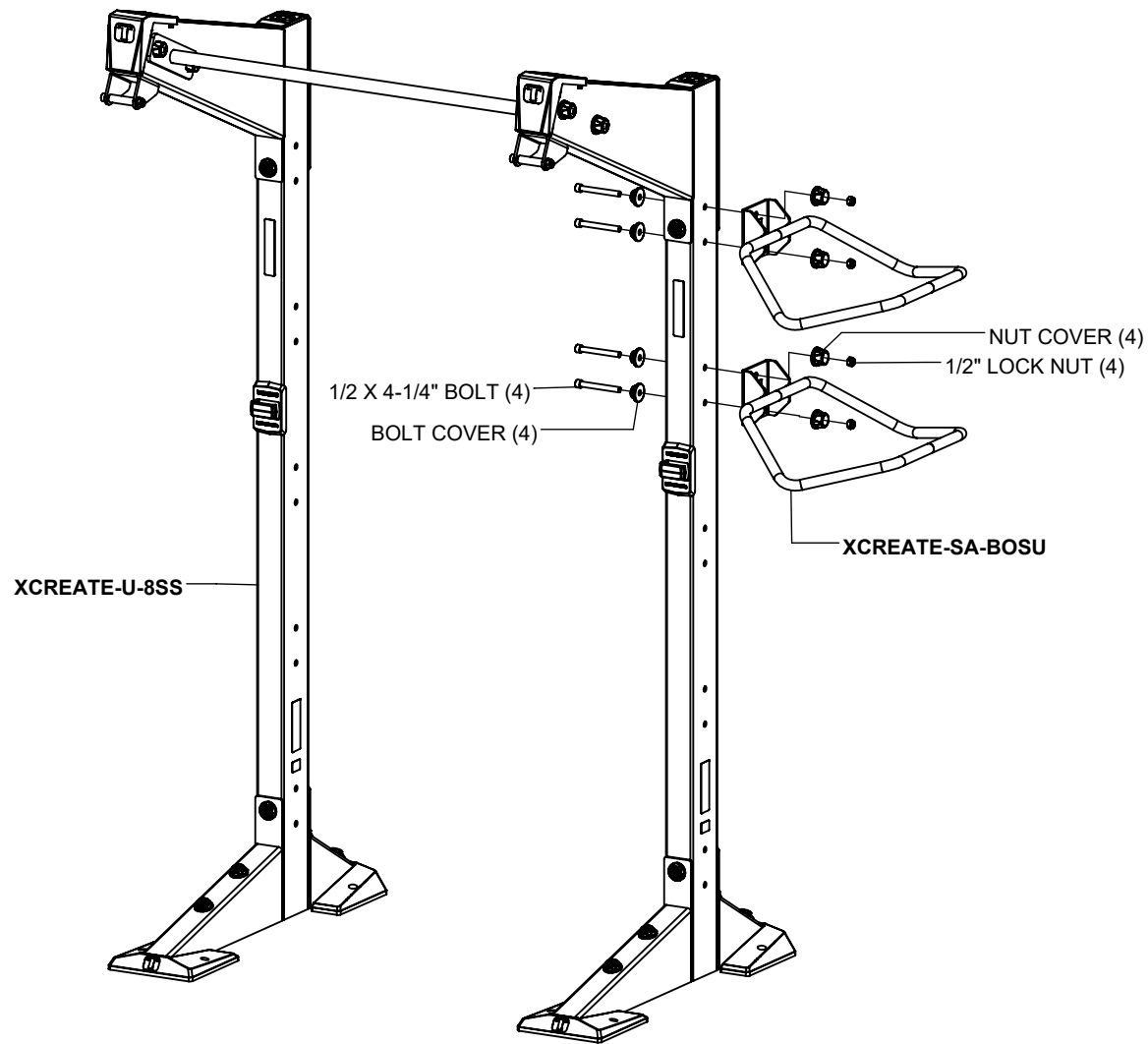

NOTES:

SECURELY tighten all bolt connections in this step.

The **XCREATE-U-7SS** is assembled the exact same way.

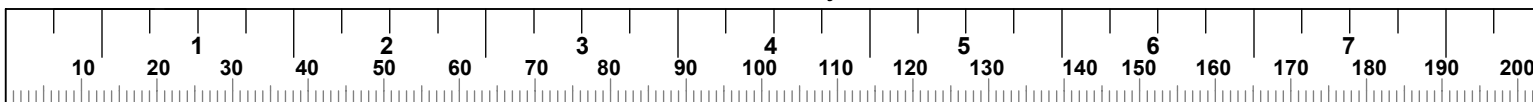

**XCREATE-FRS6-8
FOAM ROLLER STORAGE ATTACHMENT**

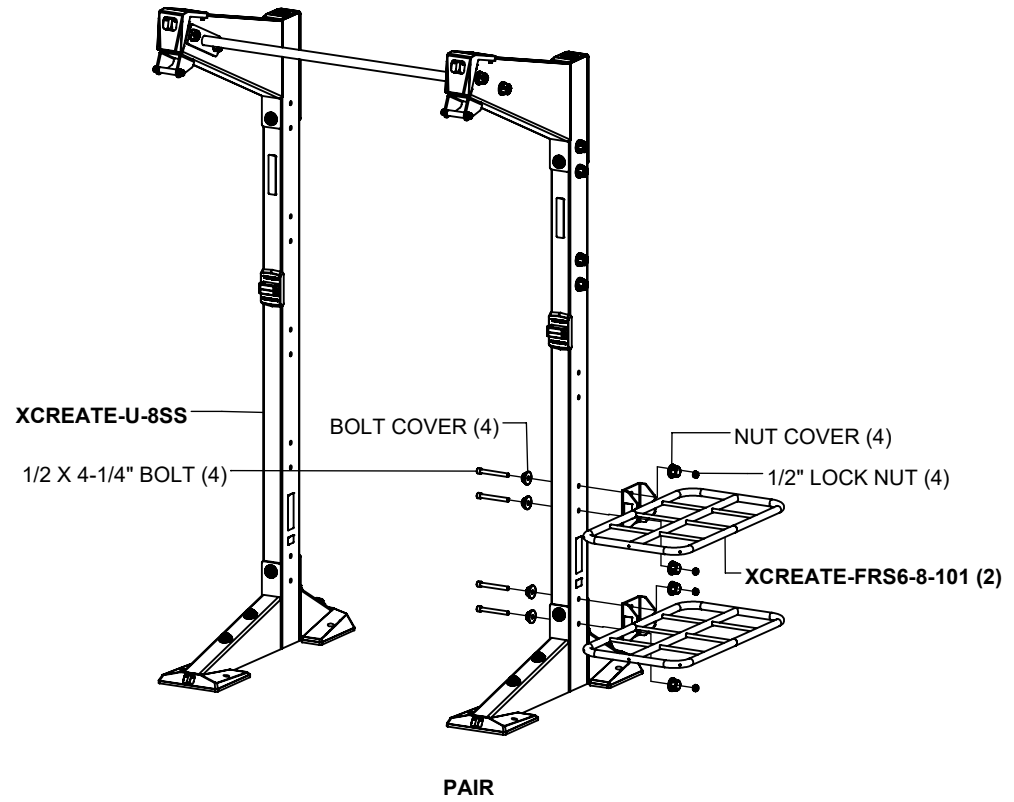
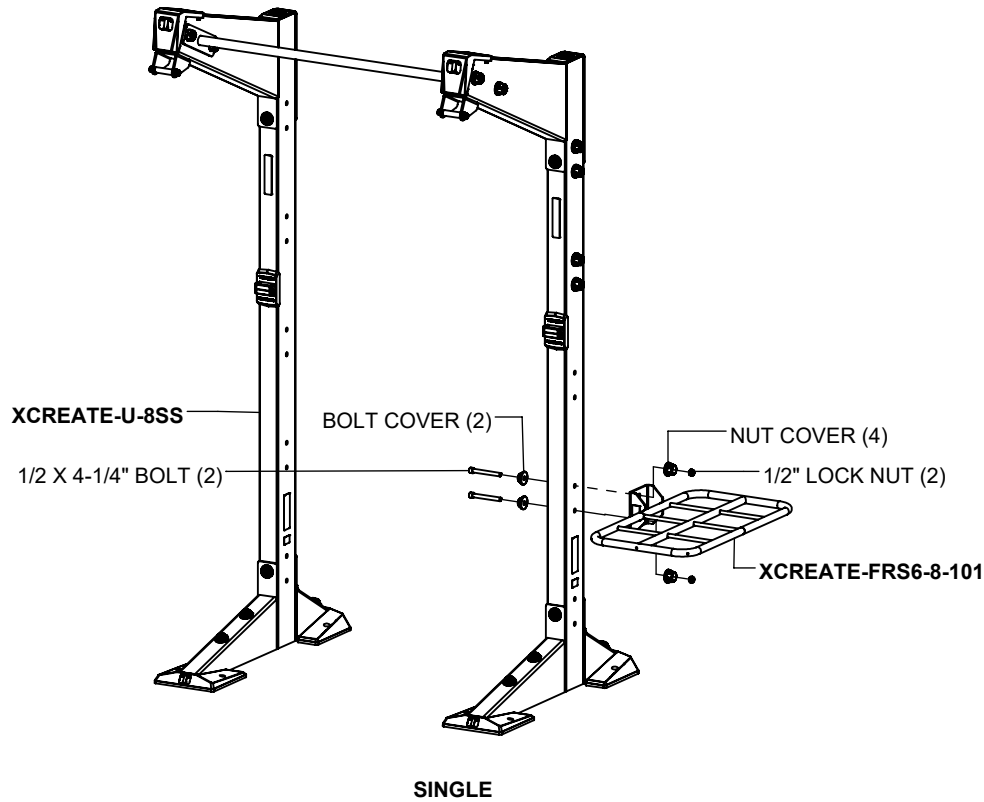

NOTES:

Assembly steps show a single and pair. For additional foam roller stability a pair is recommended.

LEVEL ATTACHMENT AND SECURELY tighten all bolt connections in this step.

The **XCREATE-U-7SS** is assembled the exact same way.

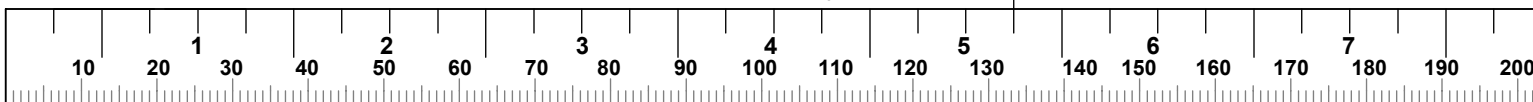

XCREATE-FRS6-8 FOAM ROLLER STORAGE ATTACHMENT

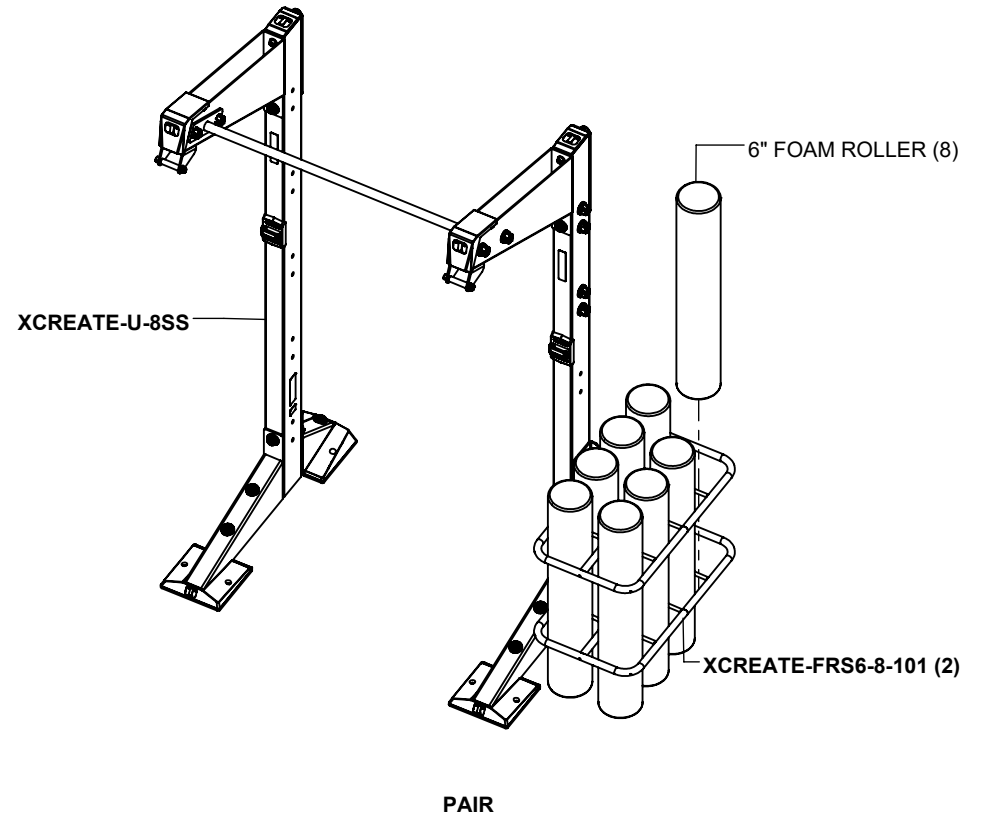
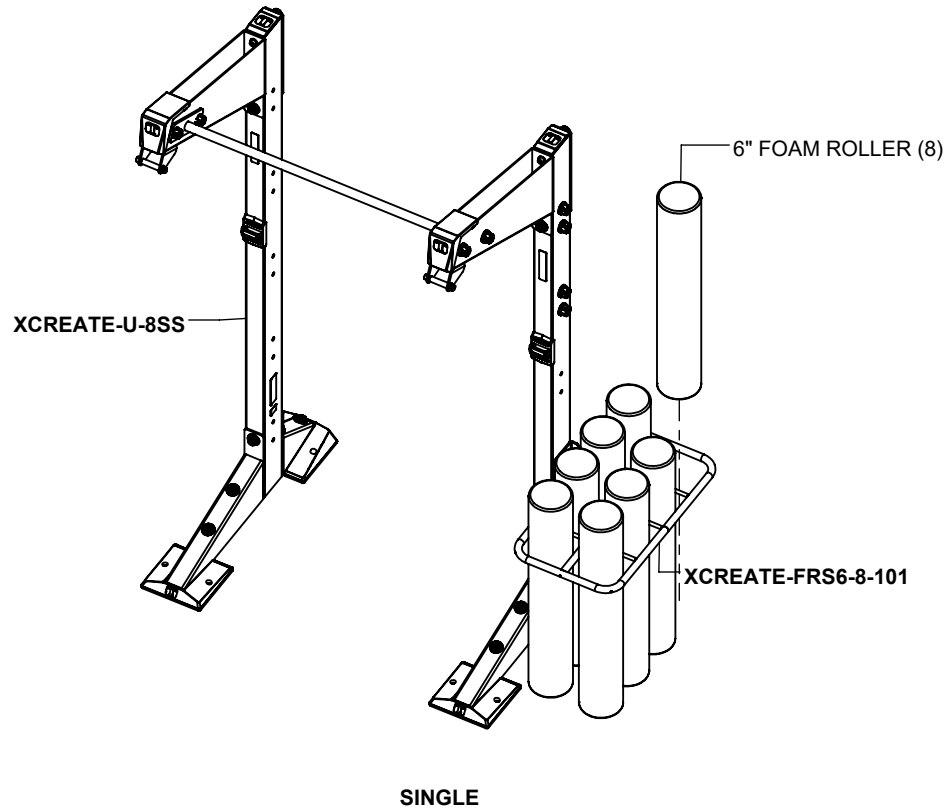

NOTES:

Assembly steps show a single and pair. For additional foam roller stability a pair is recommended.

LEVEL ATTACHMENT AND SECURELY tighten all bolt connections in this step.

The **XCREATE-U-7SS** is assembled the exact same way.

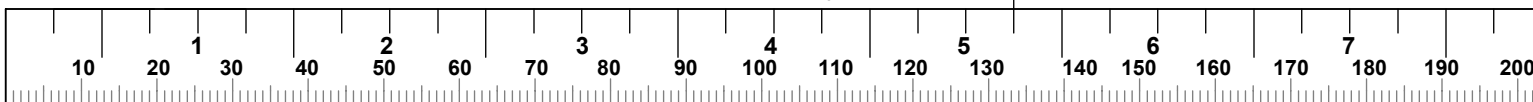

STALL BAR DIP ATTACHMENT

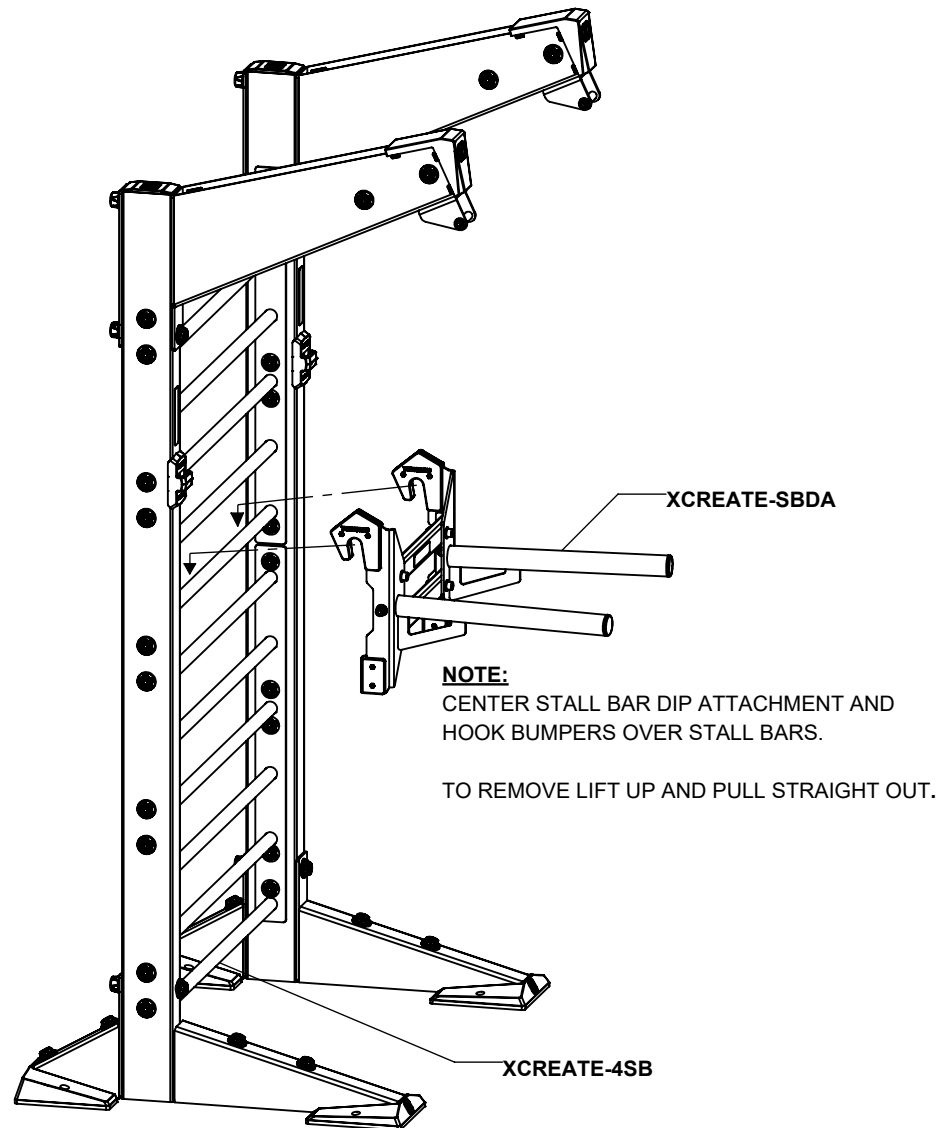

NOTES:

The XCREATE 4' stall bar module is required in this step. For module assembly see previous steps.

BCSA
BAR CATCH STORAGE ATTACHMENT

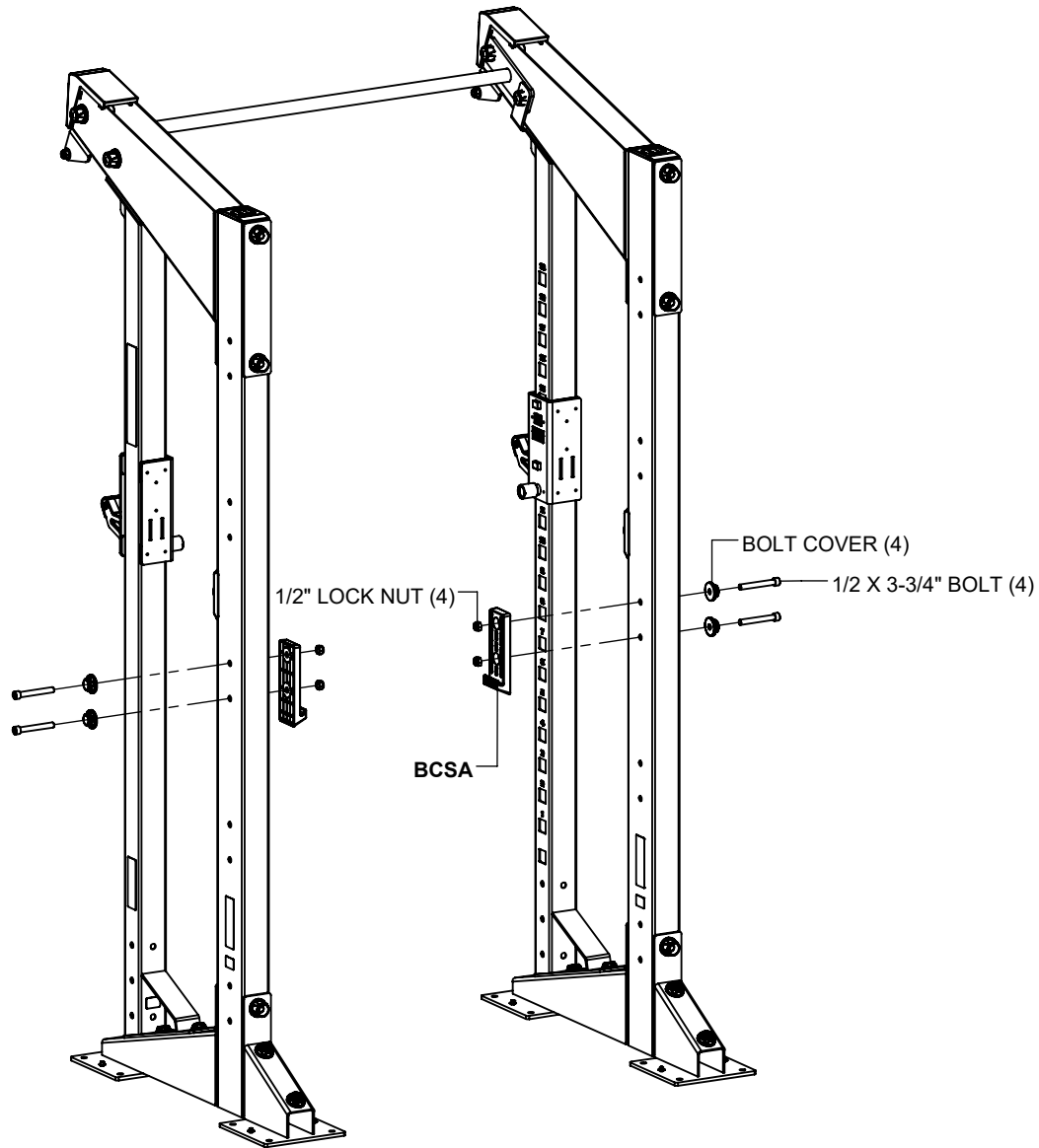

NOTES:

SECURELY tighten all bolt connections in this step.

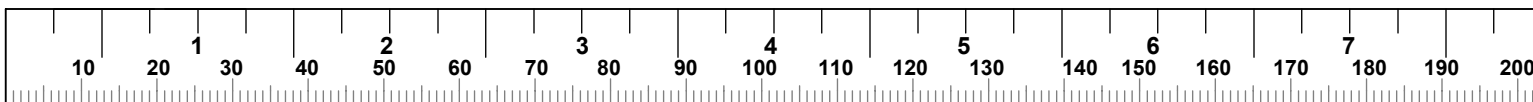

BCSA
BAR CATCH STORAGE ATTACHMENT

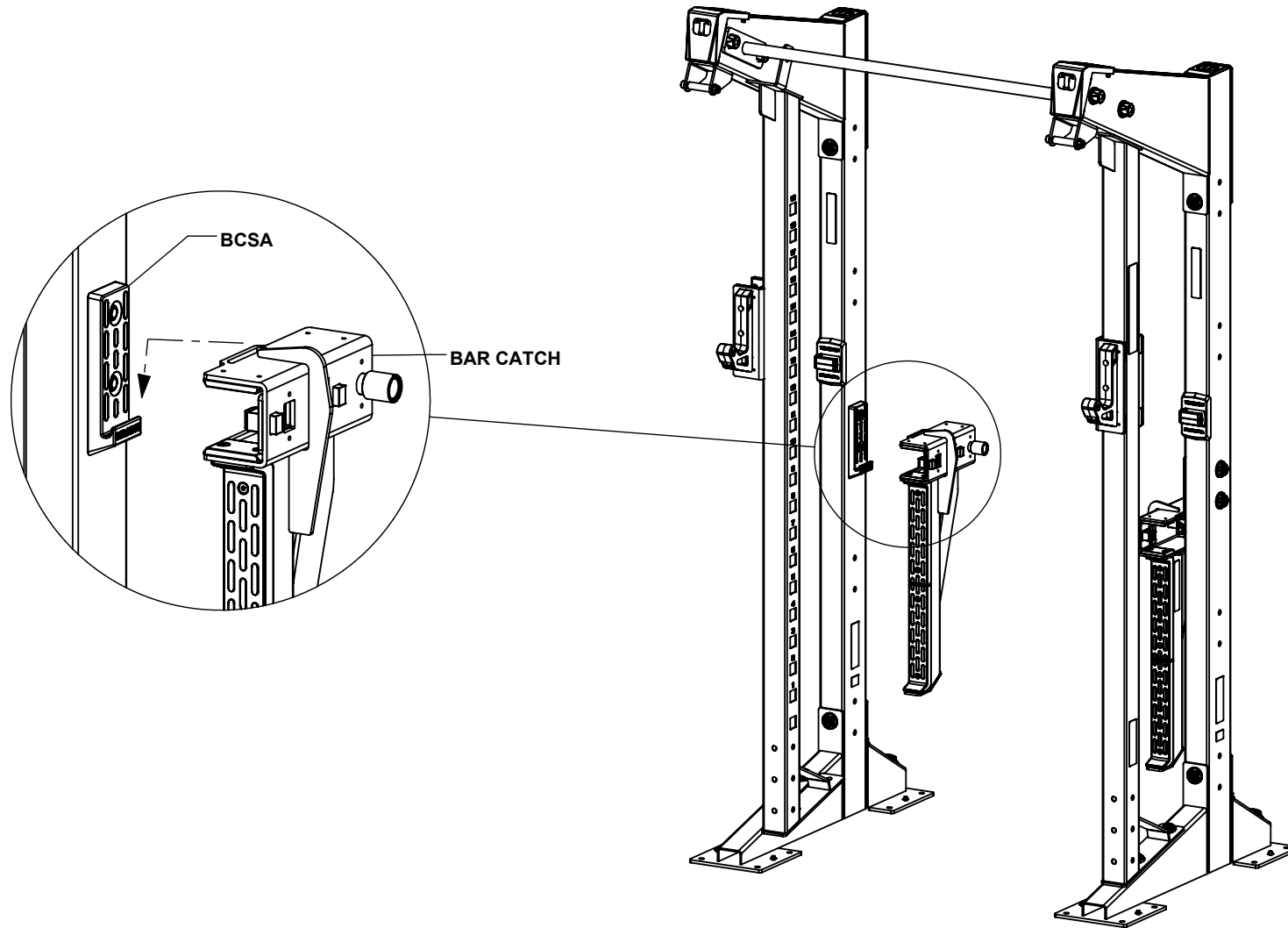

XCREATE-HMSC
MAGNETIC SUSPENSION CLIP

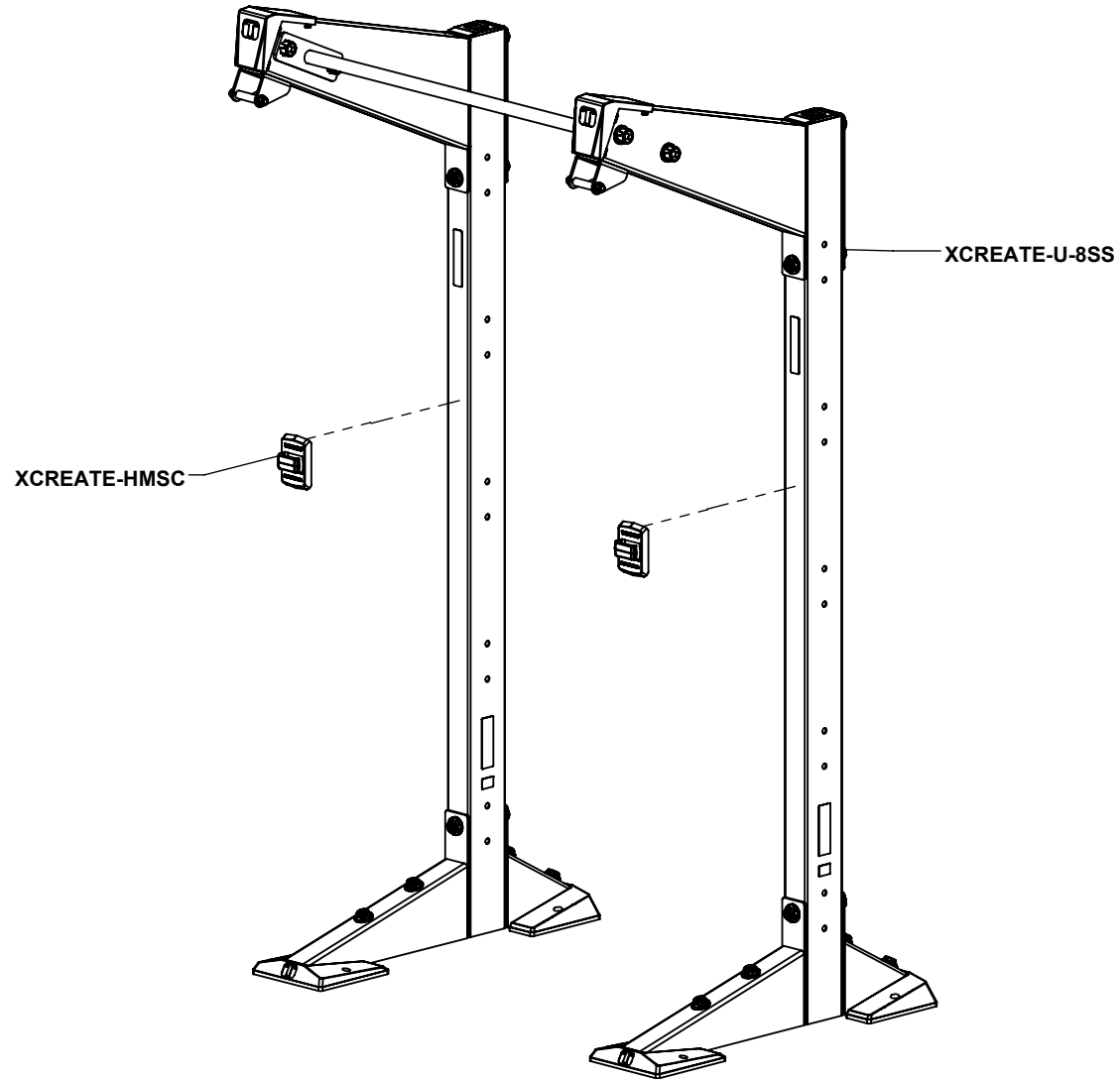

NOTES:

Suspension storage clip can be positioned to desired height.

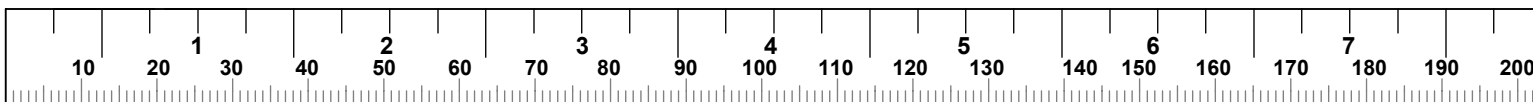

**CPWH
CHANGE PLATE WEIGHT HORN (QTY 2)**

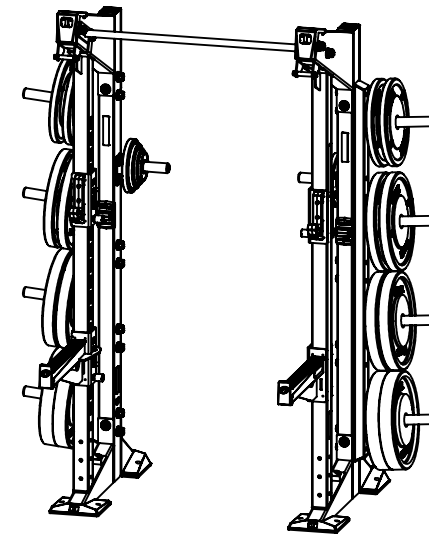
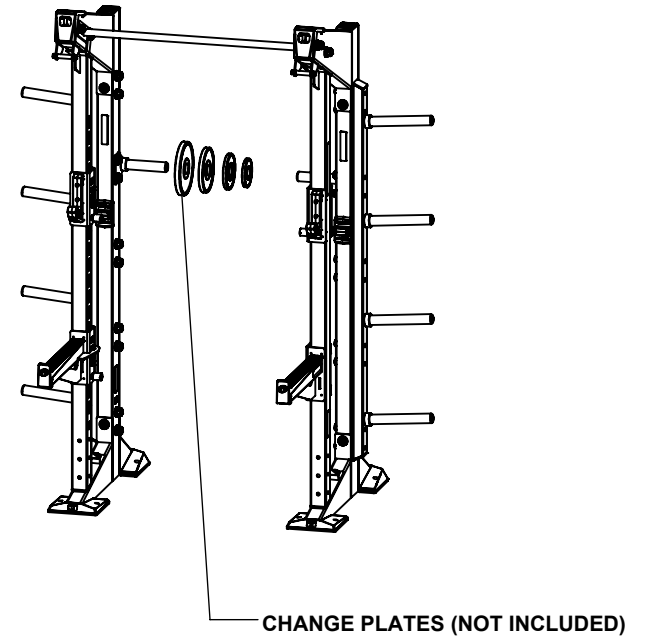
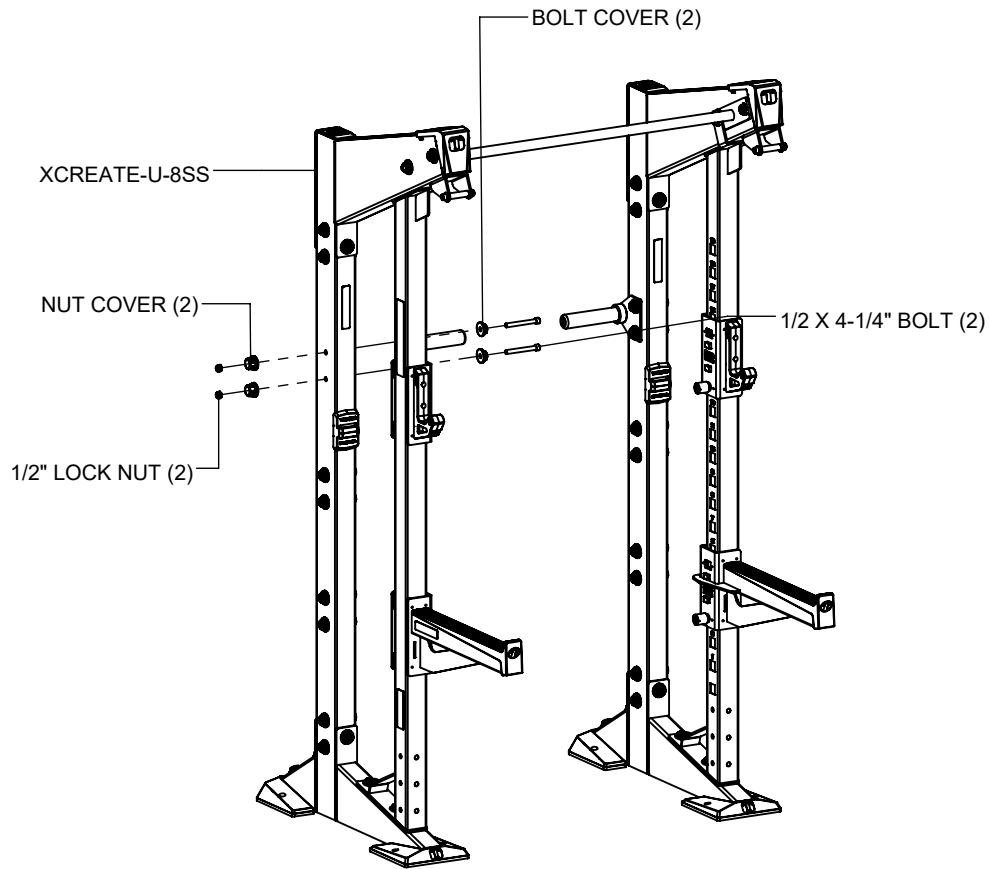

NOTES:

SECURELY tighten all bolt connections in this step.

(* **HARDWARE COVERS CAN** be used in place of washers in this step. **(SEE PAGE 3)**).

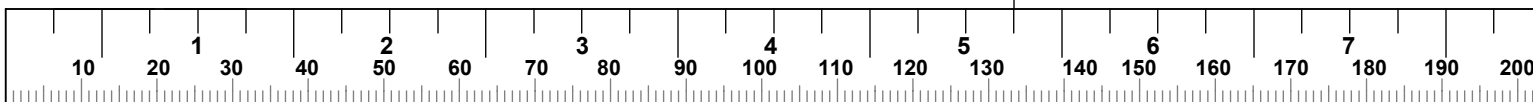

XCREATE-GRT / XCREATE-TP

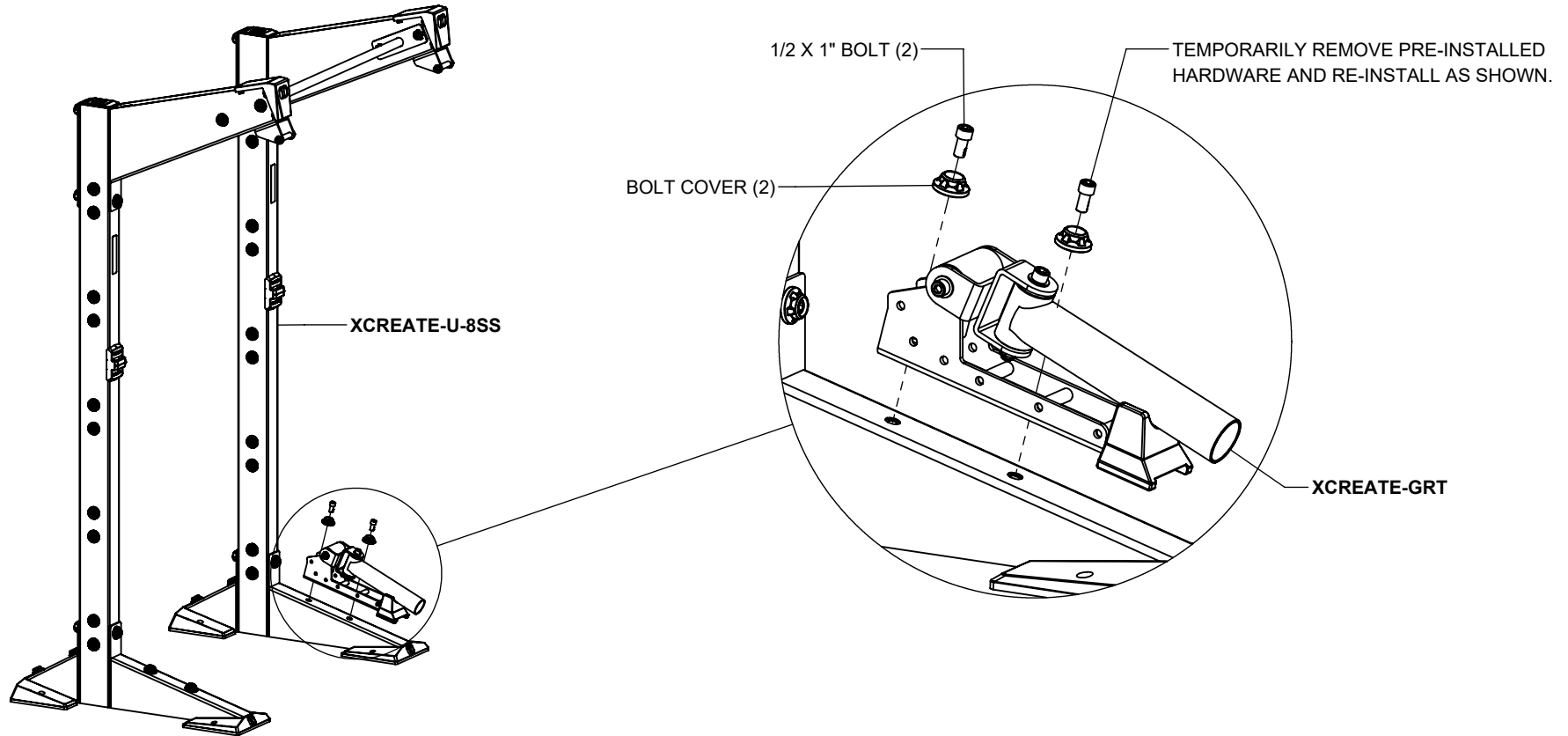

NOTES:

If more modules will be assembled, do not tighten bolts at this time.
If this is the only module being assembled, then **SECURELY** tighten all bolts in this step and previous steps.

The **XCREATE-U-7SS** is assembled the exact same way.

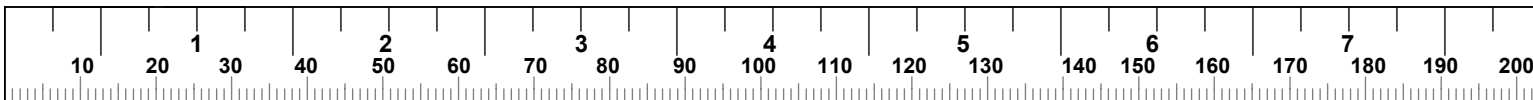

XCREATE-GRTPS / XCREATE-TP

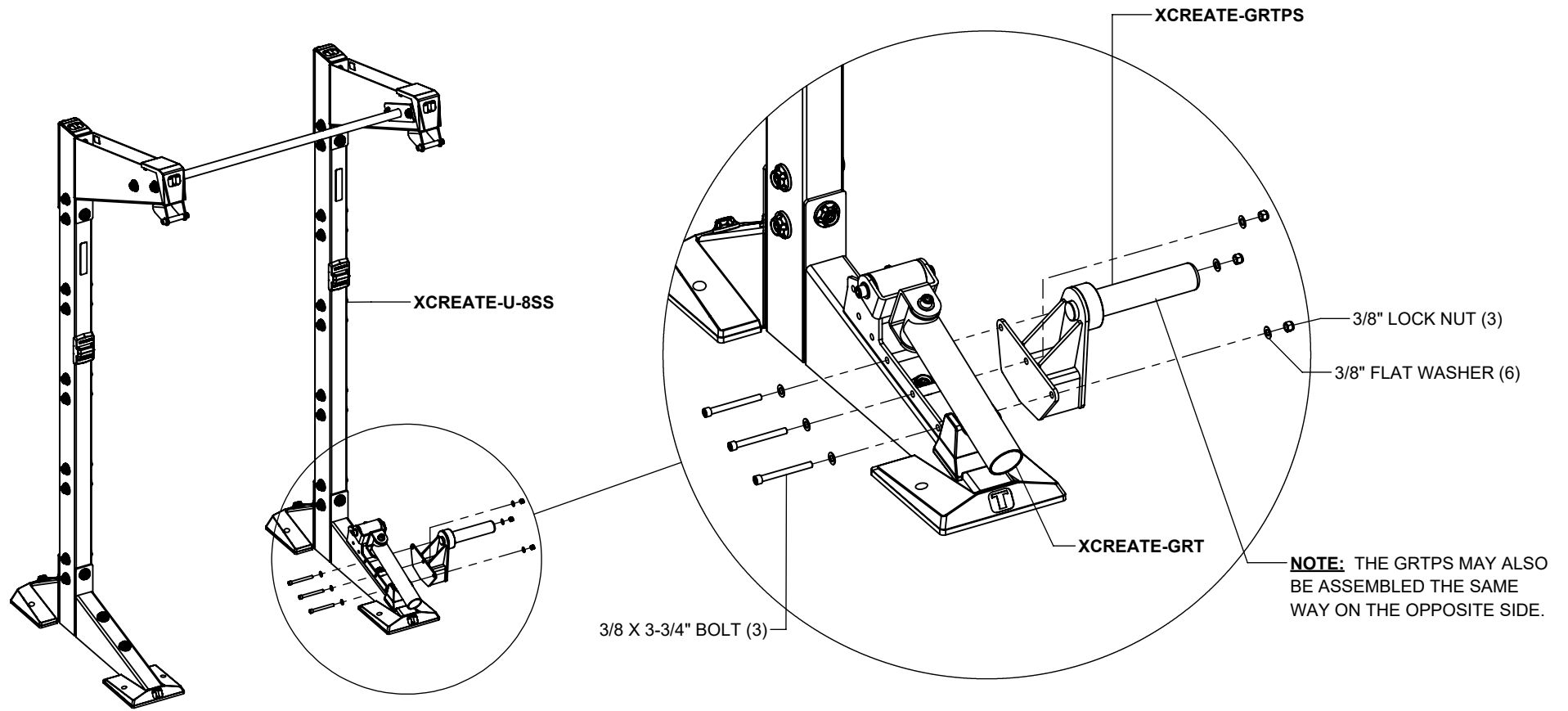

NOTES:

The XCREATE-U-7SS is assembled the exact same way.

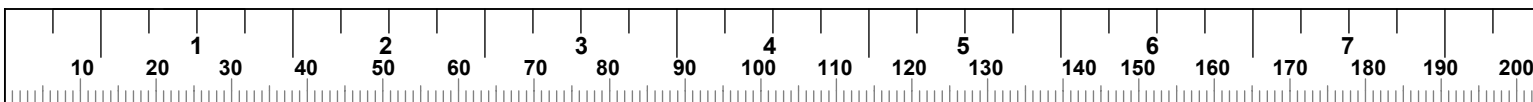

XCREATE-GRTBS / XCREATE-TP

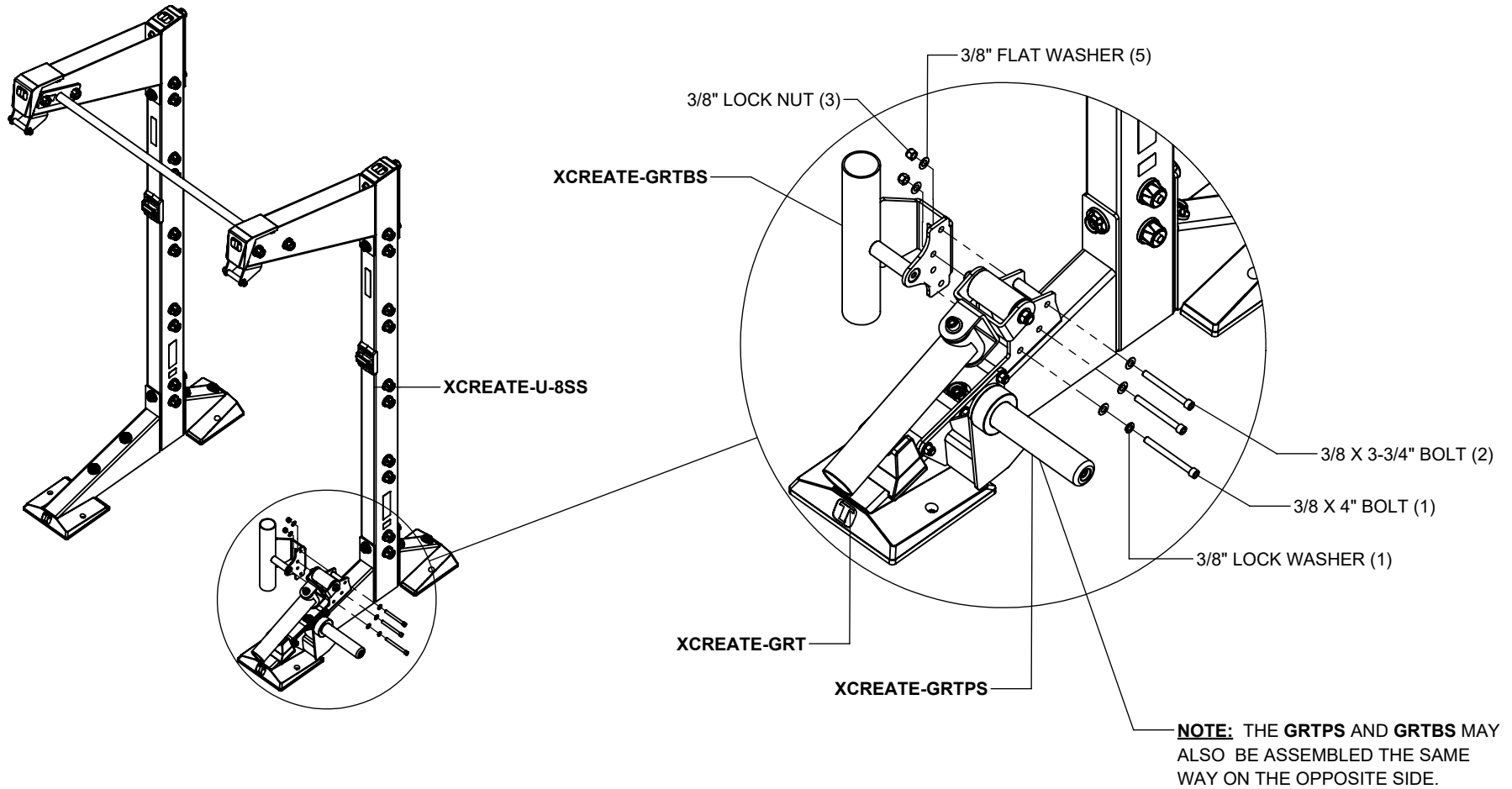

NOTES:

The XCREATE-U-7SS is assembled the exact same way.

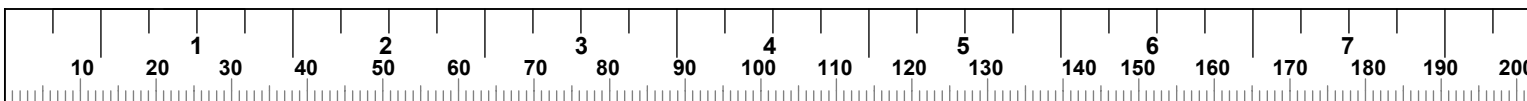

4' OFFSET STALL BAR

NOTE:

XCREATE-CC SHOWN, FOLLOW THE SAME STEPS FOR ASSEMBLING TO ANY CABLE MODULE.

NOTE:

LOOSEN CROSSMEMBER HARDWARE IF ALREADY ASSEMBLED. IF ASSEMBLING THE CABLE STATION AT THE SAME TIME, FOLLOW THESE STEPS BEFORE FULLY TIGHTENING HARDWARE.

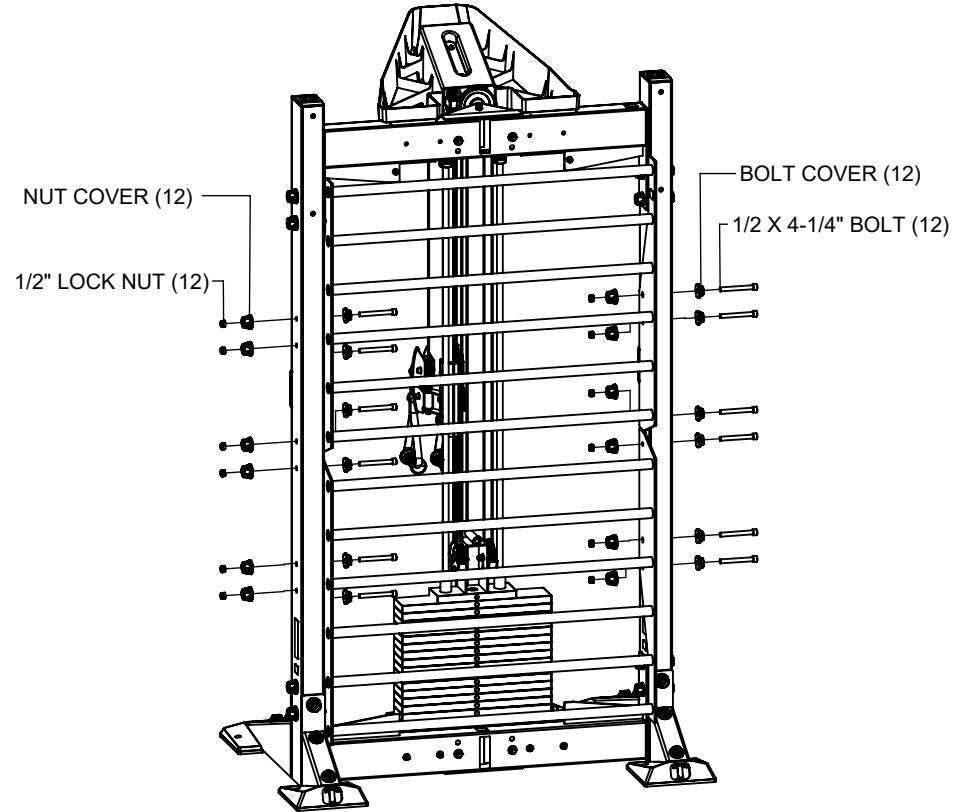
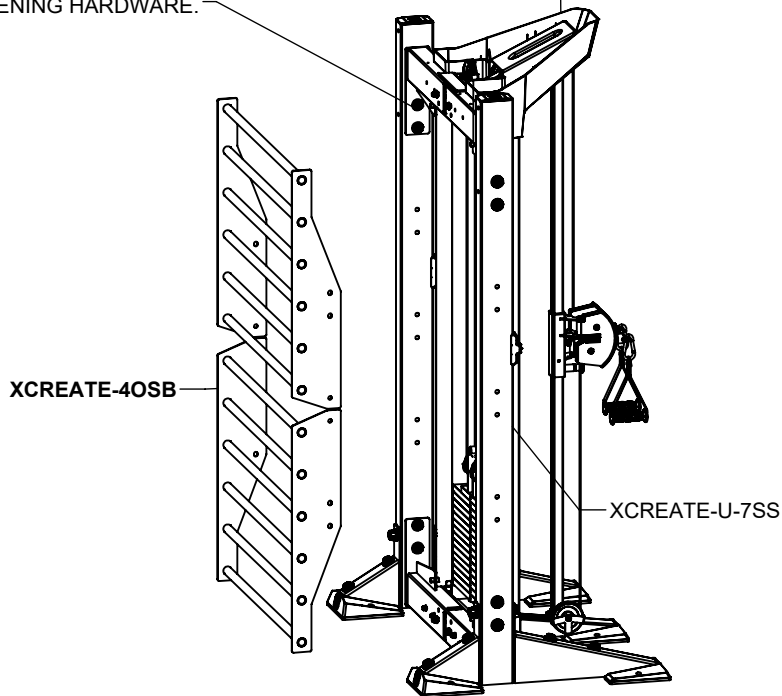

NOTES:

If more modules will be assembled, do not tighten bolts at this time. If this is the only module being assembled, then **SECURELY** tighten all bolts in this step and previous steps.

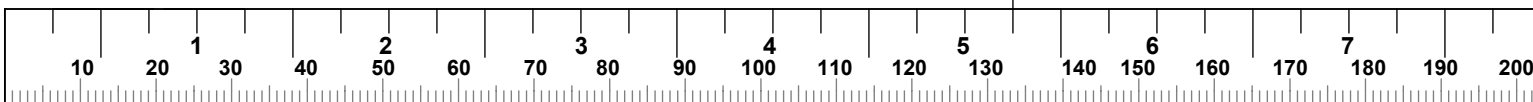

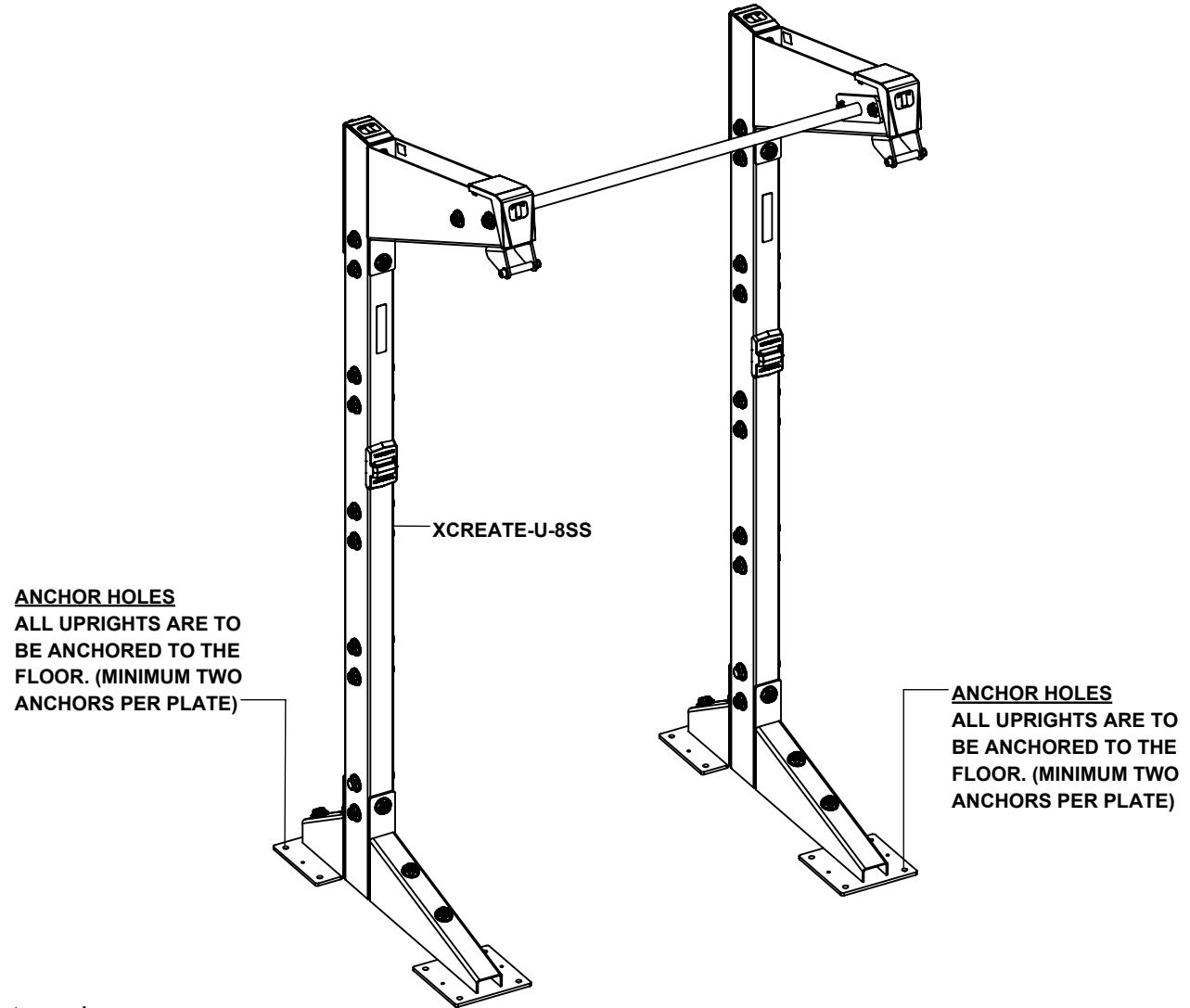

NOTES:

Make sure all bolts are **SECURELY** tightened.

Position system to desired location in the room.

Anchor system to the floor referencing X-CREATE ANCHORING INSTRUCTIONS which can be downloaded at www.torquefitness.com/assembly-manuals

WARNING!

ALL X-CREATE ARE REQUIRED TO BE ANCHORED TO THE FLOOR TO PREVENT ROCKING OR TIPPING DURING USE.

XCREATE-URETHANE BOOTS

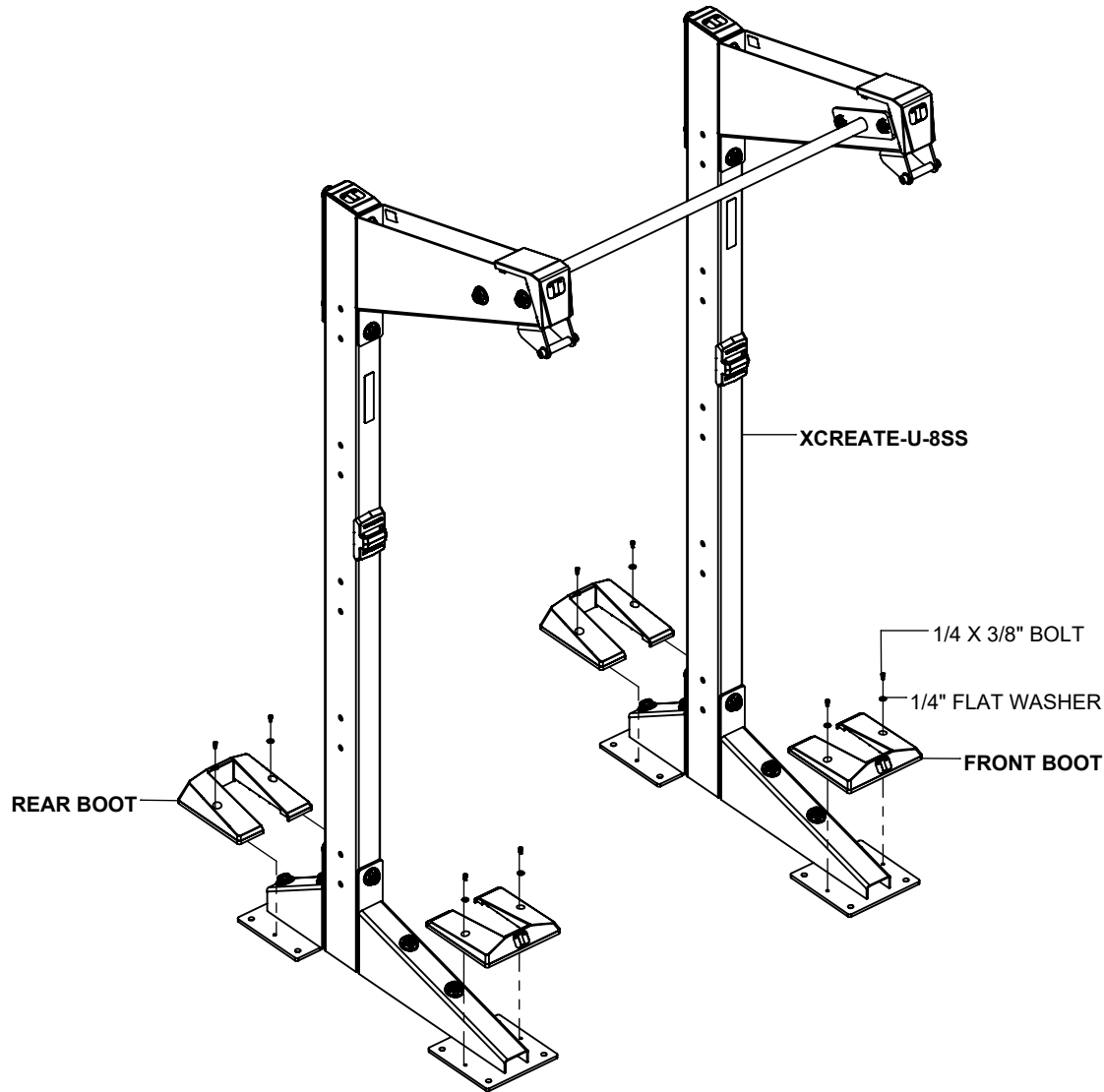

REAR BOOT

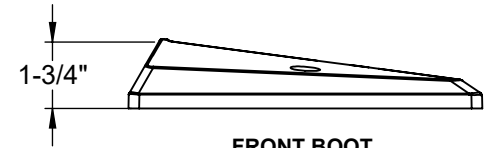

FRONT BOOT

NOTES:

The URETHANE BOOTS and hardware are packaged with the upright boxes

SECURELY tighten bolt connections in this step.

The **XCREATE-U-7SS** is assembled the exact same way.

Repeat this step for every upright.

