

# XCREATE CENTER SPACE ASSEMBLY GUIDE

VERSION: XCCS

PART #: 5844001-F

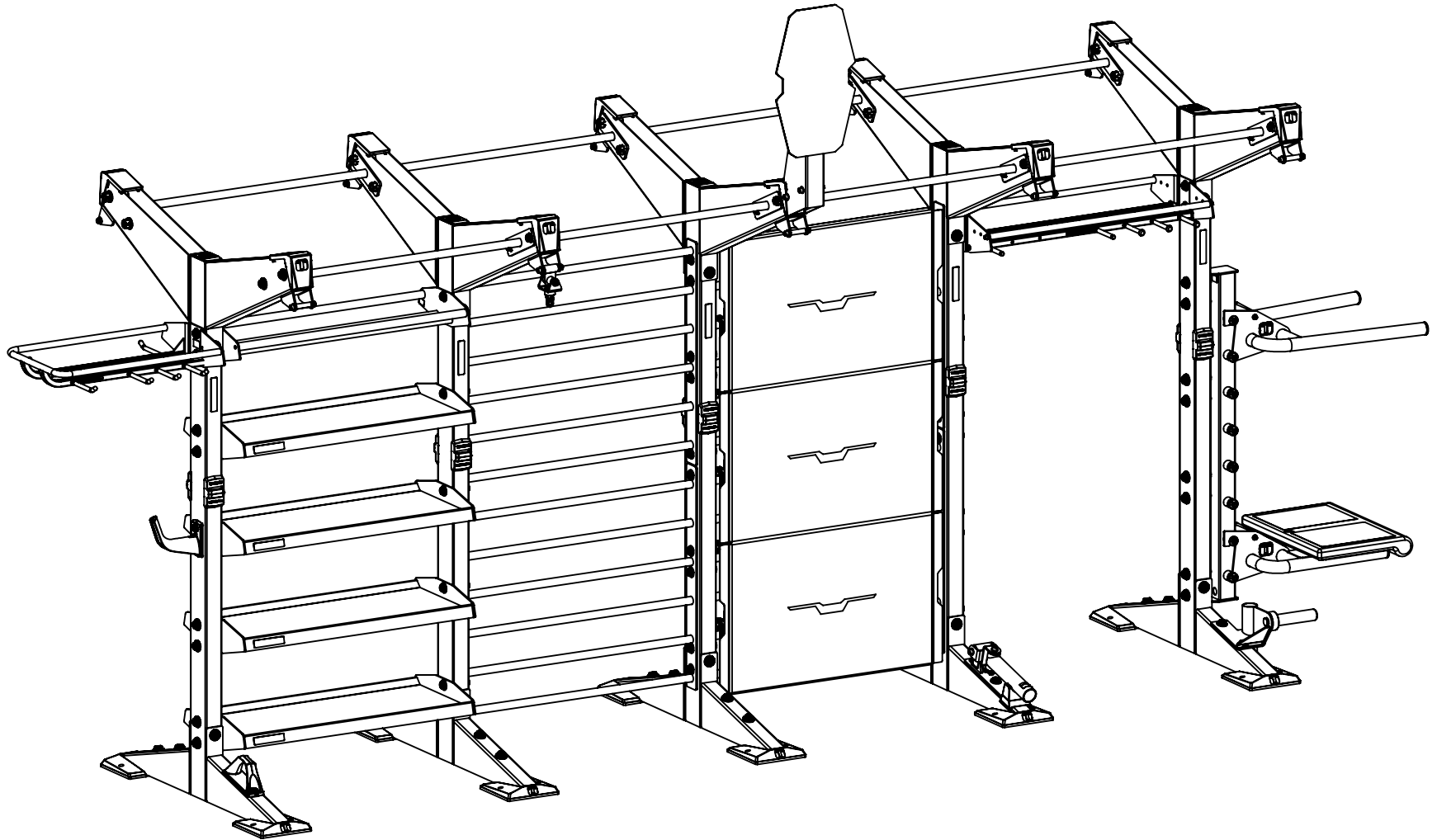

**TORQUE** USA

## TABLE OF CONTENTS

1. OVERVIEW AND TOOLS REQUIRED: **PAGE 3**
2. UPRIGHT ASSEMBLY: **PAGE 4**
3. HARDWARE COVERS: **PAGE 5**
4. ONE MODULE ASSEMBLY: **PAGE 6**
5. CABLE MODULES AND SMITH MODULE: **PAGE 10**
6. MODULE ASSEMBLY
  - 8' UPRIGHT MODULE EXTENSION: **PAGES 11-12**
  - 4'/6' ACCESSORY STORAGE MODULE: **PAGES 13-14**
  - 4'/6' UNIVERSAL BALL & HANGING STORAGE MODULE: **PAGES 15-16**
  - 4' STALL BAR MODULE: **PAGES 17-18**
  - 4' BALL TARGET PAD MODULE: **PAGES 19-22**
  - 8' OLYMPIC LIFTING STATION MODULE: **PAGES 23-27**
  - 4'/6' ACCESSORY & BUMPER BOOKSHELF STORAGE MODULE: **PAGES 28-29**
  - 4' TANK DOCKING MODULE: **PAGES 30-33**
  - 4' X 5 BARBELL STORAGE MODULE: **PAGES 34-37**
  - 4' X 10 BARBELL STORAGE MODULE: **PAGES 38-41**
  - 4' 2 SIDED X 10 BARBELL STORAGE MODULE: **PAGES 42-45**
  - 4' 2 SIDED X 20 BARBELL STORAGE MODULE: **PAGES 46-49**
  - 4' MONITOR MOUNT & STORAGE MODULE: **PAGES 50-53**
  - 4' CUSTOM SIGN AND HANGING STORAGE MODULE: **PAGES 54-55**
  - 2.5' BALL AND HANGING STORAGE MODULE: **PAGES 56-57**
  - 6' RECTANGULAR CROSS MODULE: **PAGES 58-59**
  - 4' HEAVY BAG MODULE: **PAGES 60-61**
  - ACCESSORY PEGS & MAT STORAGE PINS: **PAGE 62**
  - ACCESSORY TRAY LABELS: **PAGES 63**
7. ATTACHMENT ASSEMBLY
  - BALL & HANGING STORAGE EXTENSION: **PAGE 68**
  - BATTLE ROPE ANCHOR: **PAGE 69**
  - HANGING STORAGE HOOK: **PAGE 70**
  - DOUBLE PLAY: **PAGE 71**
  - HORIZONTAL MOUNT GROUND ROTATIONAL TRAINER: **PAGE 72**
  - 3-DIMENSIONAL SWIVEL: **PAGES 73-74**
  - BALL TARGET: **PAGES 75-77**
  - RESISTANCE BAND ANCHOR: **PAGE 78**
  - VERTICAL DUMBBELL RACKS: **PAGE 79**
  - 4' MULTI GRIP CROSS: **PAGE 80**
  - 4' SINGLE SIDE HORIZONTAL WEIGHT STORAGE: **PAGE 81**
  - TOP BOOM EXTENSION: **PAGES 82-85**
  - ATTACHMENT ANCHOR: **PAGE 86**
  - DIP ATTACHMENT: **PAGE 87**
  - PLYO STEP: **PAGE 88**
7. ATTACHMENT ASSEMBLY CONTINUED
  - ATTACHMENT EXTENSION: **PAGES 89-90**
  - ATTACHMENT EXTENSION & 3 DIMENSIONAL SWIVEL W/MOUNT: **PAGE 91**
  - RELENTLESS ROPE TRAINER (UPRIGHT): **PAGES 92-93**
  - BOOM MOUNT: **PAGES 94-95**
  - BOOM MOUNT (RELENTLESS ROPE & RIPPER): **PAGE 96-97**
  - SIDE ATTACHMENT MOUNT: **PAGE: 98**
  - XCREATE-6RX (RELENTLESS ROPE & RIPPER): **PAGE 99**
  - XCREATE-6RX (BRIDGE BALL TARGET & ROCK CLIMBING KIT): **PAGE 100**
  - BOSU STORAGE ATTACHMENT: **PAGE 101**
  - FOAM ROLLER STORAGE: **PAGES 102-103**
  - STALL BAR DIP ATTACHMENT: **PAGE 104**
  - BAR CATCH STORAGE ATTACHMENT: **PAGE 105-106**
  - SUSPENSION CLIP: **PAGE 107**
  - CHANGE PLATE WEIGHT HORN: **PAGE 108**
  - XCREATE-GRT / XCREATE-TP: **PAGE 109**
  - XCREATE-GRTPS / XCREATE-TP: **PAGE 110**
  - XCREATE-GRTBS / XCREATE-TP: **PAGE 111**
  - 4' OFFSET STALL BAR: **PAGE 112**
  - DOUBLE SIDED UNIVERSAL HEAVY BAG ATTACHMENT: **PAGES 113-115**
8. ANCHORING: **PAGE 116**
9. URETHANE BOOTS: **PAGE 117**

## **WARNING!**

**ALL X-CREATE ARE REQUIRED TO BE ANCHORED TO THE FLOOR TO PREVENT ROCKING OR TIPPING DURING USE.**

## OVERVIEW AND TOOLS REQUIRED

X-CREATE Center Space Systems can be customized in countless ways. This manual provides instructions for assembling base units, module options and attachment options.

Not all modules or attachments are detailed in this assembly guide. For further instruction on these, reference the individual guide for the module being installed.

If you worked with Torque X-Team Design during the purchasing process, please request a Bill of Material Drawing to reference your exact set-up. For assistance, contact [www.sales@torquefitness.com](mailto:www.sales@torquefitness.com) or call (763) 754-7533

### **NOTE:**

When assembling any X-CREATE System that is longer than one module wide, the hardware will be shared between two side by side modules and pull-up bars. It is recommended to keep all bolt connections loose until the base system and all of the module stations have been assembled. Securely tighten all frame connections at this time, and then proceed to the attachment options. Attachment options can be securely tightened as they are assembled.

### **TOOLS FOR ASSEMBLY:**

- 3/8" ALLEN WRENCH
- 5/16" ALLEN WRENCH
- 3/16" ALLEN WRENCH
- 3/4" WRENCH OR SOCKET
- 9/16" WRENCH OR SOCKET
- 1/2" WRENCH OR SOCKET
- RUBBER Mallet

## **WARNING!**

**ALL X-CREATE ARE REQUIRED TO BE ANCHORED TO THE FLOOR TO PREVENT ROCKING OR TIPPING DURING USE.**

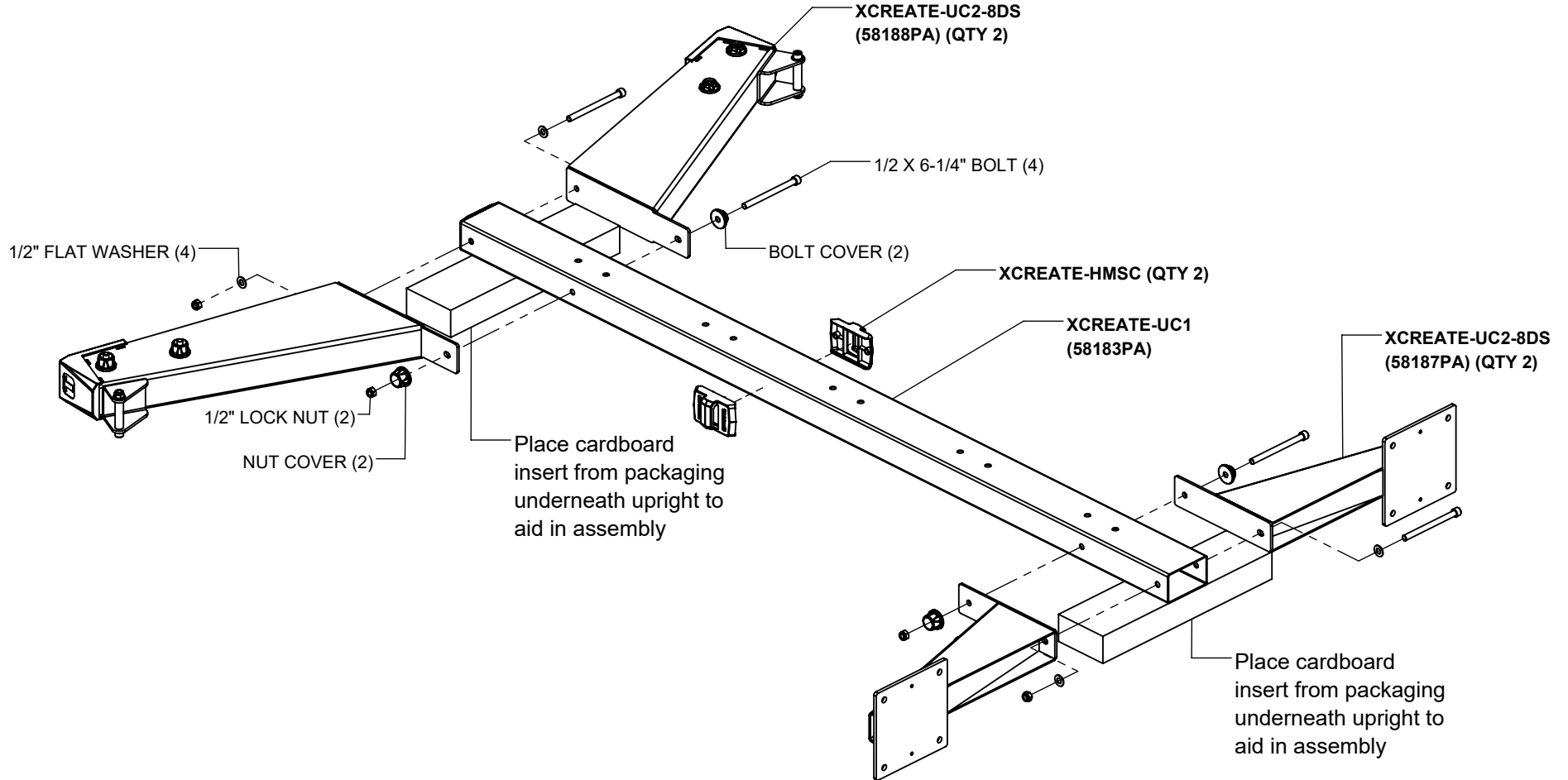

**NOTES:**

This step requires two people to assemble. Please get help.

Assemble the UPRIGHT on the floor.

Assemble all parts together first, then **SECURELY** tighten all bolt connections.

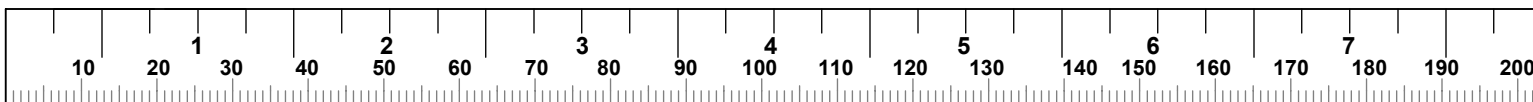

## HARDWARE COVERS

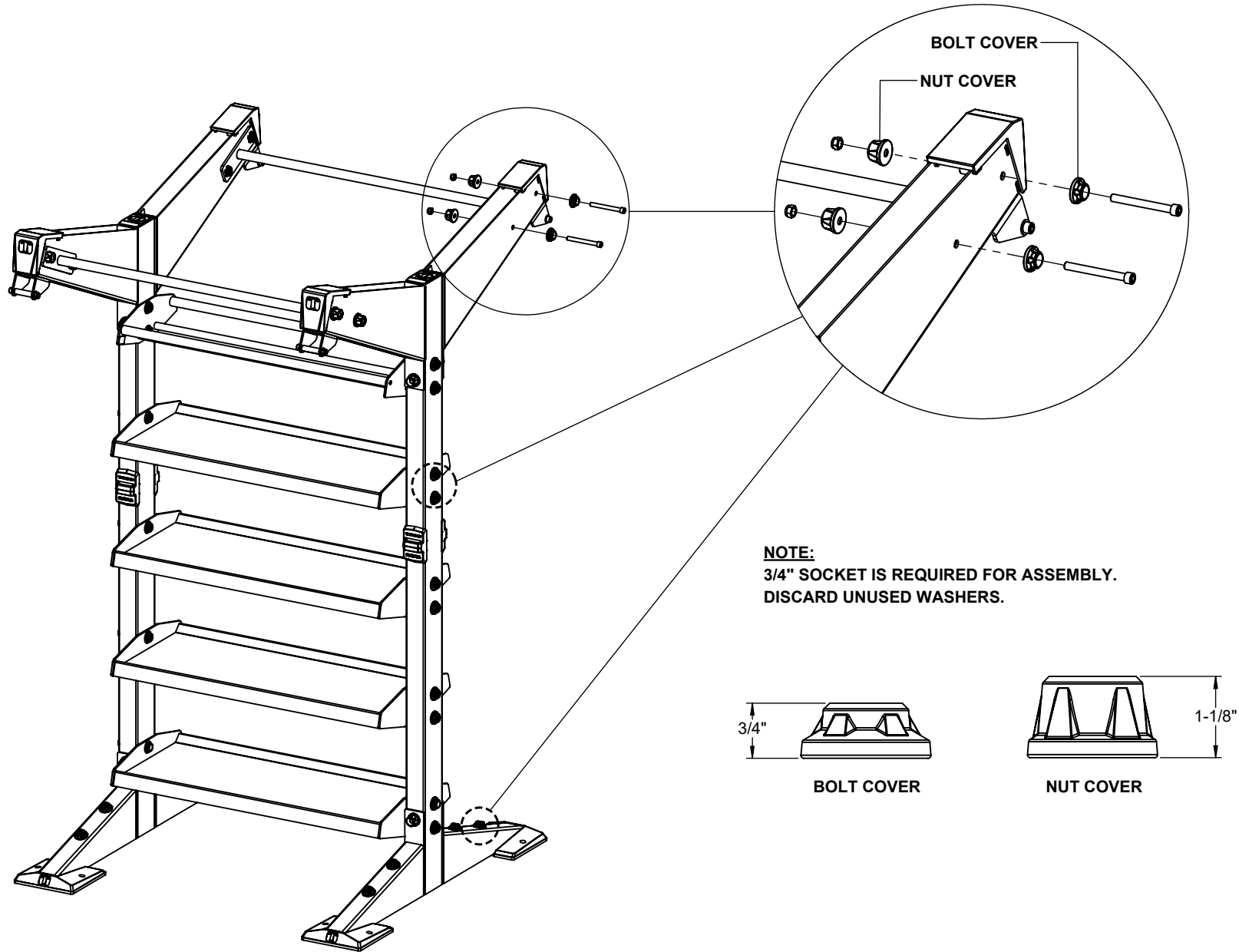

### **IMPORTANT NOTICE ABOUT HARDWARE COVERS:**

The bolt and nut covers **may not fit all assembly applications.** Use the flat washers included when shown in this guide.

# ONE MODULE ASSEMBLY

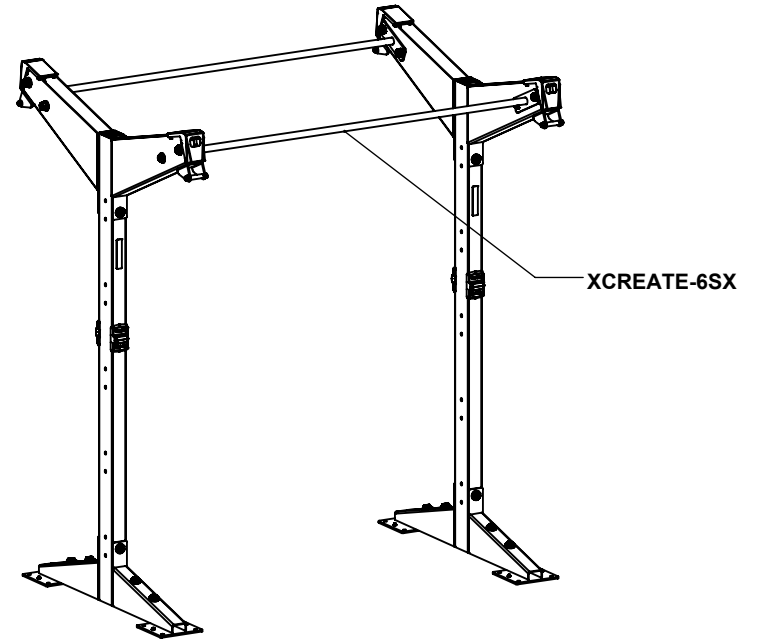
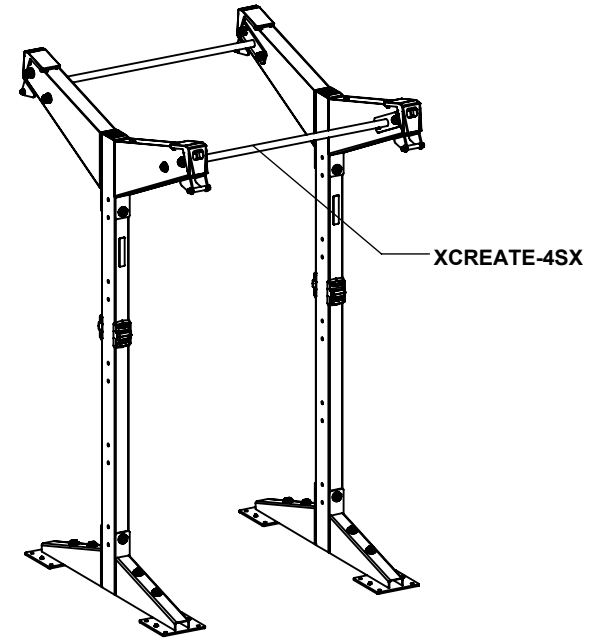
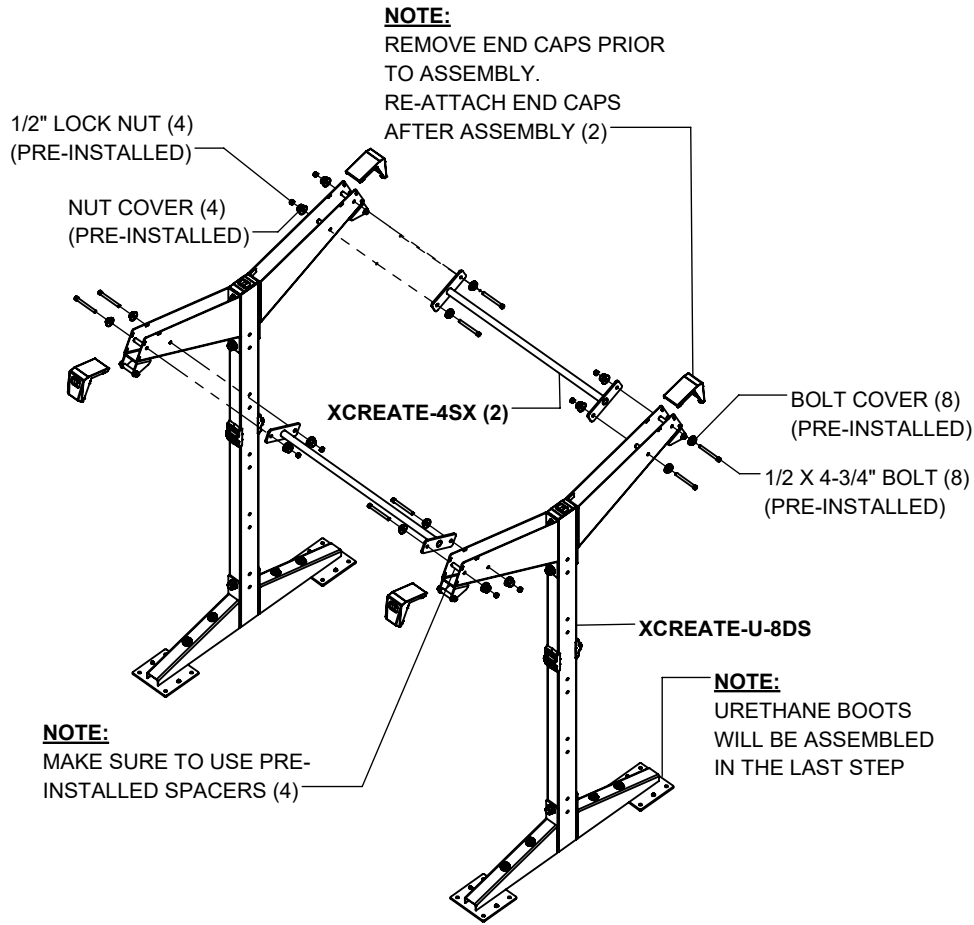

## NOTES:

For the purpose of illustration the XCREATE-4SX is shown. The XCREATE-6SX is assembled the same way.

**LOOSELY** assemble bolt connections in this step.

If more than one module will be assemble, refer to **PAGE 10**.

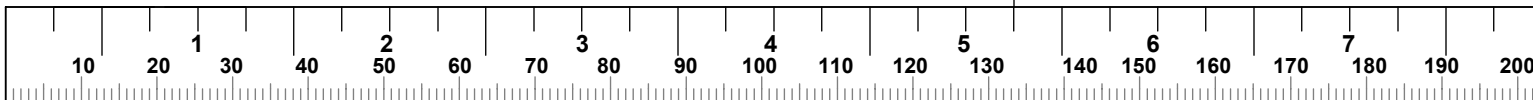

**MODULES**

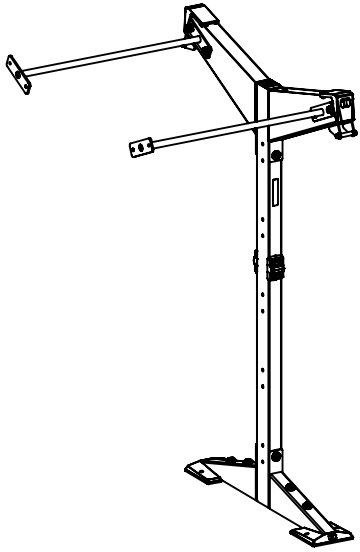

**8' UPRIGHT  
MODULE EXTENSION**

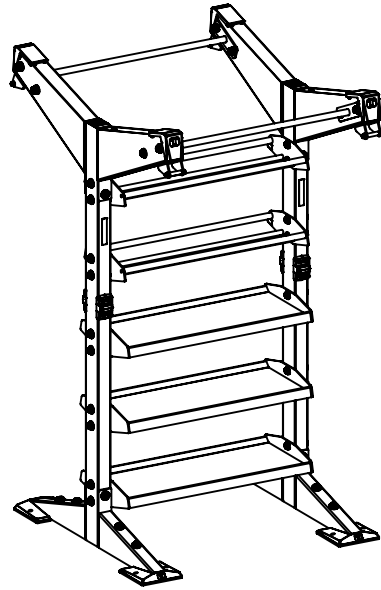

**4' / 6' STORAGE MODULE**

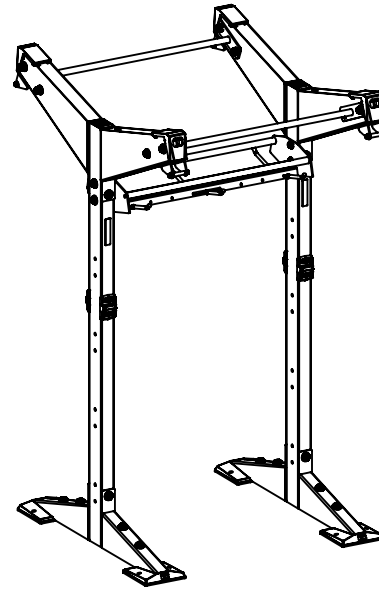

**4' / 6' BALL & HANGING  
STORAGE MODULE**

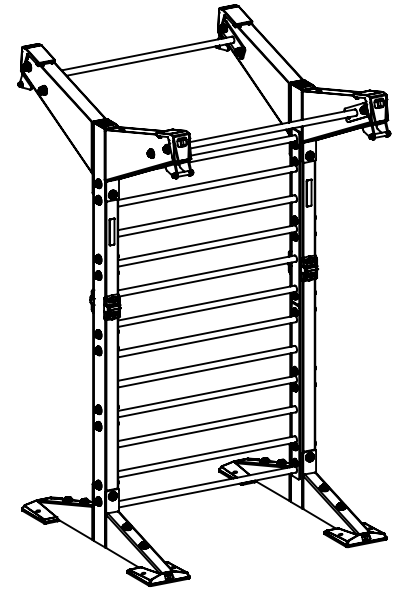

**4' STALL BAR MODULE**

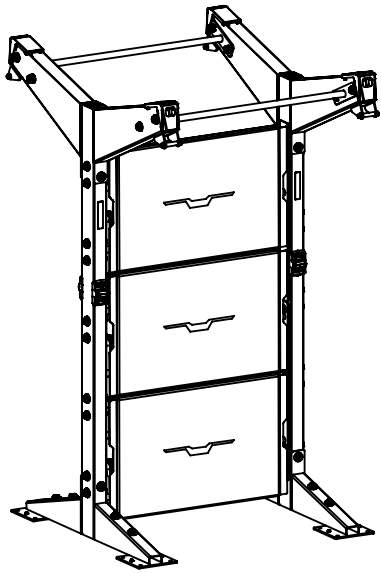

**4' BALL TARGET WALL PAD  
MODULE**

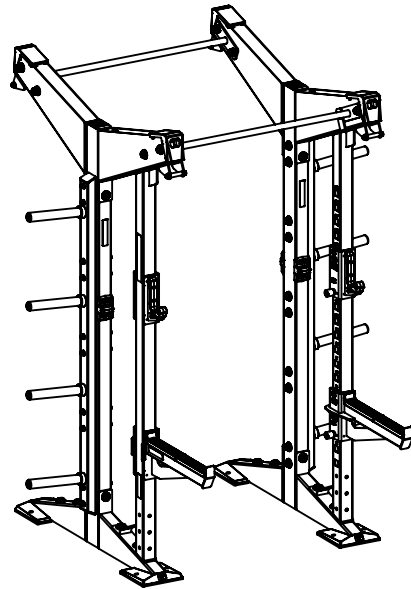

**8' OLYMPIC LIFTING  
STATION MODULE**

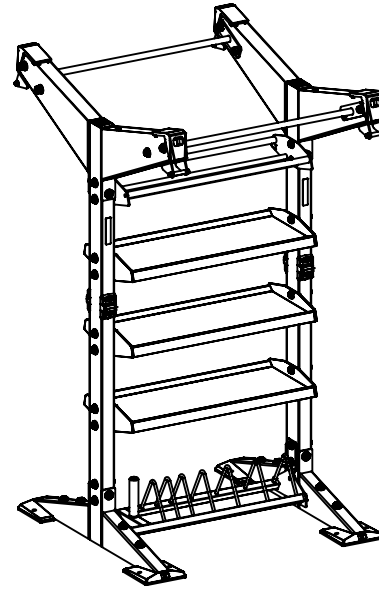

**4' / 6' ACCESSORY & BUMPER  
STORAGE MODULE**

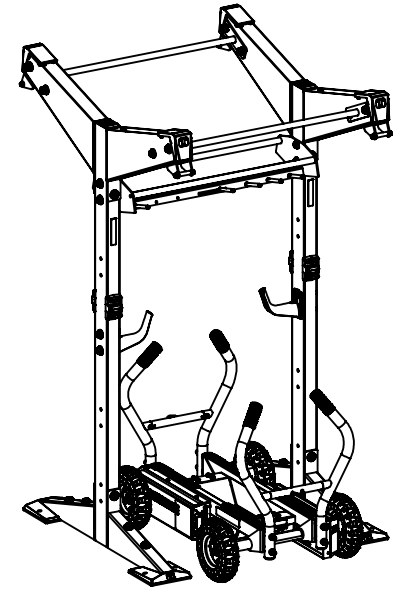

**4' TANK DOCKING MODULE**

**MODULES**

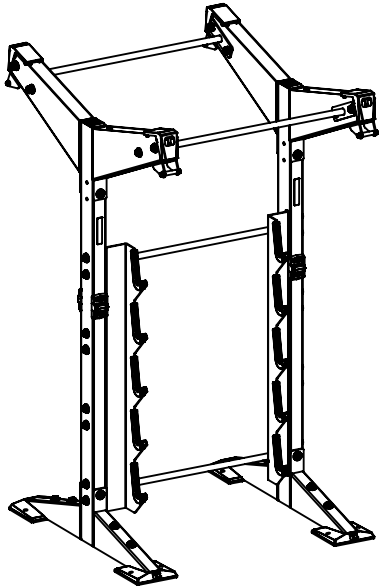

**4' X 5 BARBELL STORAGE  
MODULE**

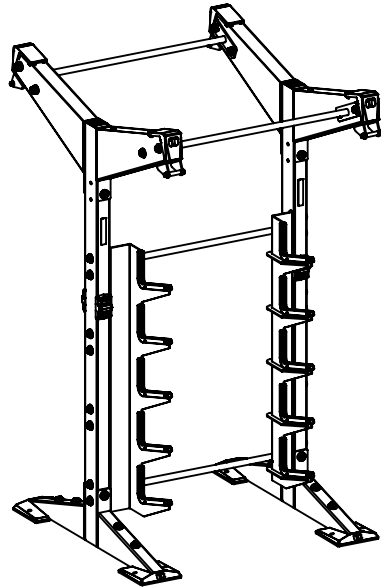

**4' X 2 SIDED X 10 BARBELL  
STORAGE MODULE**

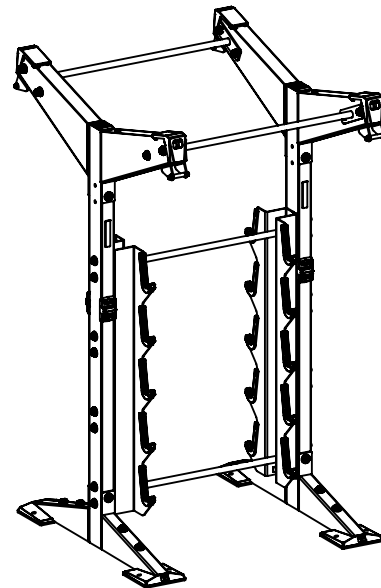

**4' X 10 BARBELL STORAGE  
MODULE**

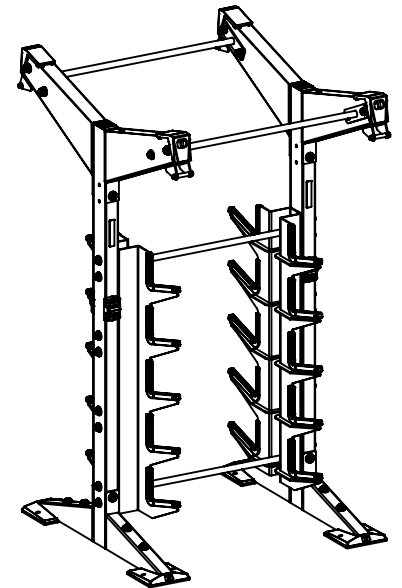

**4' X 2 SIDED X 20 BARBELL  
STORAGE MODULE**

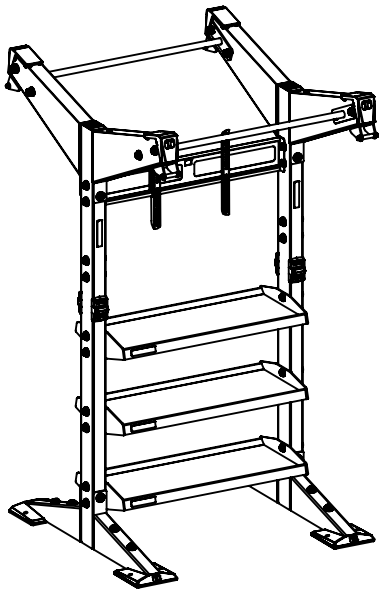

**4' MONITOR MOUNT  
STORAGE MODULE**

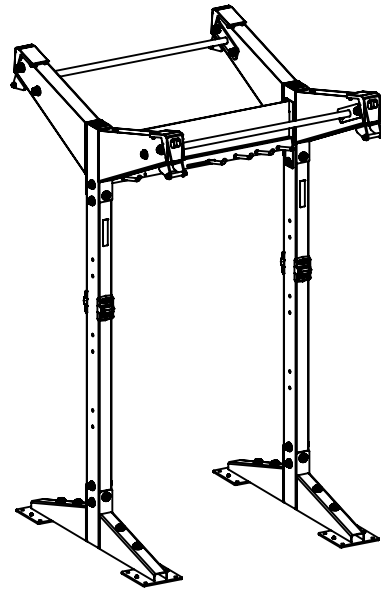

**4' CUSTOM SIGN AND  
HANGING STORAGE MODULE**

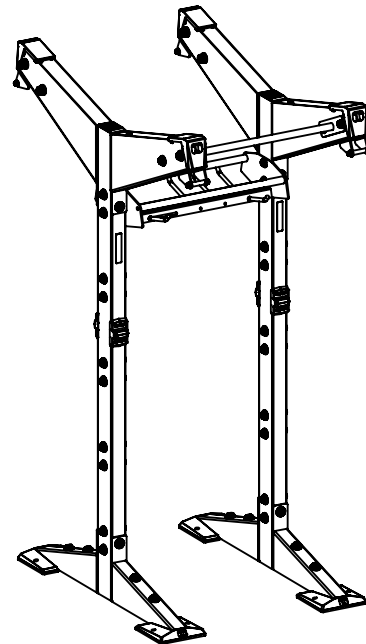

**2.5' BALL AND HANGING STORAGE  
MODULE**

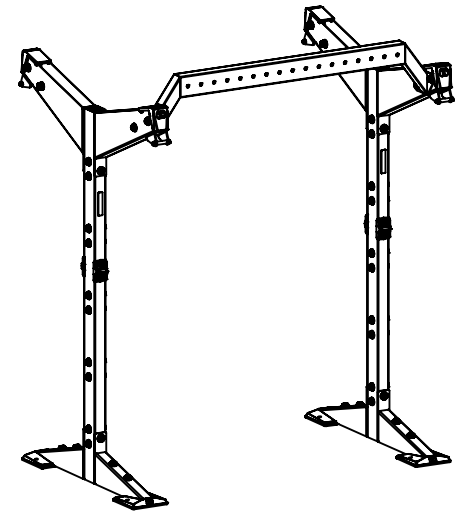

**6' RECTANGULAR  
CROSS MODULE**

**MODULES**

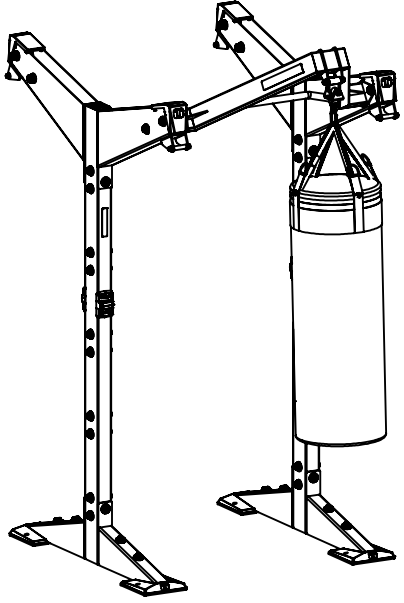

**4' HEAVY BAG MODULE**

**NOT COVERED IN THIS GUIDE**

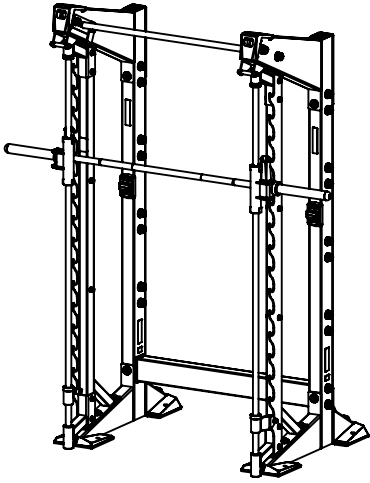

**SMITH MODULE**

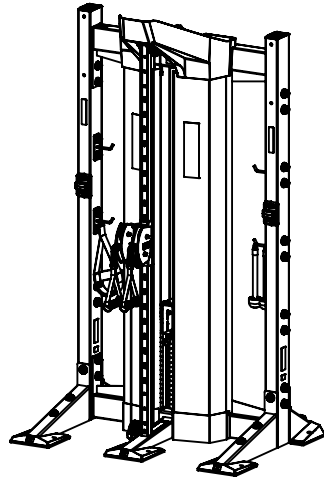

**CABLE COMPONENT  
MODULE**

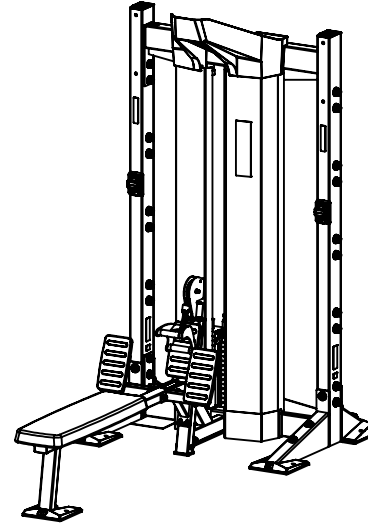

**SEATED ROW  
MODULE**

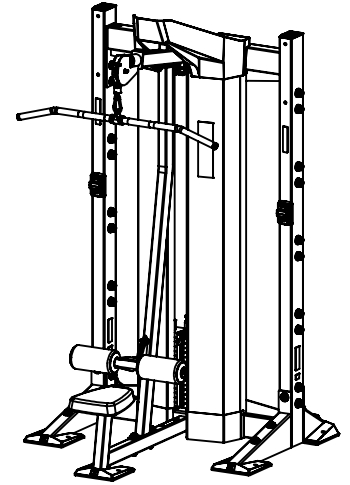

**LAT PULL DOWN  
MODULE**

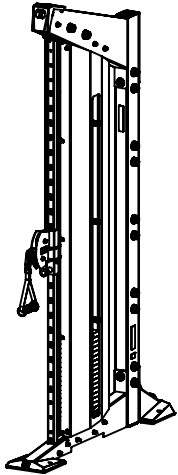

**UPRIGHT CABLE COLUMN**

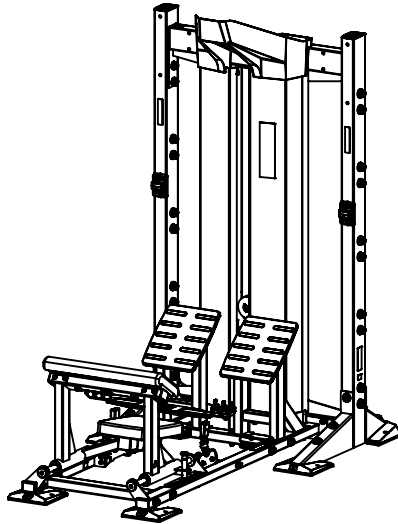

**HIP THRUST MODULE**

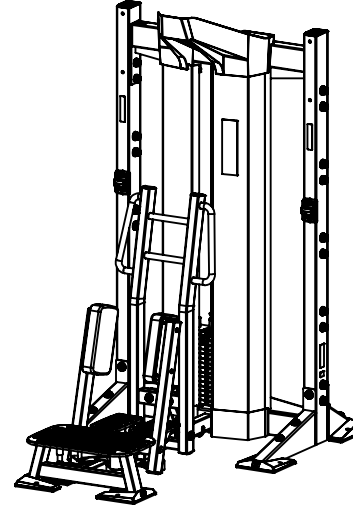

**STANDING ABDUCTOR  
MODULE**

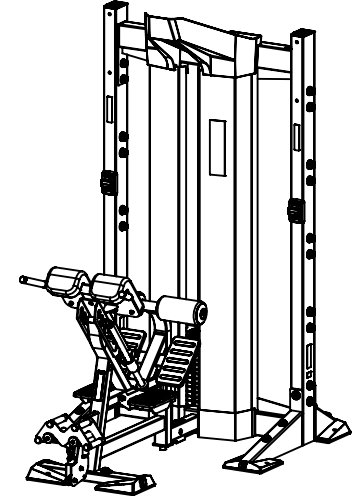

**BACK EXTENSION  
MODULE**

**NOTES:**

For the above modules and attachments, visit [Torquefitness.com](https://commercial.torquefitness.com) for the specific assembly manual for the product being assembled. The manuals can be downloaded at <https://commercial.torquefitness.com/pages/assembly-manuals>

**8' UPRIGHT MODULE EXTENSION**

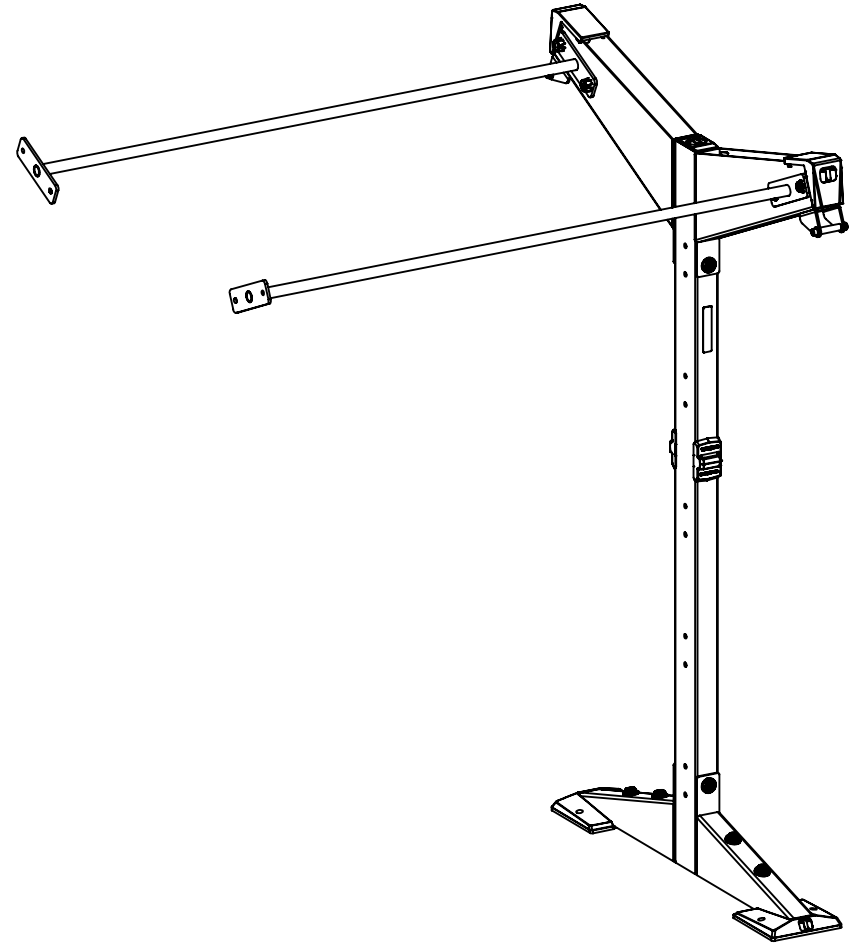
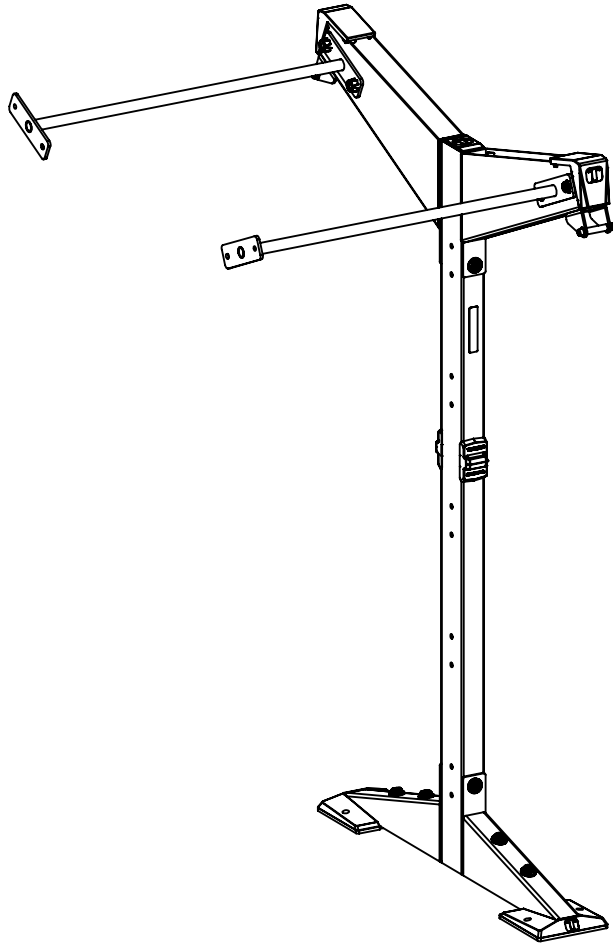

## 8' UPRIGHT MODULE EXTENSION

**NOTE:**

MAKE SURE TO USE PRE-INSTALLED SPACERS (4)

**NOTE:**

REMOVE END CAP PRIOR TO ASSEMBLY.  
RE-ATTACH END CAP AFTER ASSEMBLY (2)

1/2" LOCK NUT (8)

NUT COVER (8)

BOLT COVER (8)

1/2 X 4-3/4" BOLT (8)  
PRE-INSTALLED

XCREATE-4SX (2)

XCREATE-U-8DS

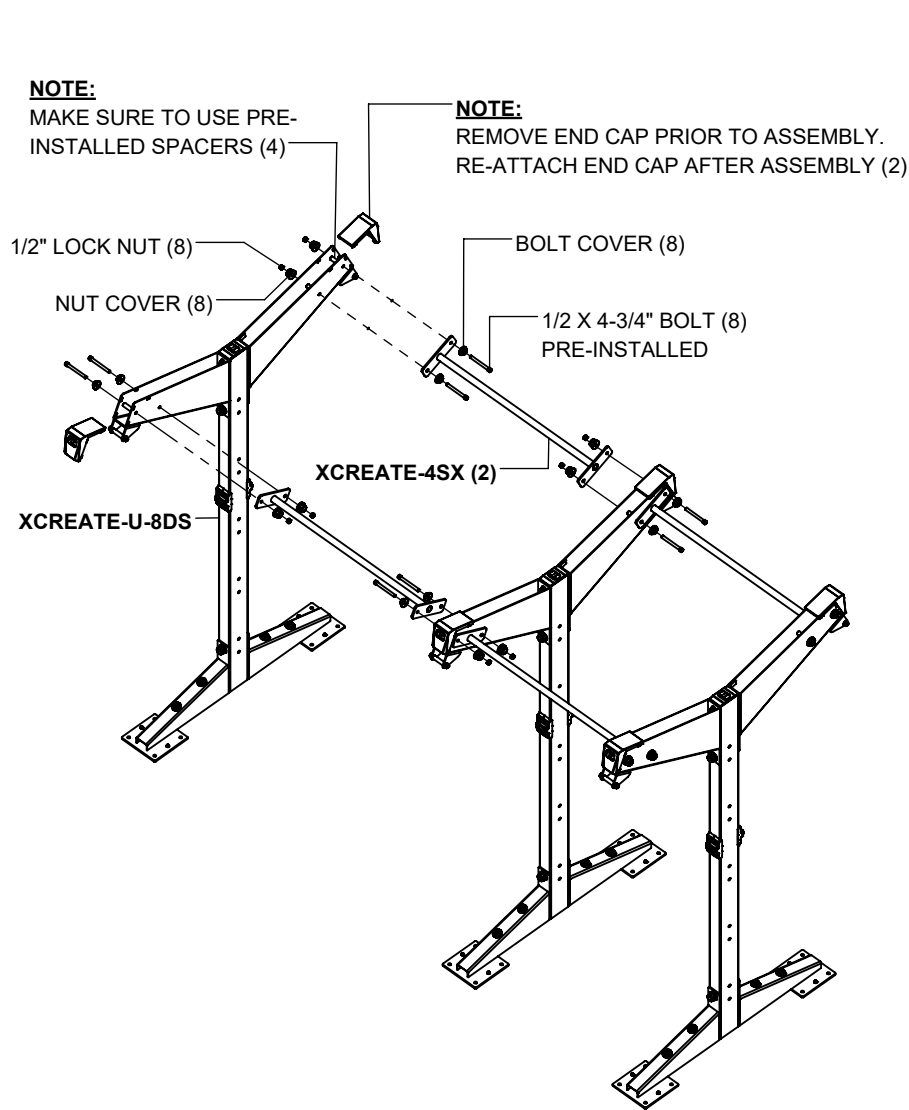

XCREATE-4SX

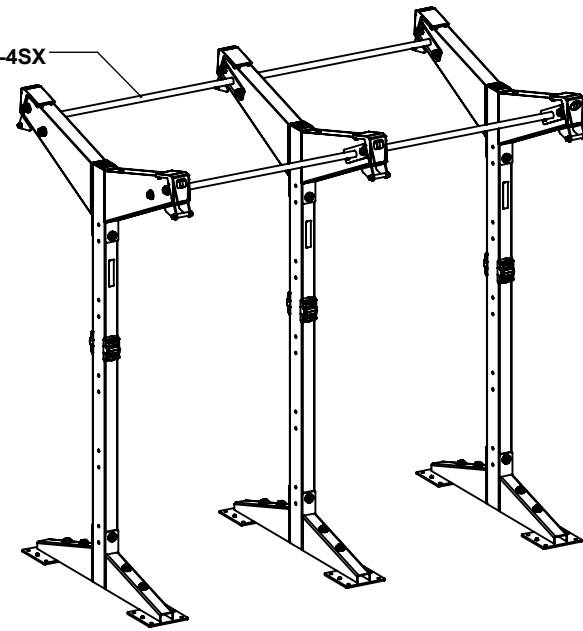

XCREATE-6SX

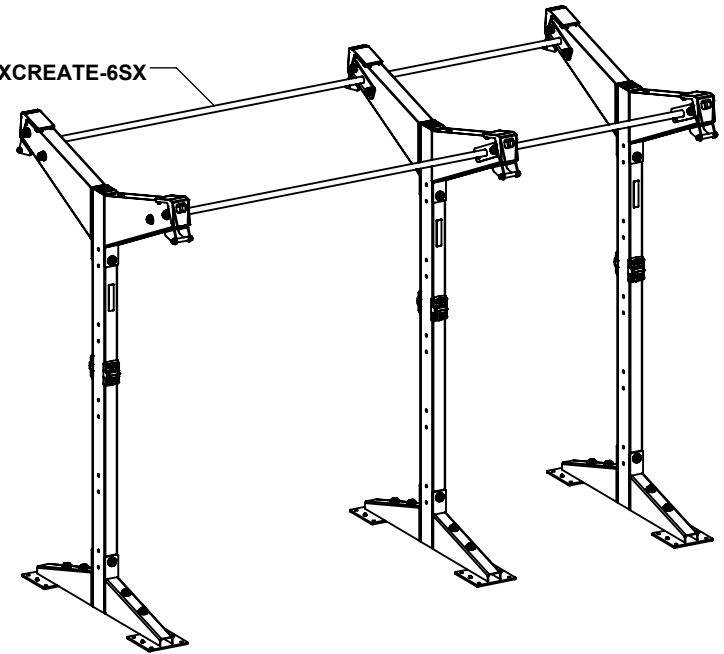

**NOTES:**

For the purpose of illustration the 4' module extension is shown. The 6' module extension is assembled the same way.

**LOOSELY** assemble bolt connections in this step.

Repeat this step for as many modules there are to assemble.

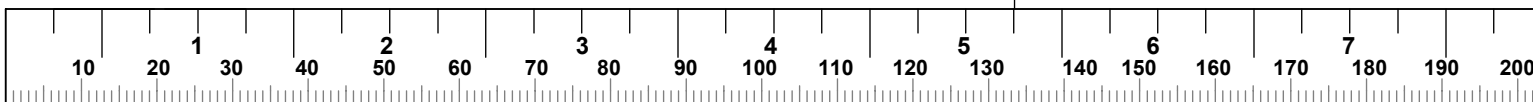

**4' / 6' STORAGE MODULE**

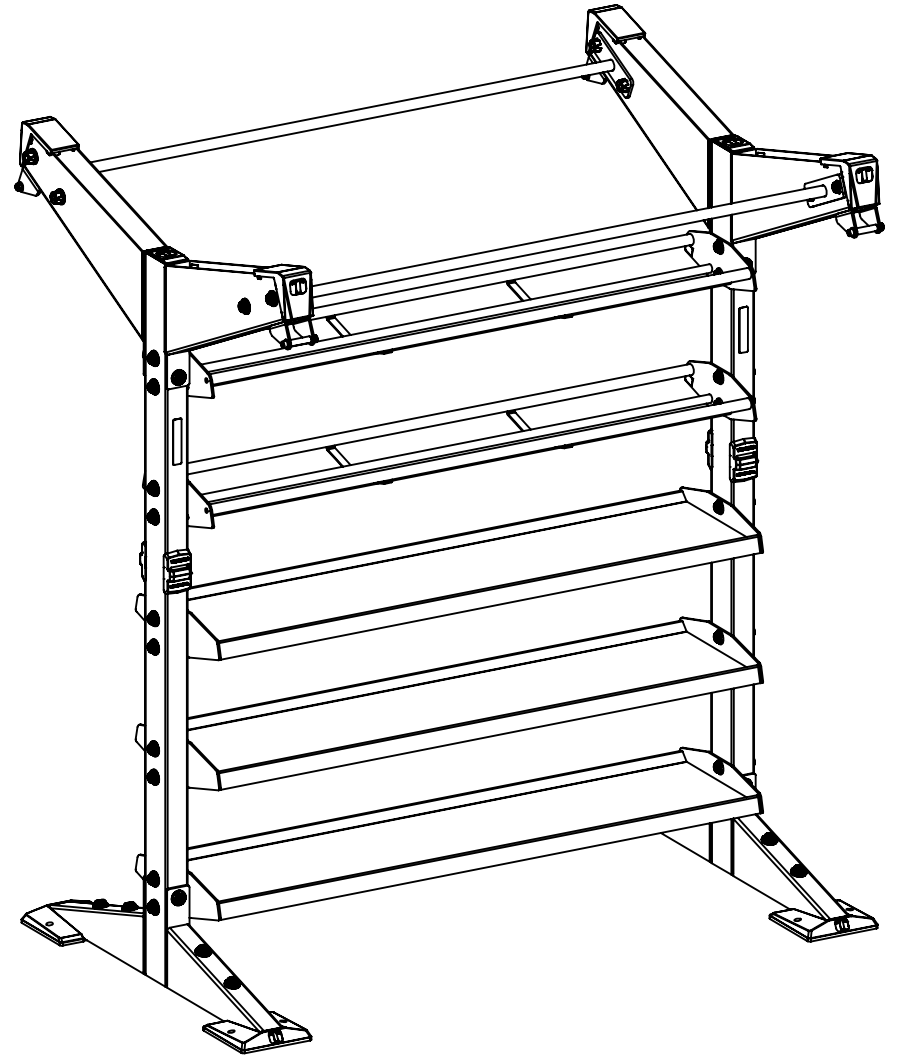
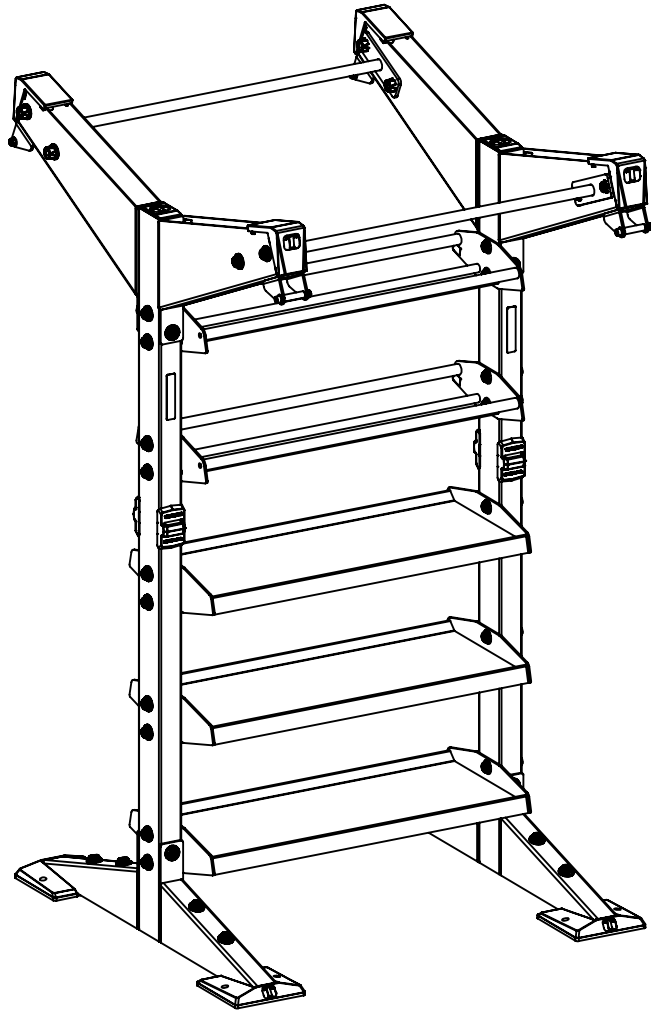

# 4' / 6' STORAGE MODULE

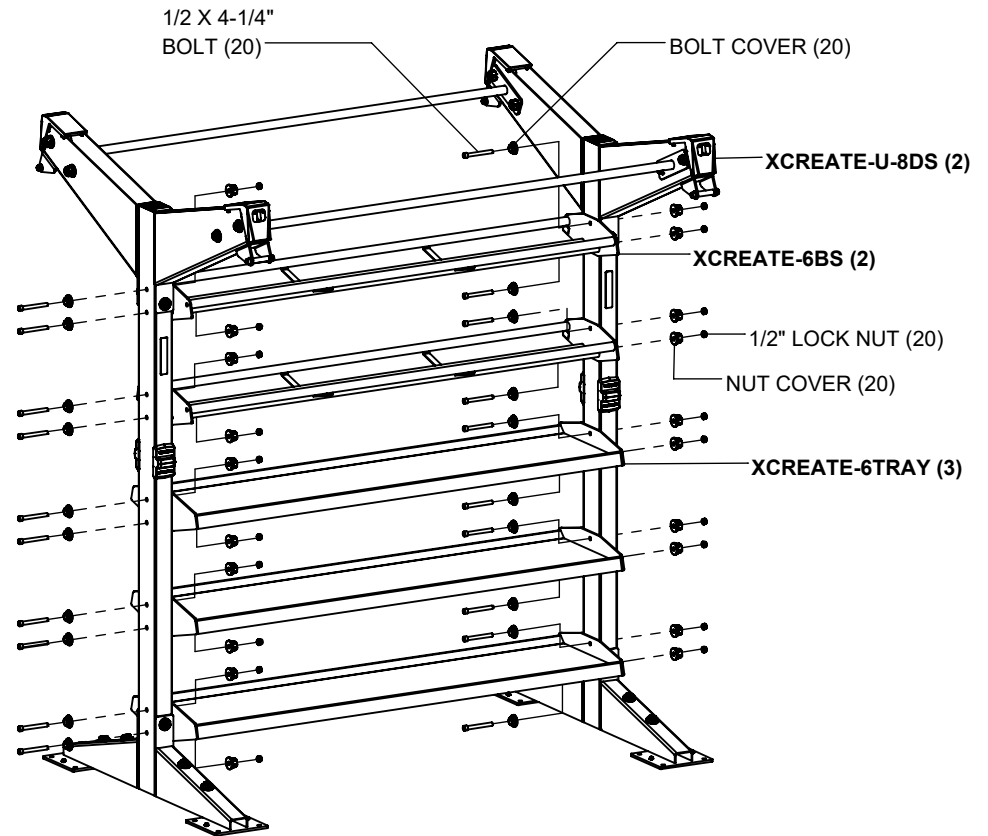
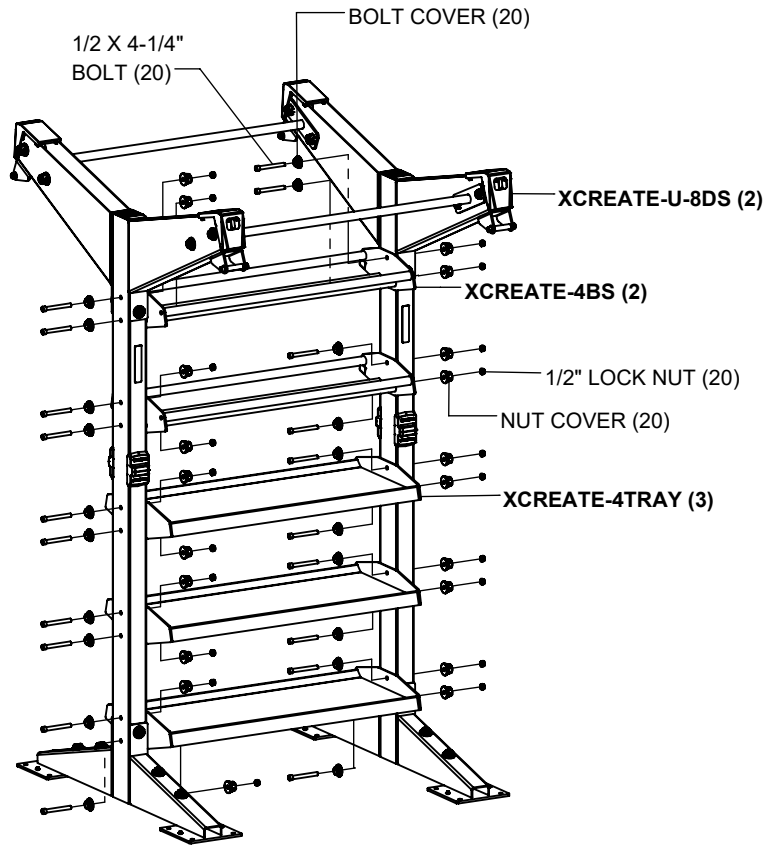

## NOTES:

If more modules will be assembled, do not tighten bolts at this time. If this is the only module being assembled, then **SECURELY** tighten all bolts in this step and previous steps.

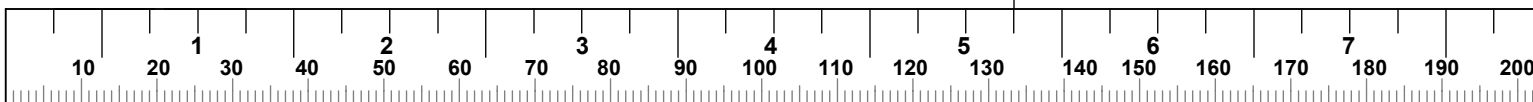

**4' / 6' UNIVERSAL BALL & HANGING  
STORAGE MODULE**

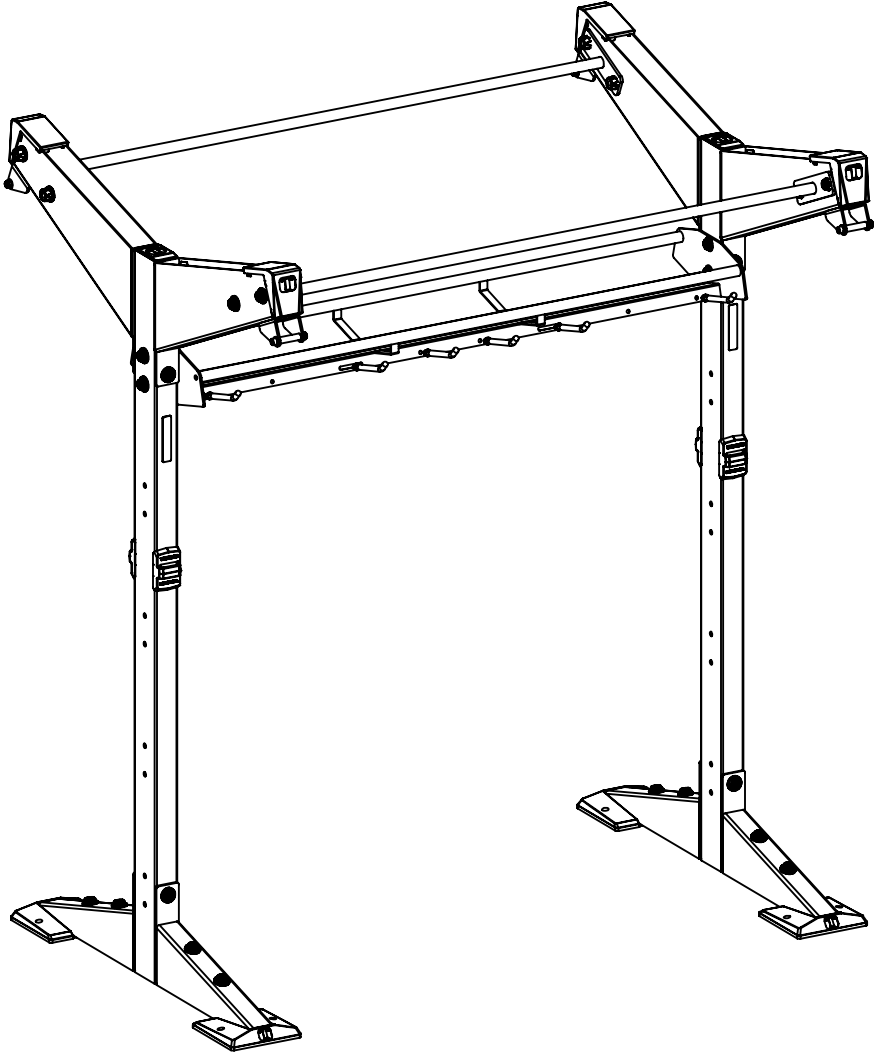
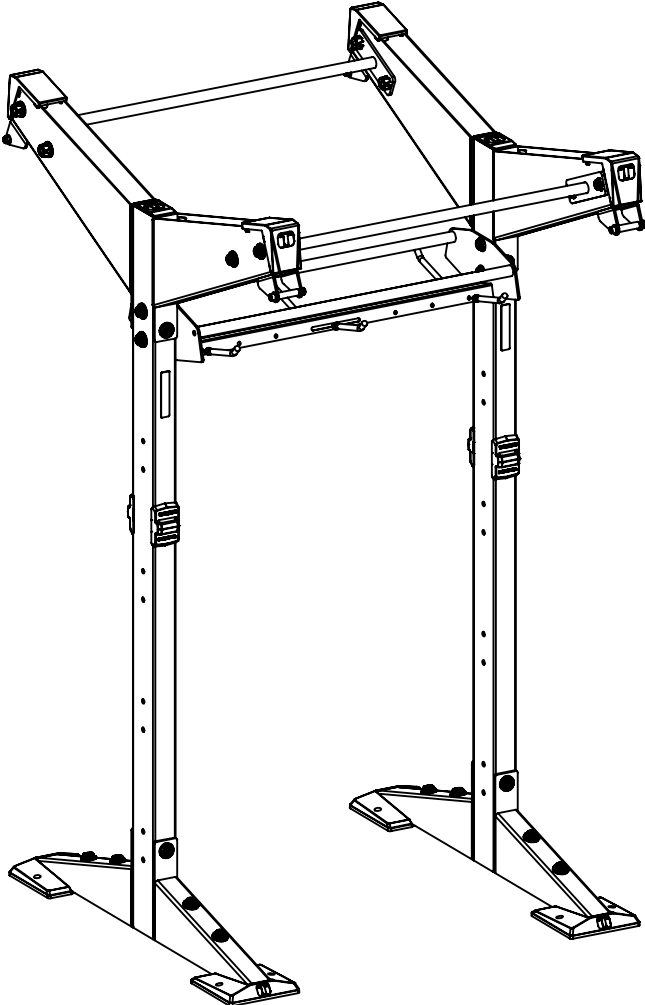

# 4' / 6' UNIVERSAL BALL & HANGING STORAGE MODULE

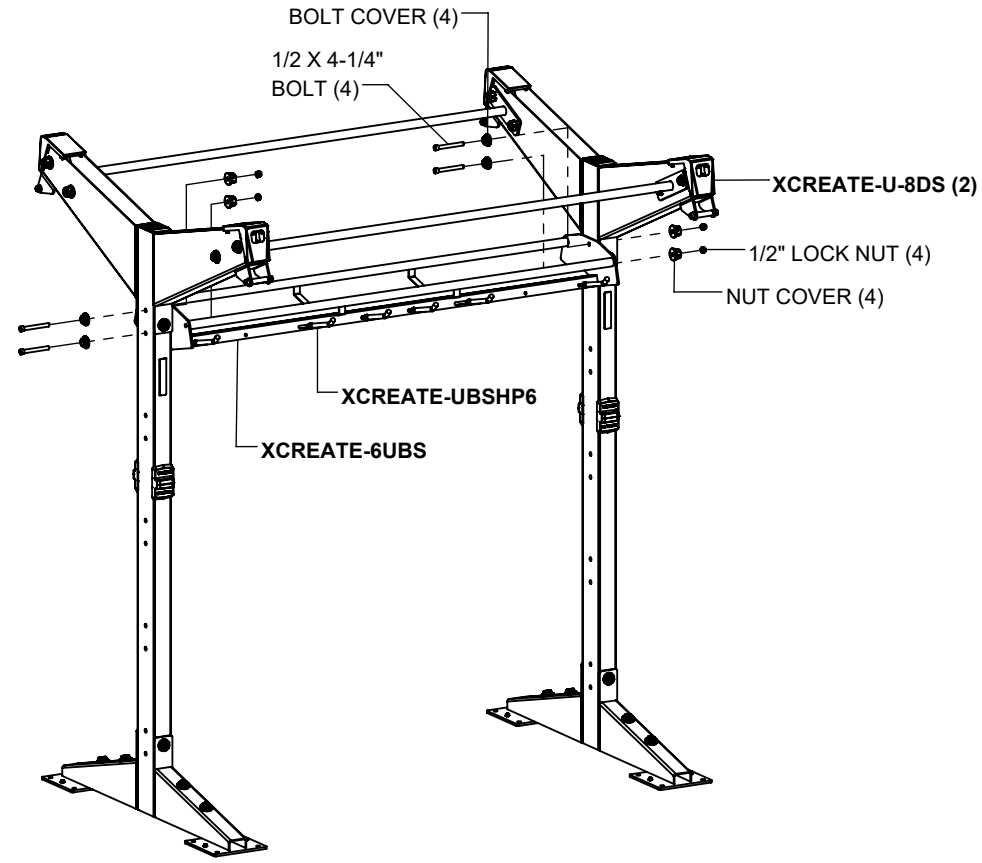
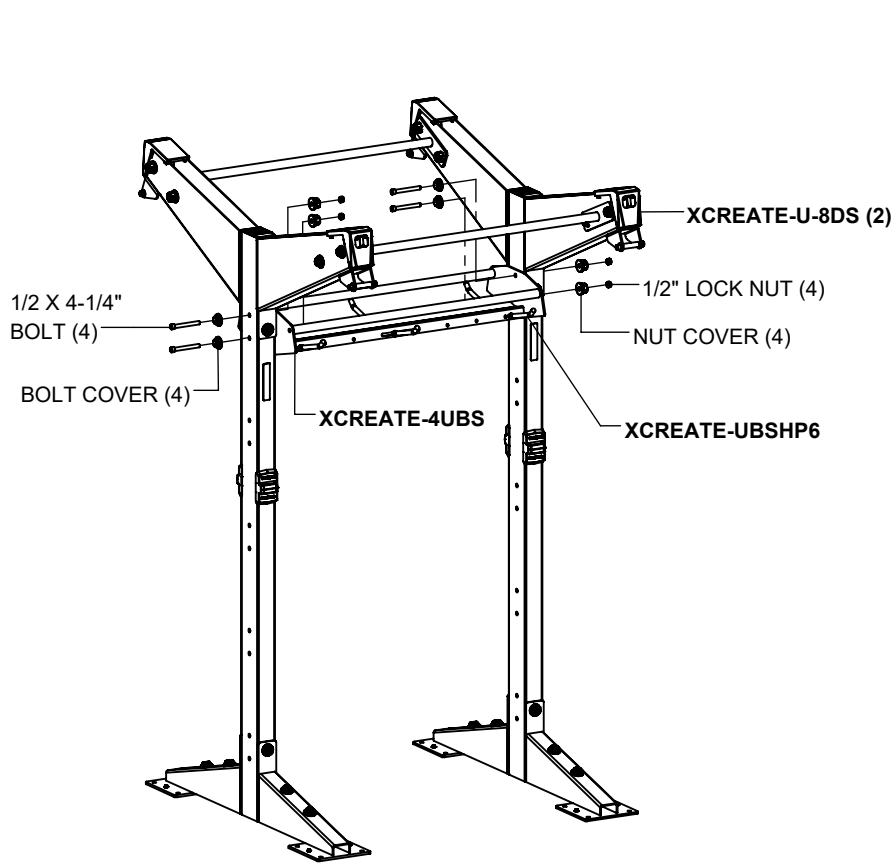

## NOTES:

If more modules will be assembled, do not tighten bolts at this time. If this is the only module being assembled, then **SECURELY** tighten all bolts in this step and previous steps.

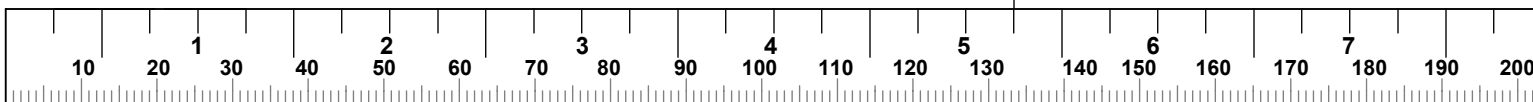

**4' STALL BAR MODULE**

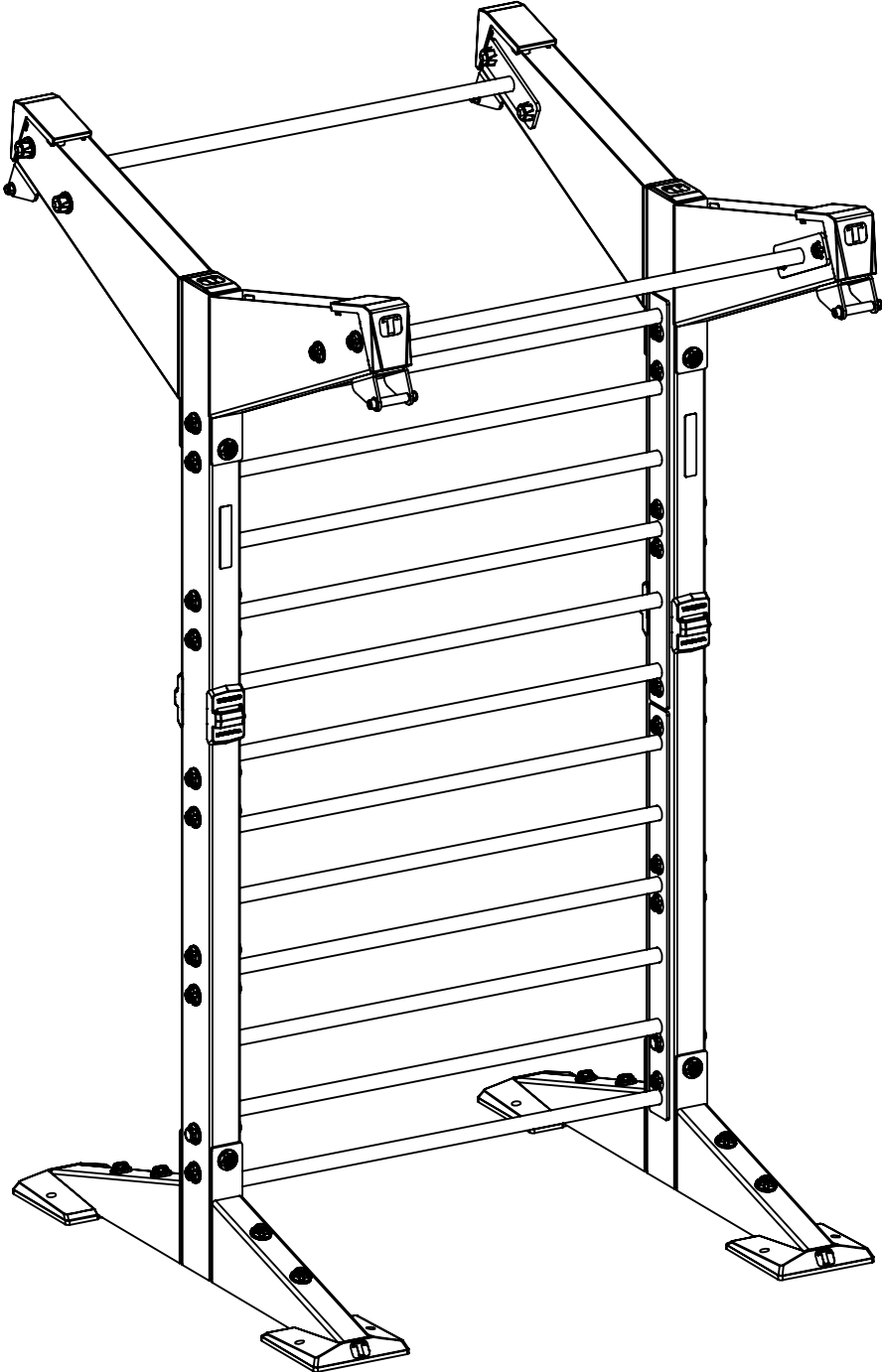

# 4' STALL BAR MODULE

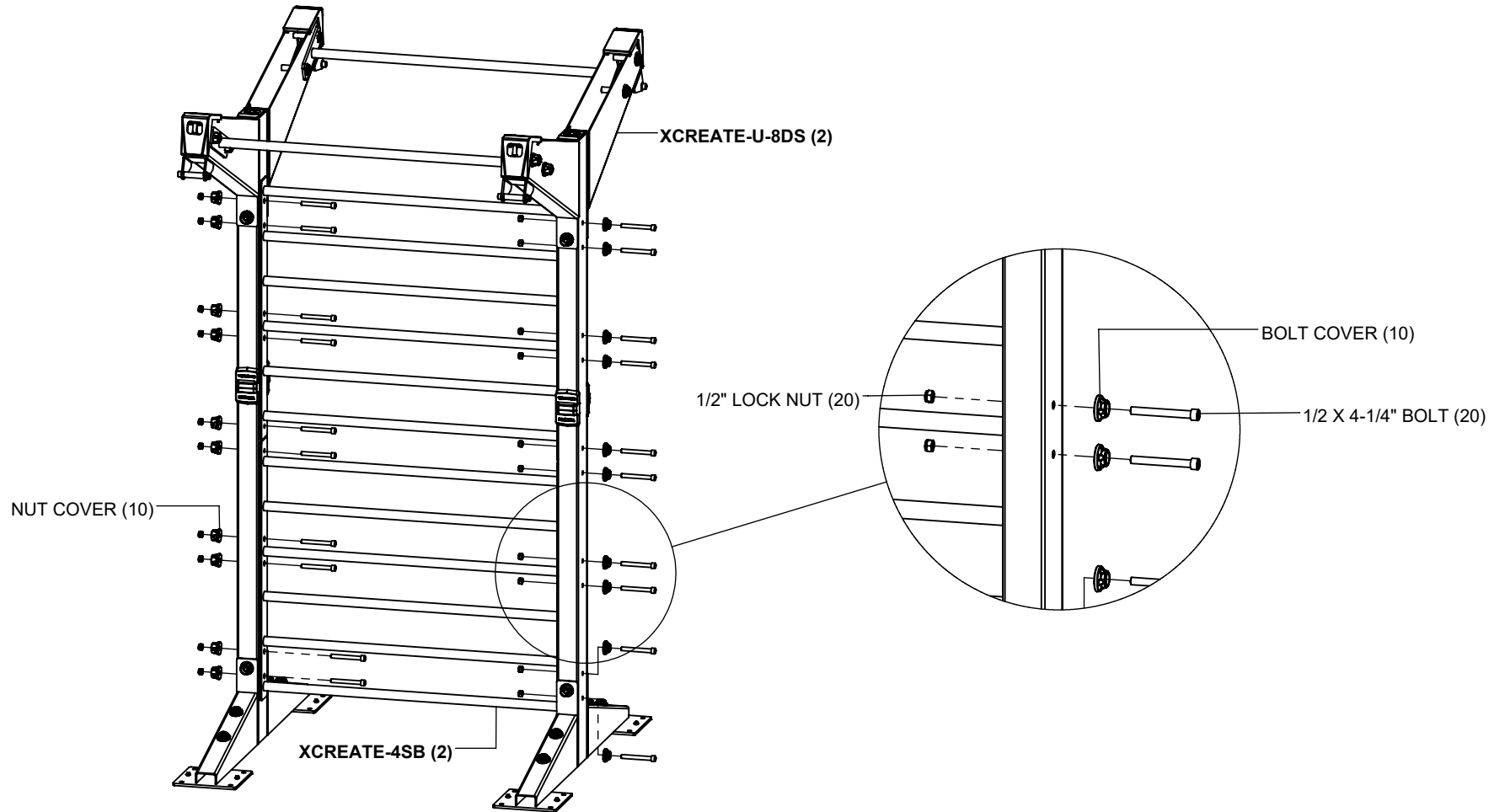

## NOTES:

If more modules will be assembled, do not tighten bolts at this time. If this is the only module being assembled, then **SECURELY** tighten all bolts made in this step and previous steps.

(\*) **HARDWARE COVERS CAN** be used in place of washers on **tube side only**. (SEE PAGE 3).

(\*\*) **HARDWARE COVERS CANNOT** be used on plate side.

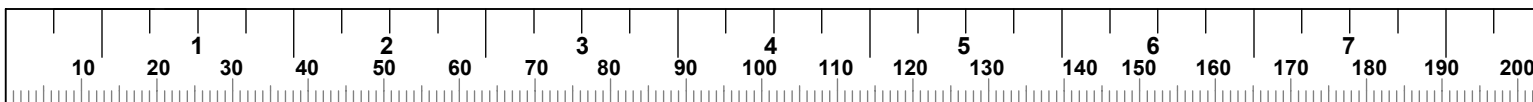

**4' BALL TARGET WALL PAD MODULE**

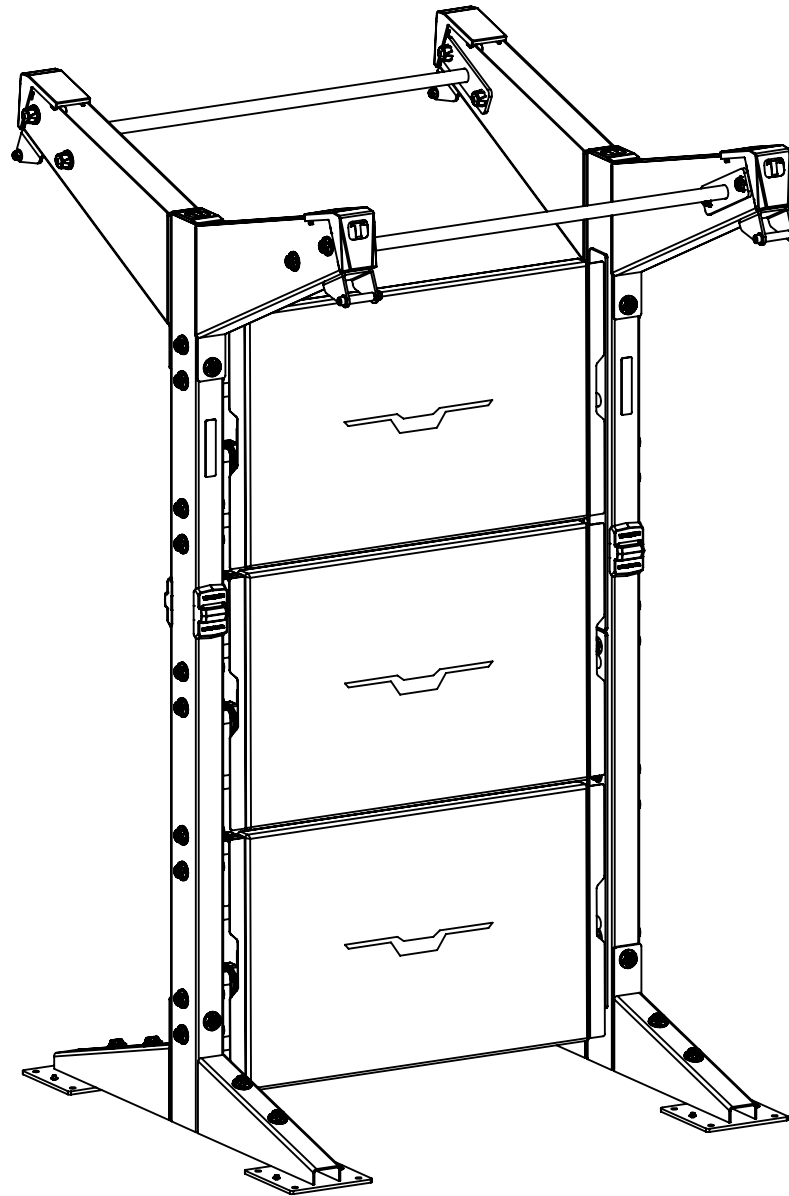

## 4' BALL TARGET WALL PADS

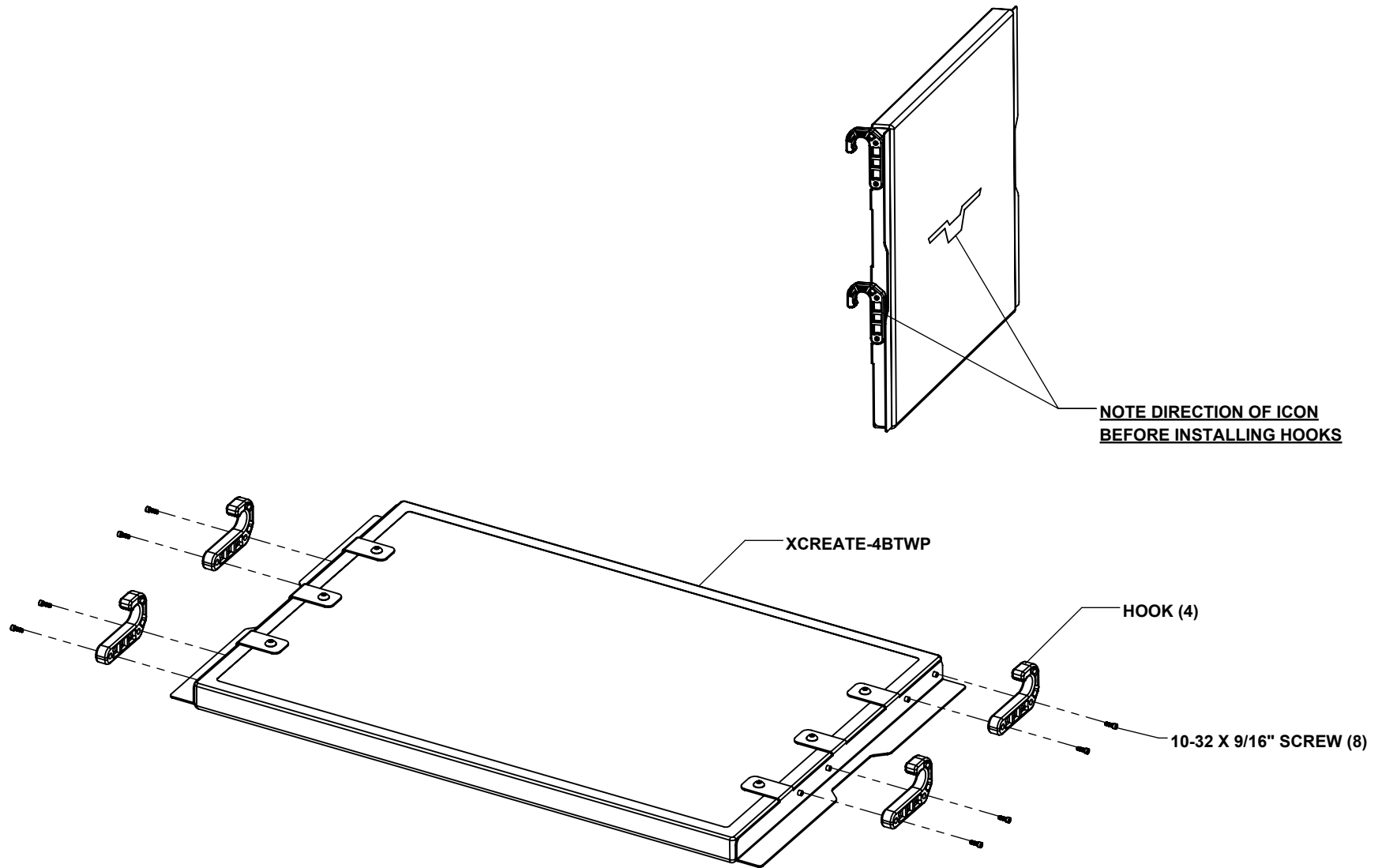

### NOTES:

**SECURELY TIGHTEN, DO NOT OVER TIGHTEN** all bolted connections in this step.

Repeat this step for all ball target pads.

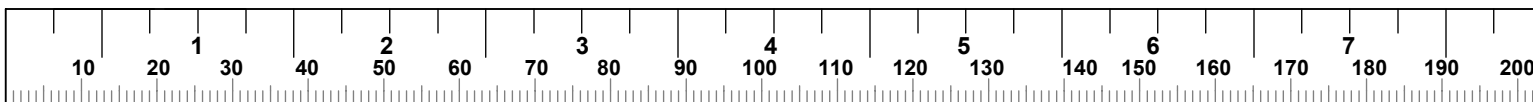

## 4' BALL TARGET WALL PAD MODULE

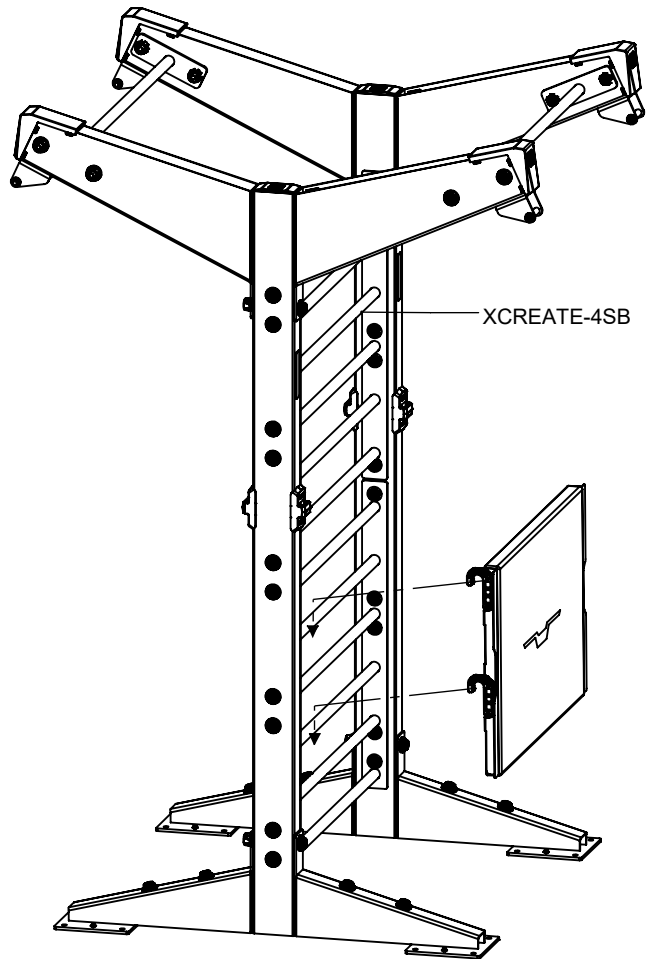

XCREATE-4SB

**NOTE:**  
ALIGN AND HOOK BALL  
TARGET PADS OVER STALL  
BAR CROSSMEMBERS.  
PRESS PAD DOWN TO LOCK  
INTO PLACE

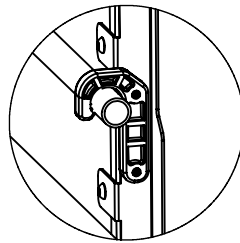

ASSEMBLED  
SECTION VIEW

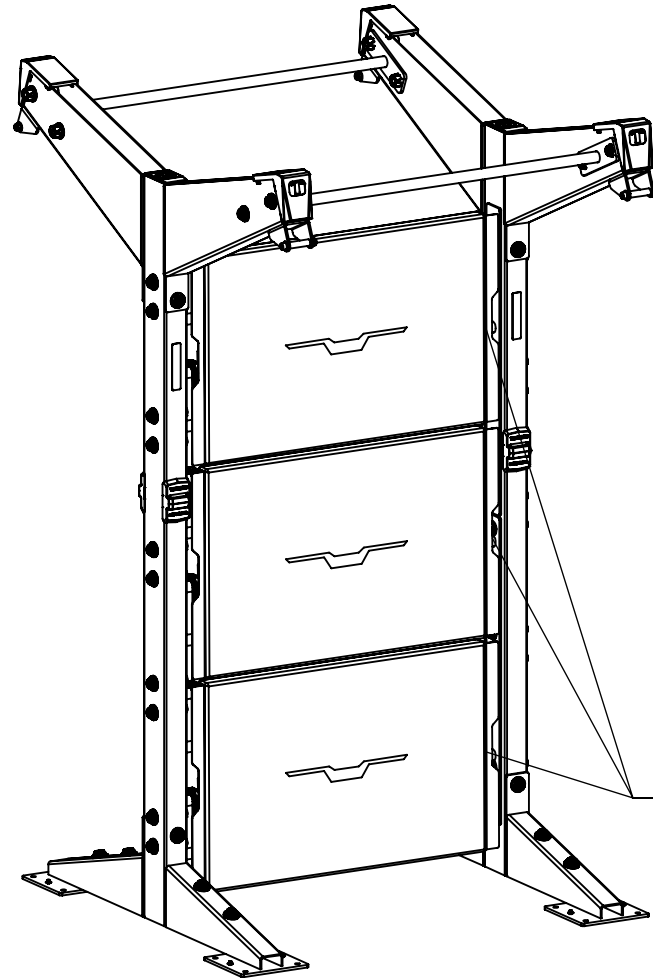

**NOTE:**  
WHEN INSTALLING MULTIPLE  
PADS ALWAYS START WITH  
THE LOWEST PAD.

### **NOTES:**

**XCREATE 4' STALL BAR MODULE** is required for installing the ball target wall pads. Reference previous steps for installing the stall bars.

Ball target wall pads can be removed and replaced as needed.

## **4' BALL TARGET WALL PADS**

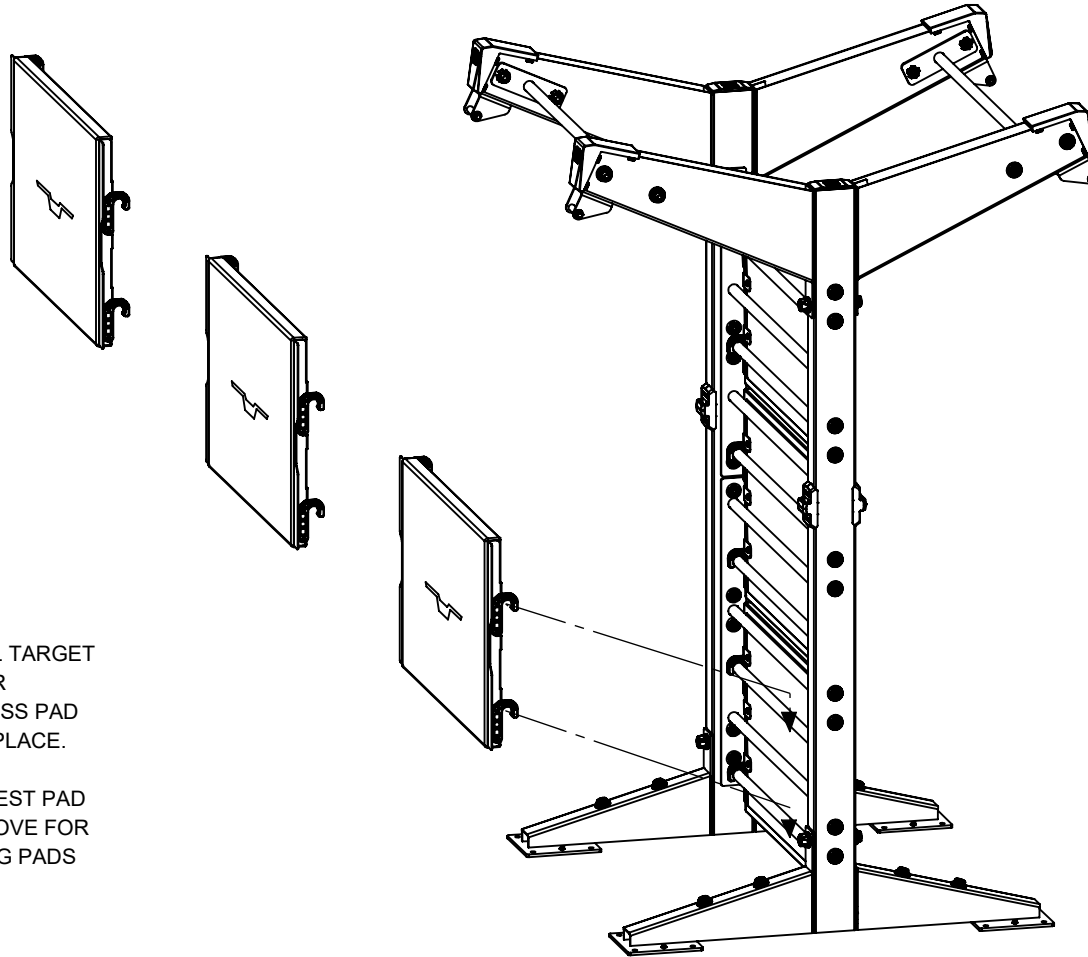

**NOTE:**

ALIGN AND HOOK BALL TARGET PADS OVER STALL BAR CROSSMEMBERS. PRESS PAD DOWN TO LOCK INTO PLACE.

START WITH THE LOWEST PAD AND REPEAT STEP ABOVE FOR INSTALLING REMAINING PADS

**NOTES:**

**XCREATE 4' STALL BAR MODULE** is required for installing the ball target wall pads. Reference previous steps for installing the stall bars.

Ball target wall pads can be removed and replaced as needed.

**8' OLYMPIC LIFTING STATION MODULE**

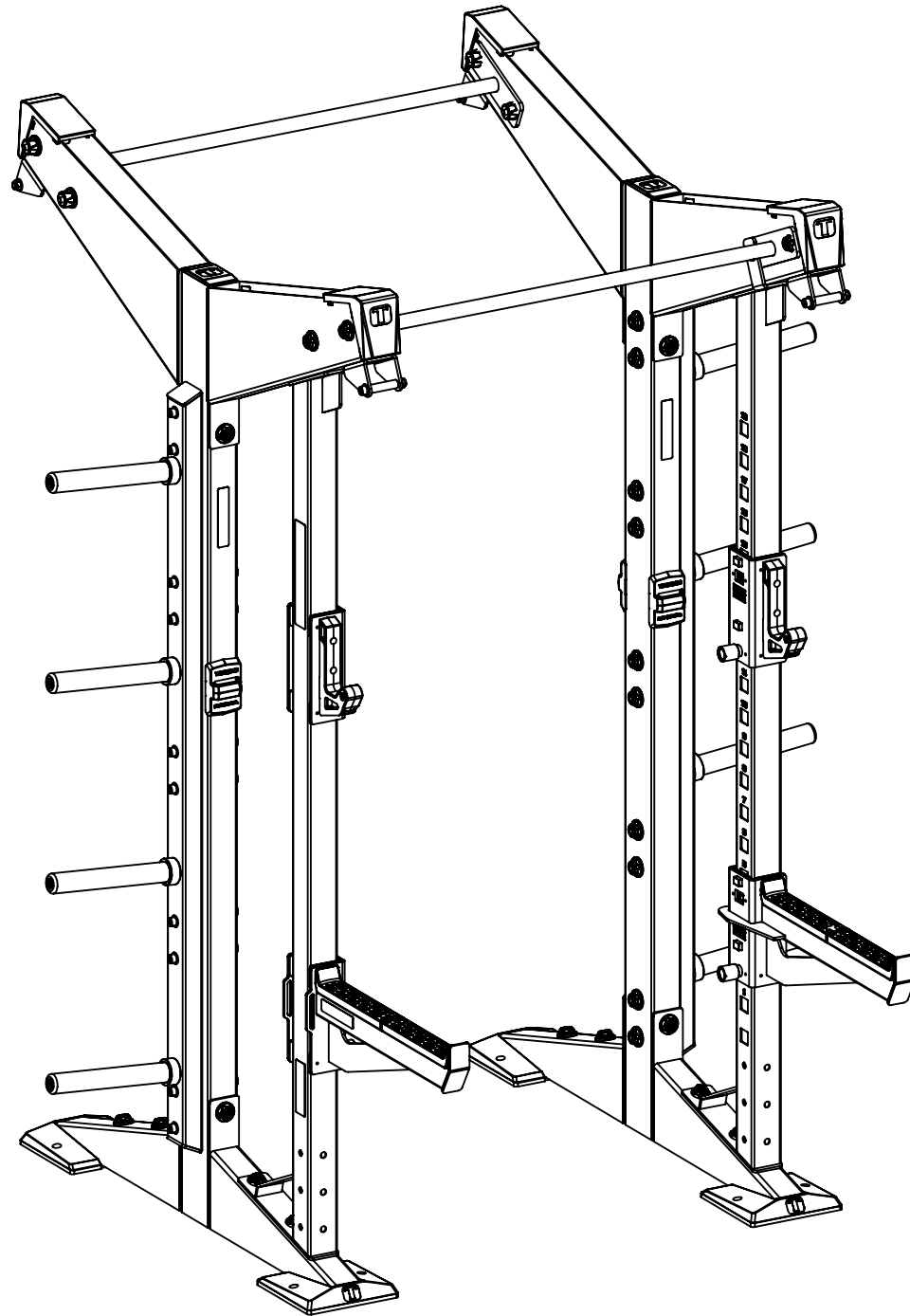

# 8' OLYMPIC LIFTING STATION MODULE

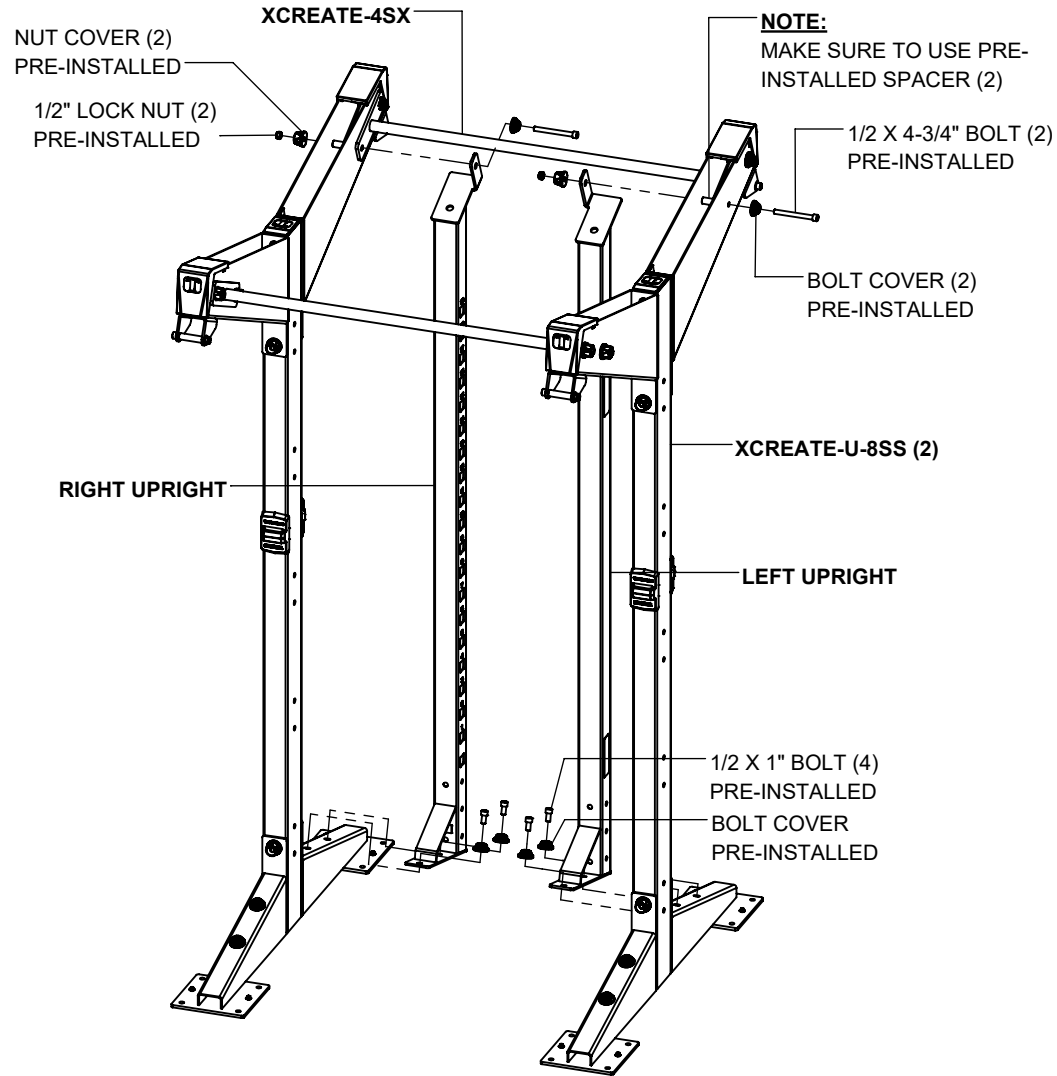

## NOTES:

**SECURELY** tighten all bolt connections in this step.

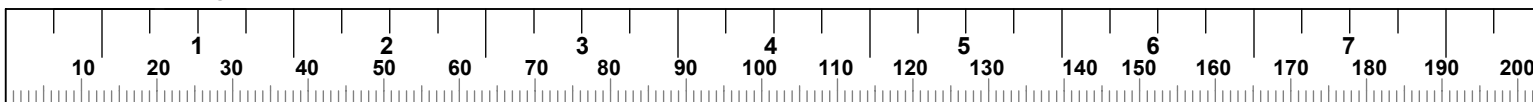

# 8' OLYMPIC LIFTING STATION MODULE

**NOTE:**  
INSERT BAR SUPPORTS INTO  
DESIRED SLOTS ON UPRIGHTS.  
PUSH DOWN TO LOCK IN PLACE

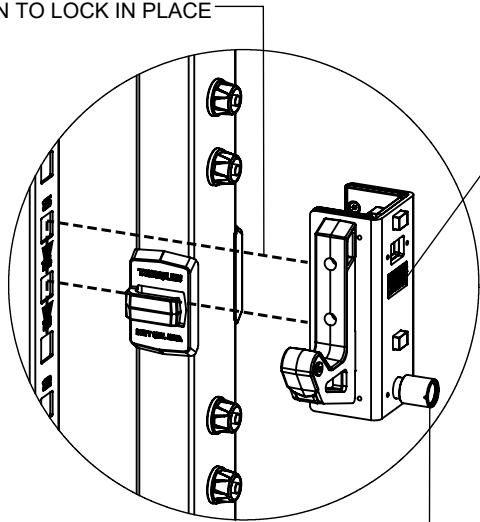

**NOTE:**  
WARNING LABEL

**NOTE:**  
TO REMOVE BAR SUPPORTS FROM  
UPRIGHTS, PULL SPRING PIN OUT TO  
UNLOCK. LIFT UP AND PULL OUT

LEFT UPRIGHT

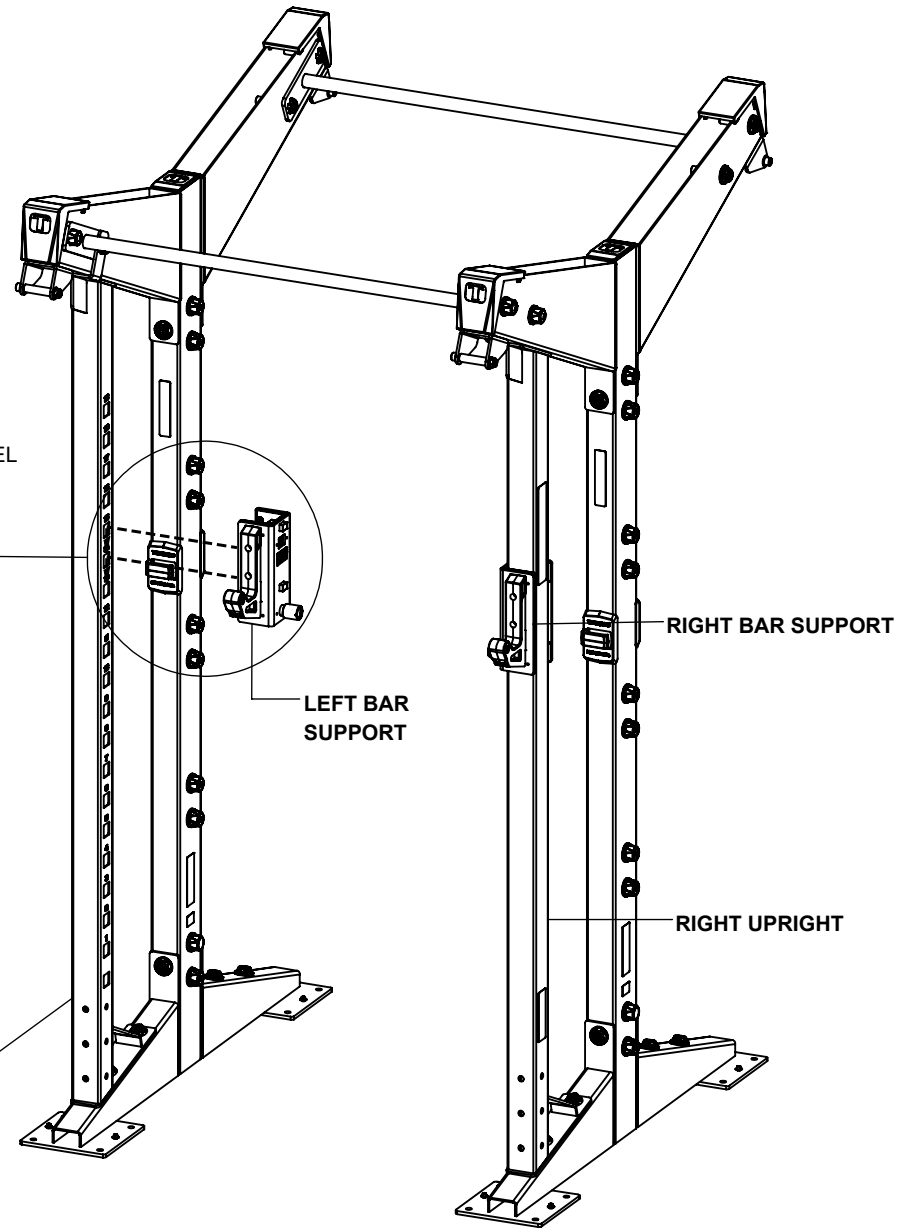

# 8' OLYMPIC LIFTING STATION MODULE

**NOTE:**  
INSERT BAR CATCHES INTO  
DESIRED SLOTS ON UPRIGHTS.  
PUSH DOWN TO LOCK IN PLACE

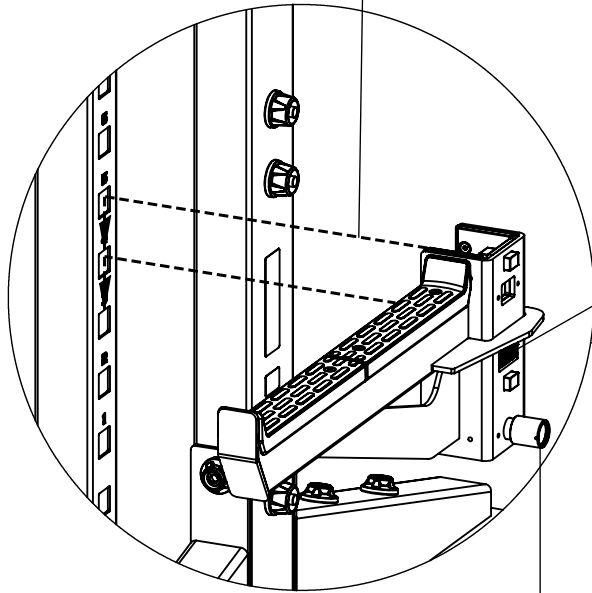

**NOTE:**  
WARNING LABEL

**NOTE:**  
TO REMOVE BAR CATCHES FROM  
UPRIGHTS, PULL SPRING PIN OUT TO  
UNLOCK. LIFT UP AND PULL OUT

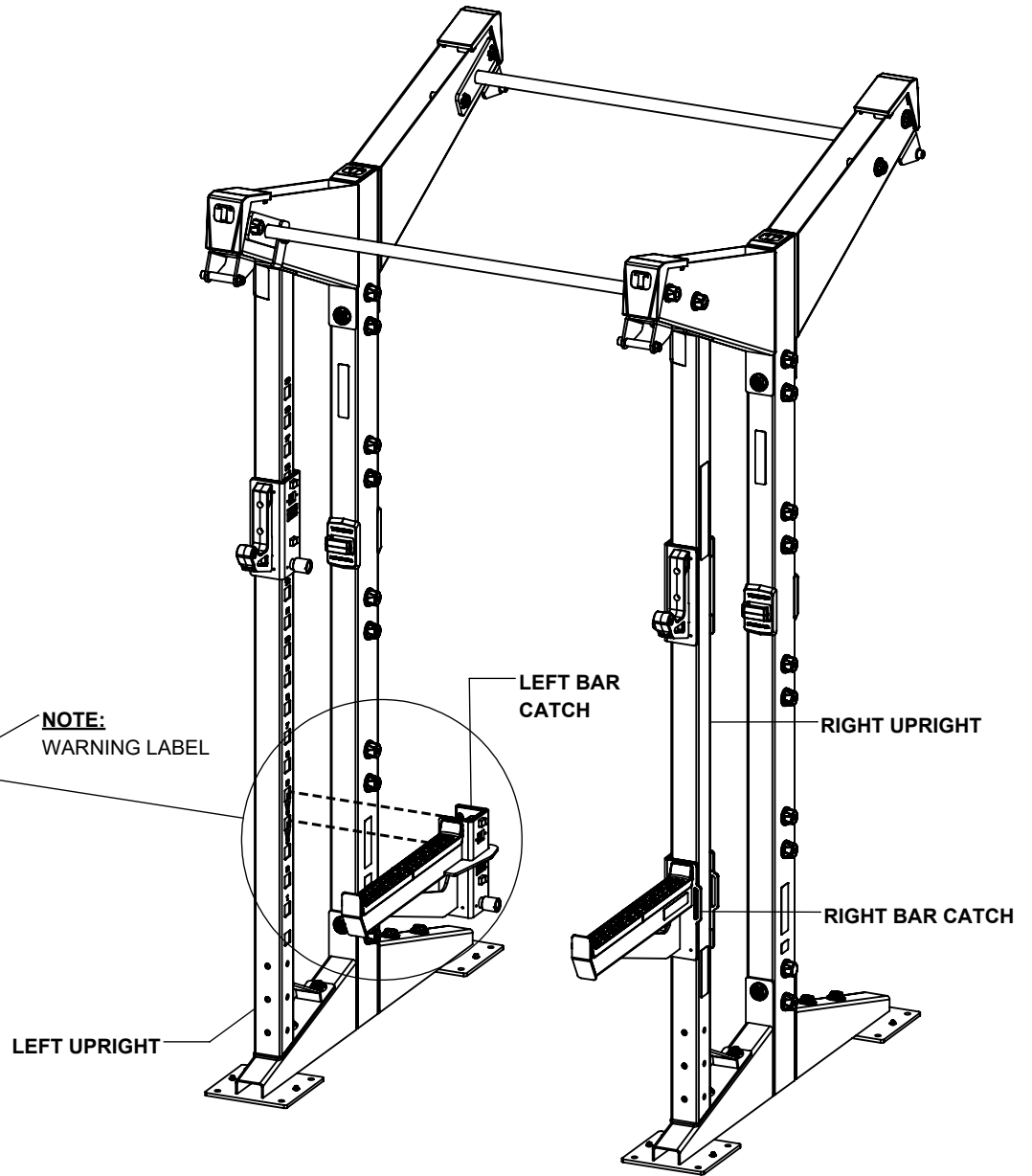

# 8' OLYMPIC LIFTING STATION MODULE

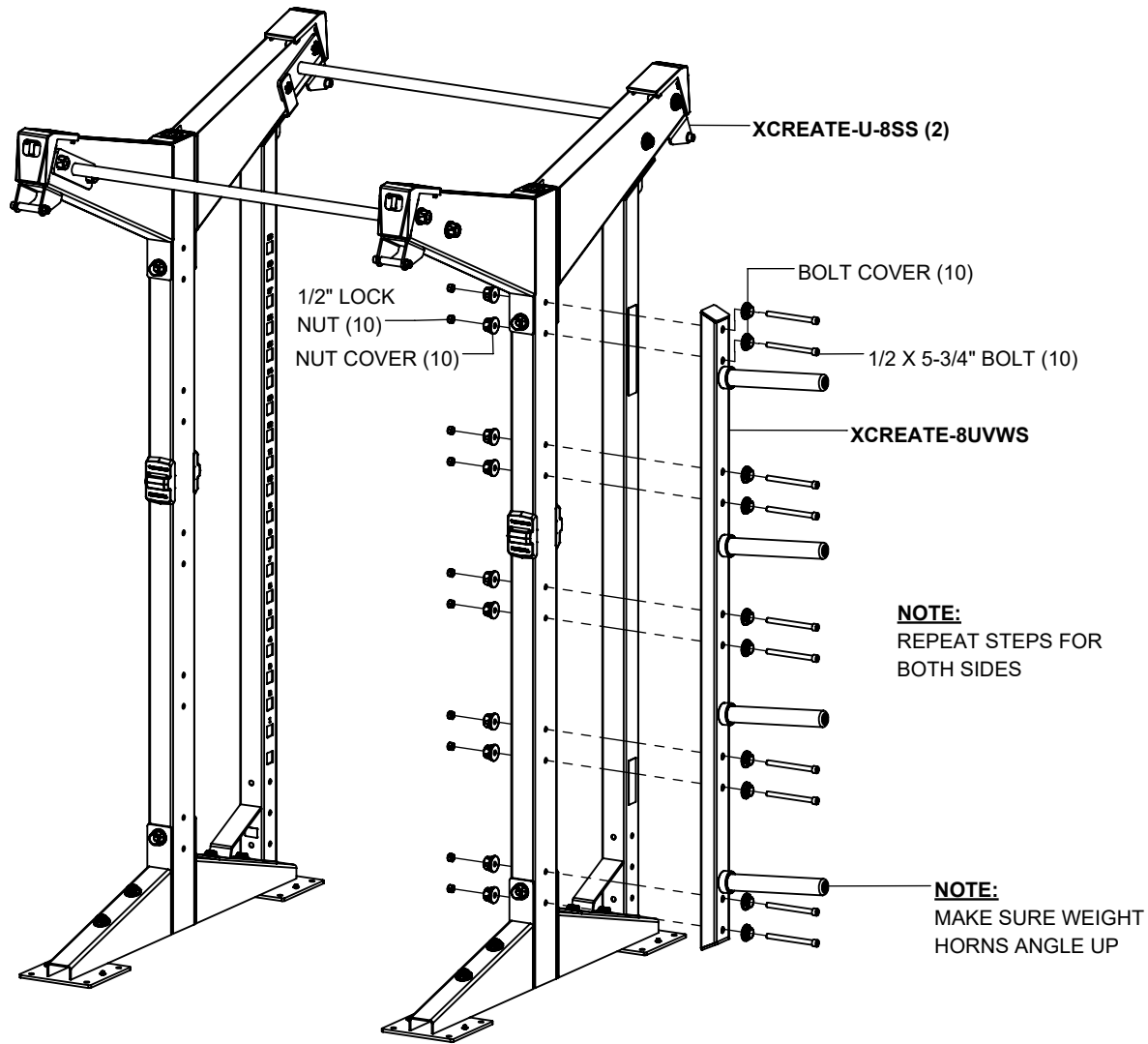

## NOTES:

**SECURELY** tighten all bolt connections in this step.

**REPEAT STEPS** for both sides as needed.

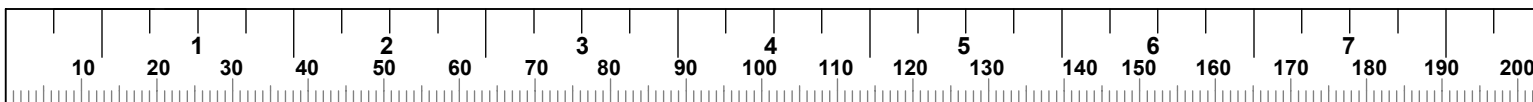

**4' / 6' ACCESSORY & BUMPER BOOKSHELF  
STORAGE MODULE**

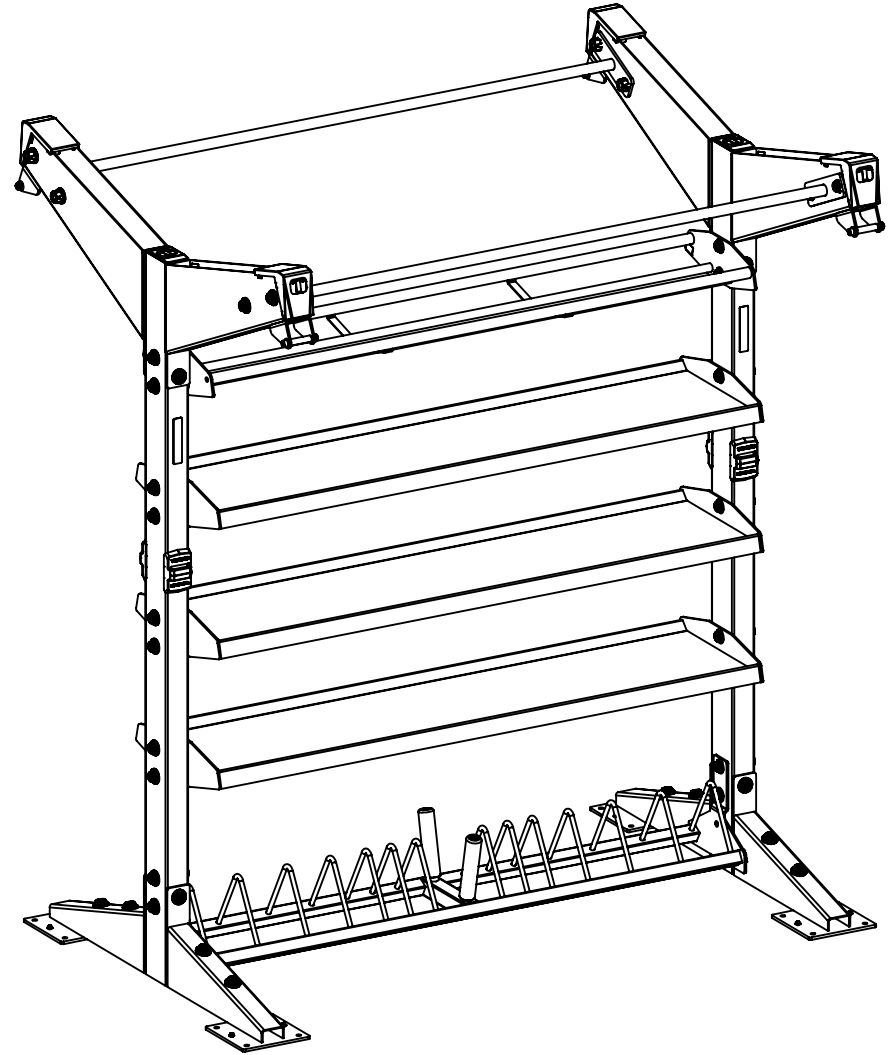
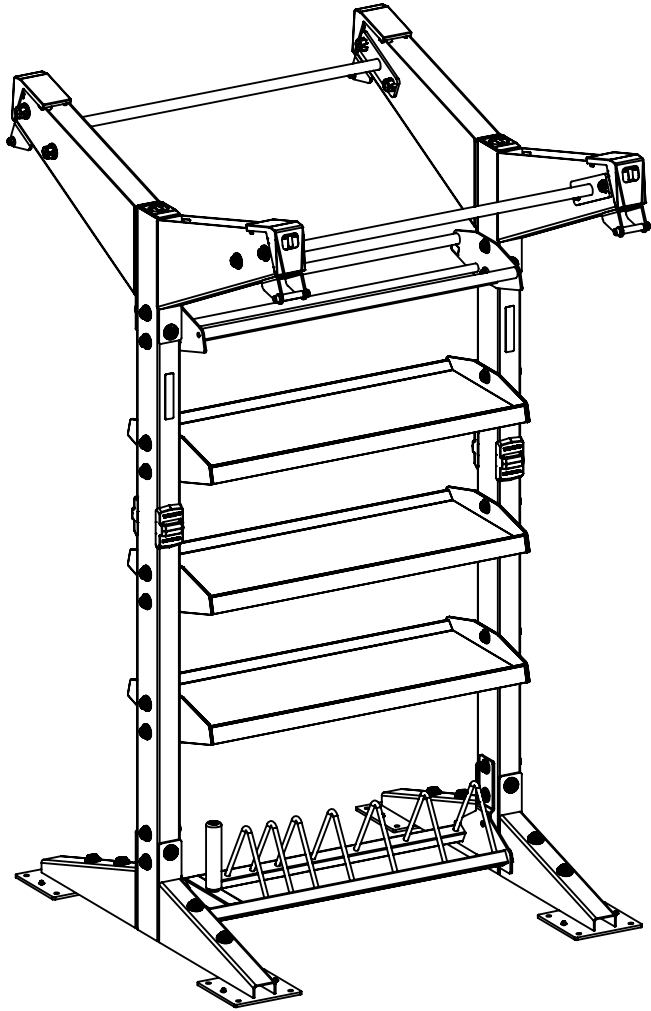

# 4' / 6' ACCESSORY & BUMPER BOOKSHELF STORAGE MODULE

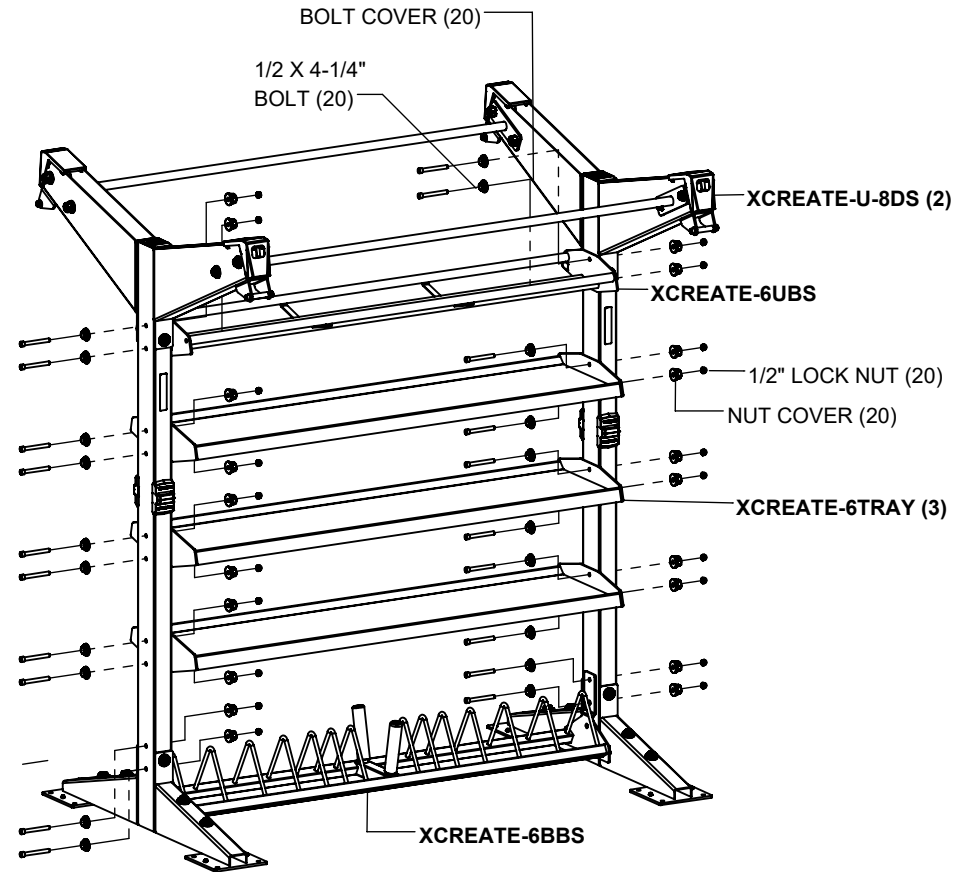
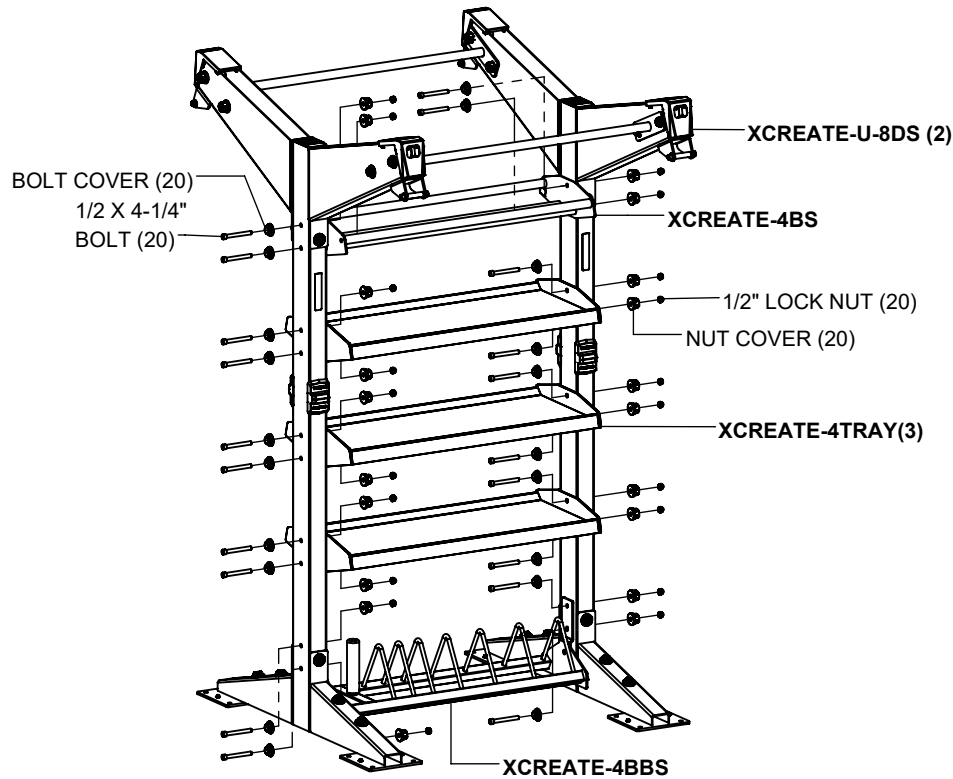

## NOTES:

If more modules will be assembled, do not tighten bolts at this time. If this is the only module being assembled, then **SECURELY** tighten all bolts in this step and previous steps.

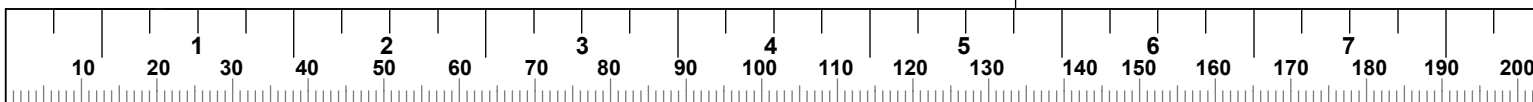

## **4' TANK DOCKING MODULE**

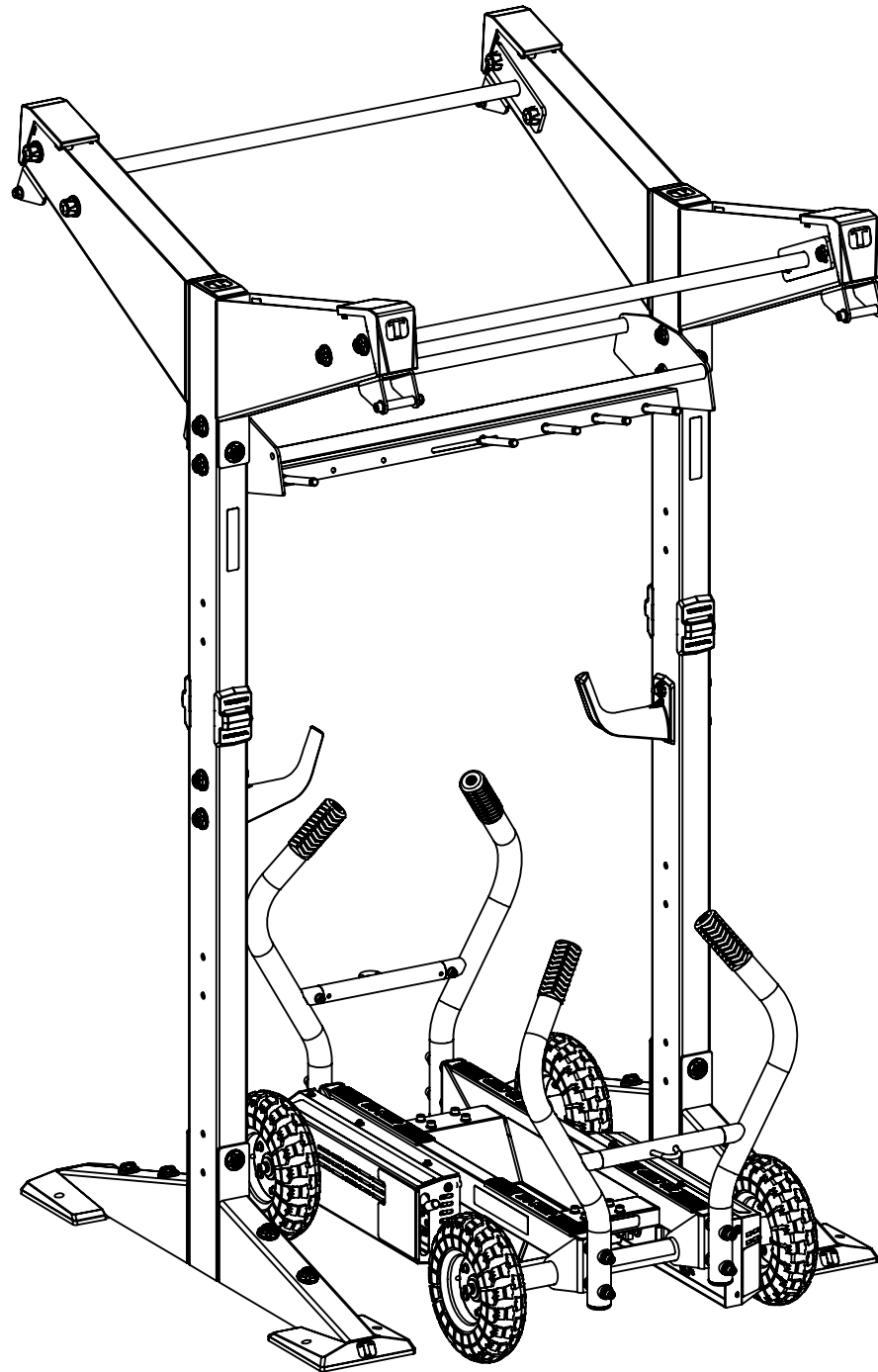

## 4' TANK DOCKING MODULE

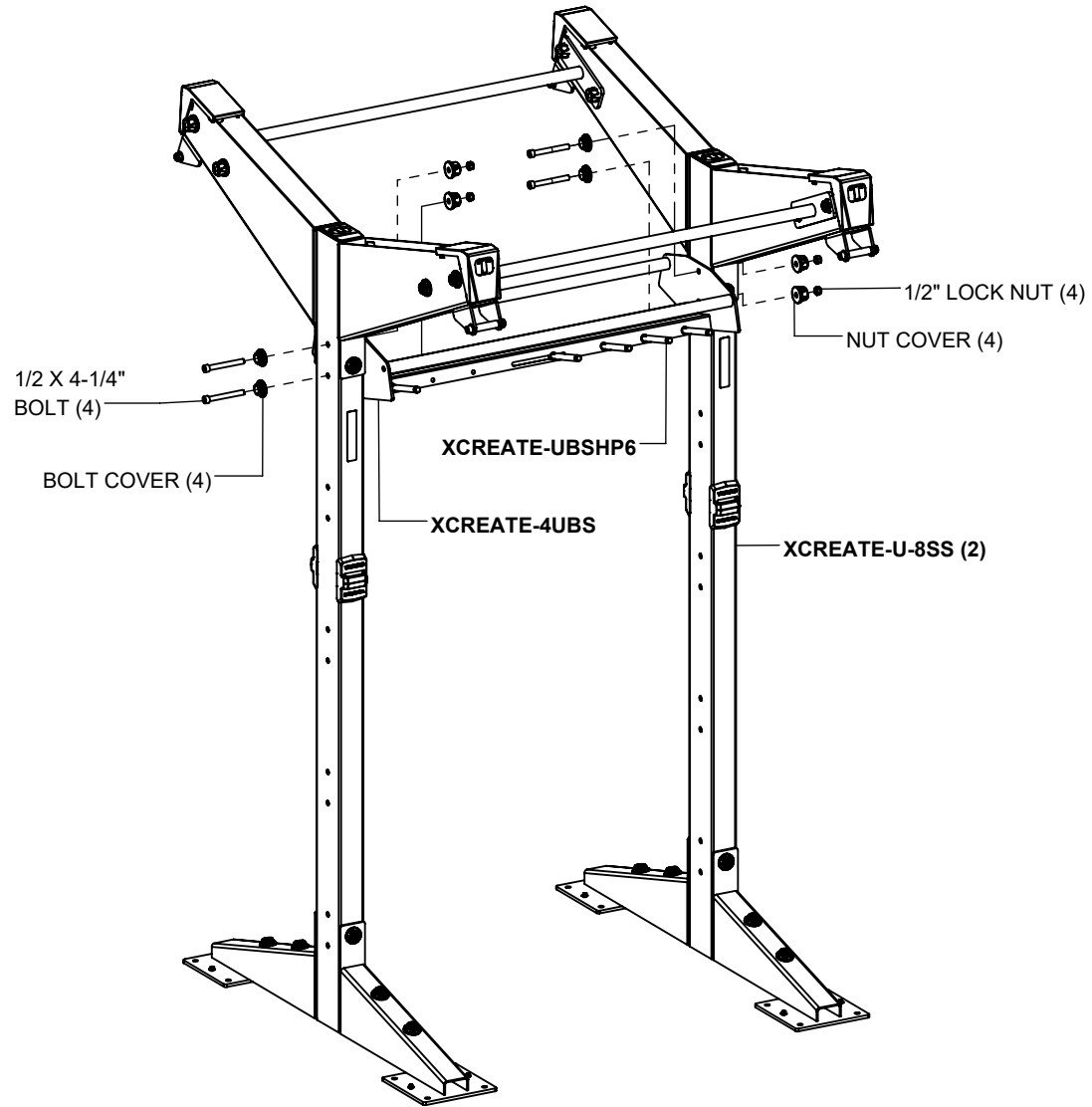

### NOTES:

If more modules will be assembled, do not tighten bolts at this time.  
If this is the only module being assembled, then **SECURELY** tighten all bolts in this step and previous steps.

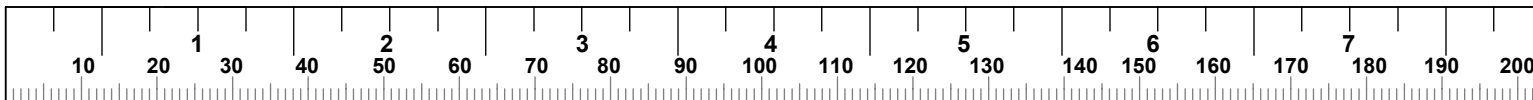

## 4' TANK DOCKING MODULE

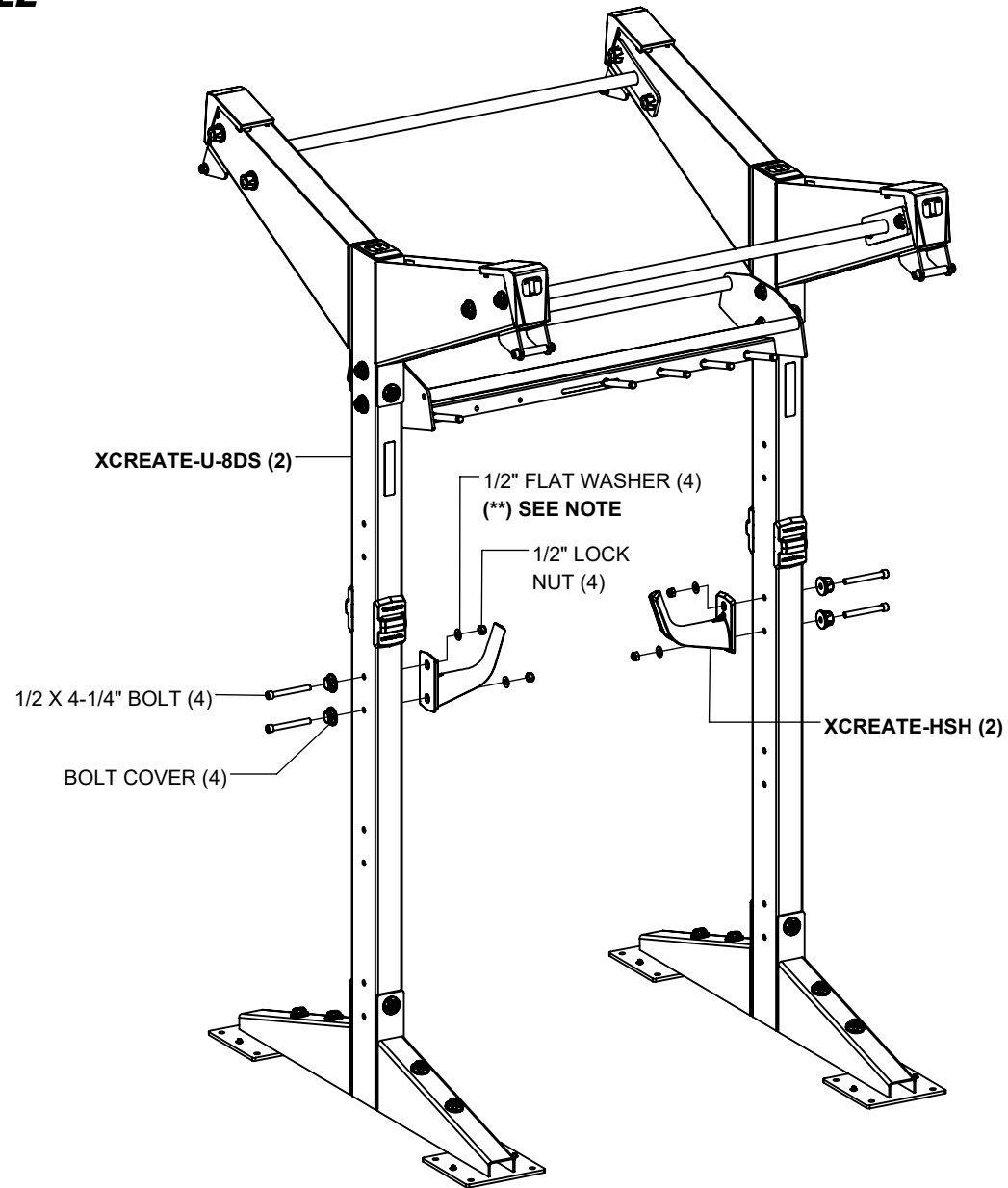

### NOTES:

**SECURELY** tighten all bolt connections in this step.

(\*\*) **HARDWARE COVER CANNOT** be used on **HSH** side.

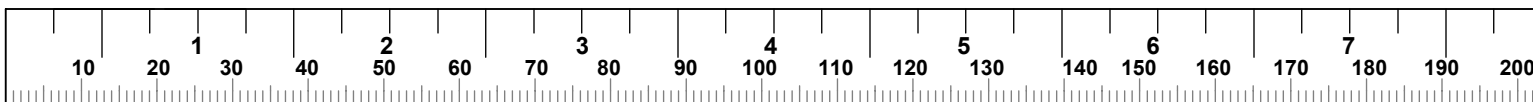

## 4' TANK DOCKING MODULE

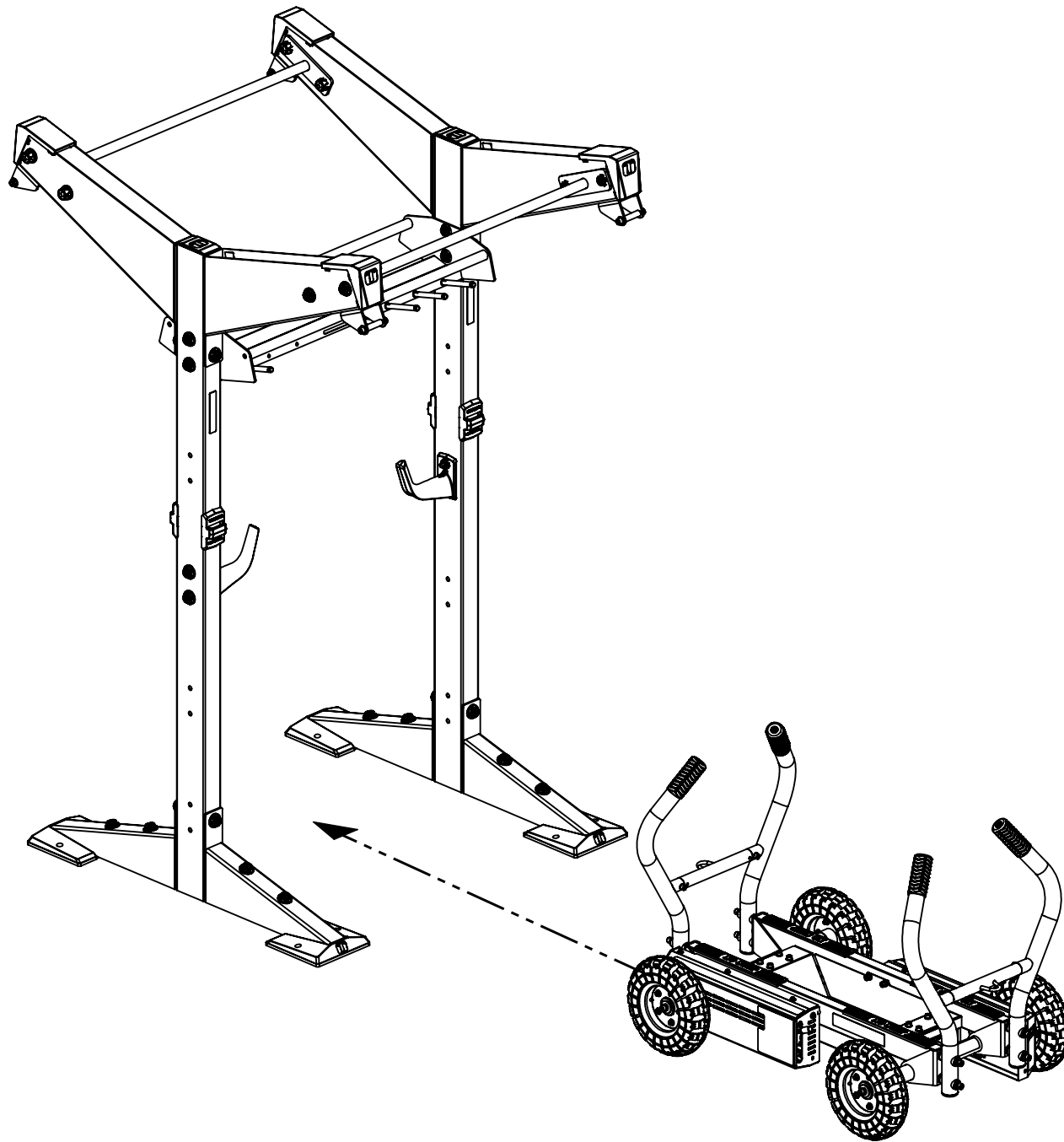

**4' X 5' BARBELL STORAGE MODULE**

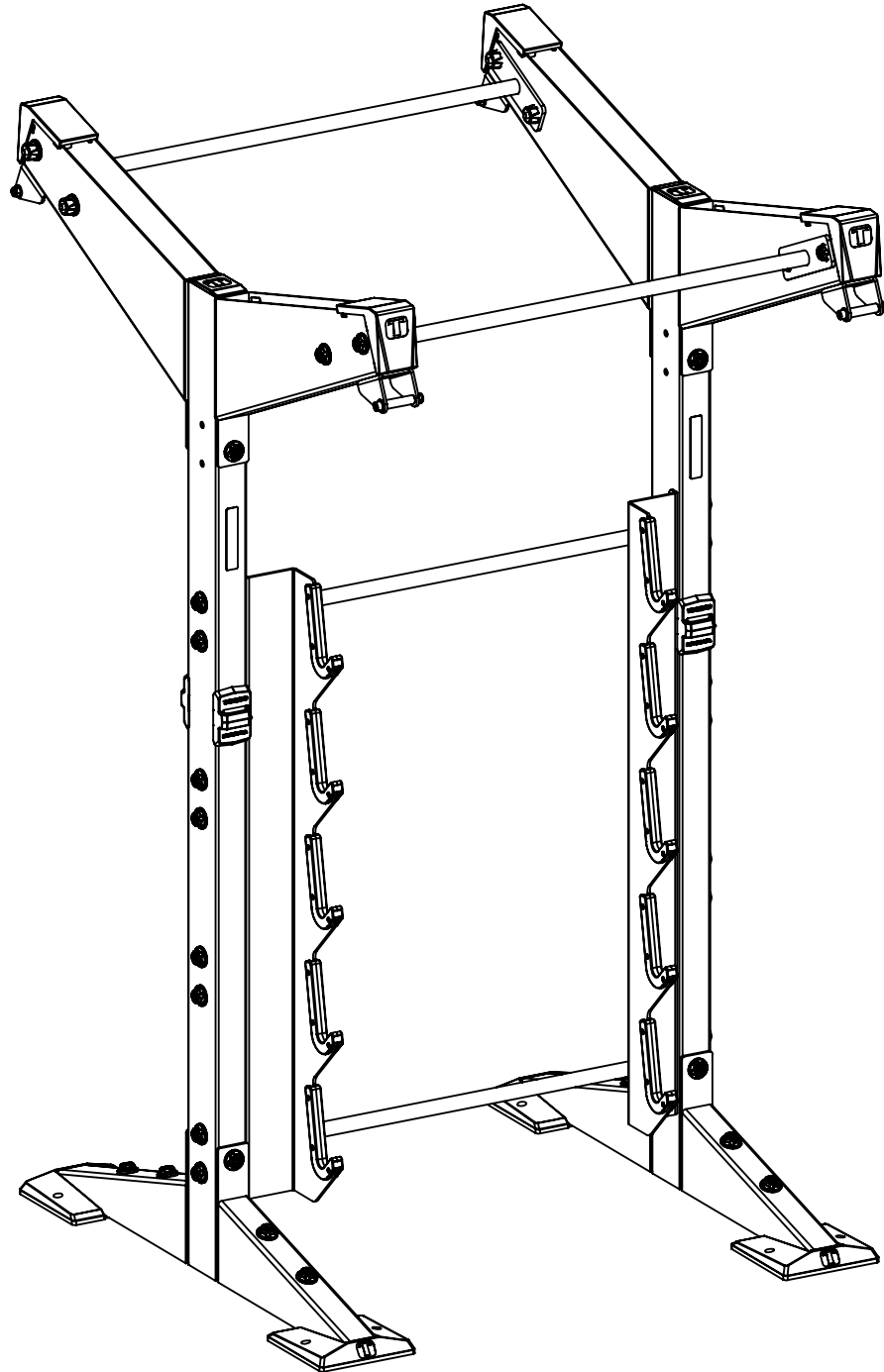

## 4' X 5 BARBELL STORAGE MODULE (WITHOUT CONNECTOR)

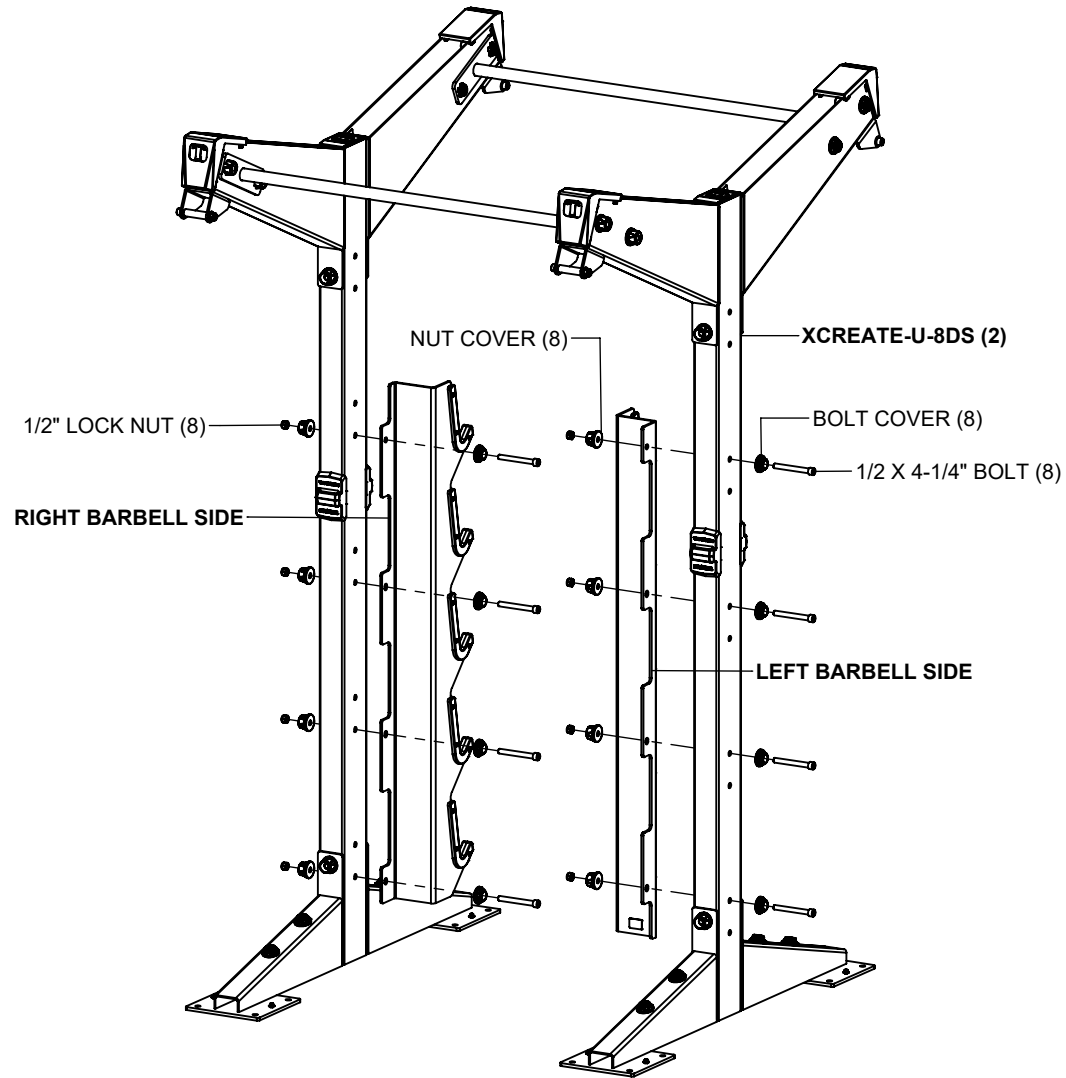

### NOTES:

If more modules will be assembled, do not tighten bolts at this time.  
If this is the only module being assembled, then **SECURELY** tighten all bolts in this step and previous steps.

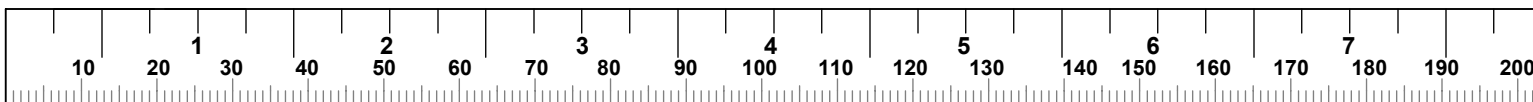

# 4' X 5' BARBELL STORAGE MODULE (WITH CONNECTOR)

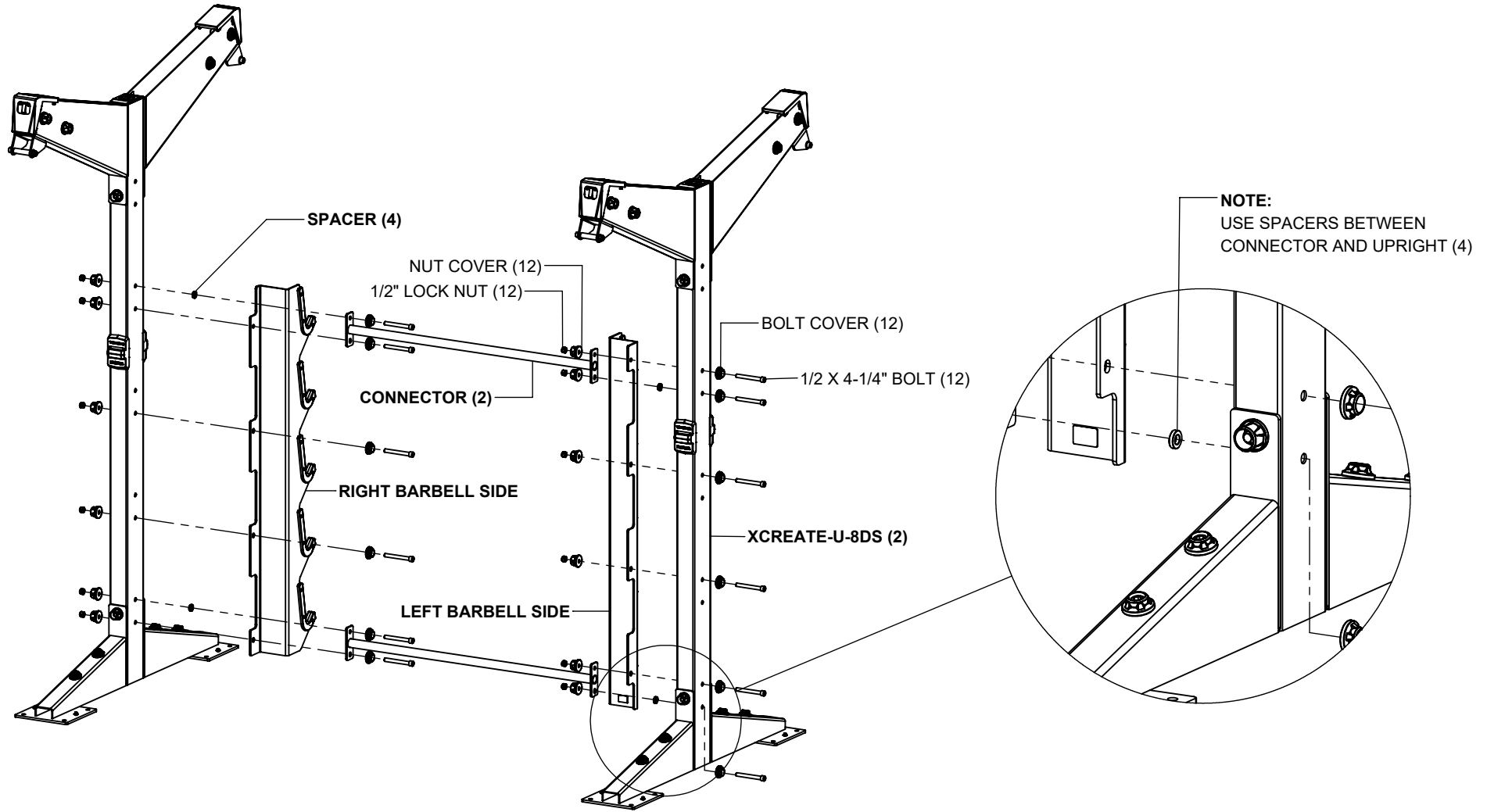

## NOTES:

If more modules will be assembled, do not tighten bolts at this time.  
If this is the only module being assembled, then **SECURELY** tighten all bolts in this step and previous steps.

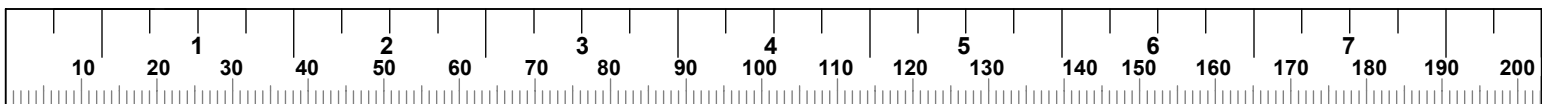

## 4' X 5 BARBELL STORAGE MODULE

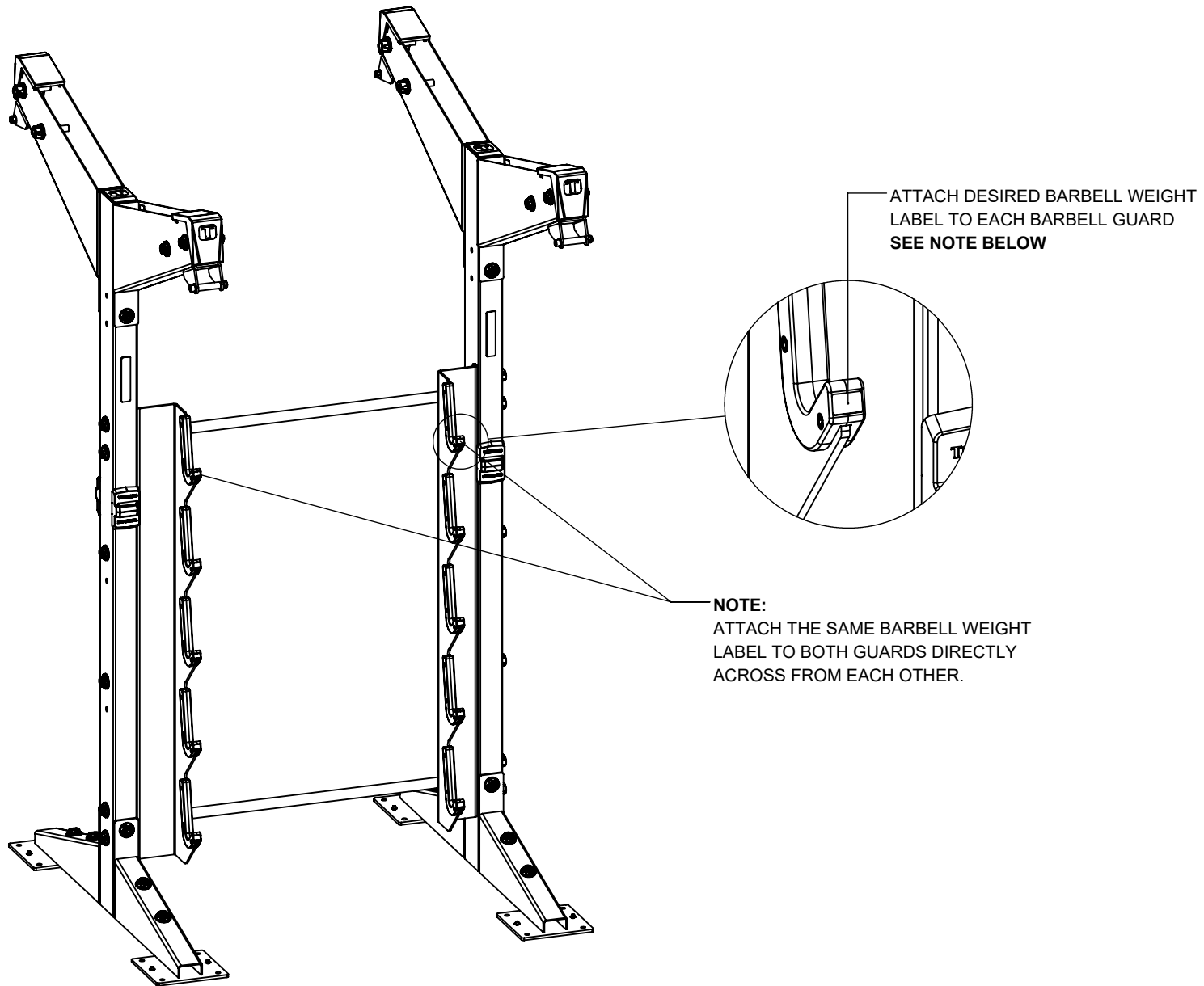

### **NOTE:**

If you are a professional contractor installing this system for a facility, leave these labels and instruction with manager or inquire what label to attach to each barbell guard.

**4' X 10 BARBELL STORAGE MODULE**

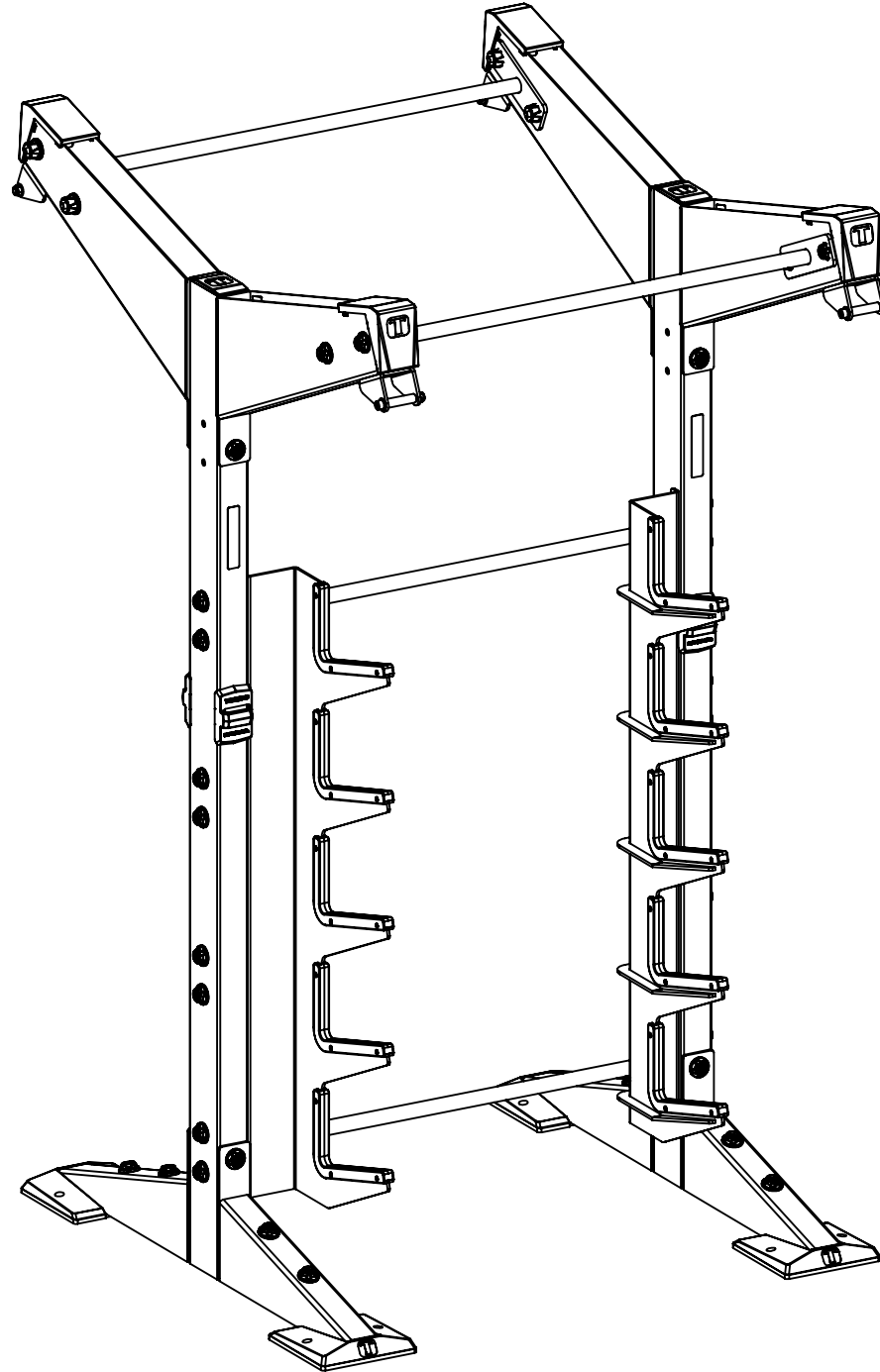

# 4' X 10 BARBELL STORAGE MODULE (WITHOUT CONNECTOR)

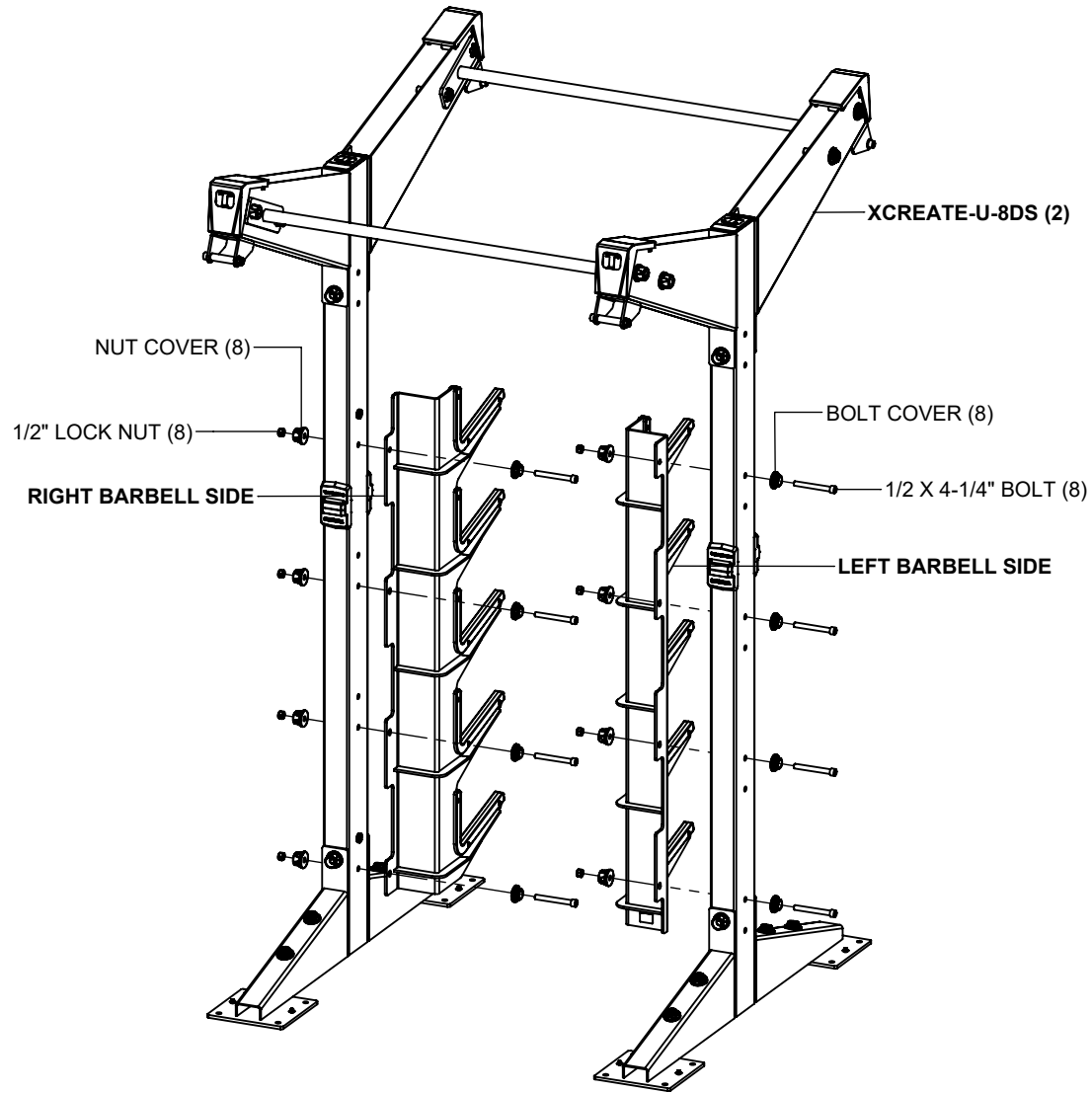

## NOTES:

If more modules will be assembled, do not tighten bolts at this time.  
If this is the only module being assembled, then **SECURELY** tighten all bolts in this step and previous steps.

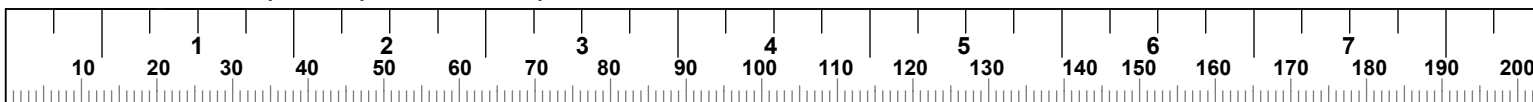

# 4' X 10 BARBELL STORAGE MODULE (WITH CONNECTOR)

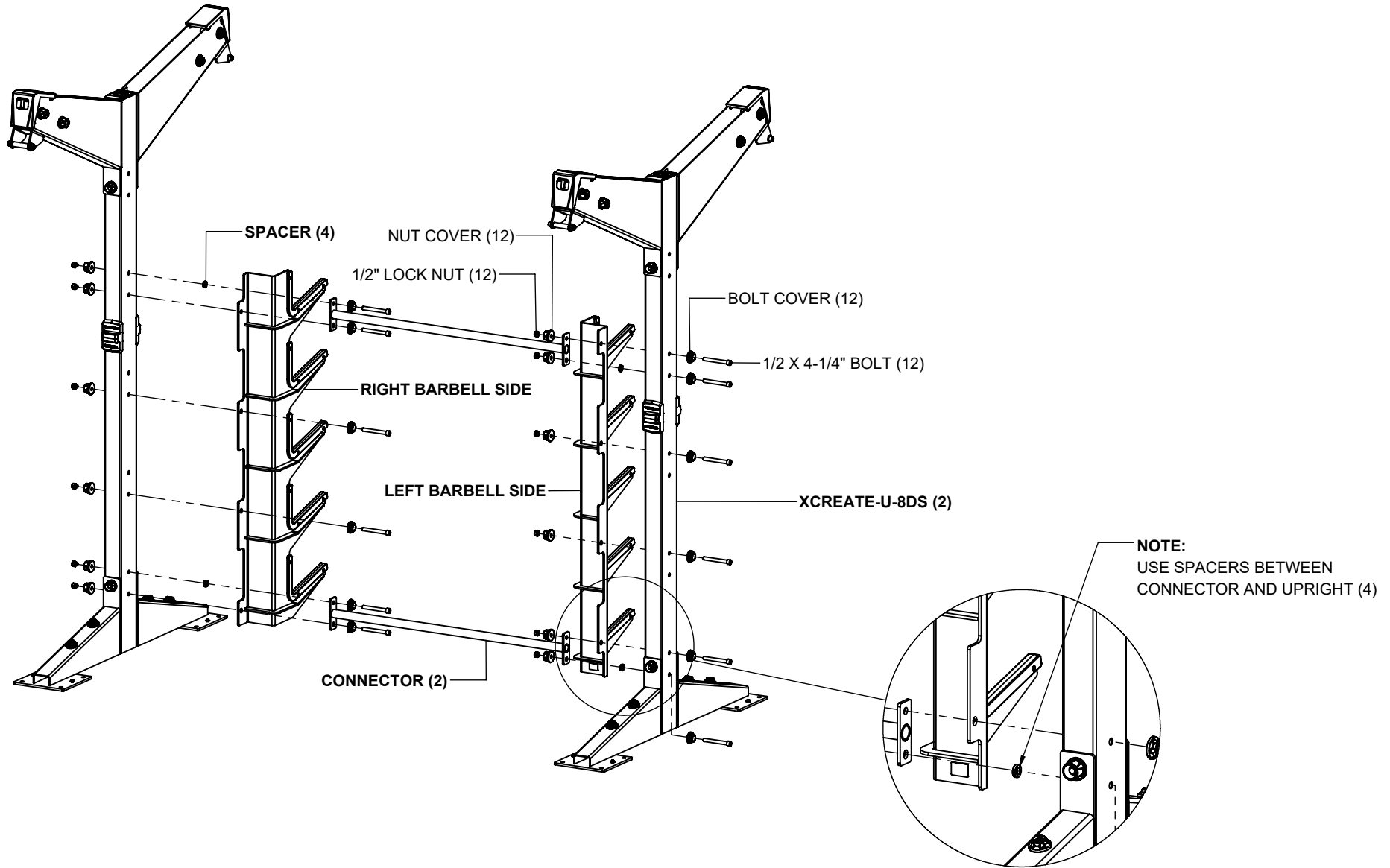

## NOTES:

If more modules will be assembled, do not tighten bolts at this time.  
If this is the only module being assembled, then **SECURELY** tighten all bolts in this step and previous steps.

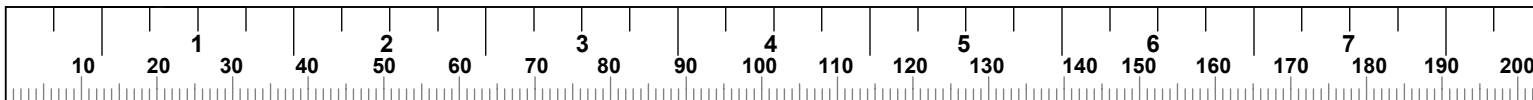

## 4' X 10 BARBELL STORAGE MODULE

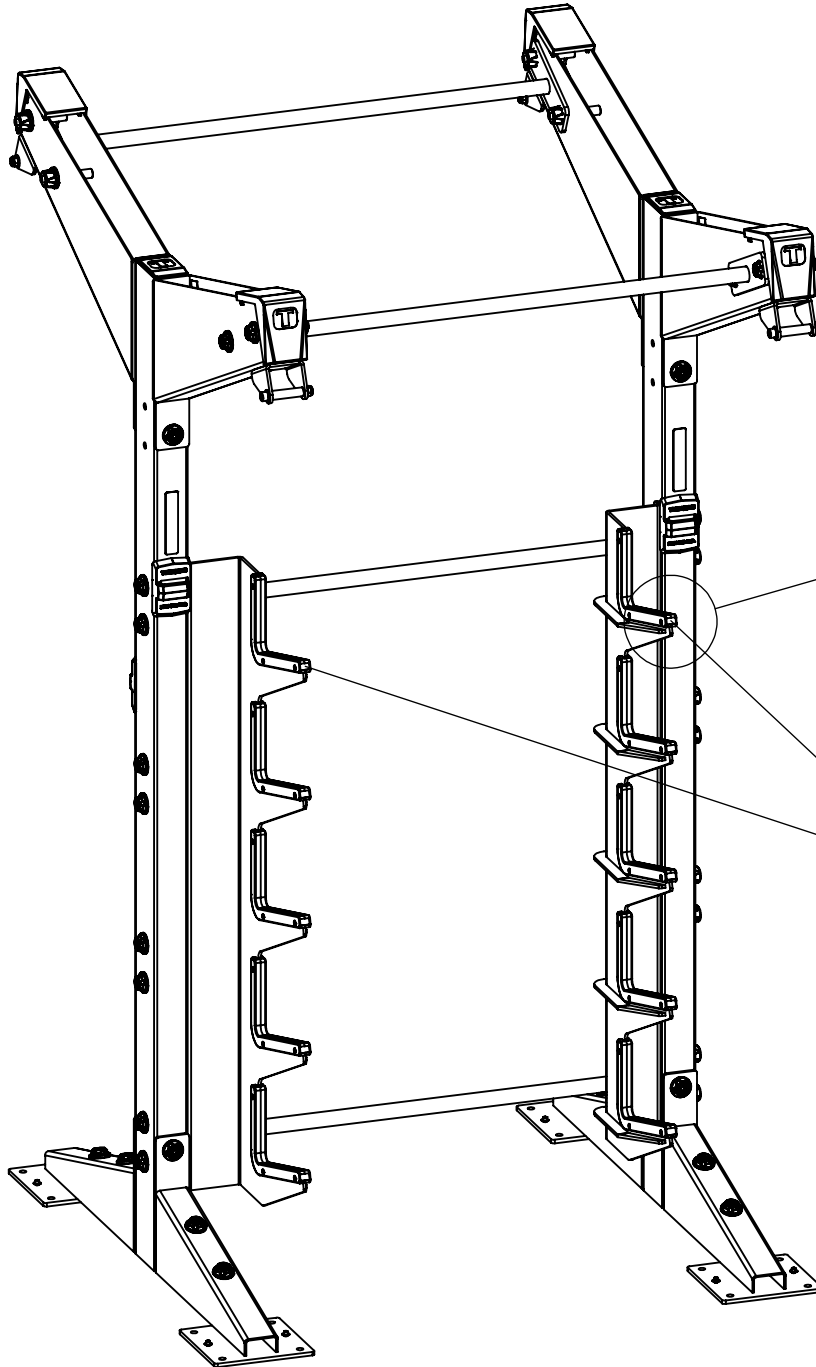

ATTACH DESIRED BARBELL WEIGHT LABEL TO EACH BARBELL GUARD  
SEE NOTE BELOW

**NOTE:**  
ATTACH THE SAME BARBELL WEIGHT LABEL TO BOTH GUARDS DIRECTLY ACROSS FROM EACH OTHER.

**NOTE:**

If you are a professional contractor installing this system for a facility, leave these labels and instruction with manager or inquire what label to attach to each barbell guard.

**4' 2 SIDED X 10 BARBELL STORAGE MODULE**

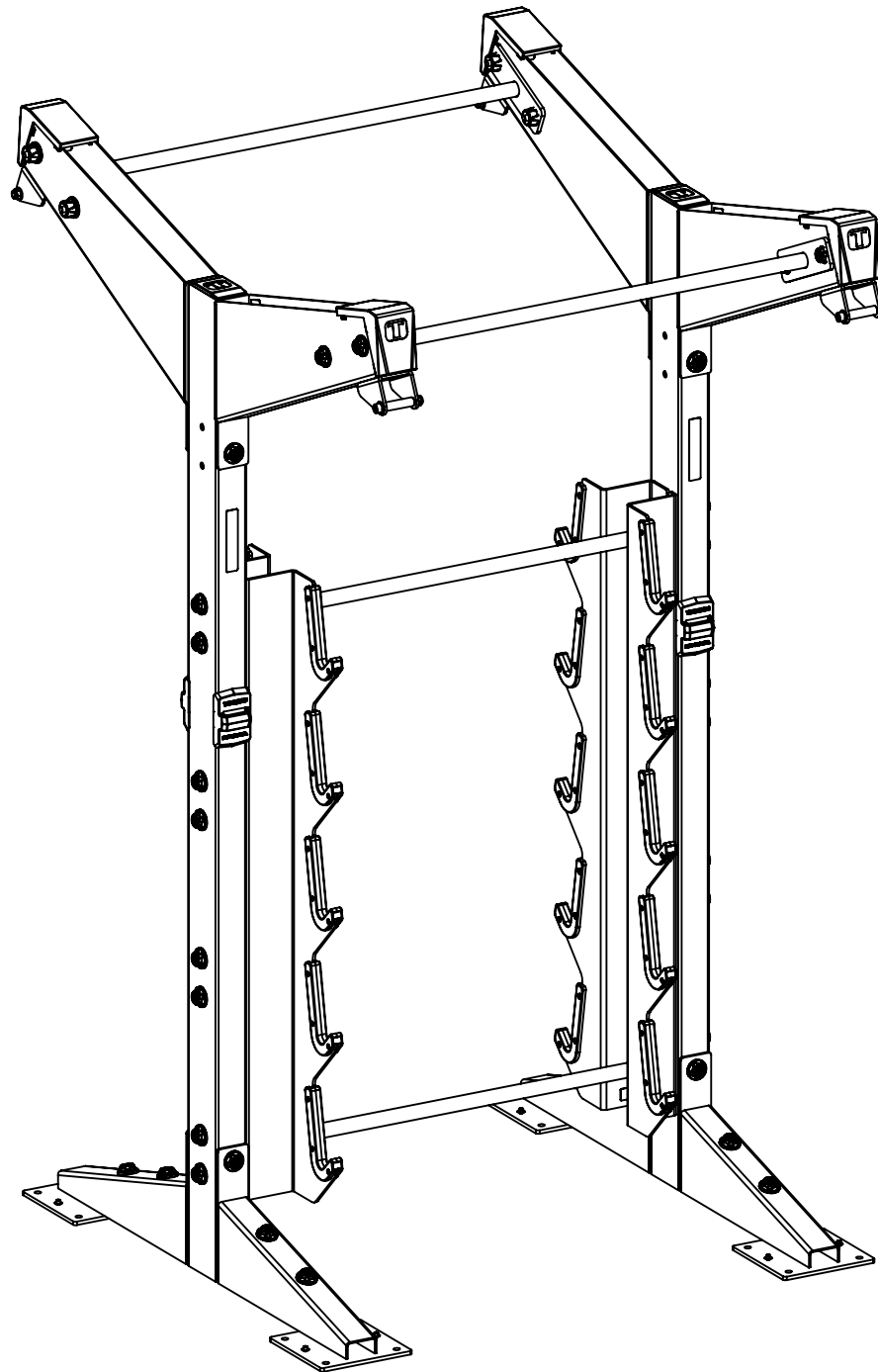

**4' 2 SIDED X 10 BARBELL STORAGE MODULE  
(WITHOUT CONNECTOR)**

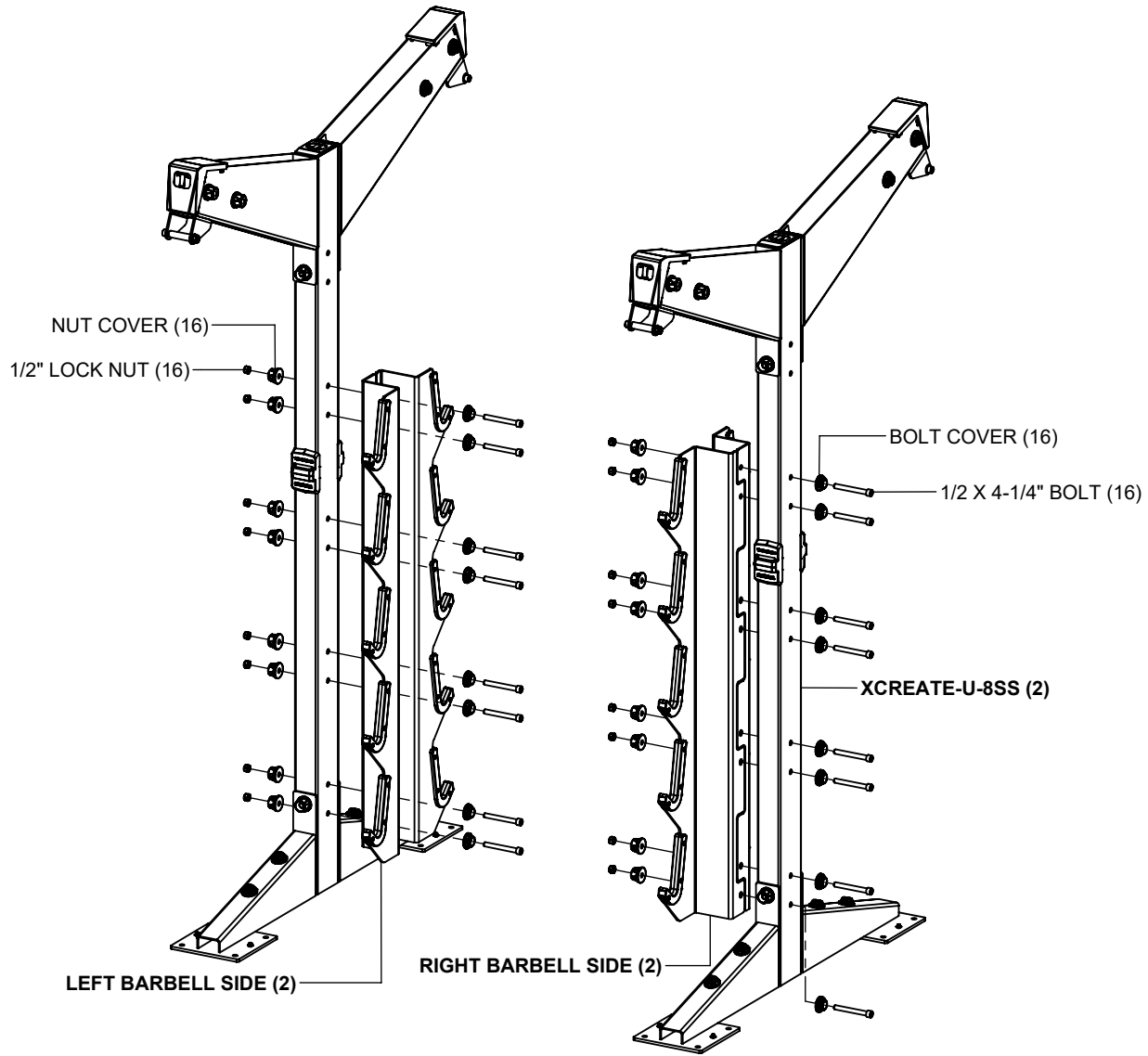

**NOTES:**

If more modules will be assembled, do not tighten bolts at this time.  
If this is the only module being assembled, then **SECURELY** tighten all bolts in this step and previous steps.

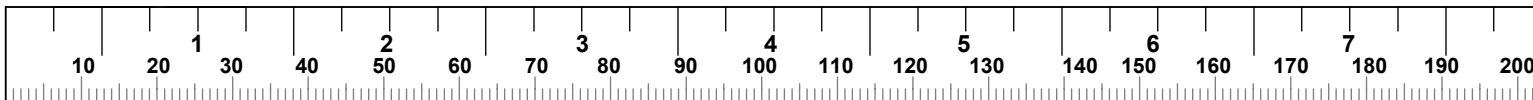

# 4' 2 SIDED X 10 BARBELL STORAGE MODULE (WITH CONNECTOR)

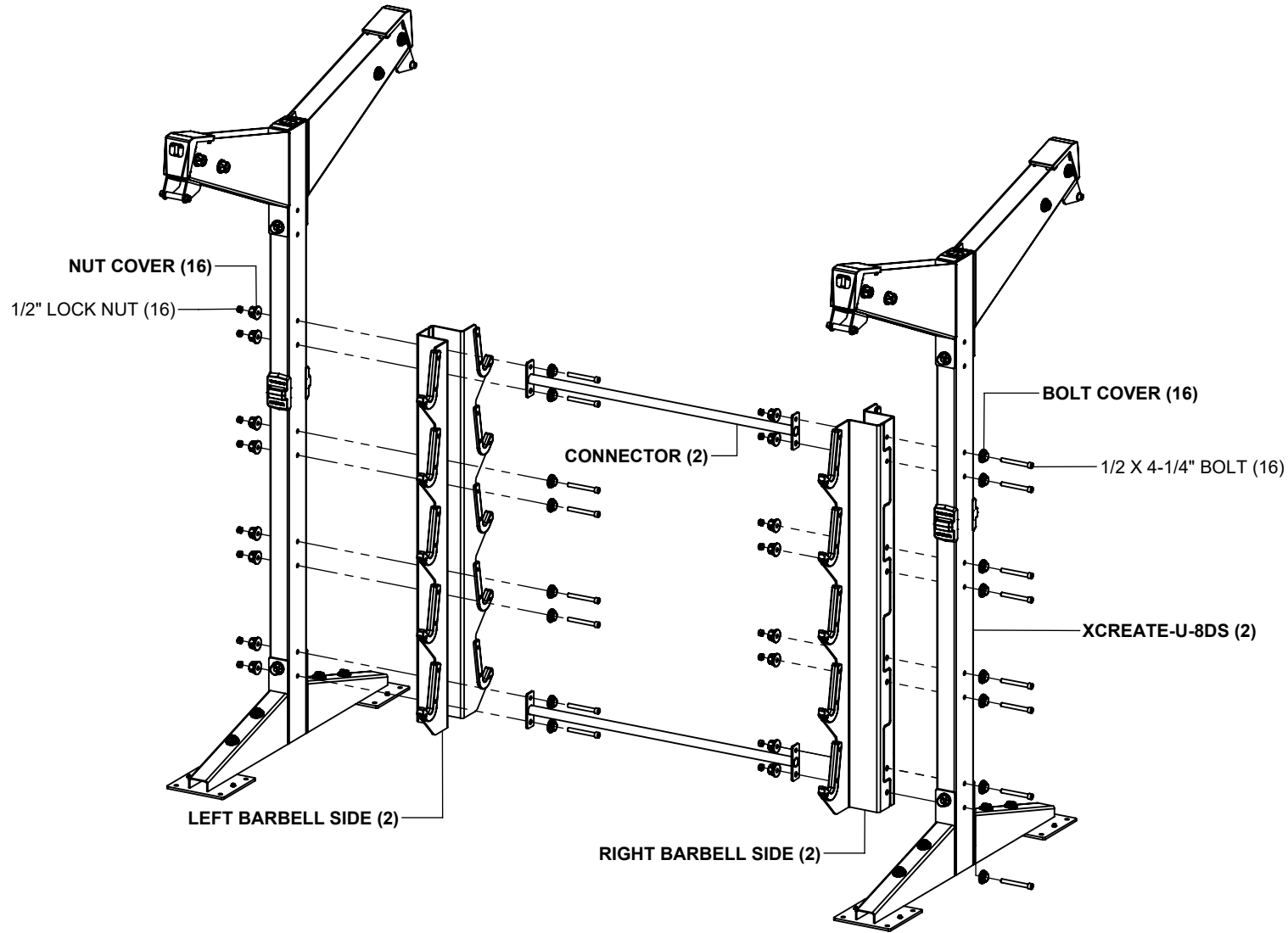

## NOTES:

If more modules will be assembled, do not tighten bolts at this time.  
 If this is the only module being assembled, then **SECURELY** tighten all bolts in this step and previous steps.

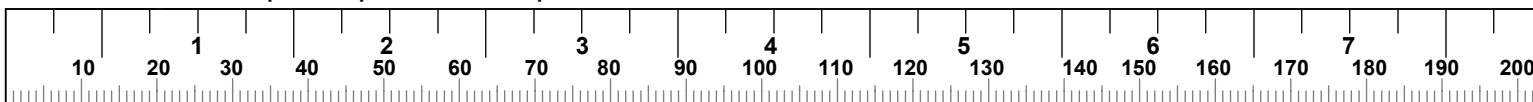

## 4' 2 SIDED X 10 BARBELL STORAGE MODULE

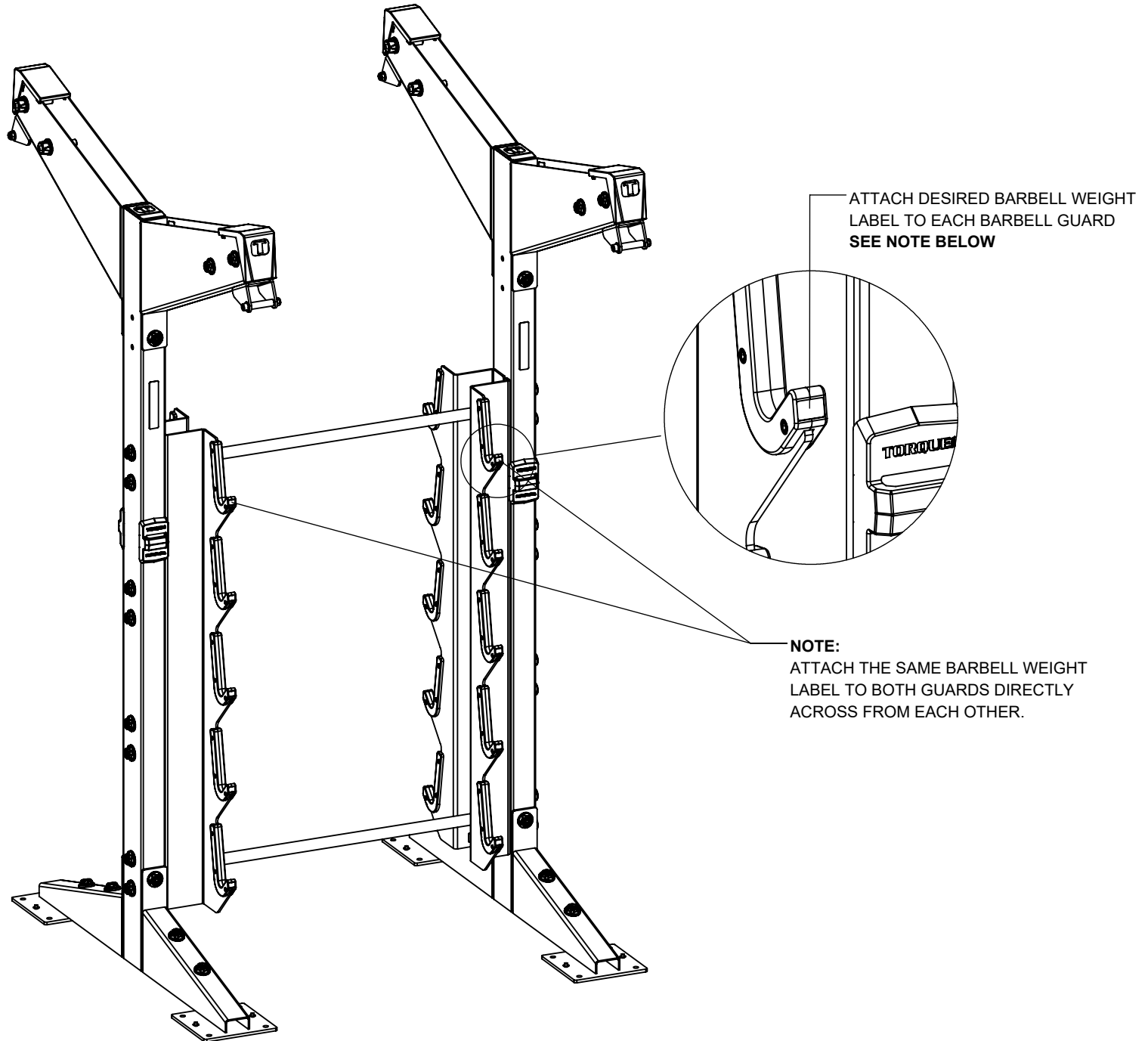

### **NOTE:**

If you are a professional contractor installing this system for a facility, leave these labels and instruction with manager or inquire what label to attach to each barbell guard.

**4' 2 SIDED X 20 BARBELL STORAGE MODULE**

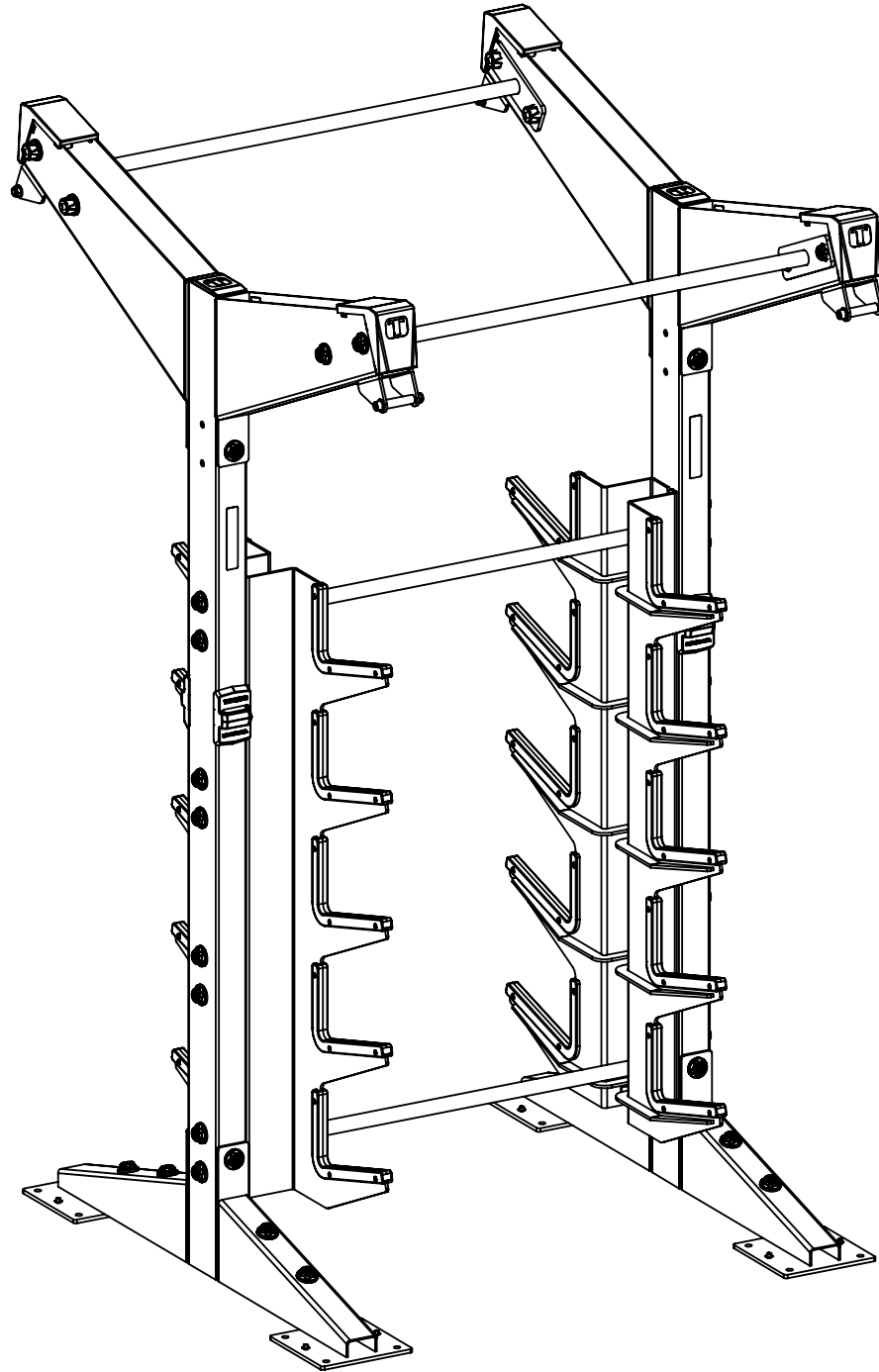

**4' 2 SIDED X 20 BARBELL STORAGE MODULE  
(WITHOUT CONNECTOR)**

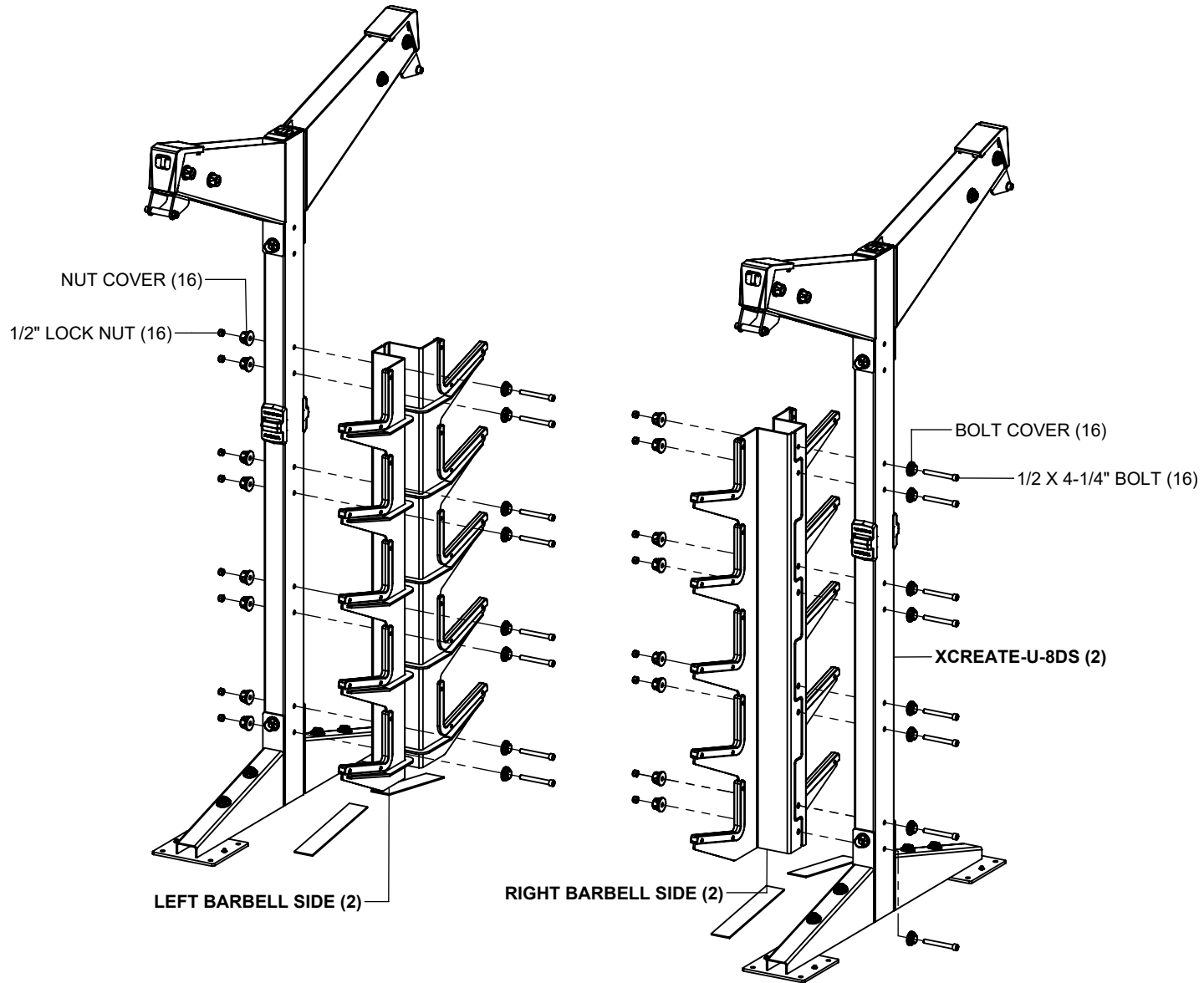

**NOTES:**

If more modules will be assembled, do not tighten bolts at this time.  
If this is the only module being assembled, then **SECURELY** tighten all bolts in this step and previous steps.

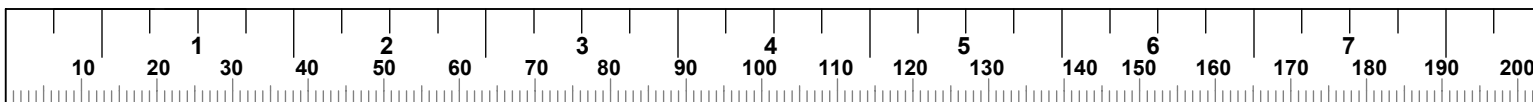

**4' 2 SIDED X 20 BARBELL STORAGE MODULE  
(WITH CONNECTOR)**

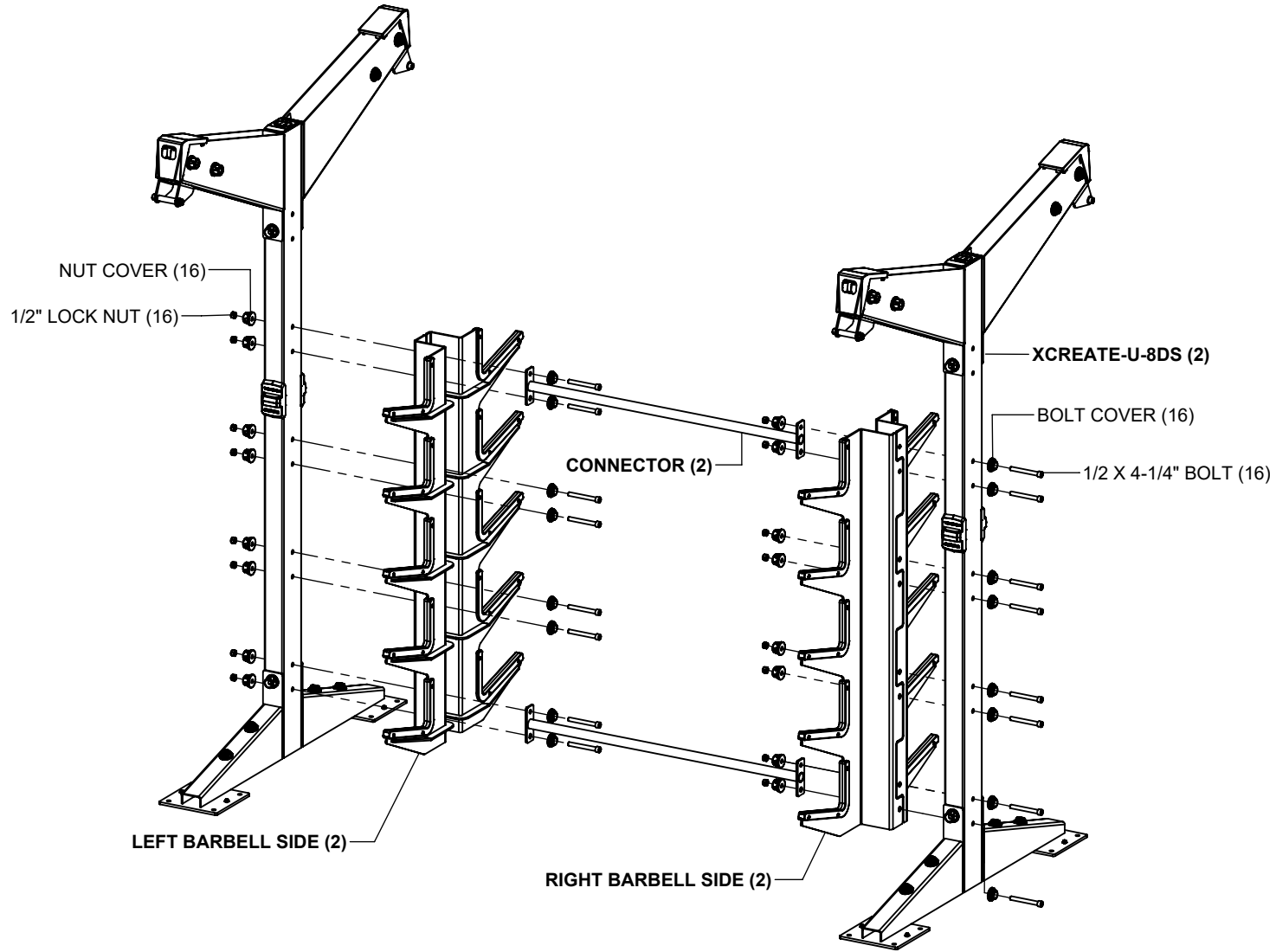

**NOTES:**

If more modules will be assembled, do not tighten bolts at this time.  
If this is the only module being assembled, then **SECURELY** tighten all bolts in this step and previous steps.

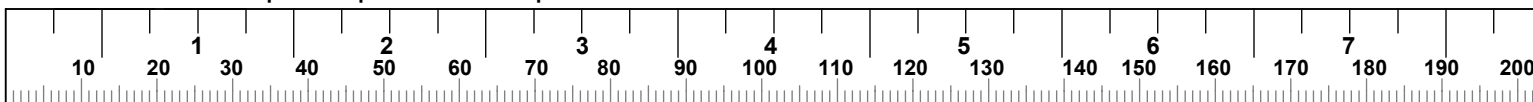

## 4' 2 SIDED X 10 BARBELL STORAGE MODULE

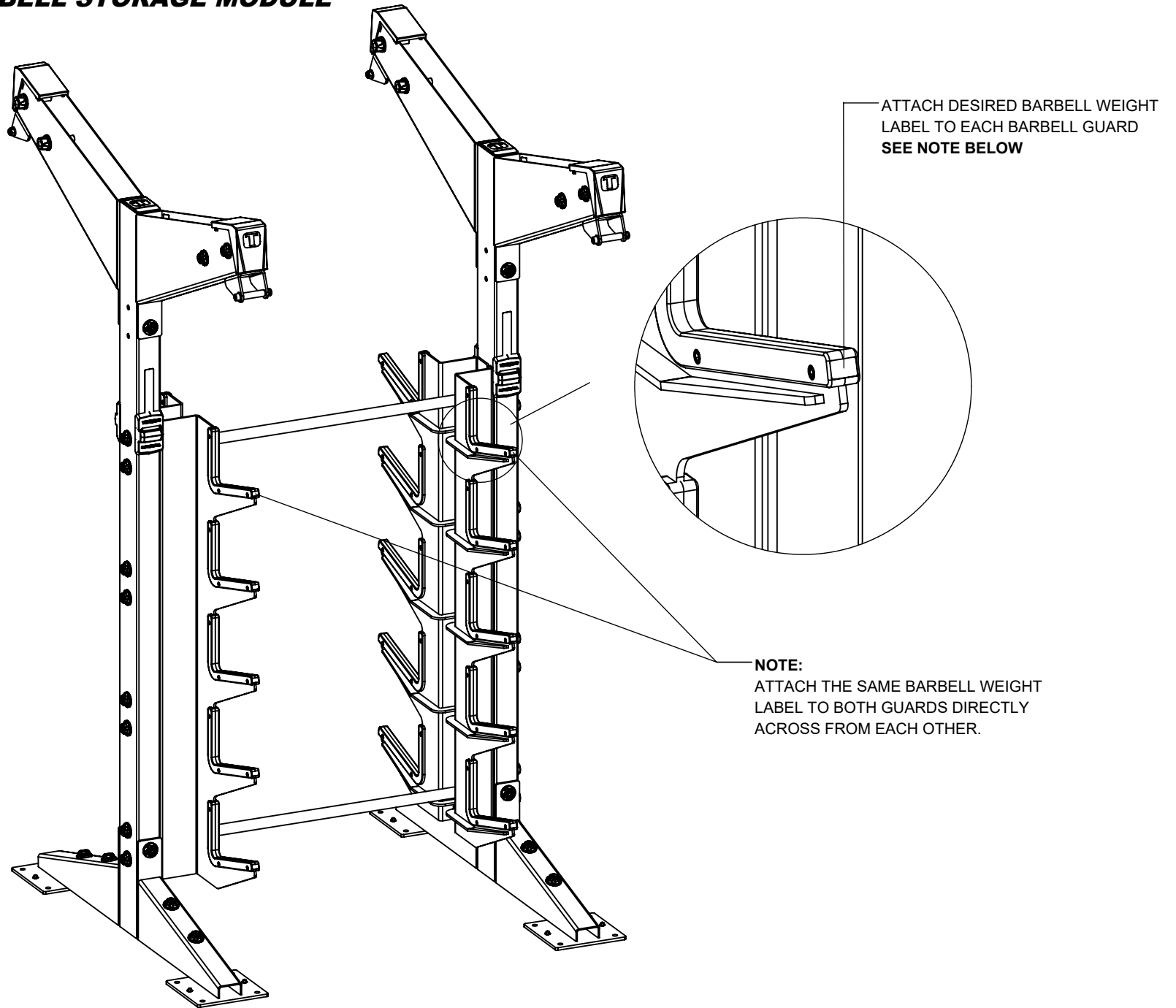

**NOTE:**

If you are a professional contractor installing this system for a facility, leave these labels and instruction with manager or inquire what label to attach to each barbell guard.

**4' MONITOR MOUNT & STORAGE MODULE**

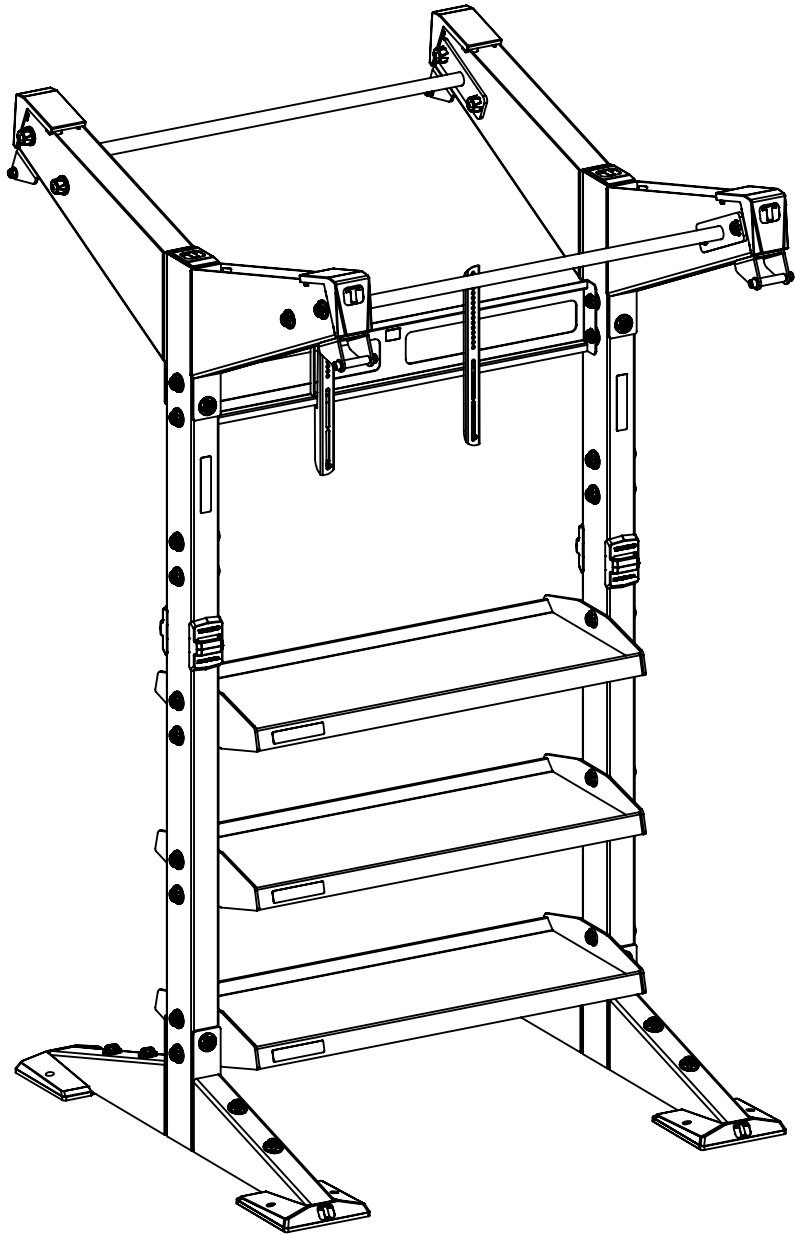

**STANDARD CONFIGURATION**

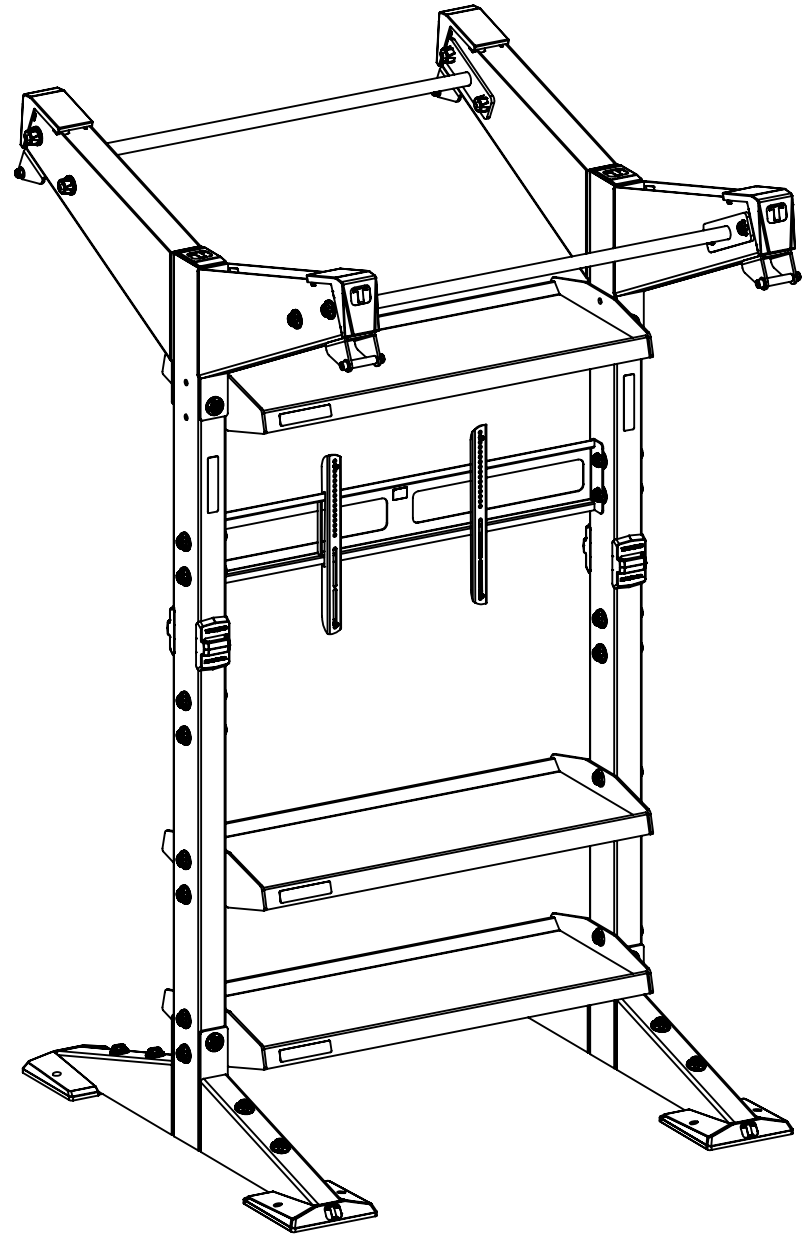

**OPTIONAL CONFIGURATION**

# 4' MONITOR MOUNT & STORAGE MODULE

## STEP 1A

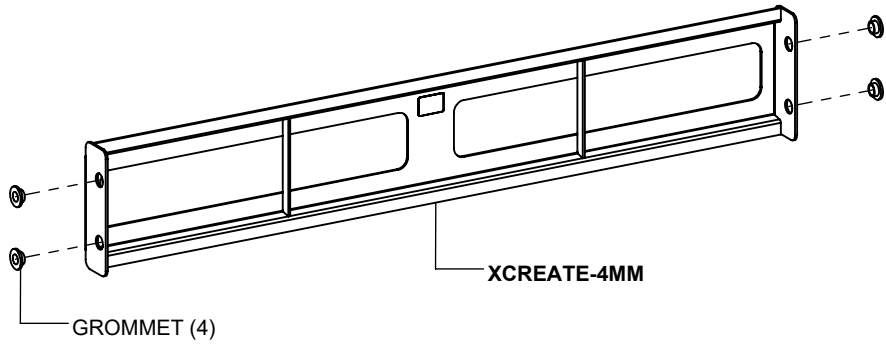

## STEP 1B

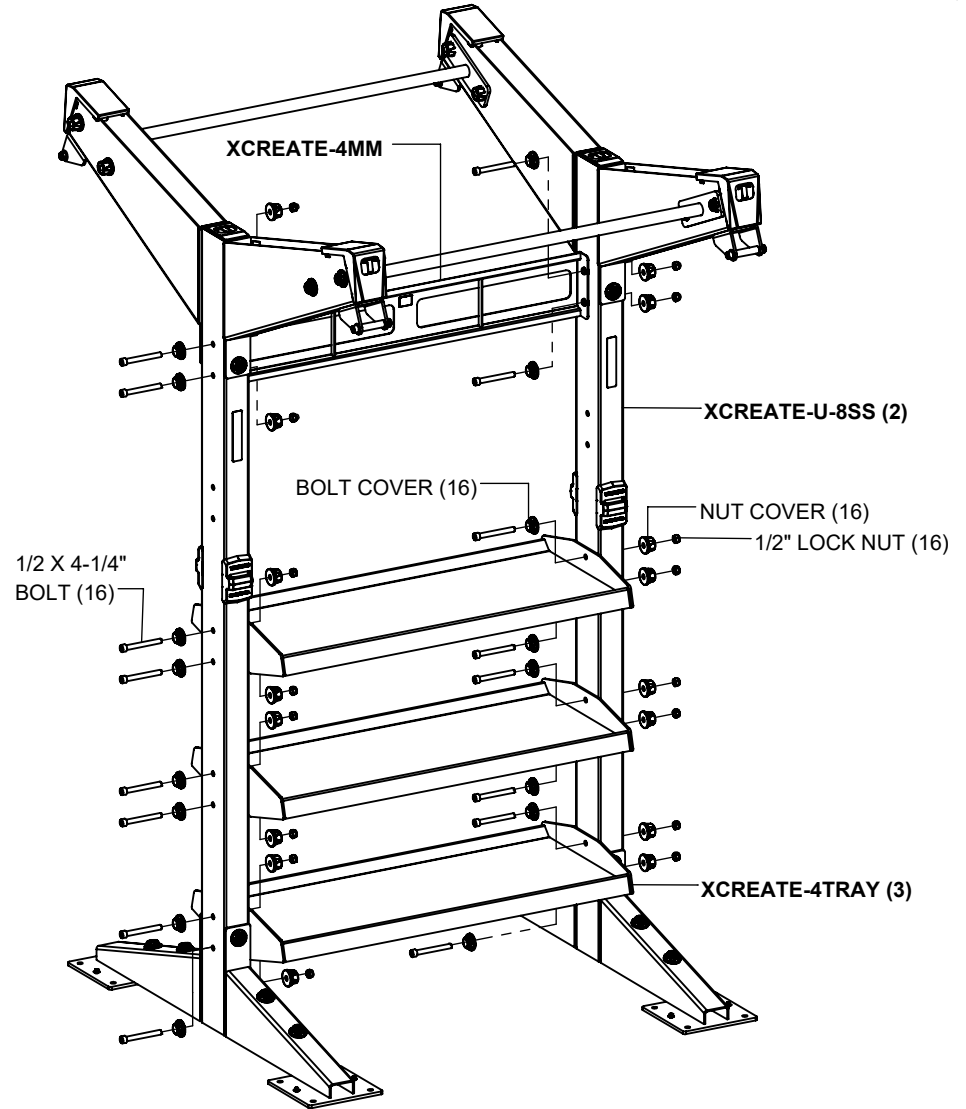

### NOTES:

If more modules will be assembled, do not tighten bolts at this time. If this is the only module being assembled, then **SECURELY** tighten all bolts in this step and previous steps.

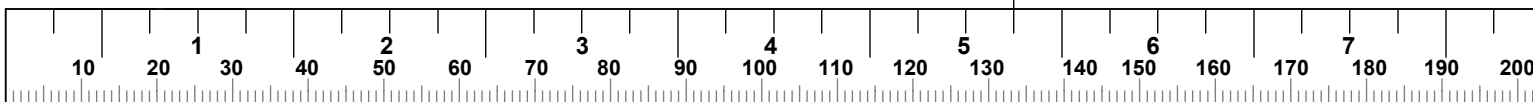

# 4' MONITOR MOUNT & STORAGE MODULE

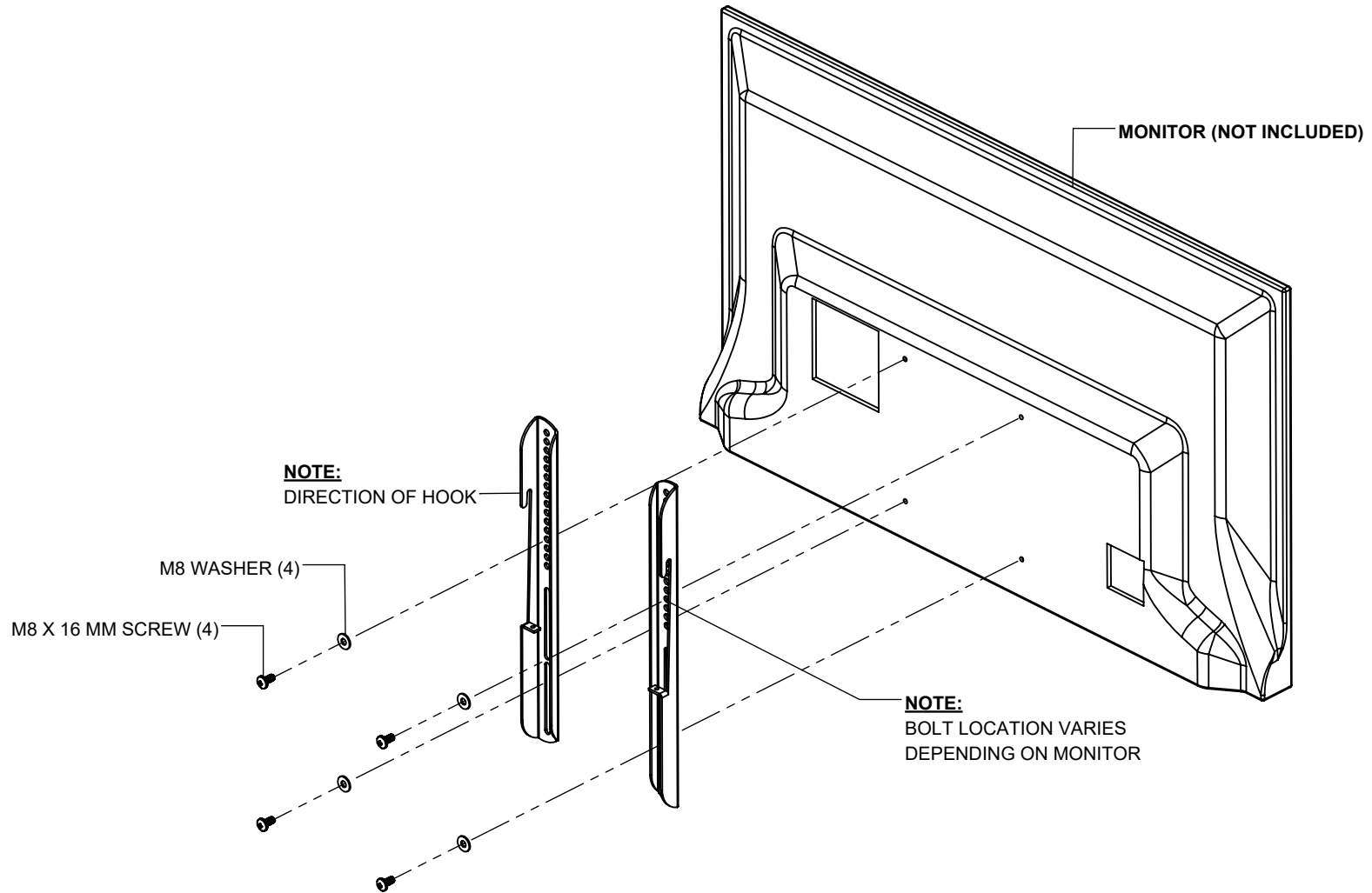

## **NOTE:**

**SECURELY** tighten all connections in this step.

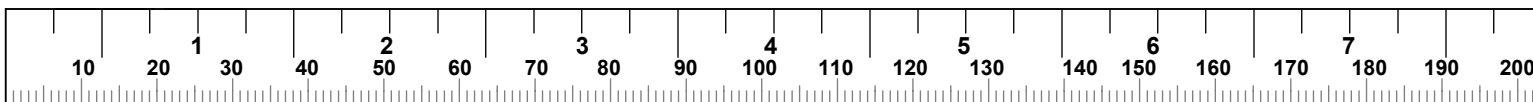

# 4' MONITOR MOUNT & STORAGE MODULE

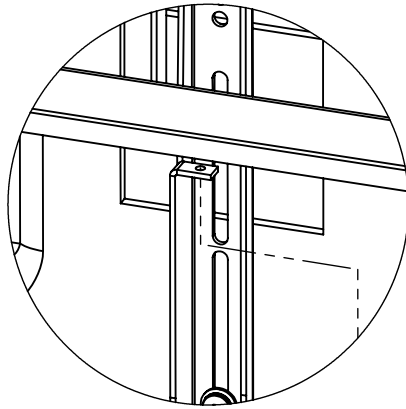

**NOTE:**  
CENTER MONITOR BEFORE TIGHTENING

M6 x 35 MM BOLT(2)

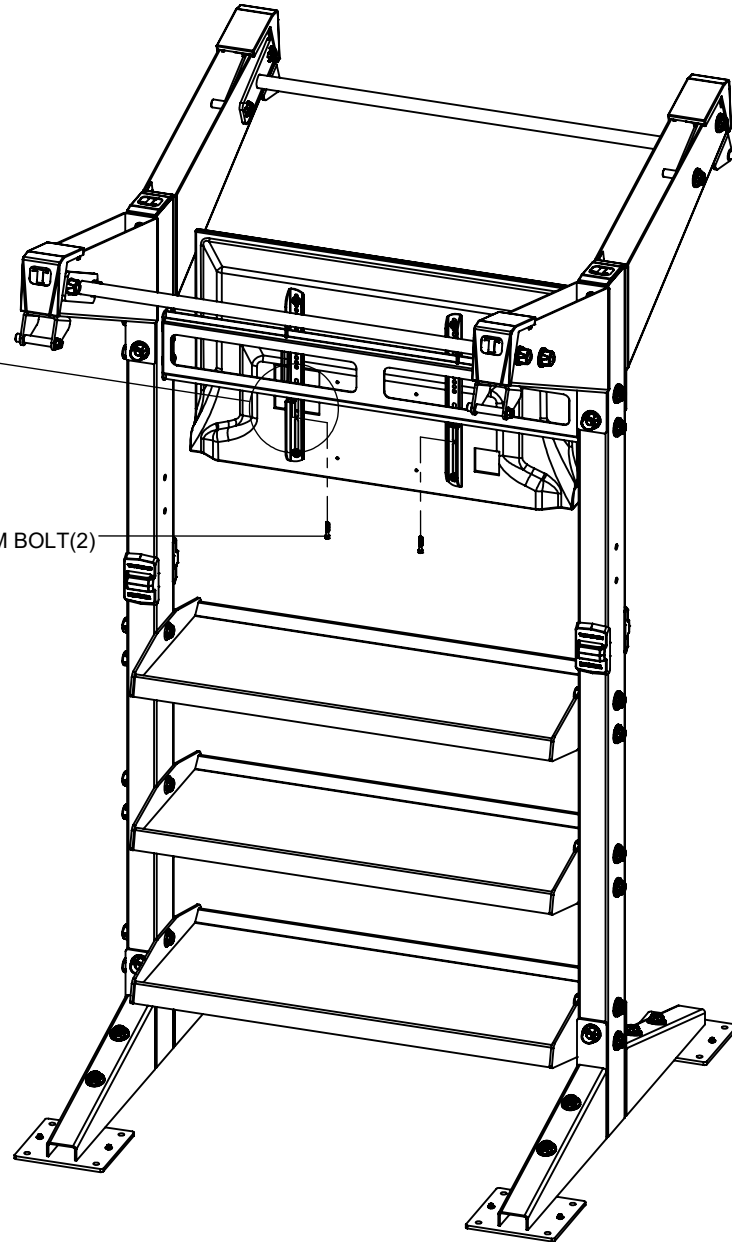

**NOTE:**

**SECURELY** tighten all connections in this step.

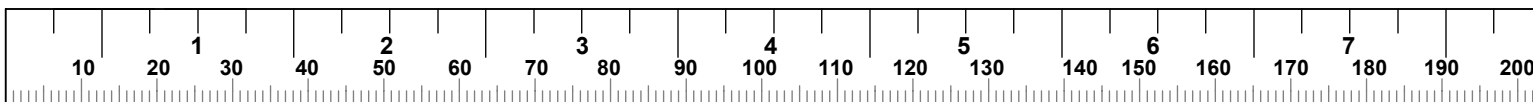

**4' CUSTOM SIGN AND HANGING STORAGE MODULE**

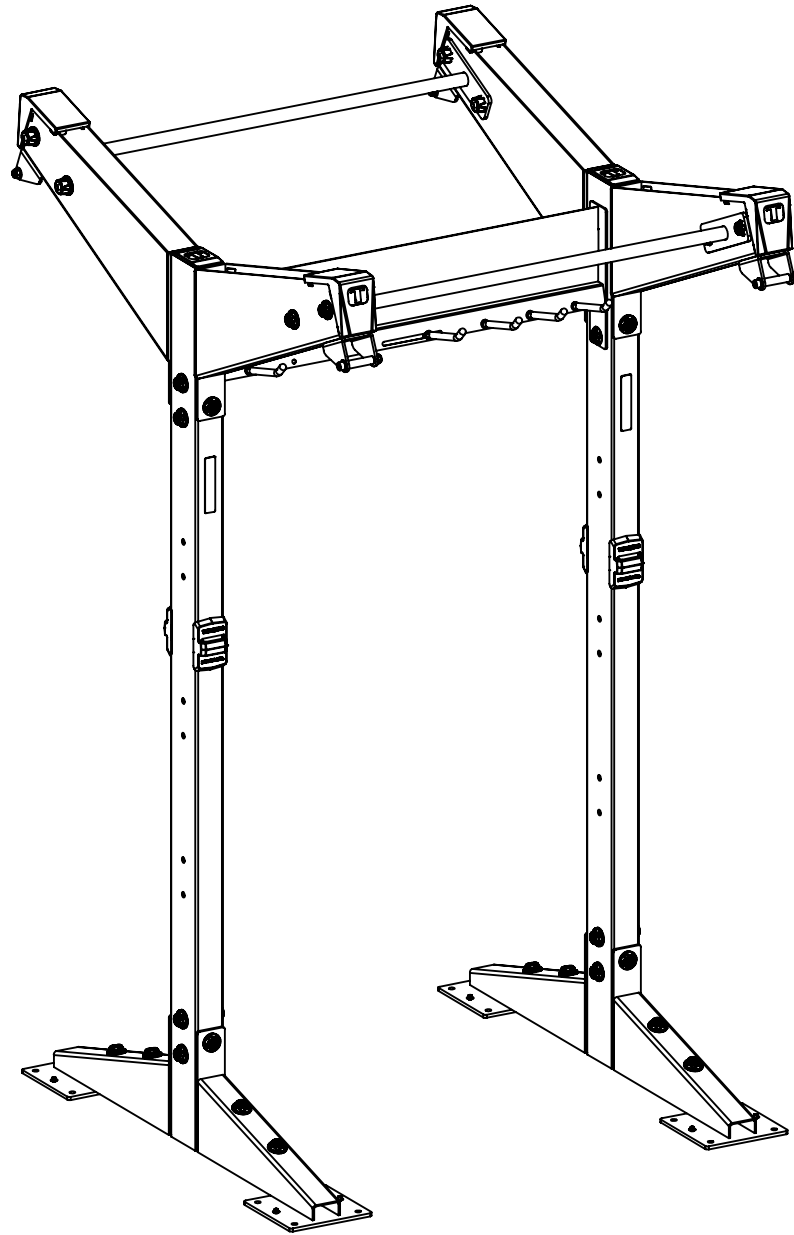

## 4' CUSTOM SIGN AND HANGING STORAGE MODULE

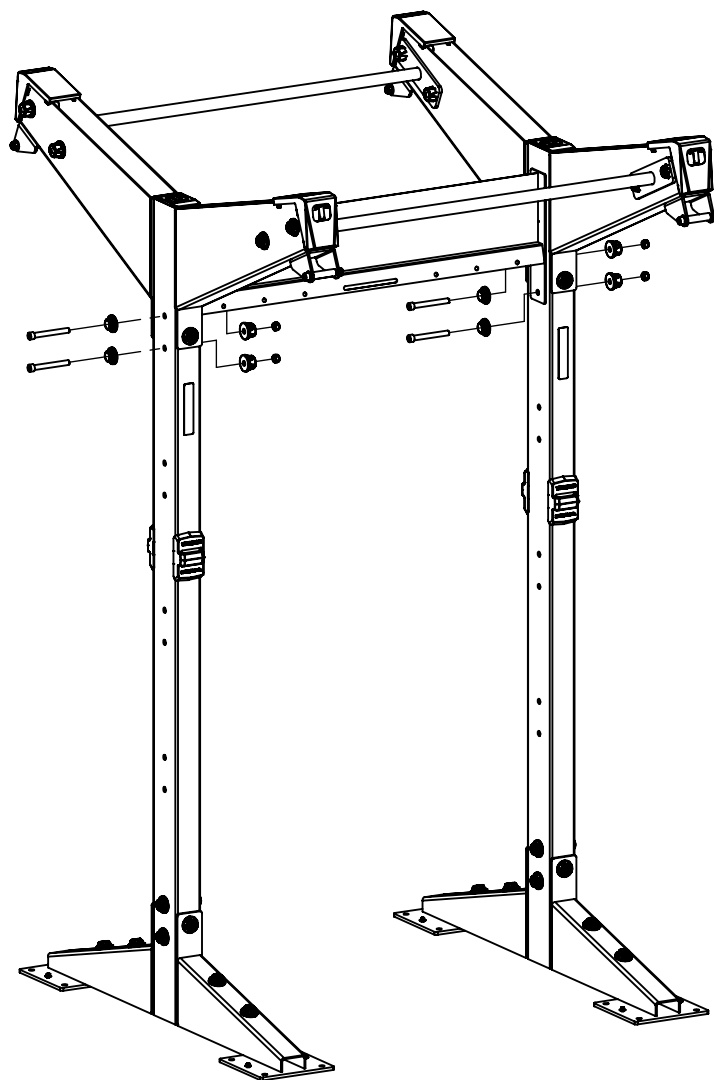

### NOTES:

If more modules will be assembled, do not tighten bolts at this time. If this is the only module being assembled, then **SECURELY** tighten all bolts in this step and previous steps.

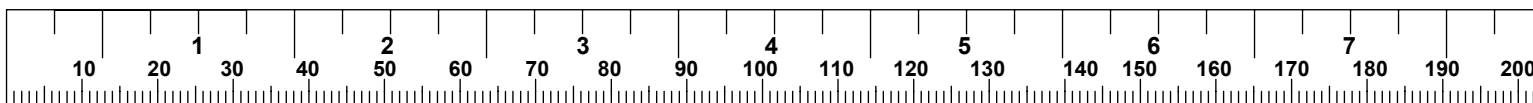

**2.5' BALL AND HANGING STORAGE MODULE**

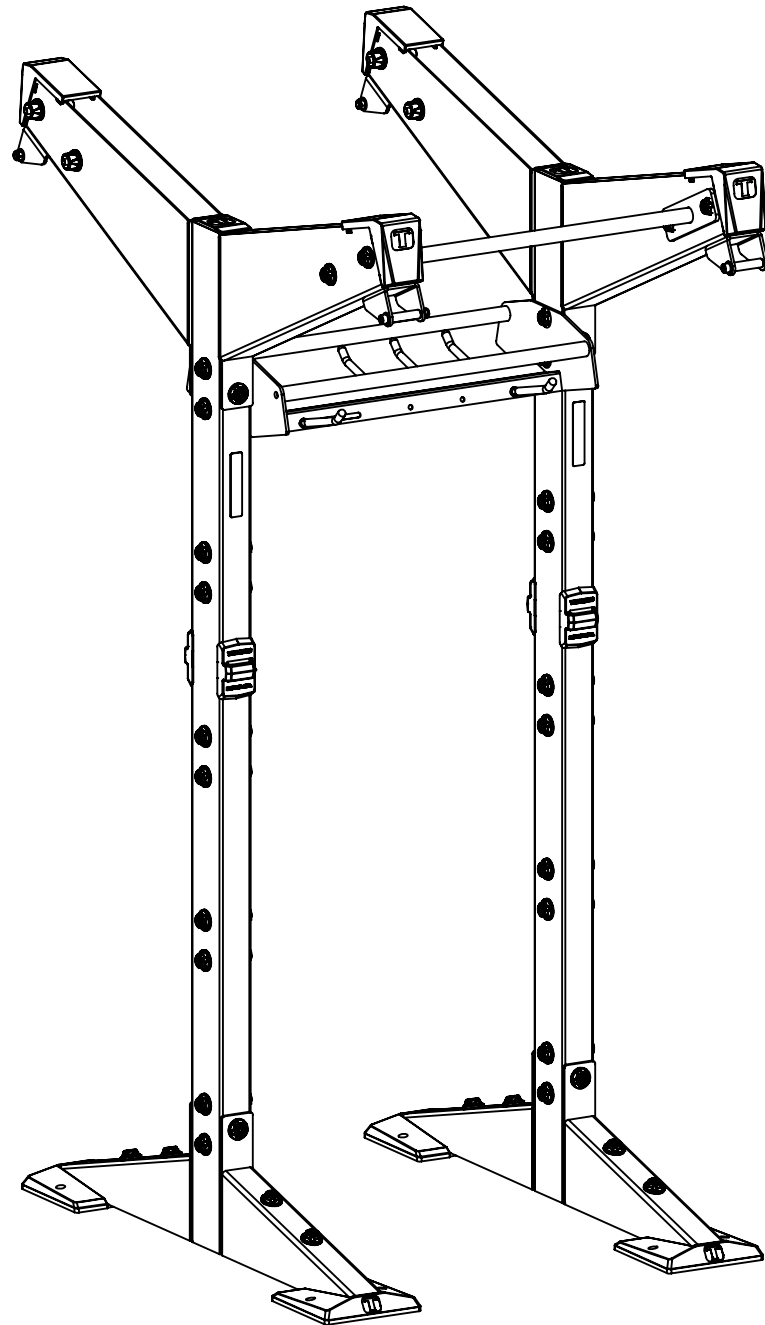

## 2.5' BALL AND HANGING STORAGE MODULE

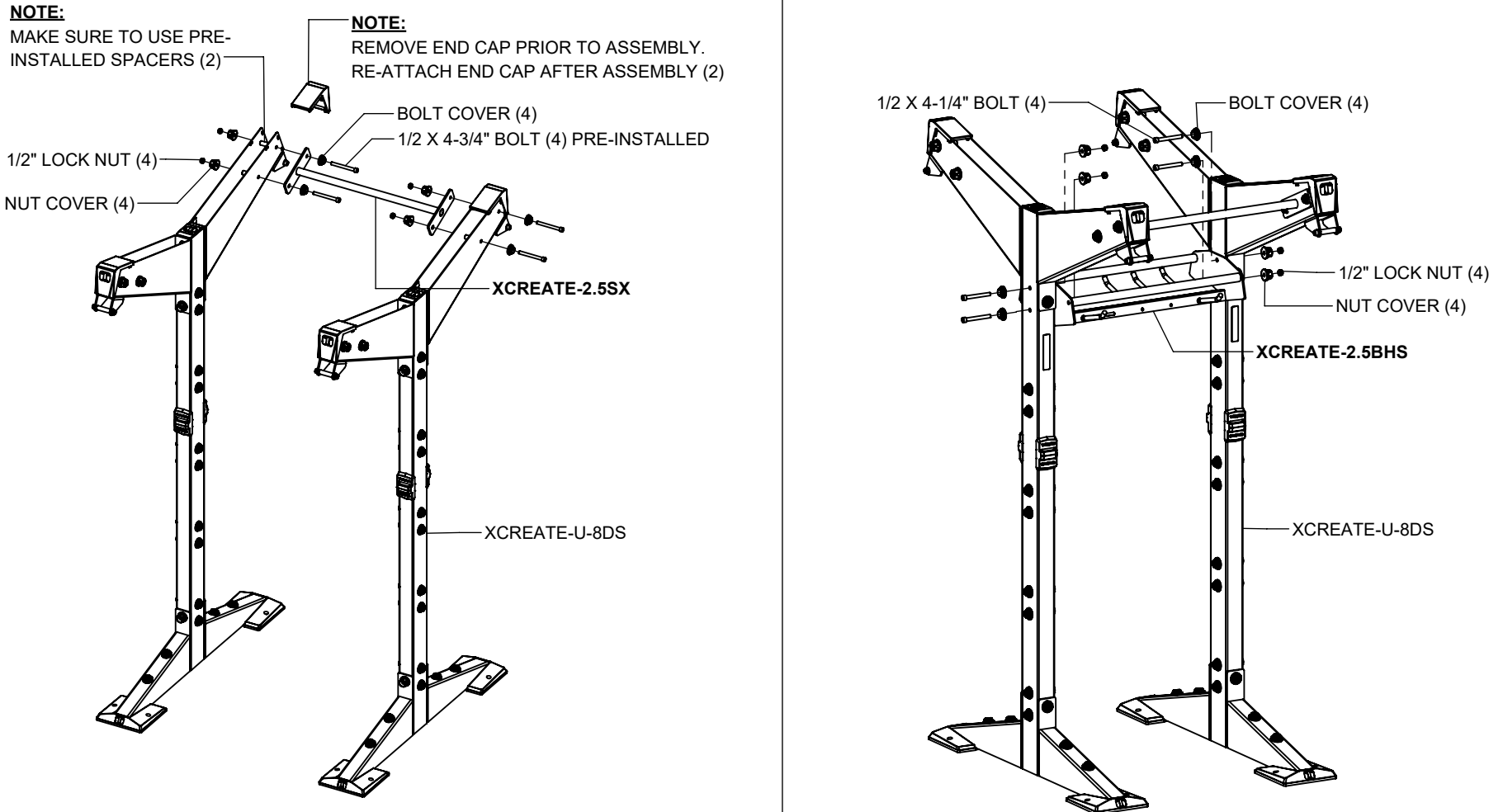

### **NOTES:**

If more modules will be assembled, do not tighten bolts at this time.  
If this is the only module being assembled, then **SECURELY** tighten all bolts in this step and previous steps.

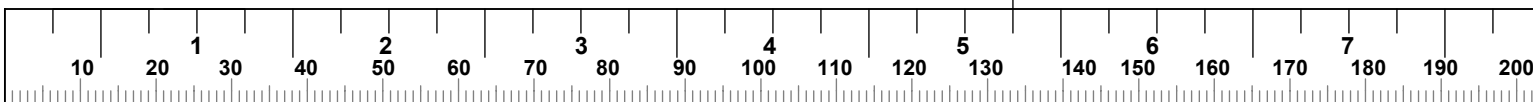

**6' RECTANGULAR CROSS MODULE**

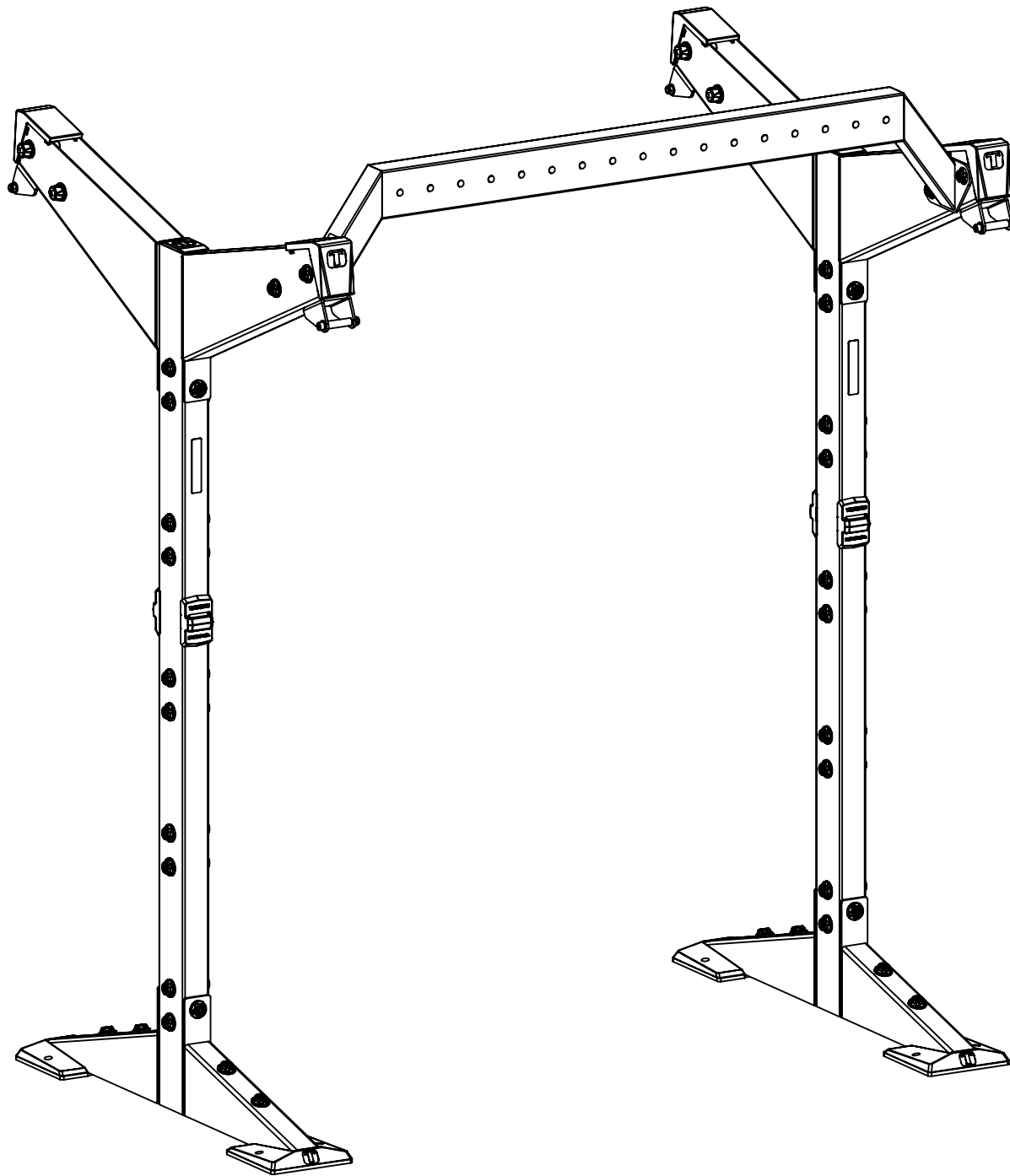

# 6' RECTANGULAR CROSS MODULE

**NOTE:**

REMOVE END CAP PRIOR TO ASSEMBLY.  
RE-ATTACH END CAP AFTER ASSEMBLY (2)

**NOTE:**

MAKE SURE TO USE PRE-INSTALLED SPACERS (2)

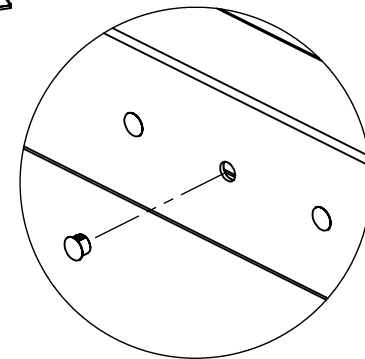
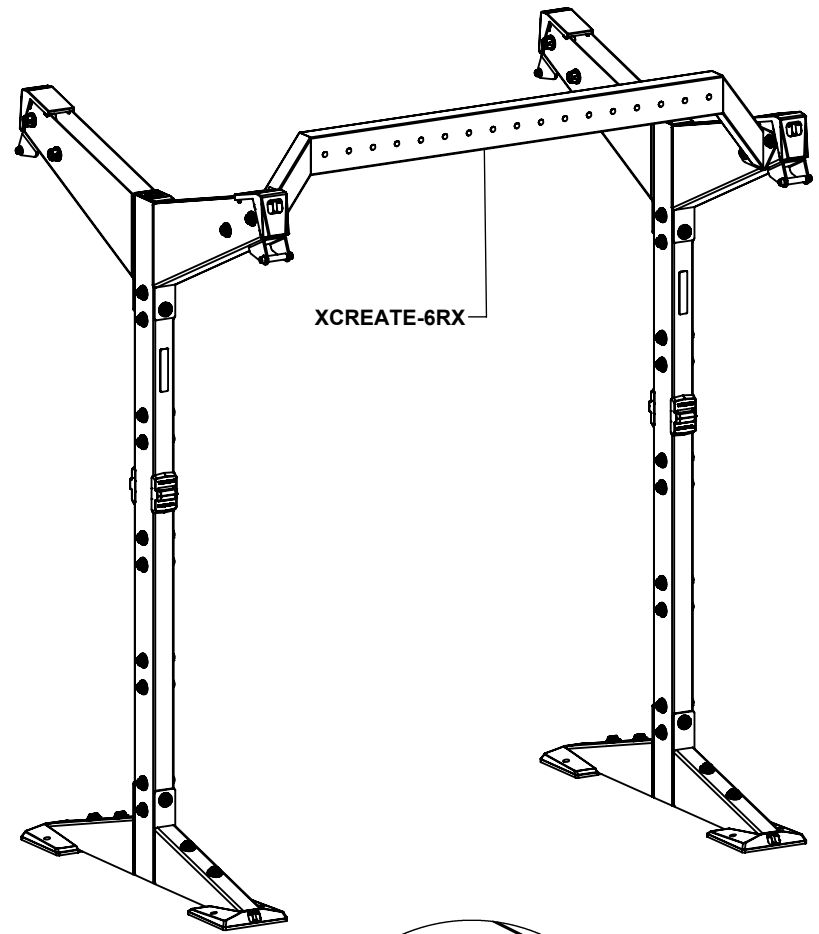
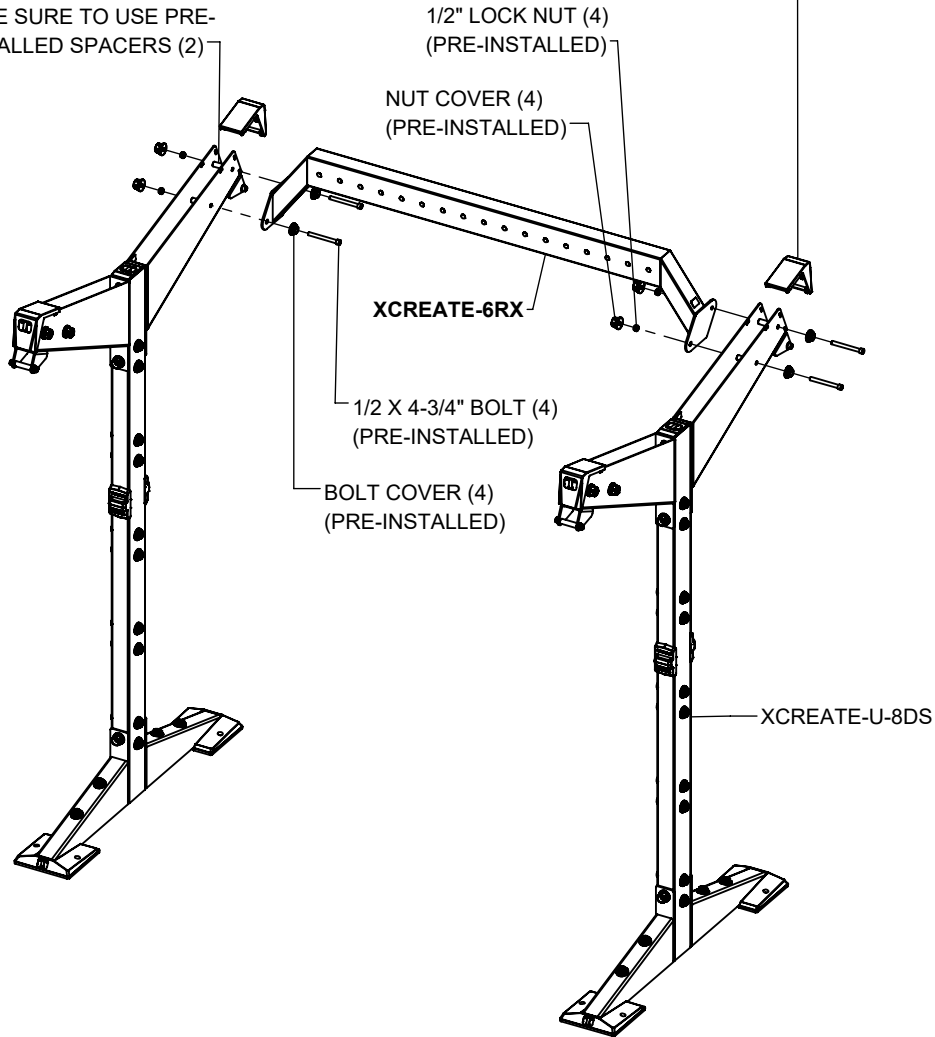

**NOTE:**

AFTER ALL ATTACHMENTS HAVE BEEN ASSEMBLED (SEE ATTACHMENT SECTION), COVER ALL EMPTY HOLES WITH THE COVER CAPS PROVIDED.

**NOTES:**

If more modules will be assembled, do not tighten bolts at this time. If this is the only module being assembled, then **SECURELY** tighten all bolts in this step and previous steps.

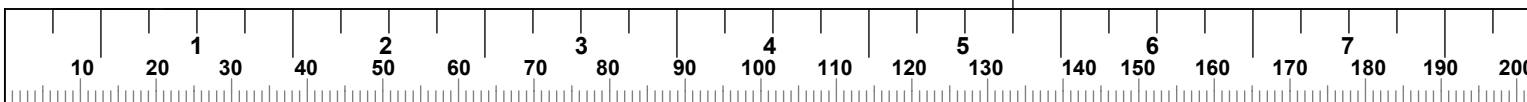

**4' HEAVY BAG MODULE**

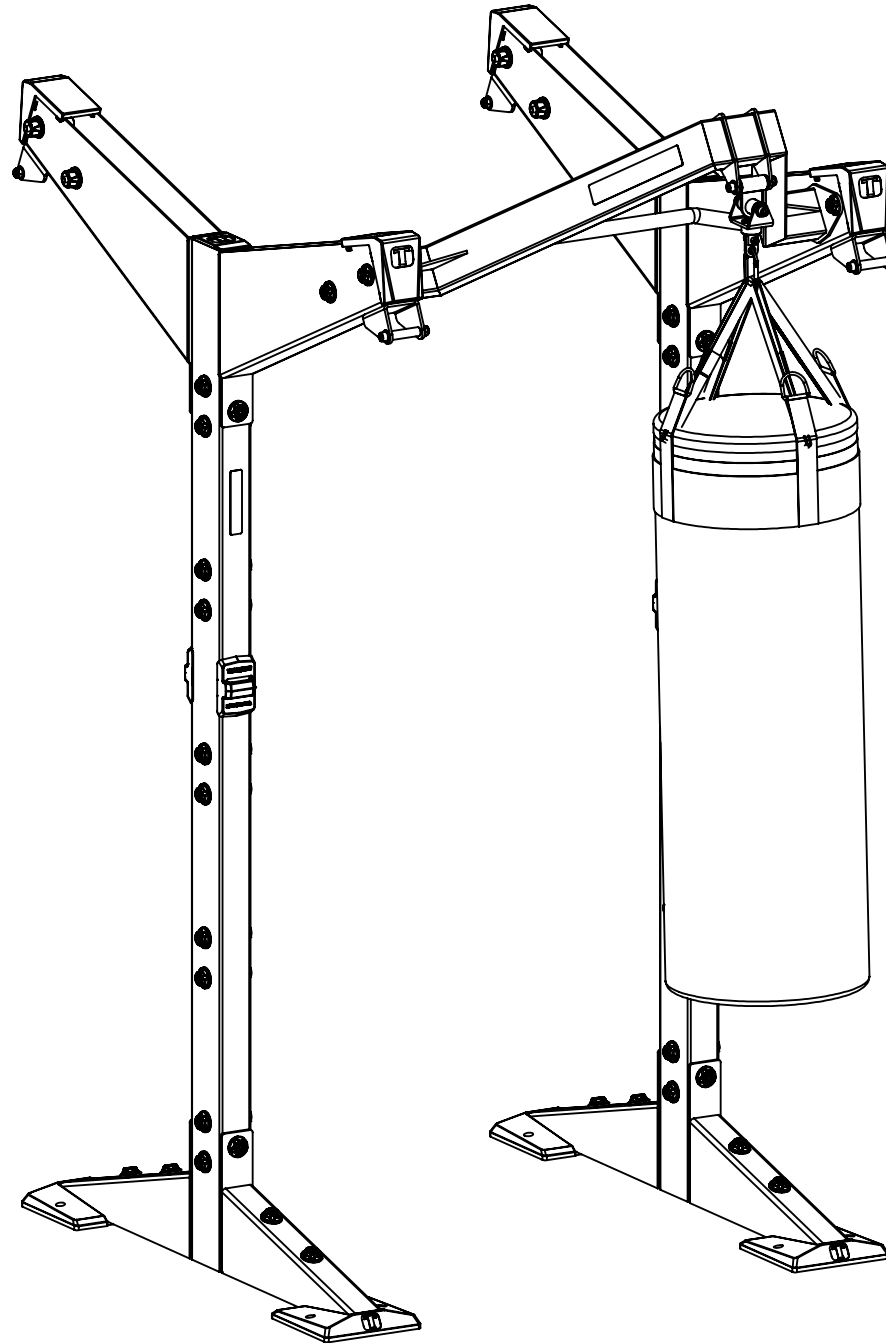

# 4' HEAVY BAG MODULE

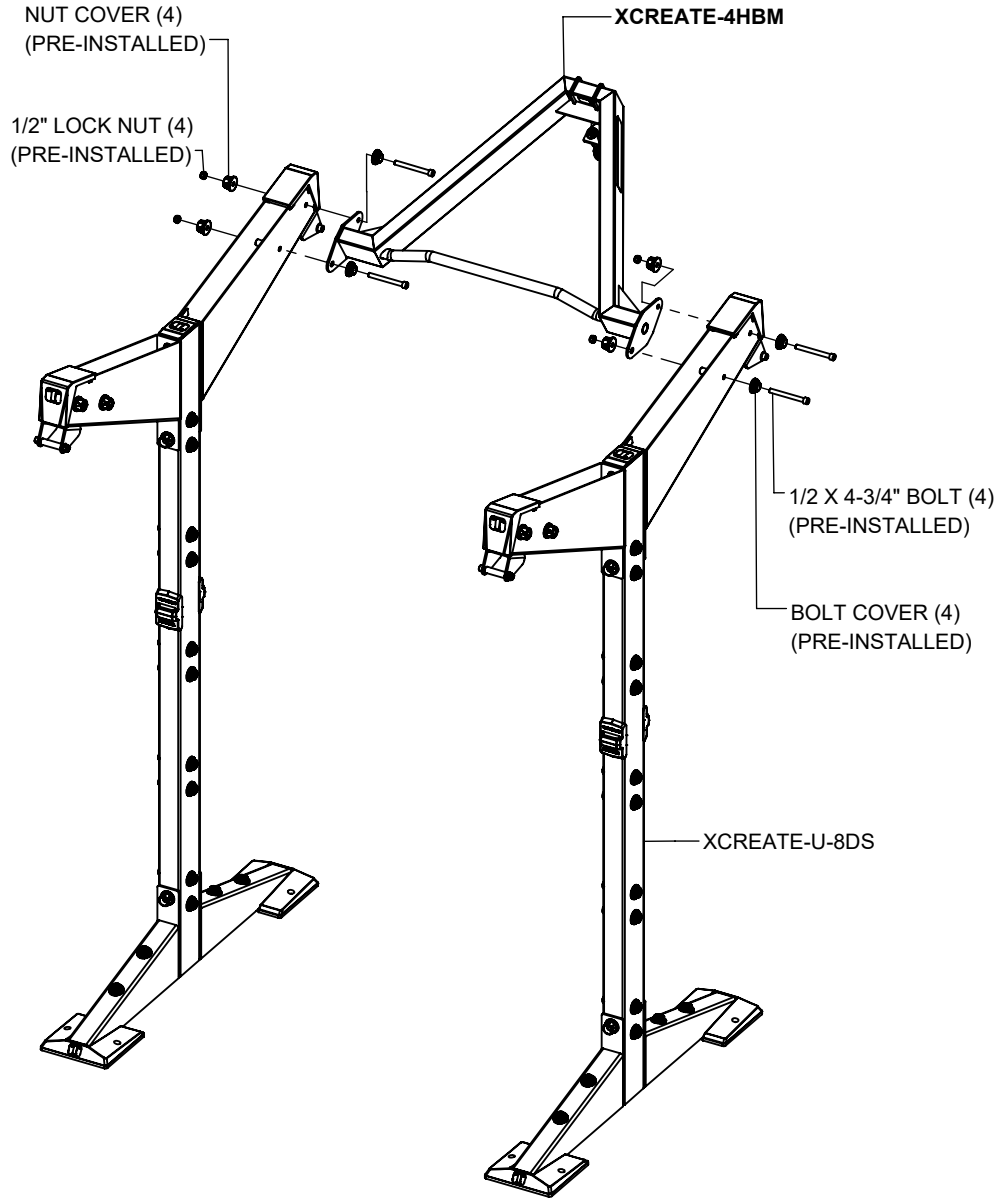
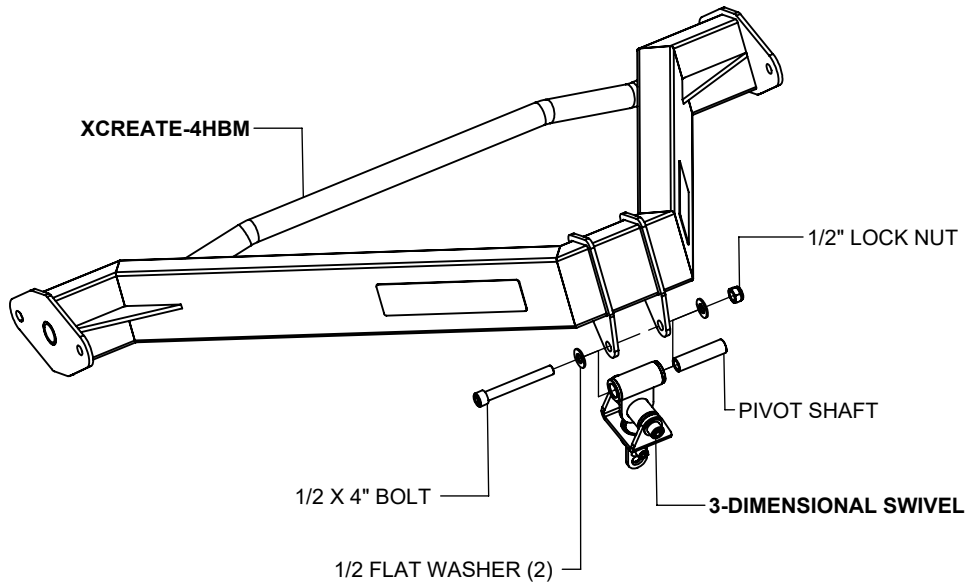

## NOTES:

**SECURELY** tighten all bolt connections in this step.

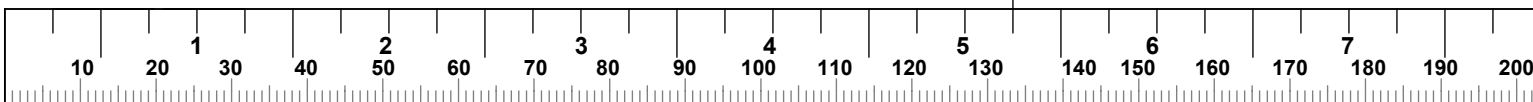

# MAT STORAGE AND ACCESSORY PINS

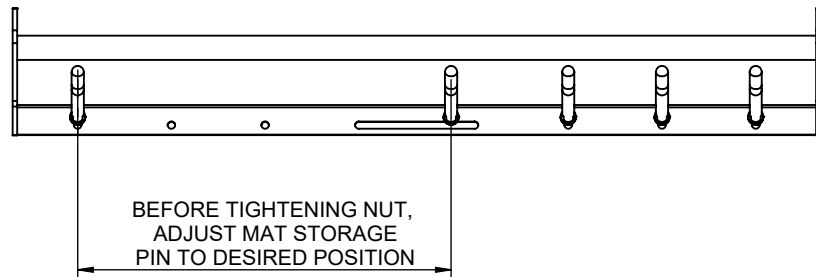
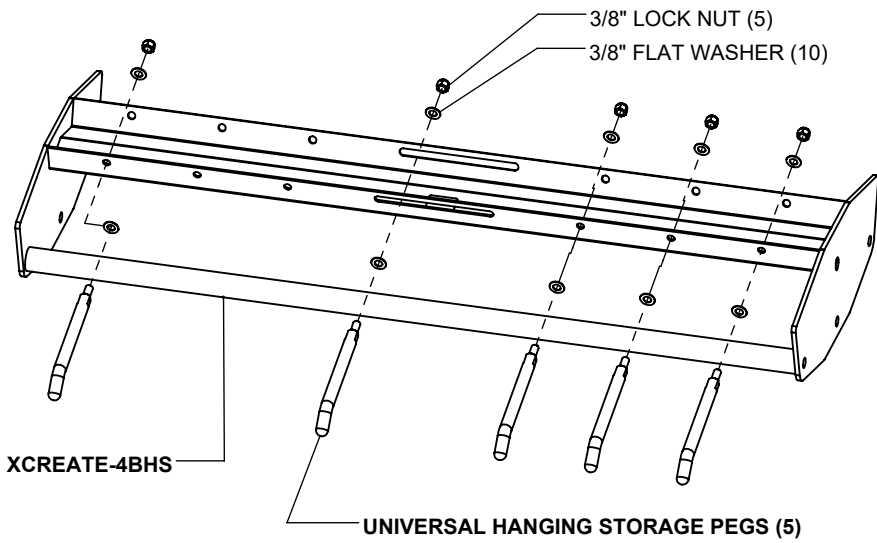

**NOTE:**

For the purpose of illustration the XCREATE-4BHS is shown. The XCREATE-4CSB, XCREATE-4BHS, XCREATE-6BHS can be assembled the same way.

**SECURELY** tighten all connections in this step.

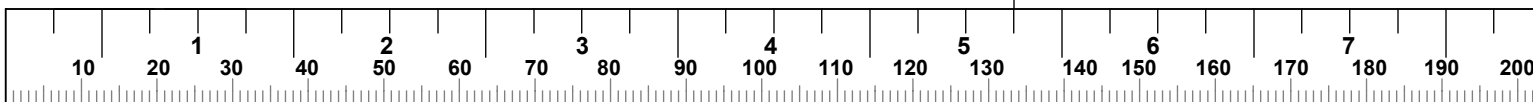
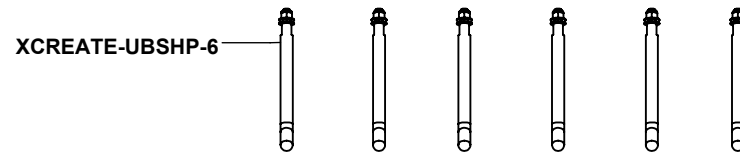
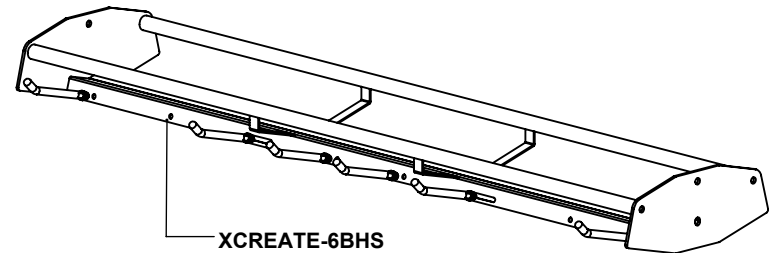
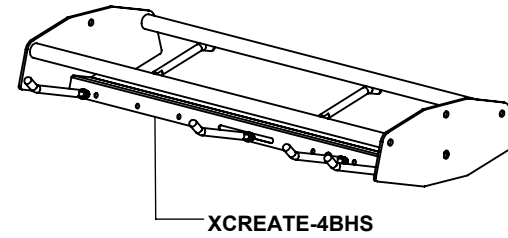
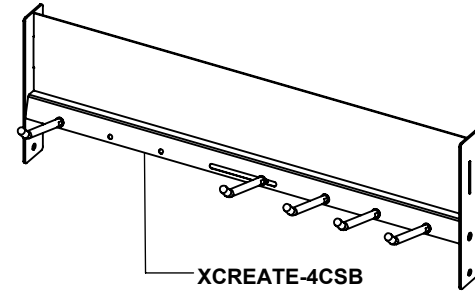

## ACCESSORY TRAY LABELS

ATTACH DESIRED  
LABEL TO EACH  
ACCESSORY TRAY  
SEE NOTE BELOW

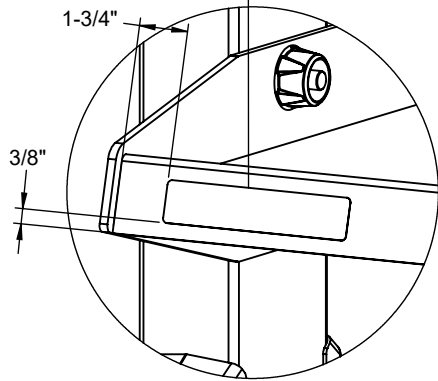

ACCESSORY LABEL

XCREATE-6TRAY (4)

XCREATE-4TRAY (4)

### **NOTE:**

If you are a professional contractor installing this system for a facility, leave these labels and instruction with manager or inquire what label to attach to each accessory tray.

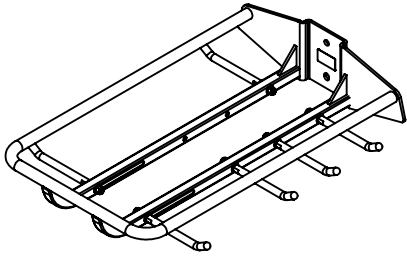

**XCREATE-BHSE**  
BALL AND HANGING  
STORAGE EXTENSION

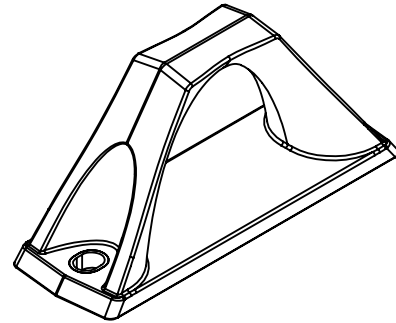

**XRACK-BRA**  
BATTLE ROPE ANCHOR

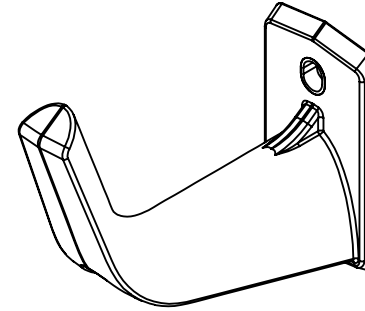

**XCREATE-HSH**  
HANGING STORAGE HOOK

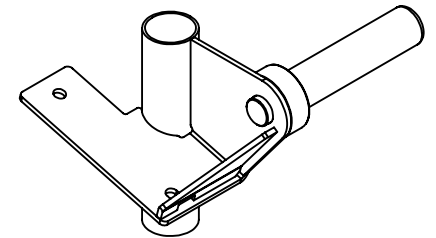

**XCREATE-DP**  
DOUBLE PLAY

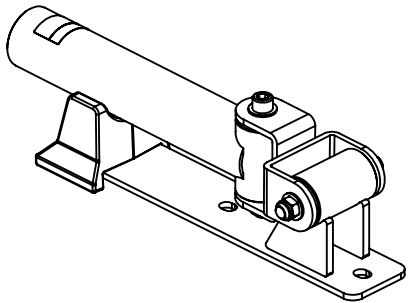

**XHMGRT**  
HORIZONTAL MOUNT  
GROUND ROTATIONAL TRAINER

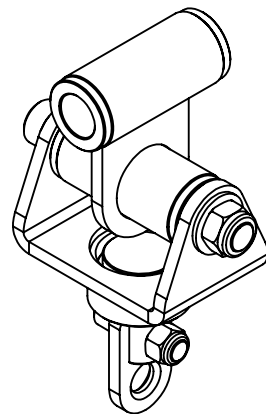

**XCREATE-3DS**  
3 DIMENSIONAL SWIVEL

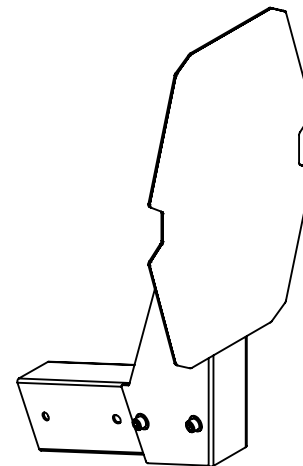

**XCREATE-BT**  
BALL TARGET

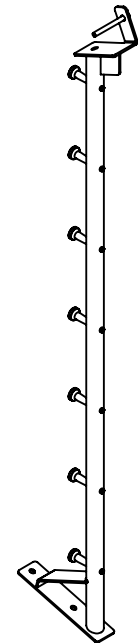

**XCREATE-RBA**  
RESISTANCE BAND ANCHOR

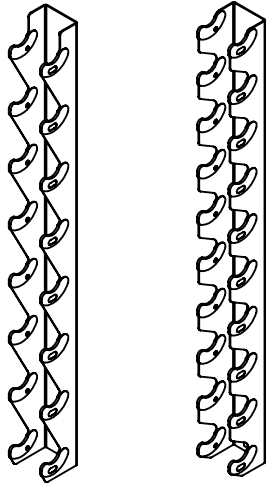

**XCREATE-VDS4 / VDS5**  
VERTICAL DUMBBELL  
STORAGE

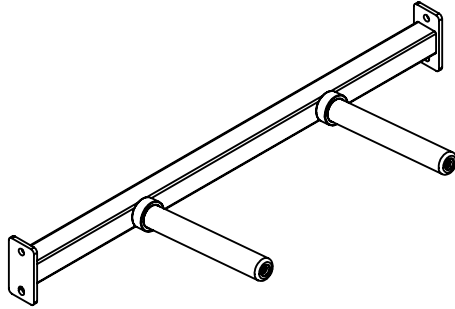

**XCREATE-4SSHWS**  
4' SINGLE SIDE HORIZONTAL  
WEIGHT STORAGE

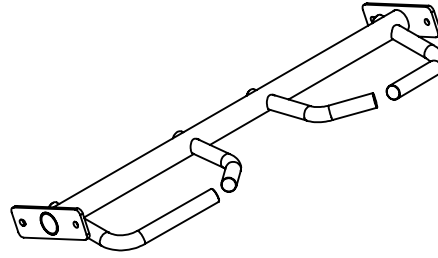

**XCREATE-4MGX**  
4' MULTI GRIP CROSS

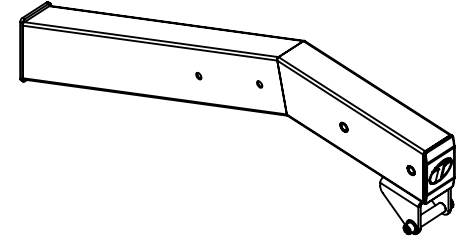

**XCREATE-TBE**  
TOP BOOM EXTENSION

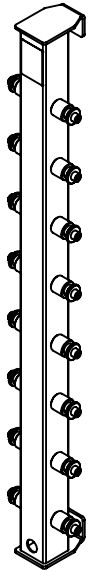

**XCREATE-AA**  
ATTACHMENT ANCHOR

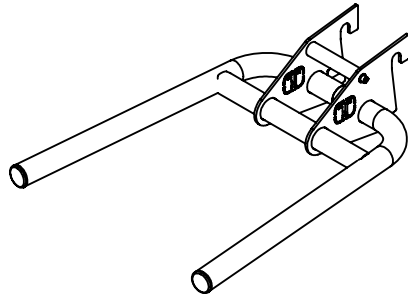

**XCREATE-DA**  
DIP ATTACHMENT

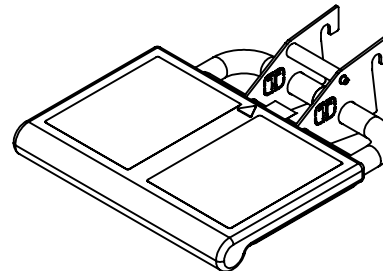

**XCREATE-PS**  
PLYO STEP

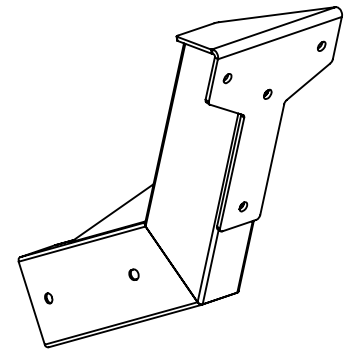

**XCREATE-AE**  
ATTACHMENT EXTENSION

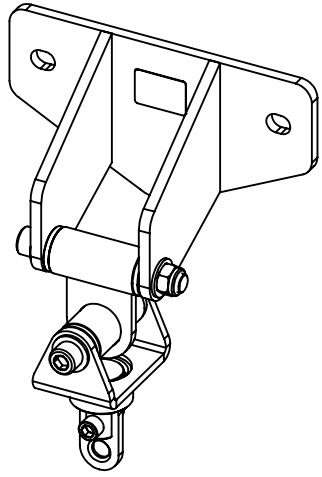

**XCREATE-3DSM**  
3 DIMENSIONAL SWIVEL W/MOUNT

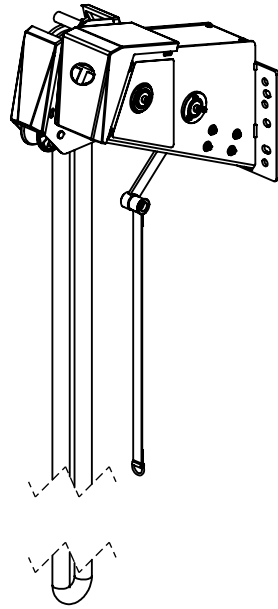

**XERT**  
RELENTLESS ROPE TRAINER

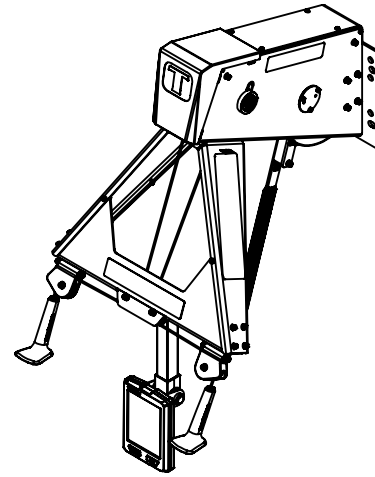

**XRR-SKI**  
RELENTLESS RIPPER

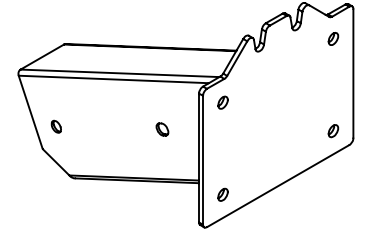

**XCREATE-BMXERT**  
BOOM MOUNT

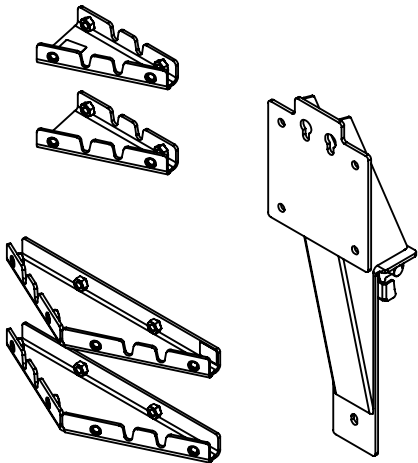

**XCREATE-SAM**  
SIDE ATTACHMENT MOUNT

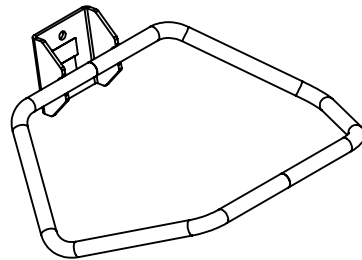

**XCREATE-SA-BOSU**  
BOSU STORAGE ATTACHMENT

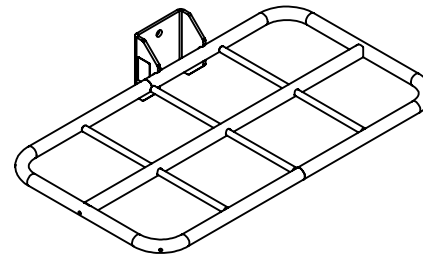

**XCREATE-FRS**  
FOAM ROLLER STORAGE

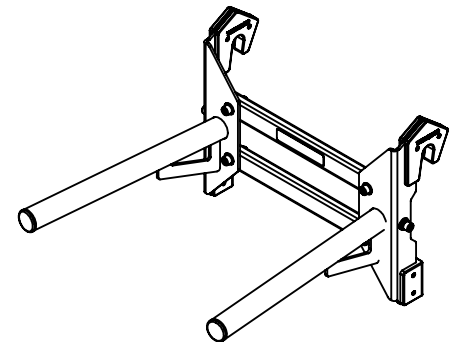

**XCREATE-SBDA**  
STALL BAR DIP ATTACHMENT

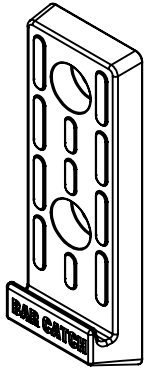

**BCSA**  
BAR CATCH STORAGE  
ATTACHMENT

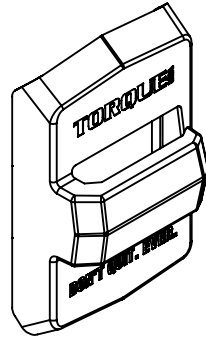

**XCREATE-HMSC**  
SUSPENSION CLIP

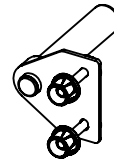

**CPWH**  
CHANGE PLATE WEIGHT HORN

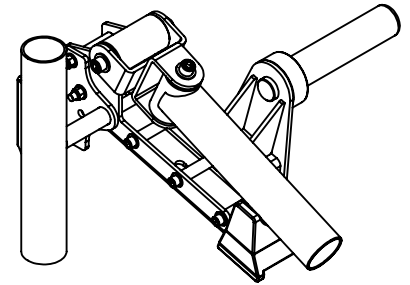
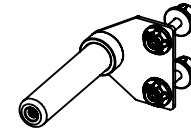

**XCREATE-TP**  
TRIPLE PLAY

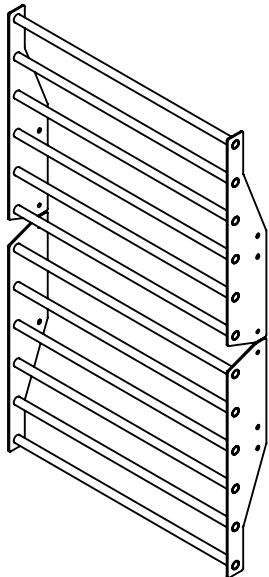

**4OSB**  
4' OFFSET STALL BARS

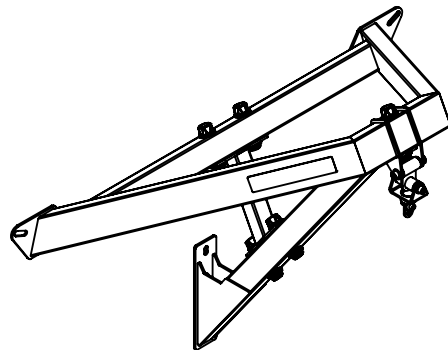

**DSUHBA**  
DUAL SIDED UNIVERSAL  
HEAVY BAG ATTACHMENT

**XCREATE-BHSE  
BALL & HANGING  
STORAGE EXTENSION**

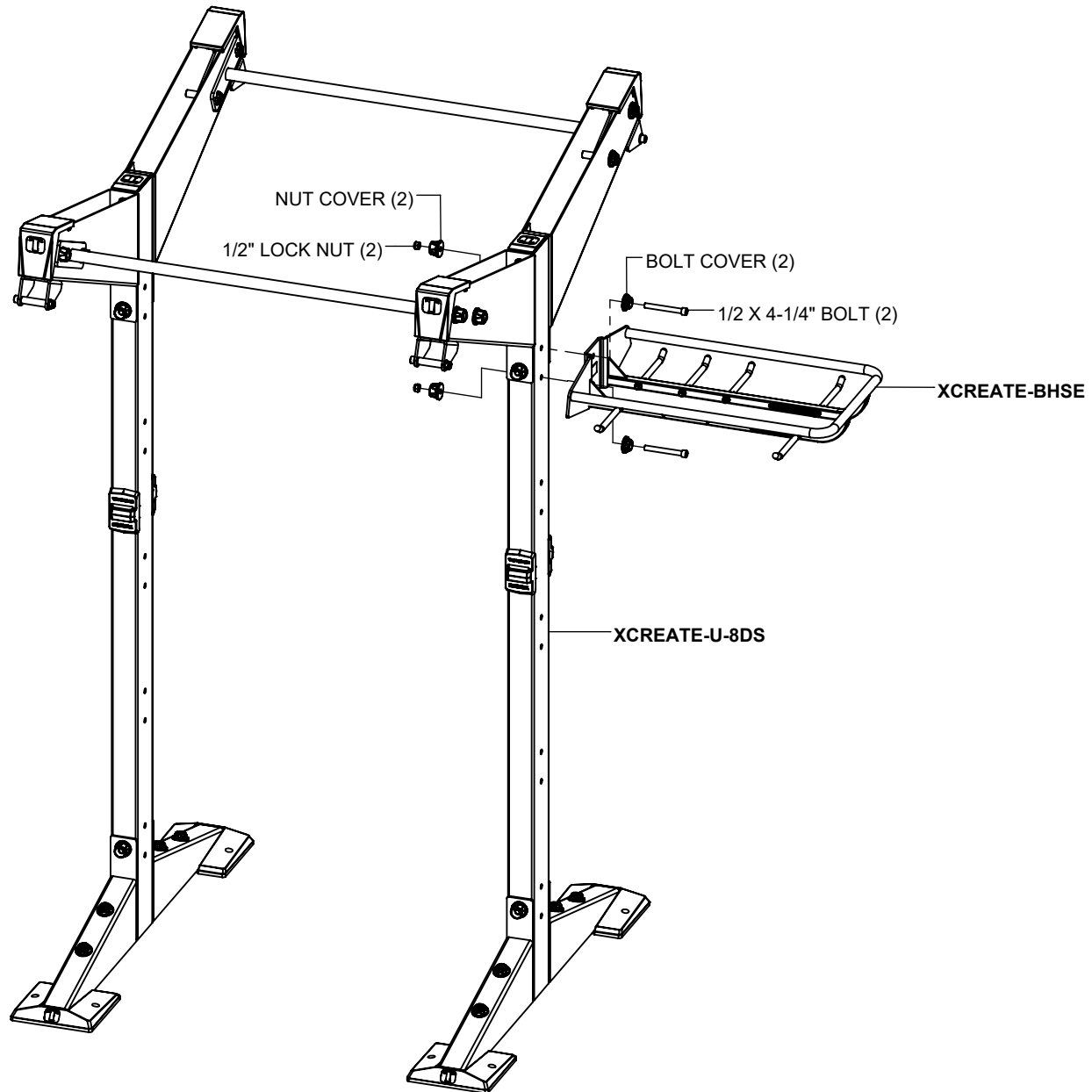

**NOTES:**

**SECURELY** tighten all bolt connections in this step.

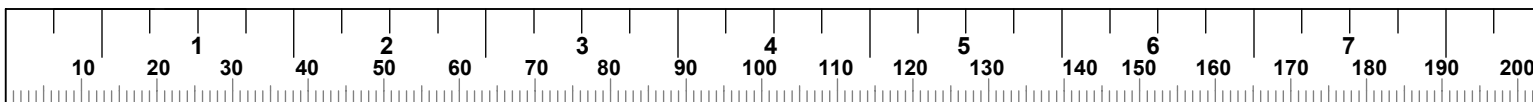

**XRACK-BRA  
BATTLE ROPE ANCHOR**

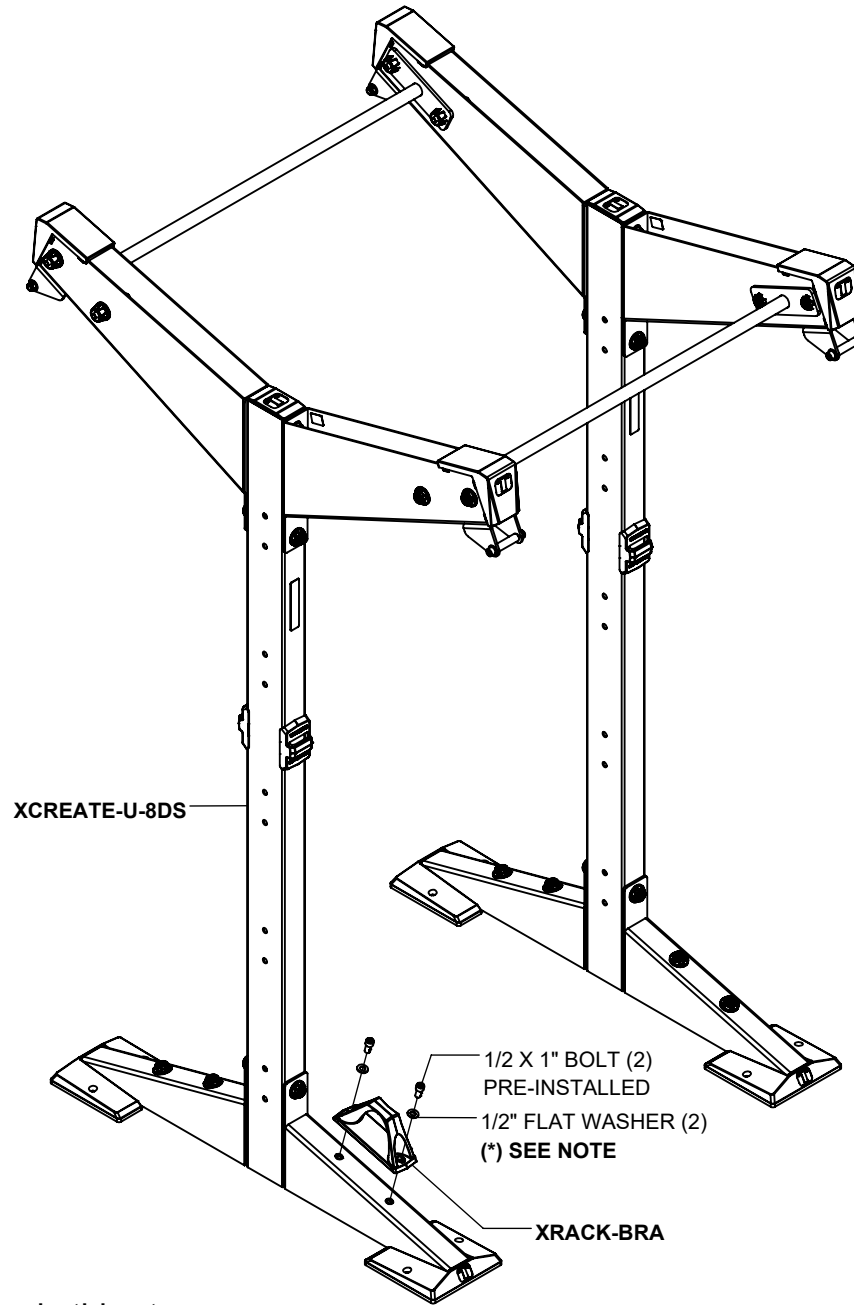

**NOTES:**

**SECURELY** tighten all bolt connections in this step.

(\*\*) **HARDWARE COVERS CANNOT** be used in this step.

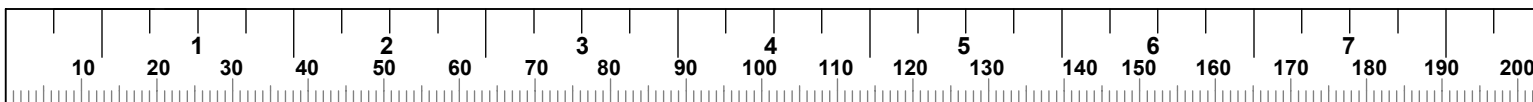

**XCREATE-HSH  
HANGING STORAGE HOOK**

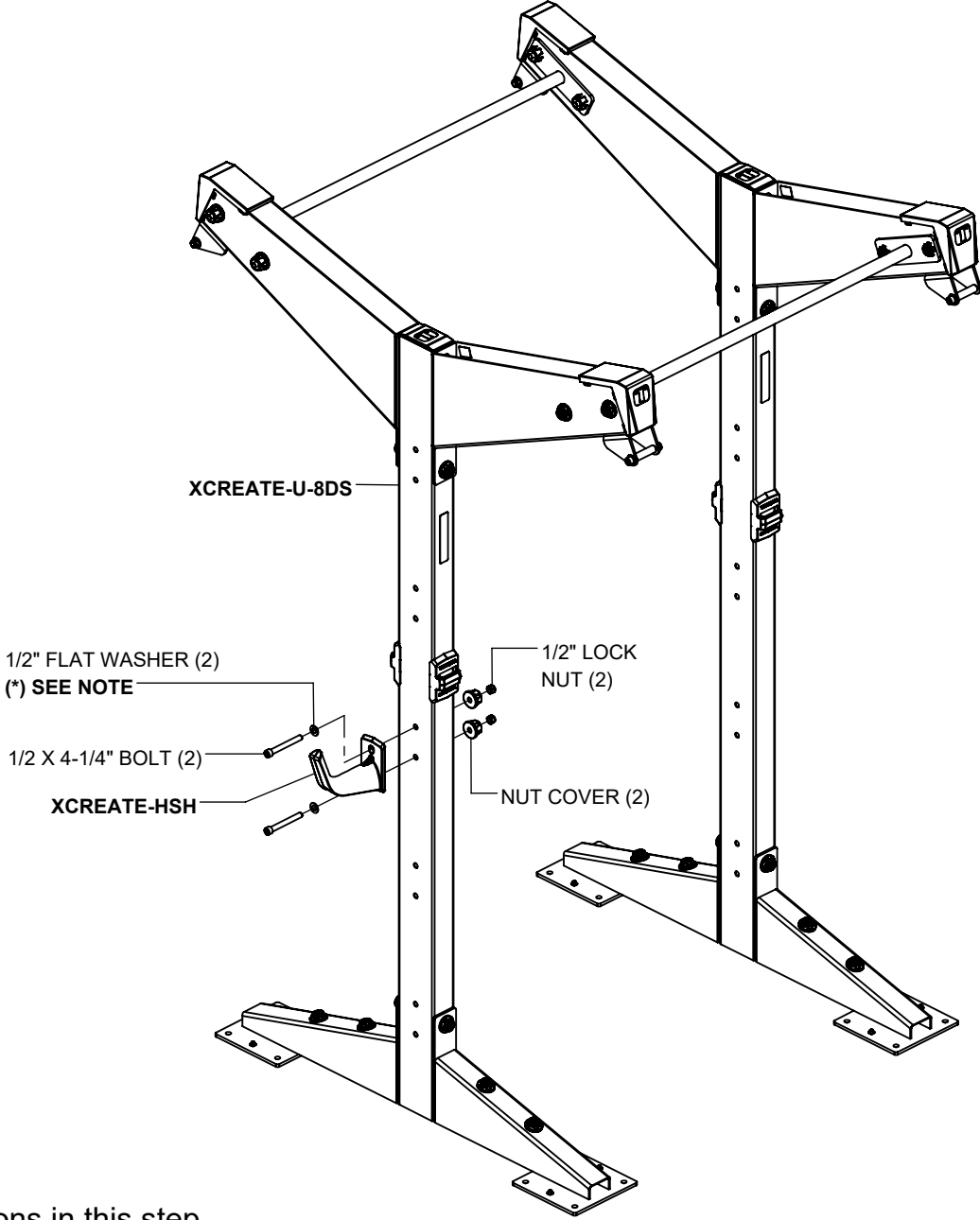

**NOTES:**

**SECURELY** tighten all bolt connections in this step.

**(\*\*)** HARDWARE COVER **CANNOT** be used on **HSH** side.

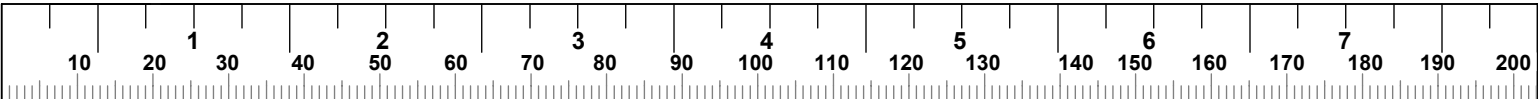

**XCREATE-DP  
DOUBLE PLAY (BAR & PLATE STORAGE)**

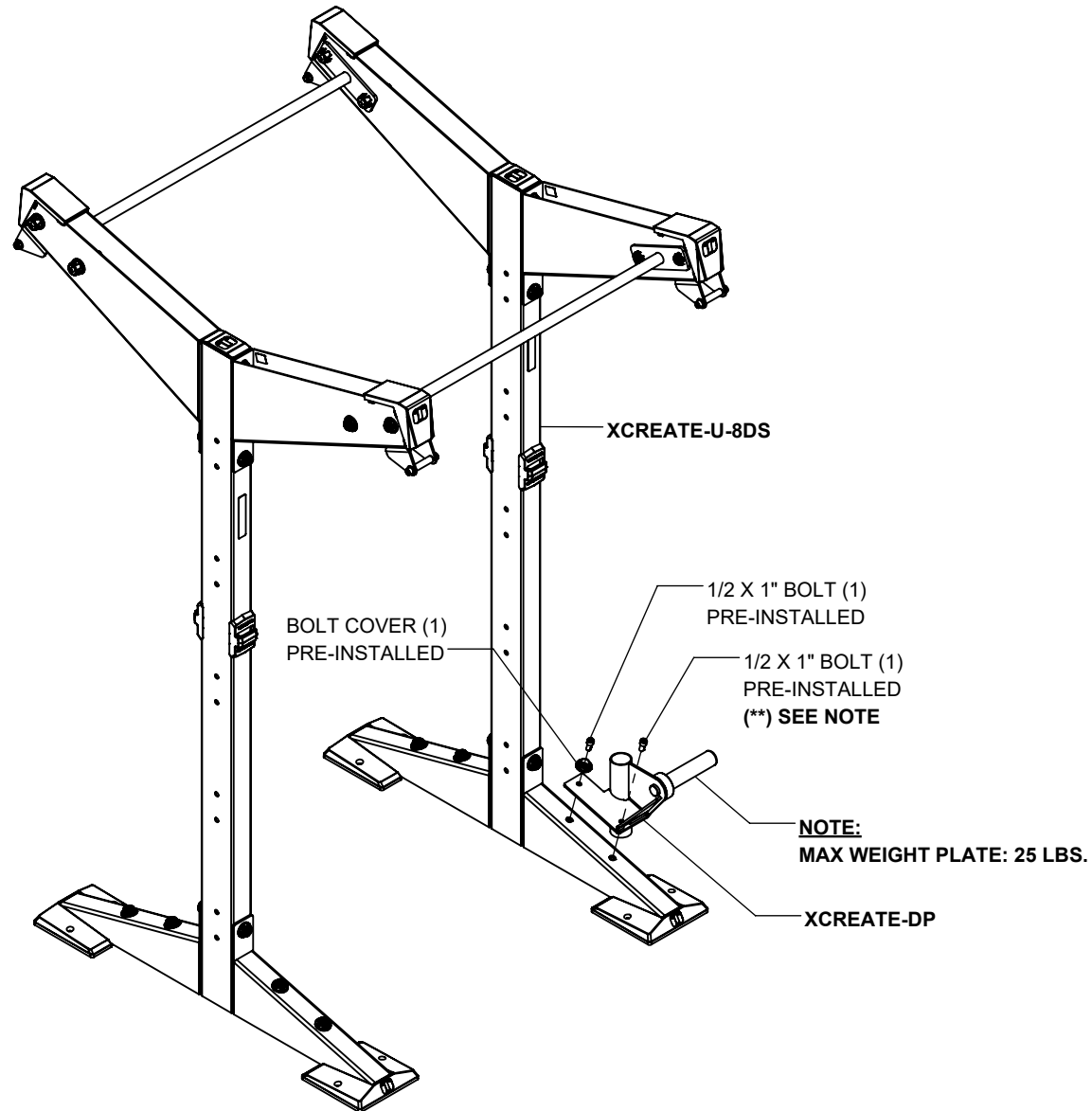

**NOTES:**

**SECURELY** tighten all bolt connections in this step.

(\*\*) **HARDWARE COVER CANNOT** be used in place of washer.

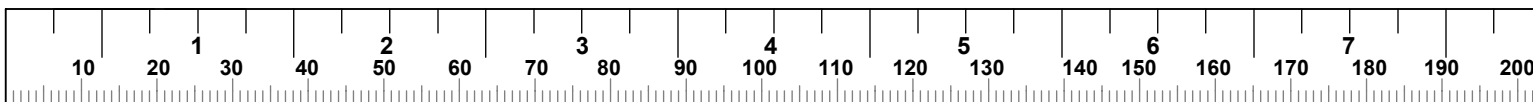

**XHMGRT  
HORIZONTAL MOUNT GROUND  
ROTATIONAL TRAINER**

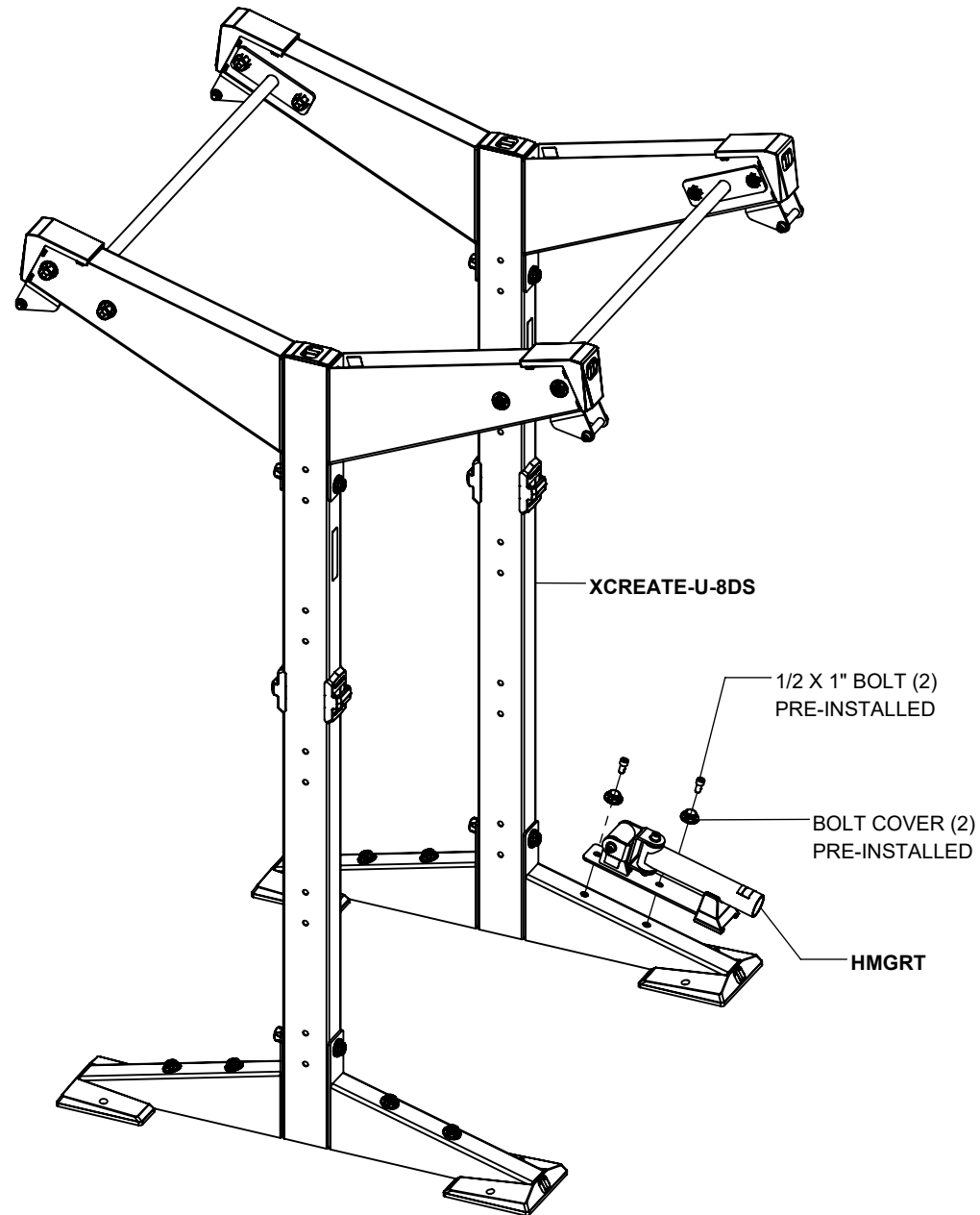

**NOTES:**

**SECURELY** tighten all bolt connections in this step.

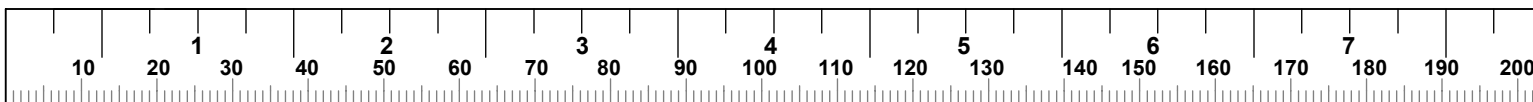

**XCREATE-3DS**  
**3 DIMENSIONAL SWIVEL**

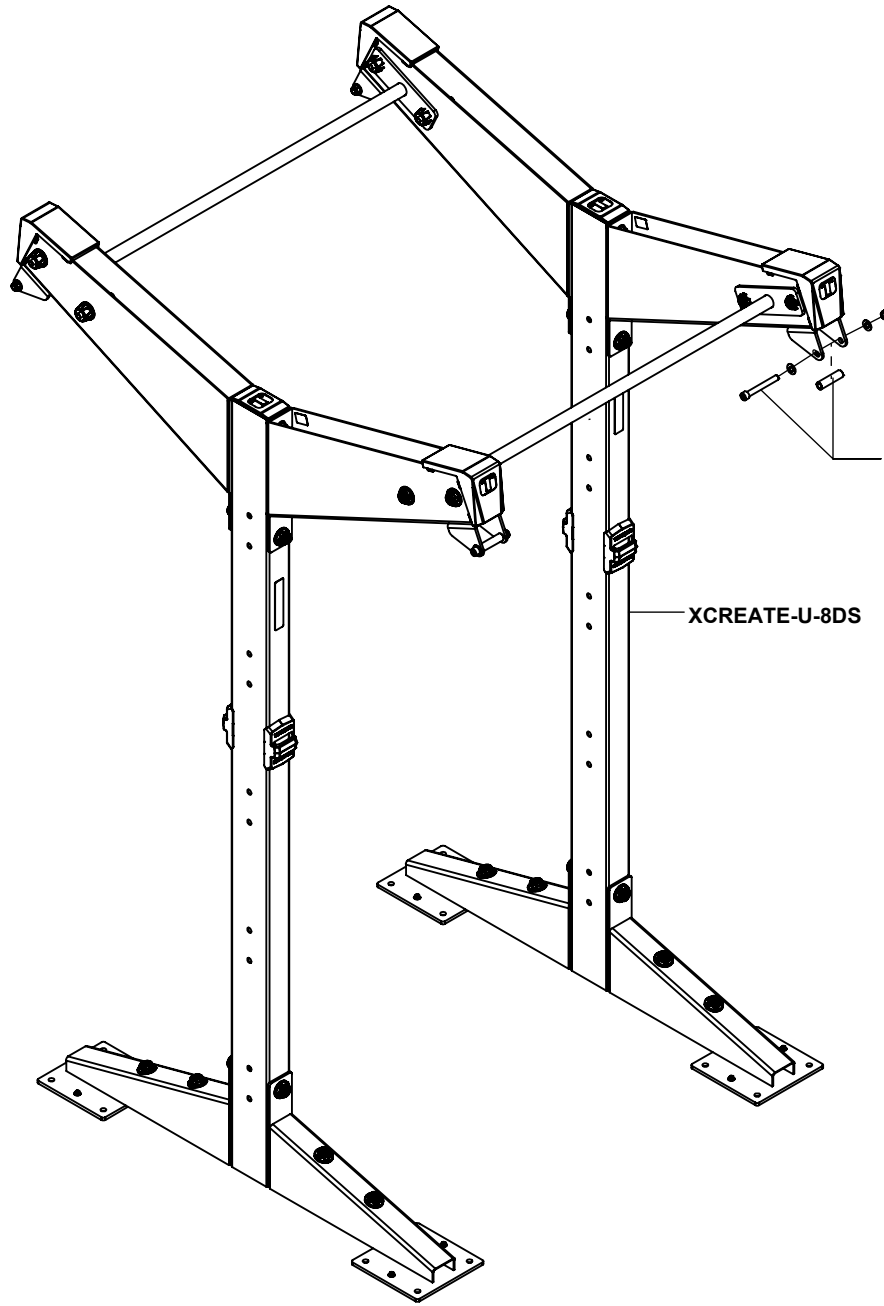

**NOTE:**  
TEMPORARILY REMOVE BOLT,  
SPACER, WASHERS AND NUT

XCREATE-U-8DS

**XCREATE-3DS**  
**3-DIMENSIONAL SWIVEL**

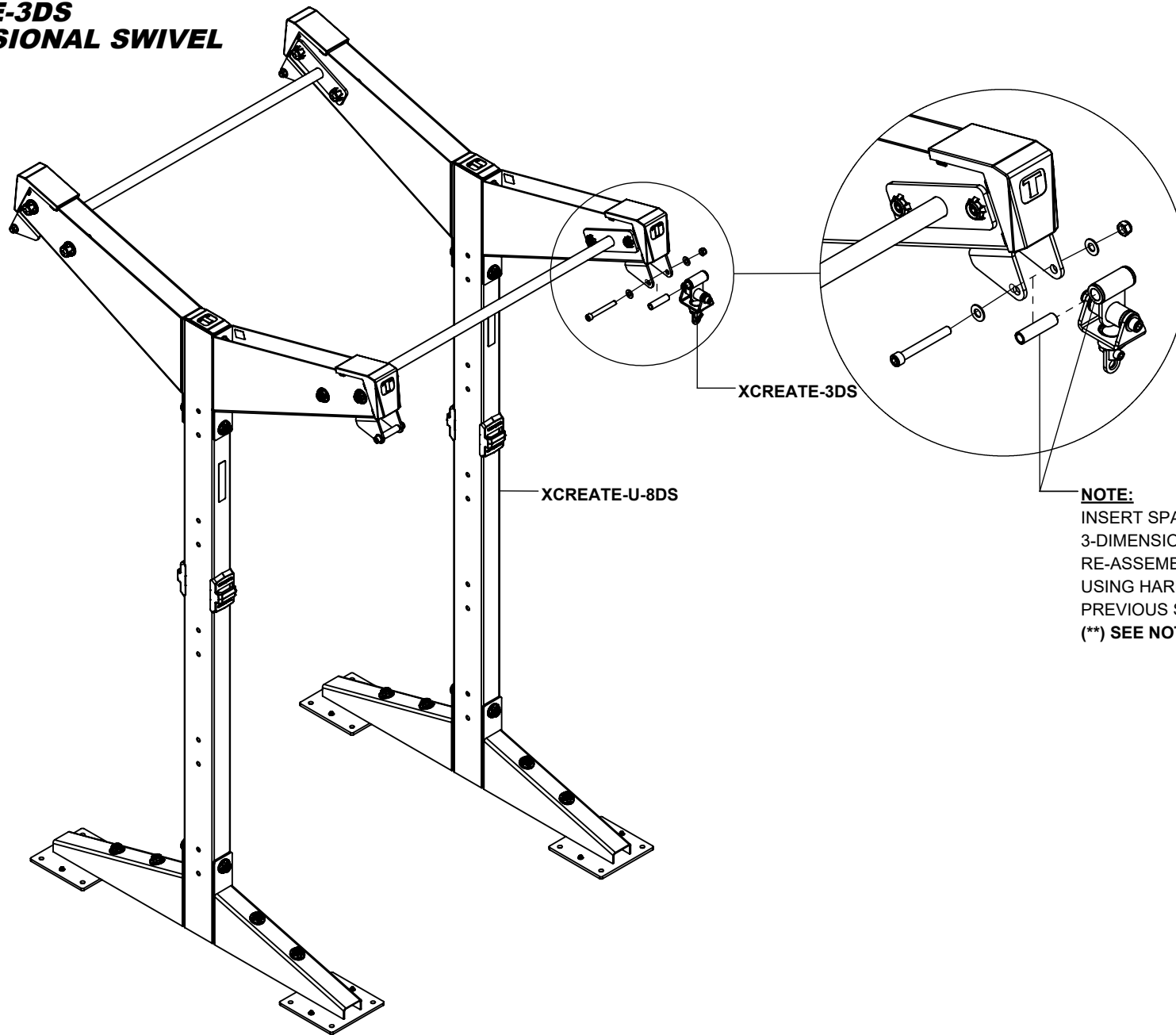

**NOTES:**

**SECURELY** assemble bolt connection in this step.

(\*\*) **HARDWARE COVERS** **CANNOT** be used in place of washers in this step.

# **XCREATE-BT BALL TARGET**

**NOTE:**

REMOVE SPACERS  
(2) AND DISCARD

**NOTE:**

REMOVE END CAP  
AND DISCARD

**NOTE:**

TEMPORARILY REMOVE  
BOLTS, HARDWARE COVERS AND NUTS

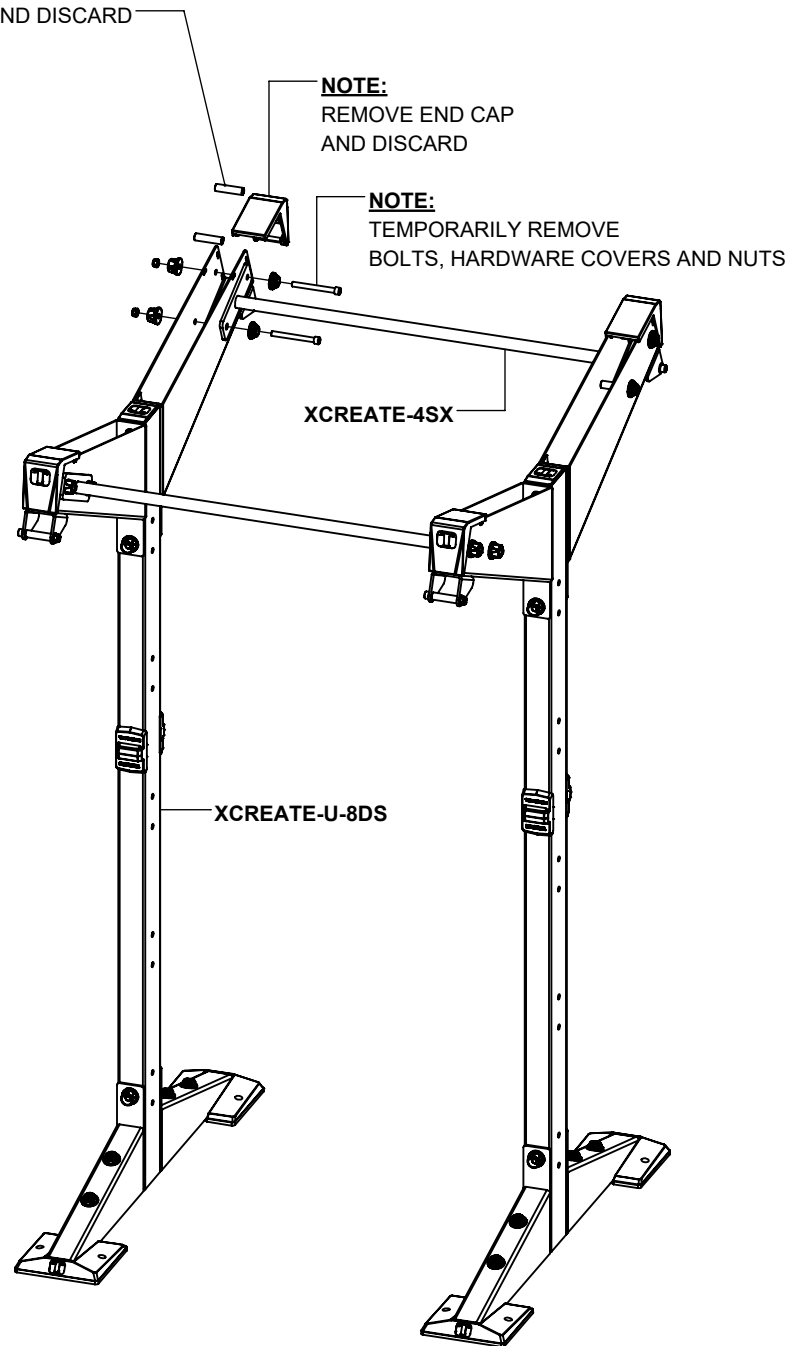

# ***XCREATE-BT BALL TARGET***

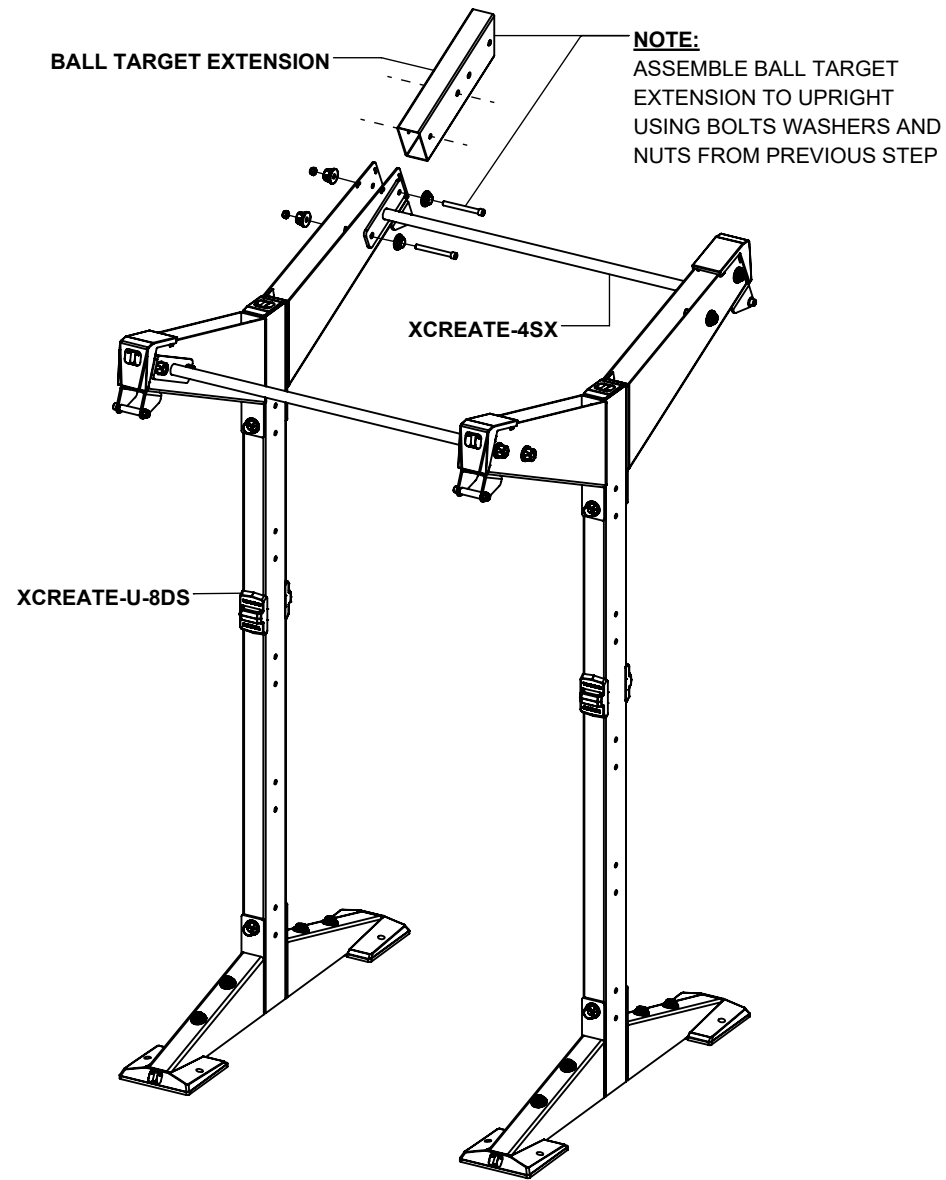

## **NOTES:**

**LOOSELY** assemble bolt connections in this step.

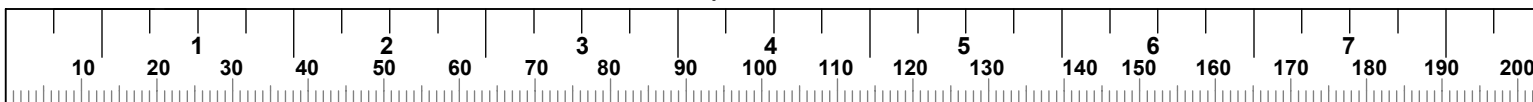

**XCREATE-BT  
BALL TARGET**

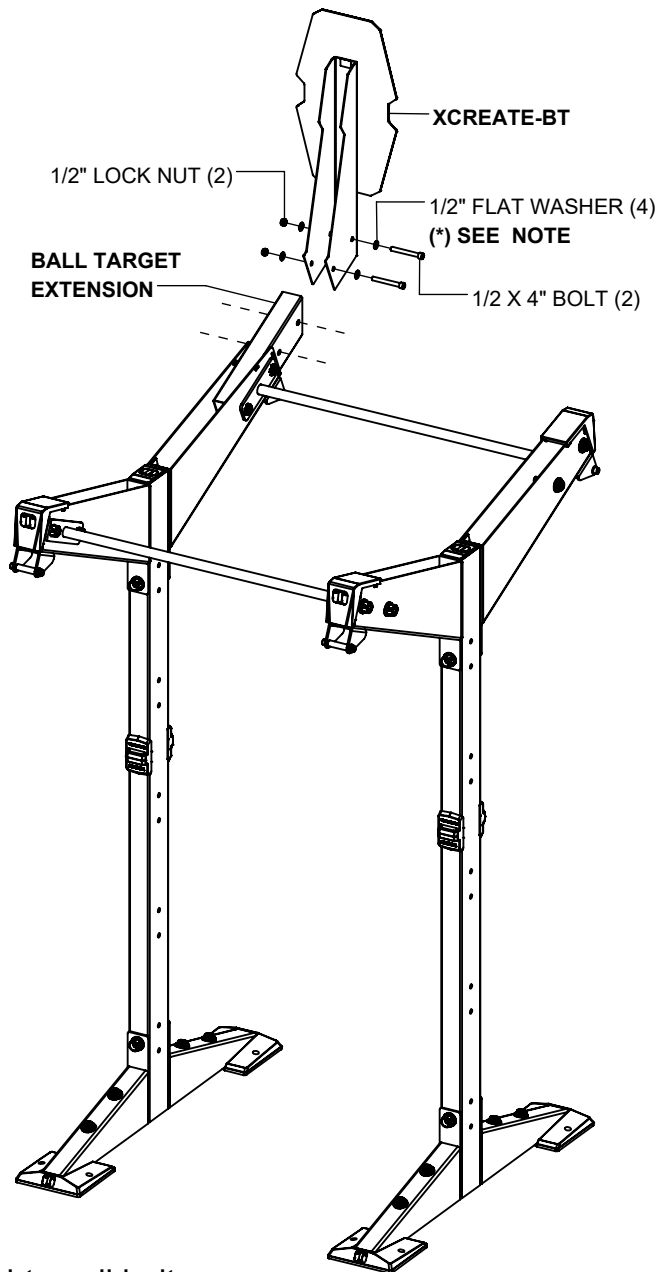

**NOTES:**

After this step has been completed, **SECURELY** tighten all bolt connections from the last two steps.

(\*) **HARDWARE COVERS** CAN be used in place of washers in this step.

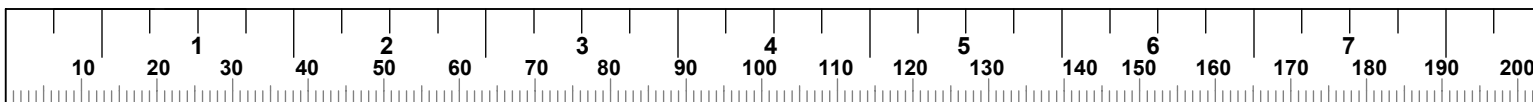

**XCREATE-RBA  
RESISTANCE BAND ANCHOR**

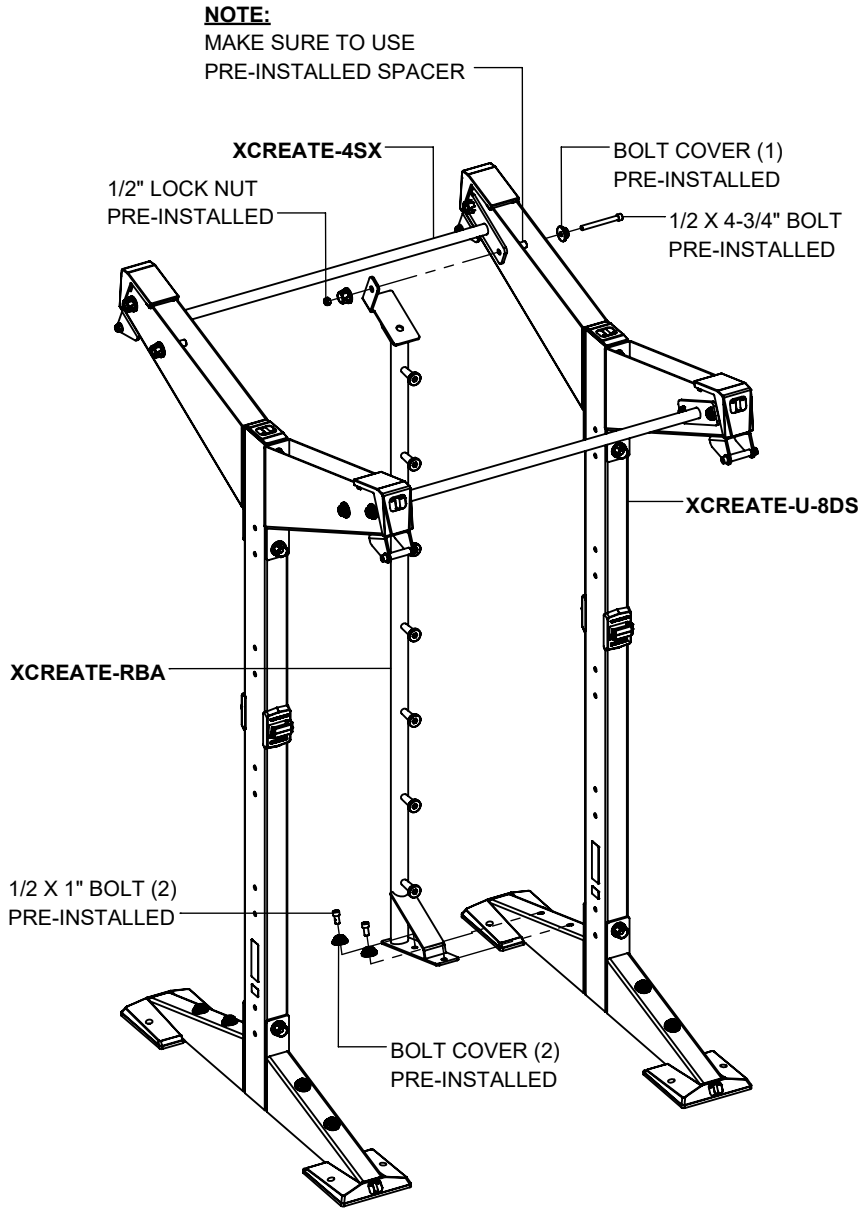

**NOTES:**

**SECURELY** tighten all bolt connections in this step.

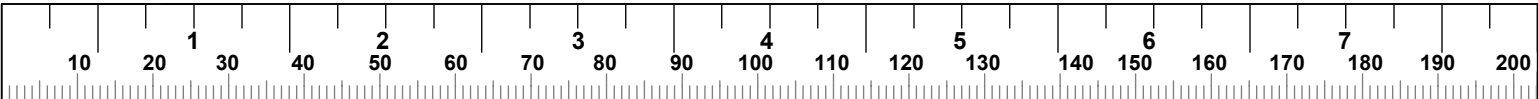

**XCREATE-VDS4 AND VDS5  
VERTICAL DUMBBELL STORAGE**

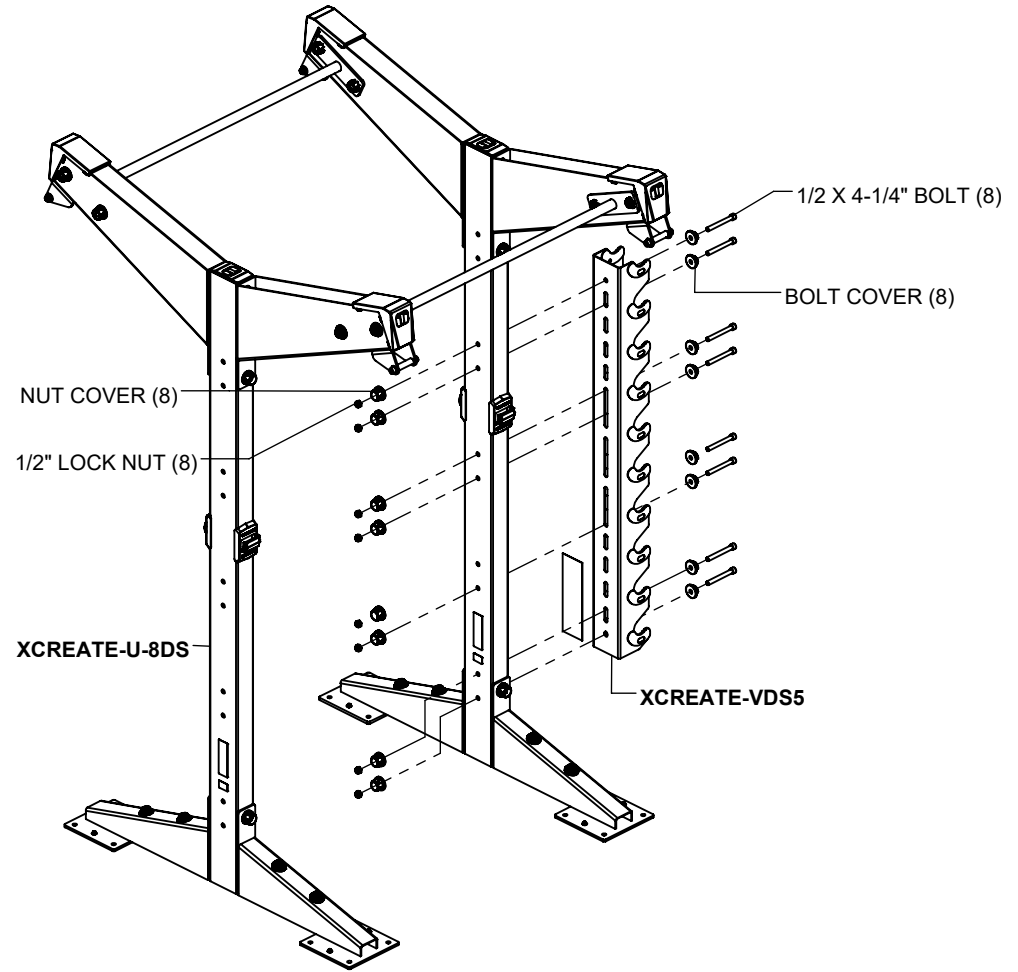
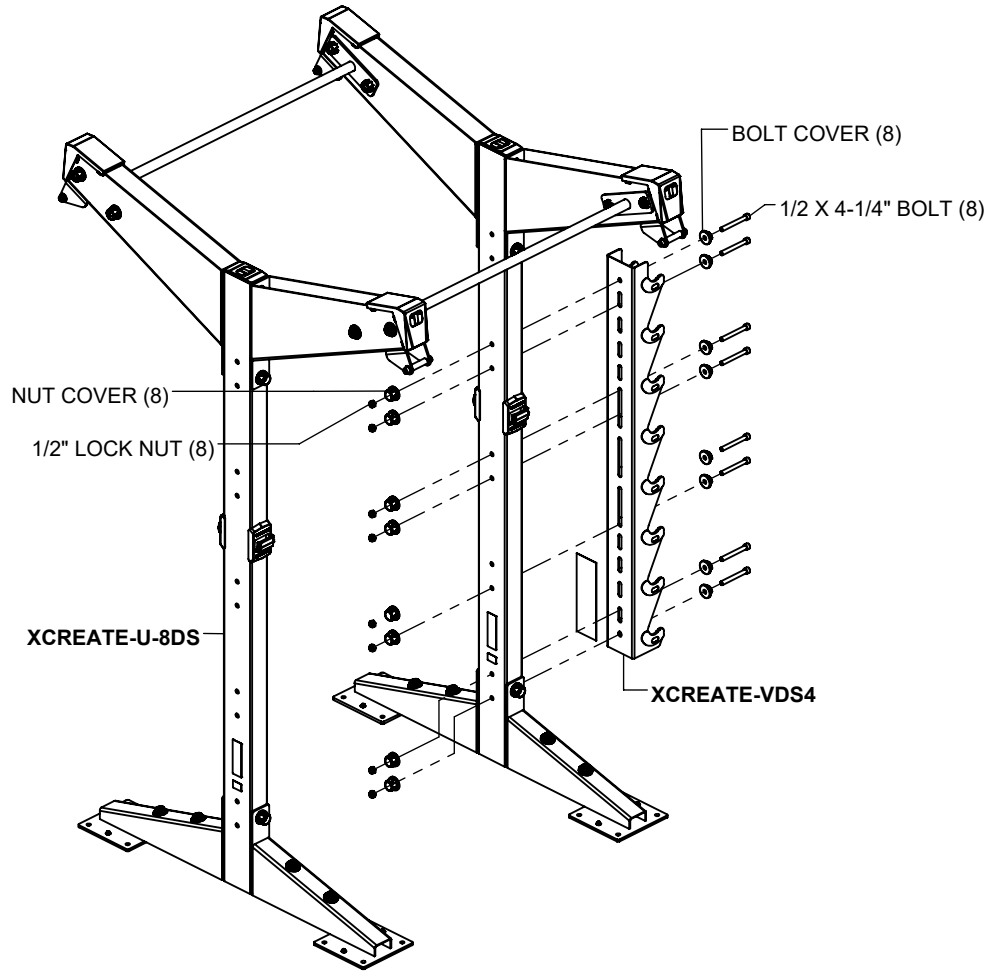

**NOTES:**

**SECURELY** tighten all bolt connections in this step.

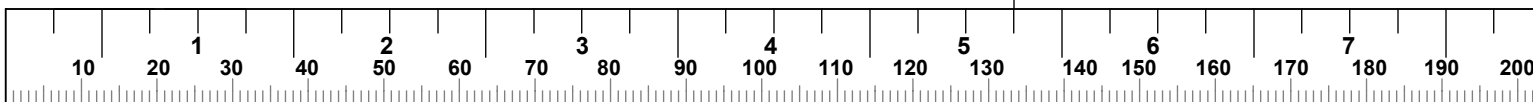

**XCREATE-4MGX  
4' MULTI GRIP CROSS**

**NOTE:**

REMOVE END CAPS PRIOR  
TO ASSEMBLY RE-ATTACH  
END CAPS AFTER ASSEMBLY (2)

NUT COVER (4)  
(PRE-INSTALLED)

1/2" LOCK NUT (4)  
(PRE-INSTALLED)

**NOTE:**

MAKE SURE TO USE PRE-  
INSTALLED SPACERS (4)

BOLT COVER (4)  
(PRE-INSTALLED)

1/2 X 4-3/4" BOLT (4)  
(PRE-INSTALLED)

XCREATE-4MGX

XCREATE-U-8DS (2)

**NOTES:**

**SECURELY** tighten all bolt connections in this step.

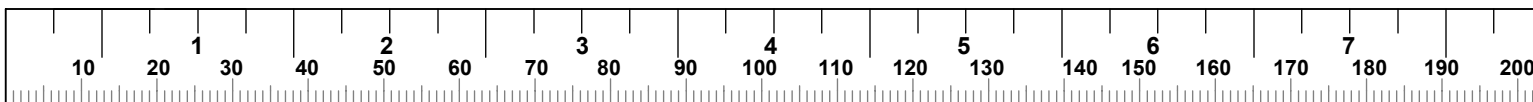

**XCREATE-4SSHWS**  
**4' SINGLE SIDE HORIZONTAL WEIGHT STORAGE**

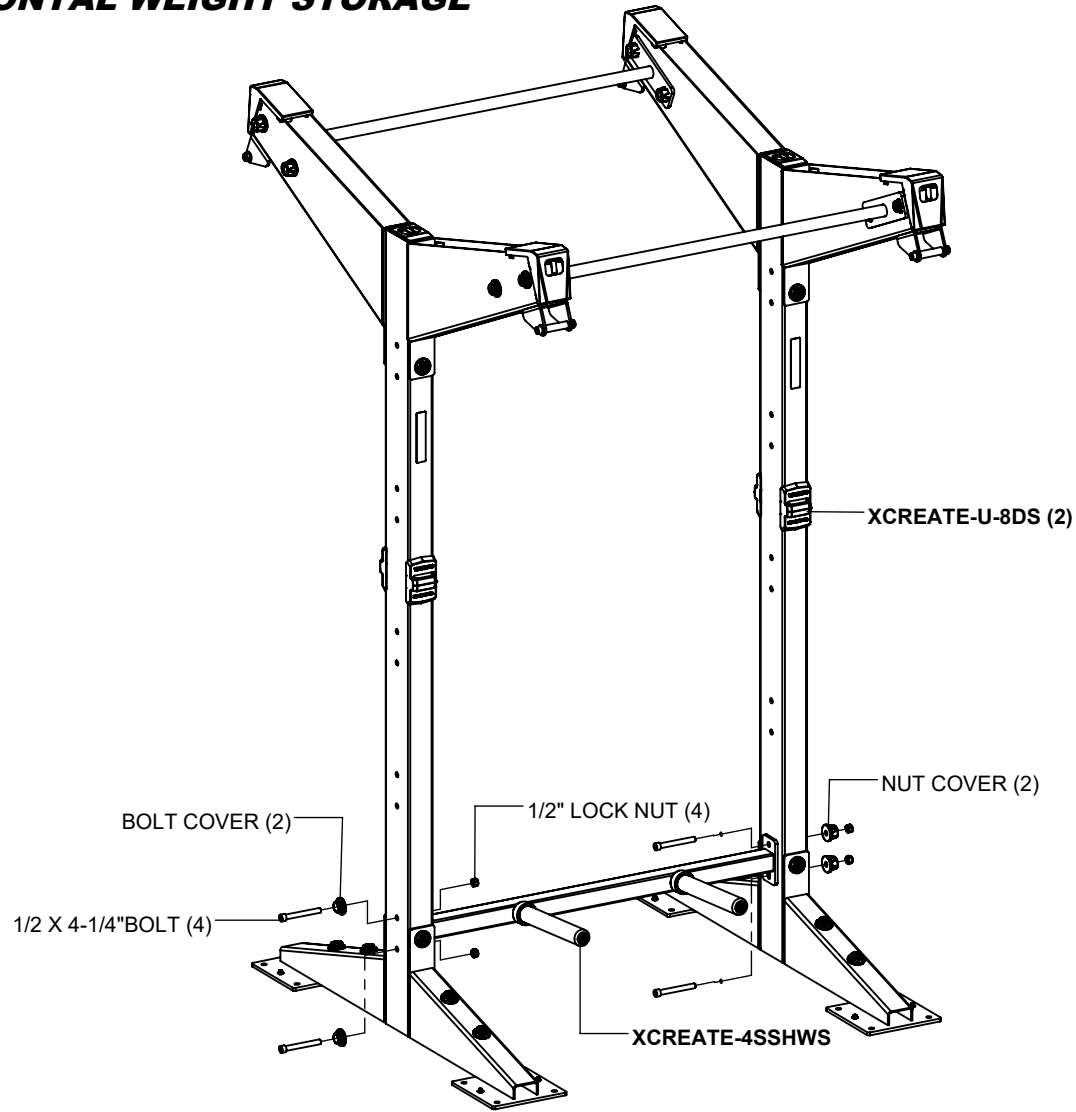

**NOTES:**

**SECURELY** tighten all bolt connections in this step.

(\*) **HARDWARE COVERS CANNOT** be used on plate side.

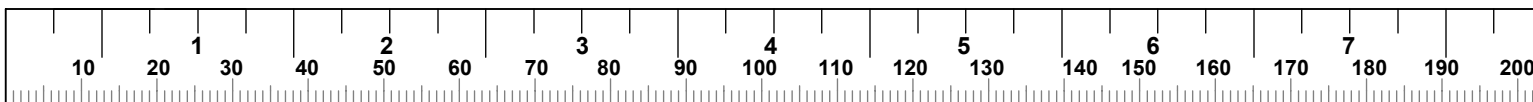

**XCREATE-TBE  
TOP BOOM EXTENSION**

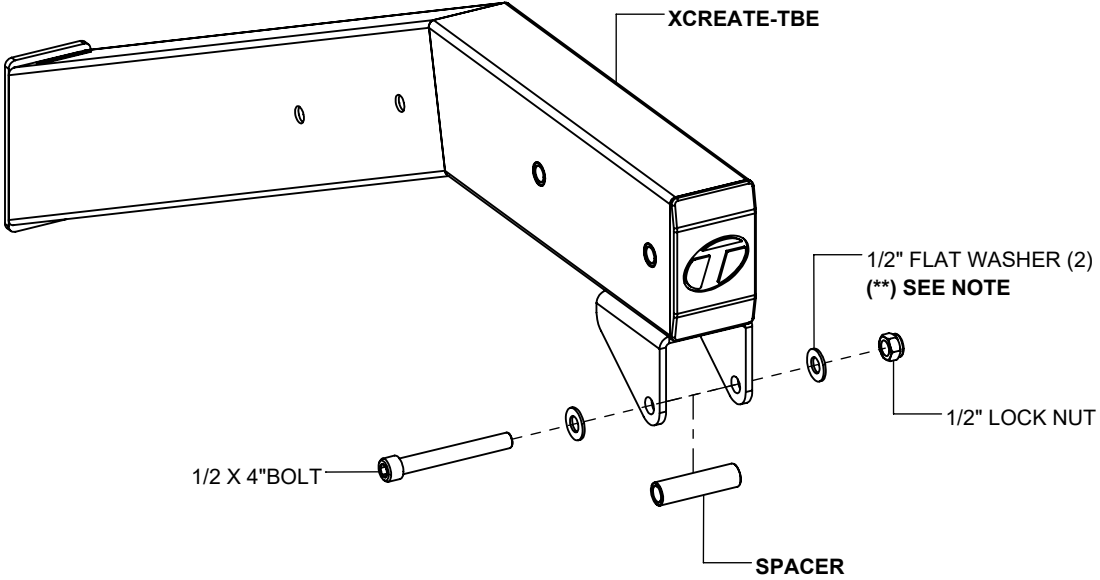

**NOTES:**

**SECURELY** tighten bolt connection in this step.

(\*\*) **HARDWARE COVERS CANNOT** be used in place of washers in this step.

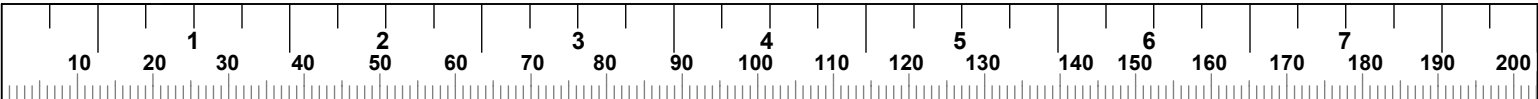

**XCREATE-TBE  
TOP BOOM EXTENSION**

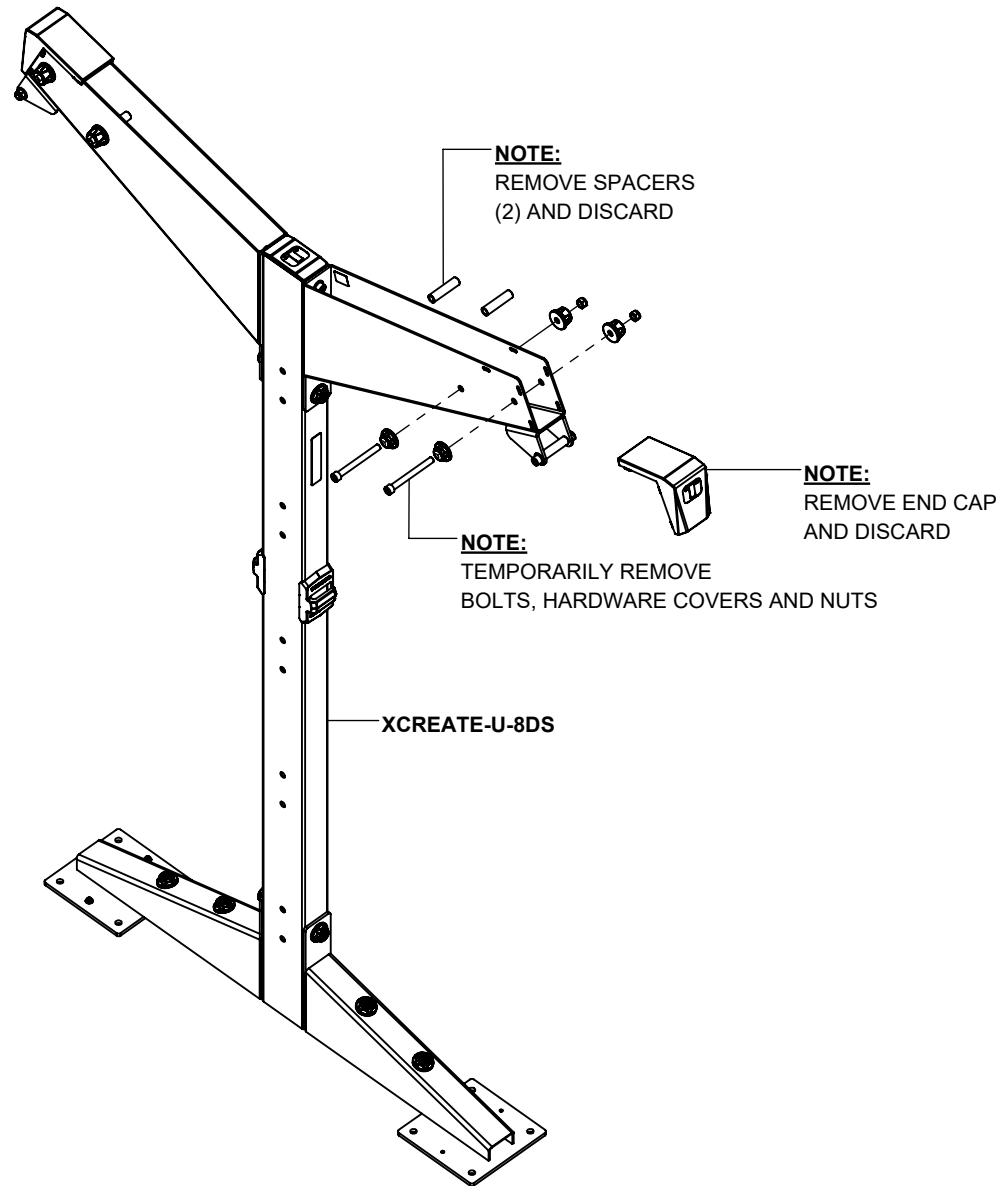

**NOTE:**

Repeat this step for as many TOP BOOM EXTENSIONS there are to assemble.

**XCREATE-TBE  
TOP BOOM EXTENSION**

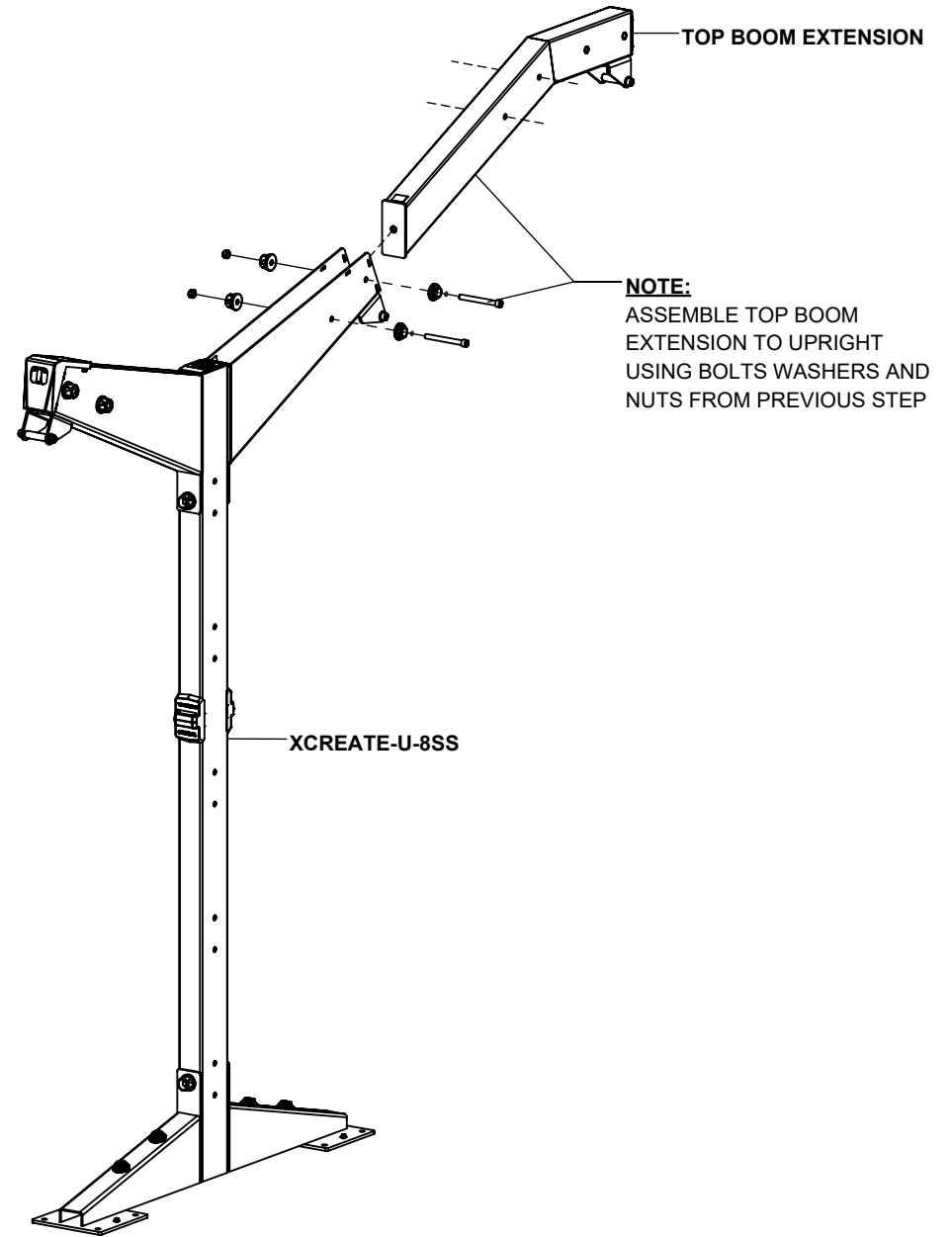

**NOTES:**

Repeat this step for as many TOP BOOM EXTENSIONS there are to assemble.

If only one TOP BOOM EXTENSION is being assembled, then **SECURELY** tighten all bolt connections in this step.

If joining two TOP BOOM EXTENSIONS together, then keep all bolt connections loose until next step.

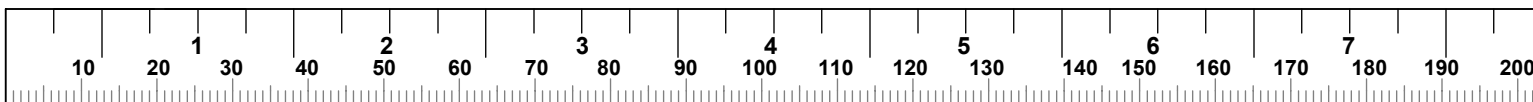

# XCREATE-TBE TOP BOOM EXTENSION

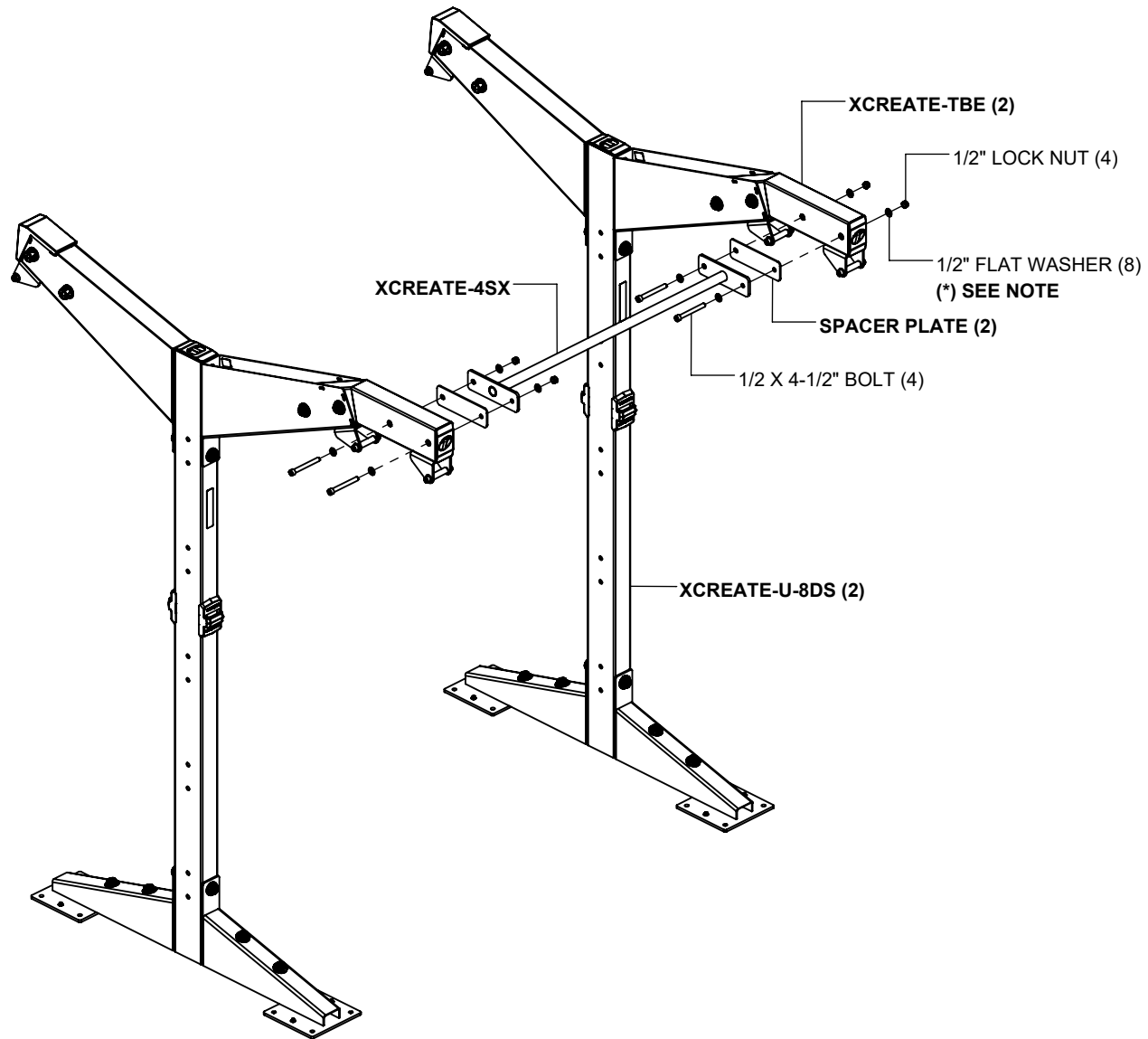

## NOTES:

**SECURELY** tighten all bolt connections in this step.

(\*) **HARDWARE COVERS** CAN be used in place of washers in this step. (SEE PAGE 3).

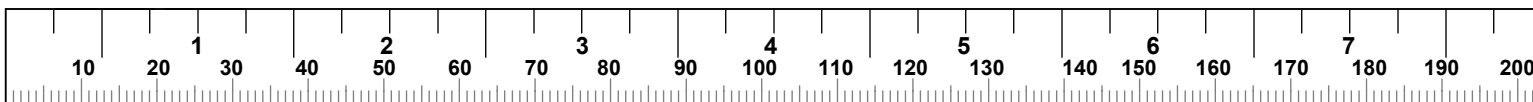

# XCREATE-AA ATTACHMENT ANCHOR

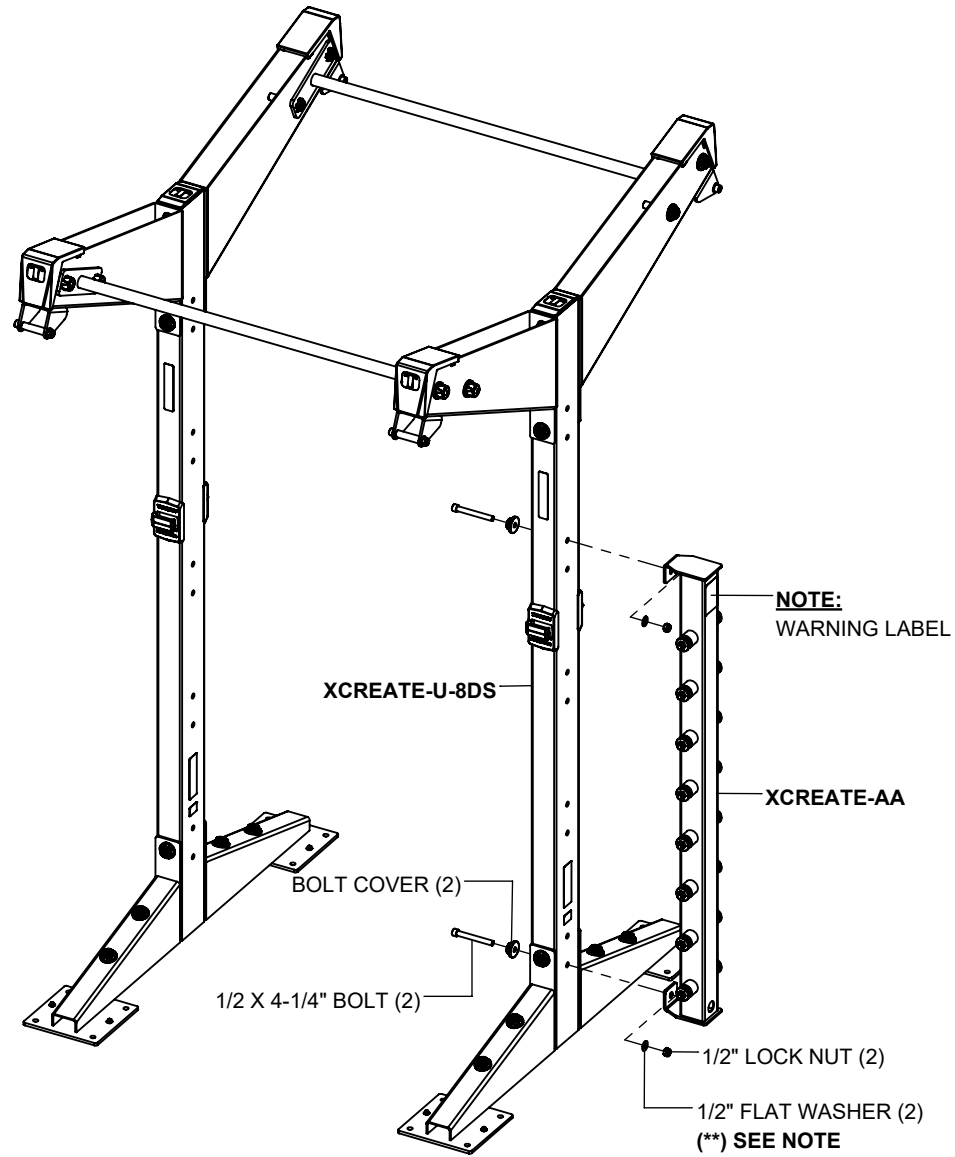

## NOTES:

**SECURELY** tighten all bolt connections in this step.

(\*\*) **HARDWARE COVERS CANNOT** be used on plate side.

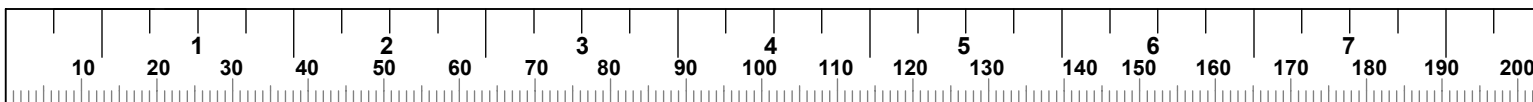

**XCREATE-AAD  
ATTACHMENT ANCHOR DIP**

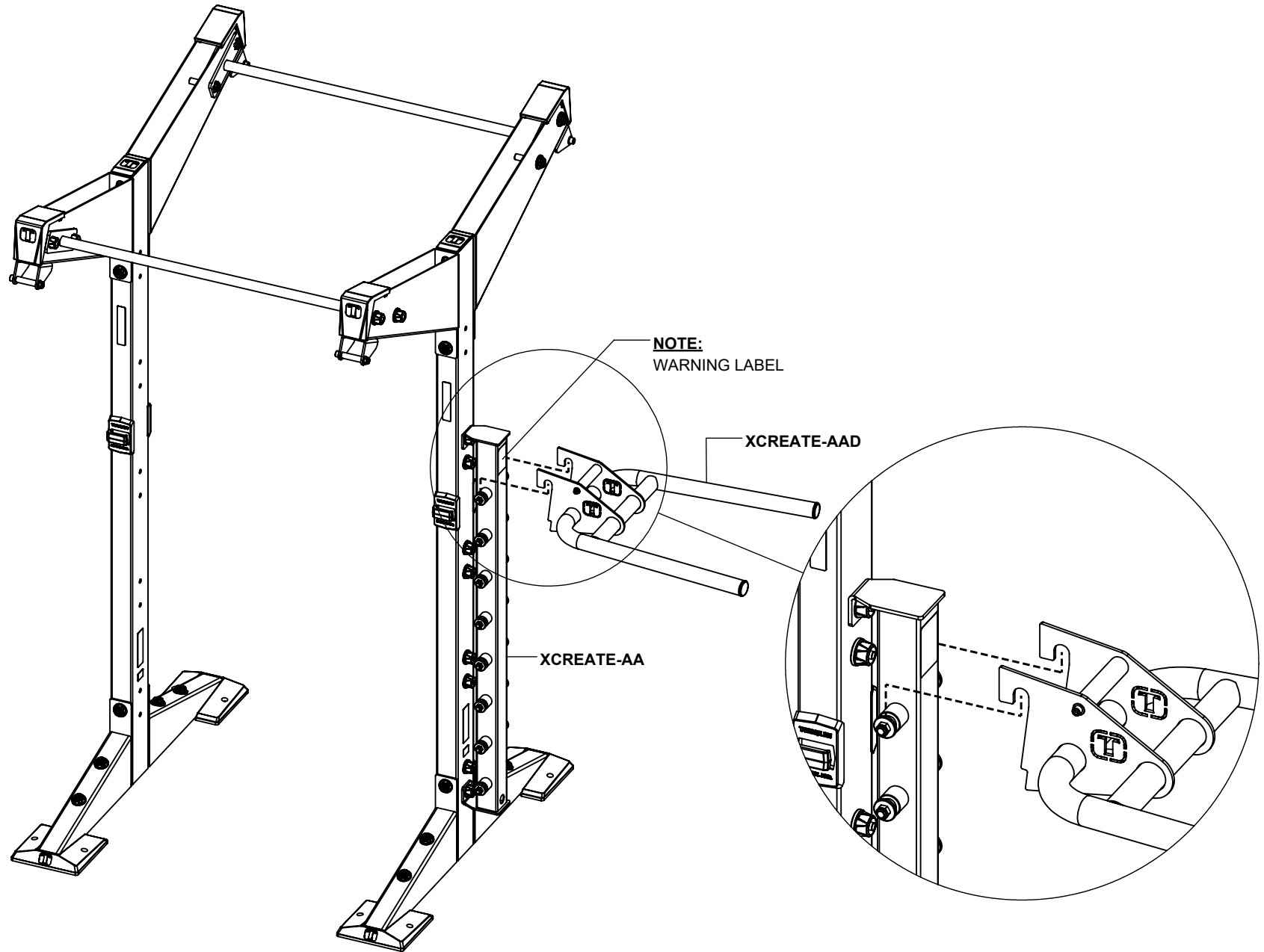

**XCREATE - AAPS  
ATTACHMENT ANCHOR PLYO STEP**

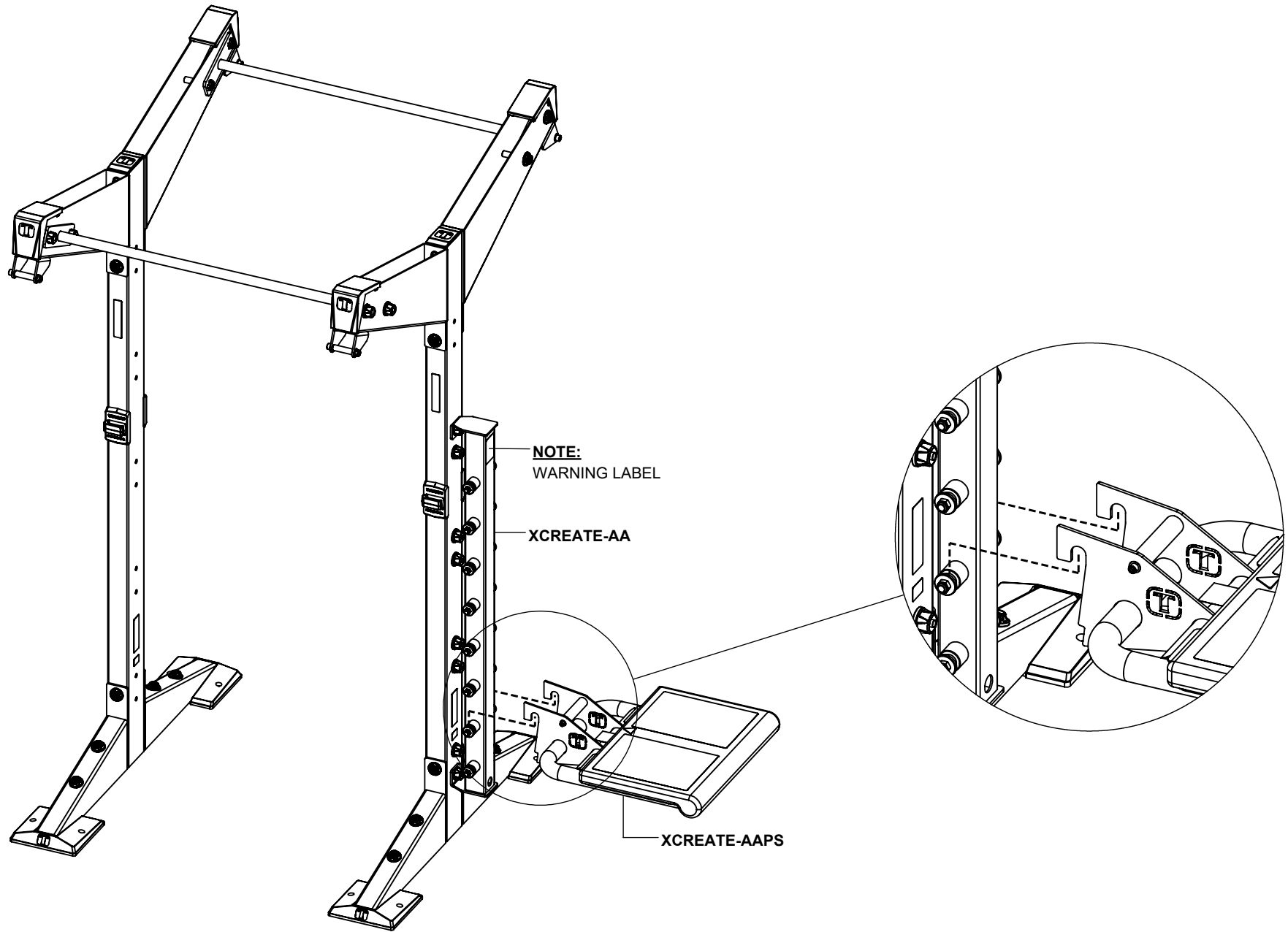

# **XCREATE-AE ATTACHMENT EXTENSION**

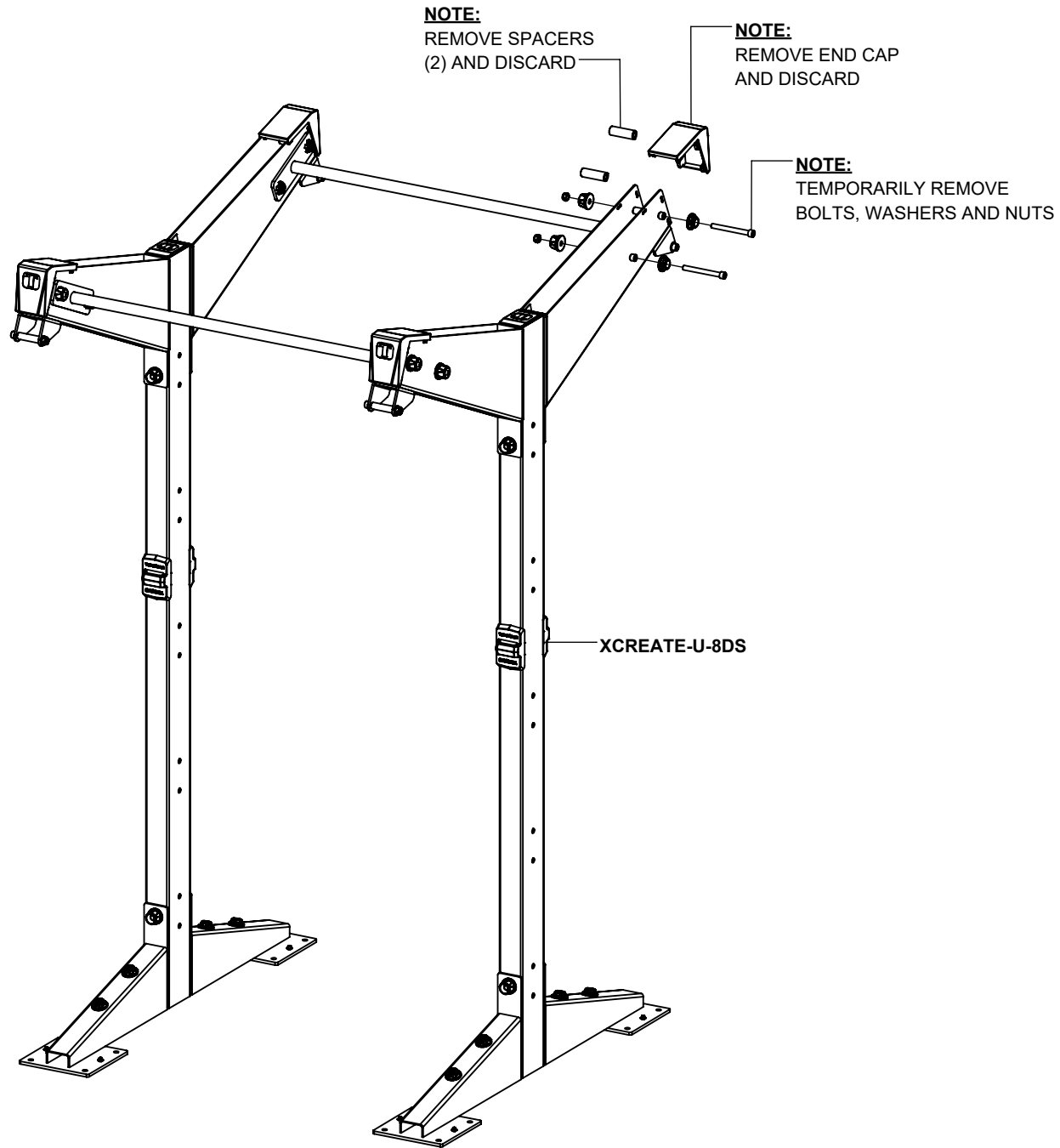

# **XCREATE-AE ATTACHMENT EXTENSION**

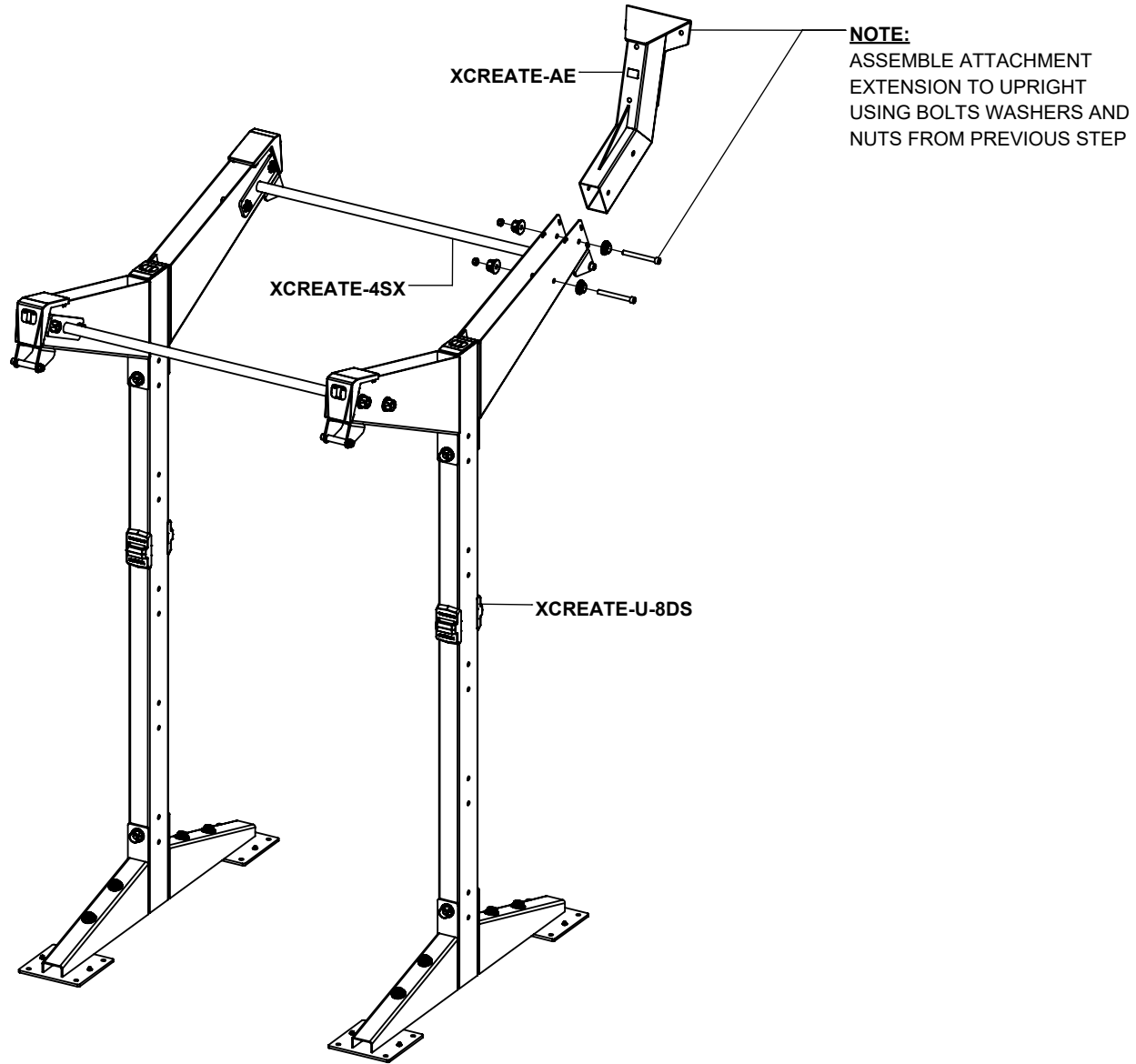

## **NOTES:**

**SECURELY** assemble bolt connections in this step.

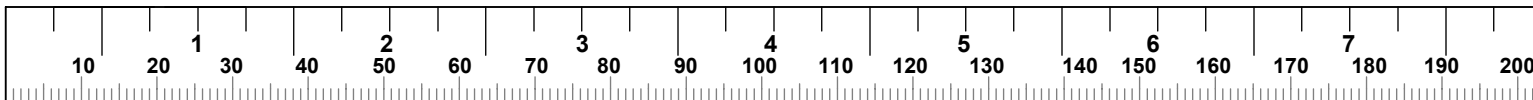

**XCREATE-AE & XCREATE-3DSM  
ATTACHMENT EXTENSION AND  
3 DIMENSIONAL SWIVEL W MOUNT**

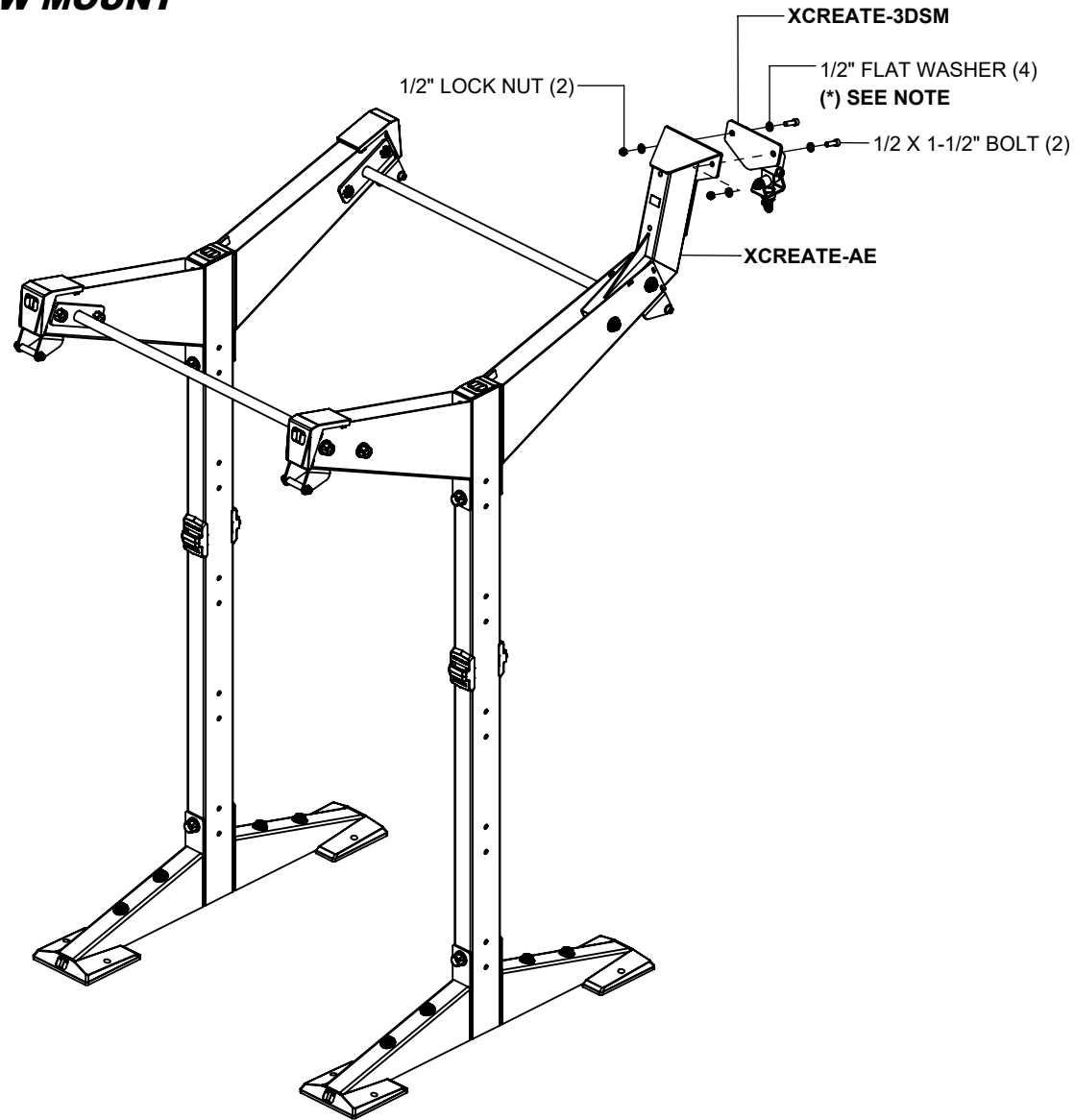

**NOTES:**

**SECURELY** assemble bolt connections in this step.

(\*) **HARDWARE COVERS** **CAN** be used in place of washers in this step. (SEE PAGE 3).

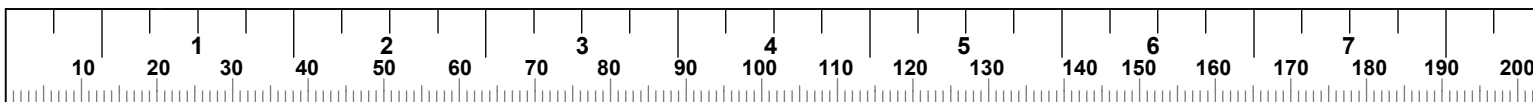

**XERT  
RELENTLESS ROPE TRAINER (UPRIGHT MOUNT)**

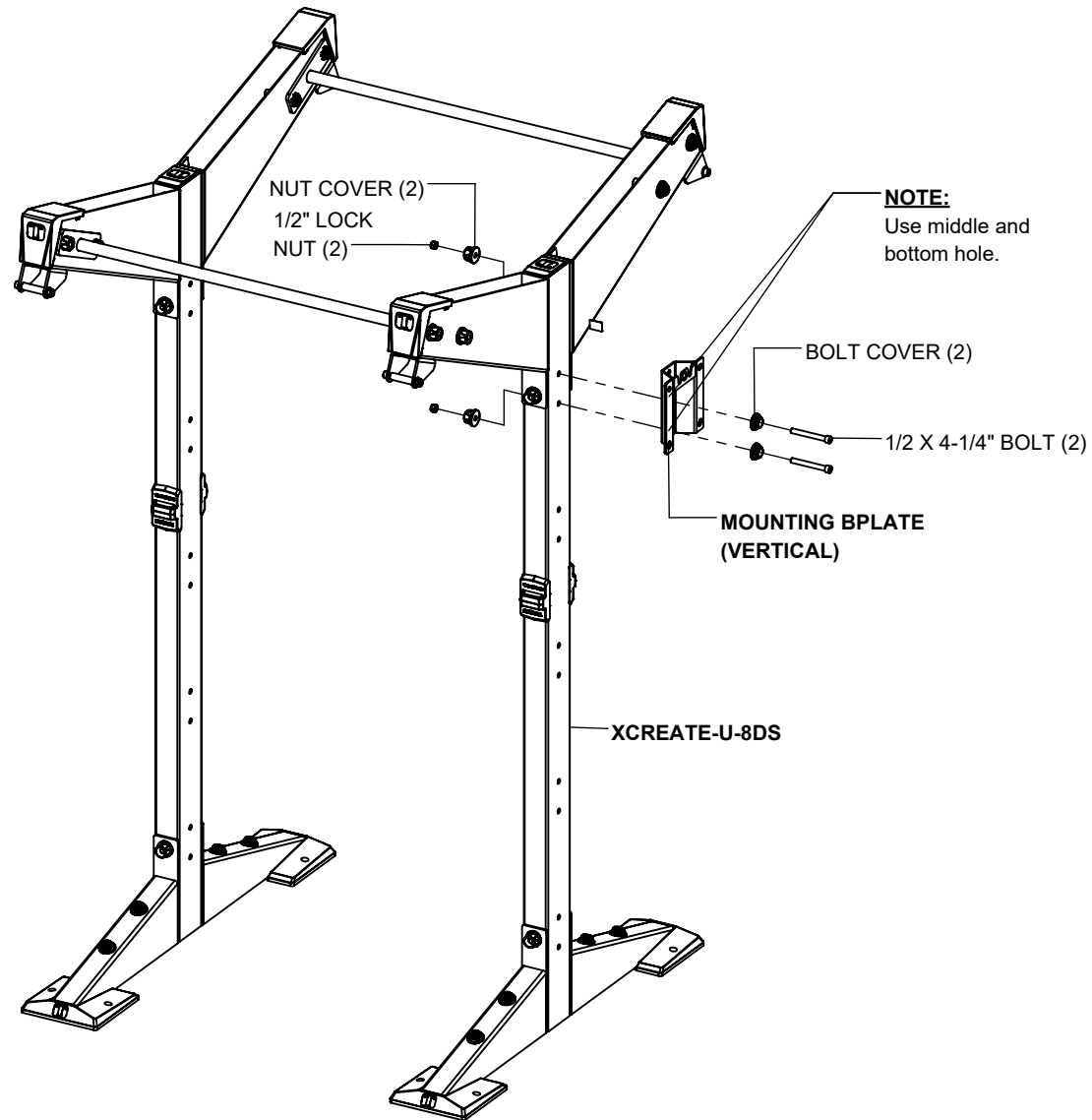

**NOTES:**

**SECURELY** tighten all bolt connections in this step.

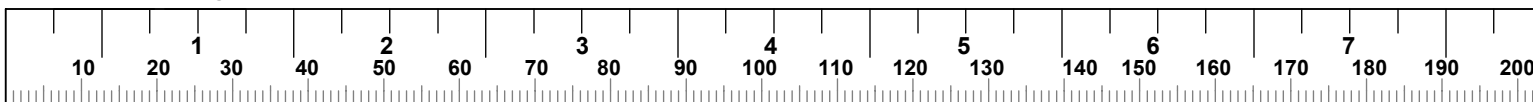

# **XERT RELENTLESS ROPE TRAINER (UPRIGHT MOUNT)**

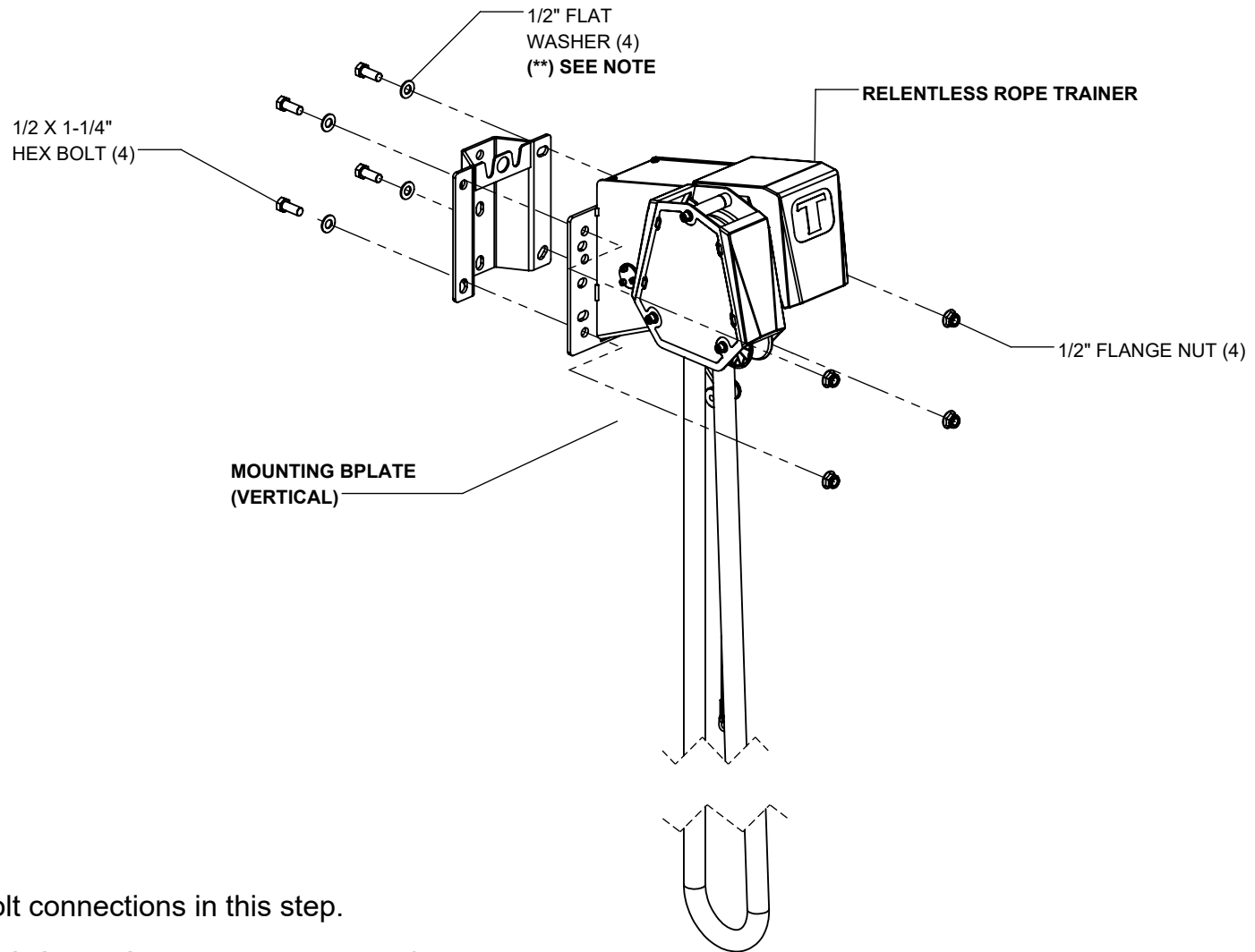

## **NOTES:**

**SECURELY** tighten all bolt connections in this step.

(\*\*) **HARDWARE COVERS CANNOT** be used in place of washers in this step.

XCREATE has been hidden for assembly clarity.

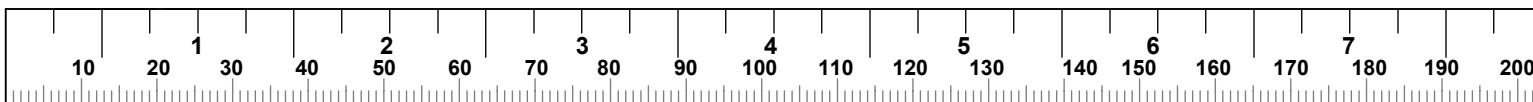

**XCREATE-BM  
BOOM MOUNT**

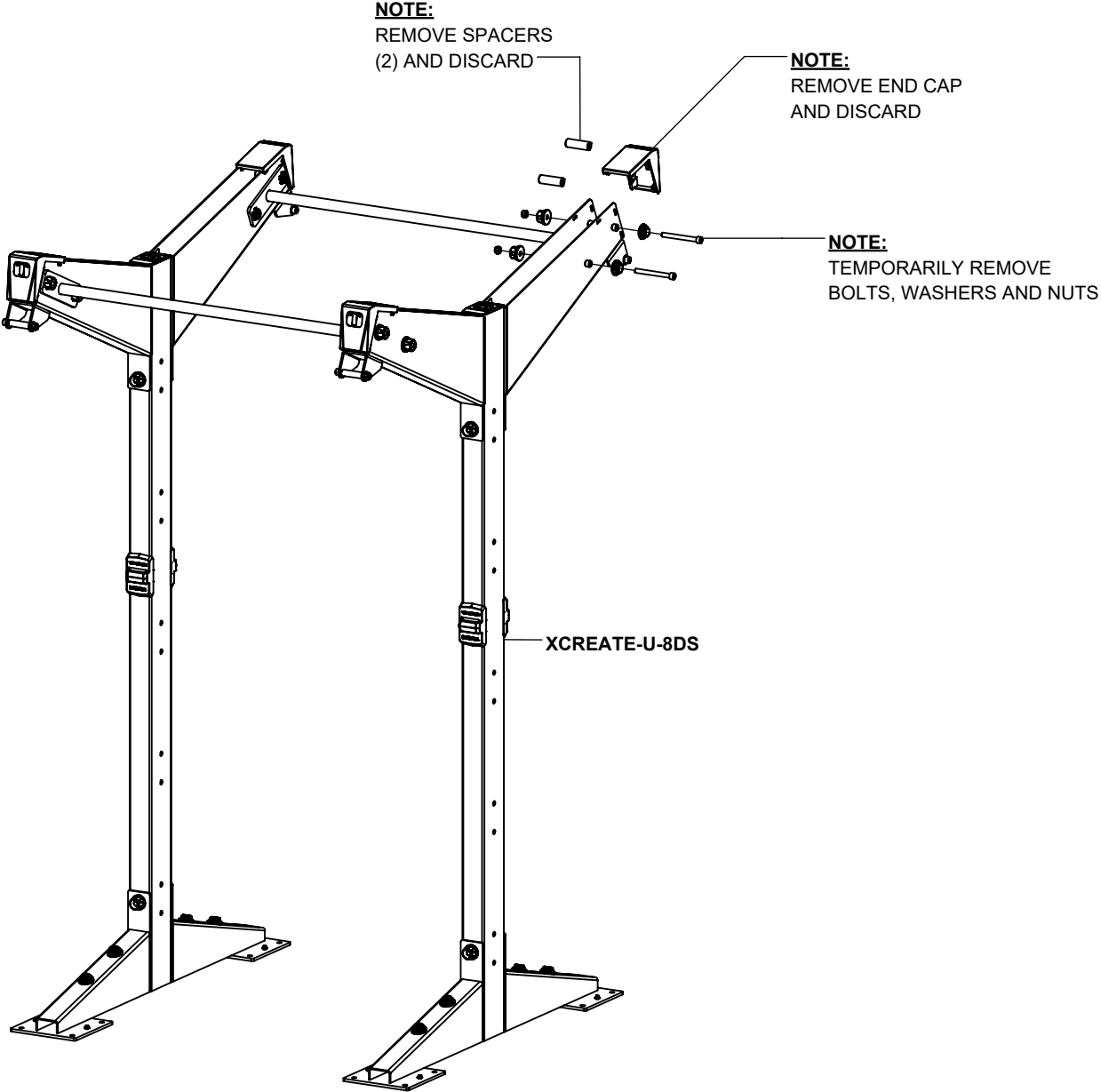

## XCREATE-BMXERT BOOM MOUNT

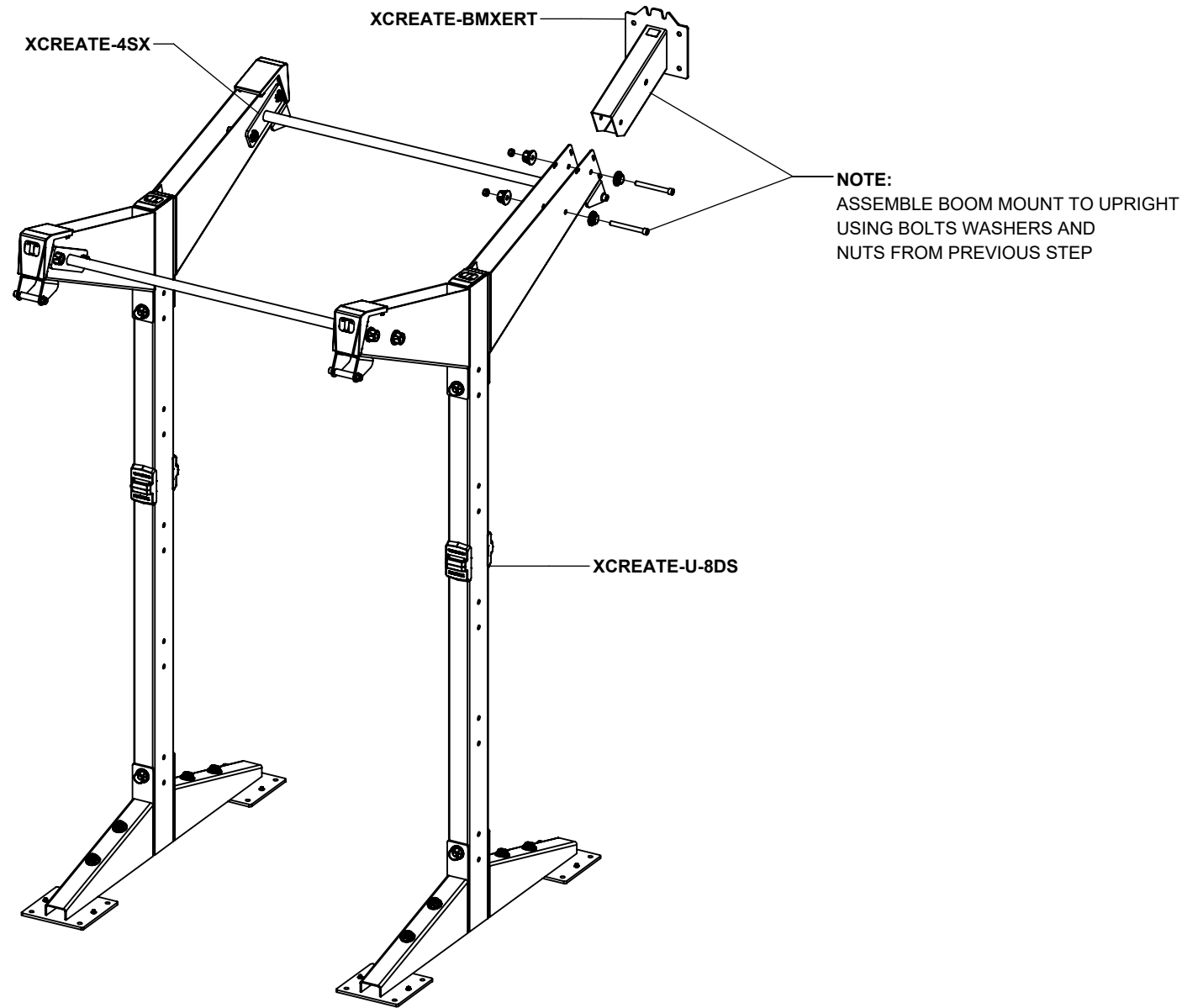

### NOTE:

**SECURELY** tighten all bolt connections in this step.

# XCREATE-BMXERT RELENTLESS ROPE TRAINER / RELENTLESS RIPPER

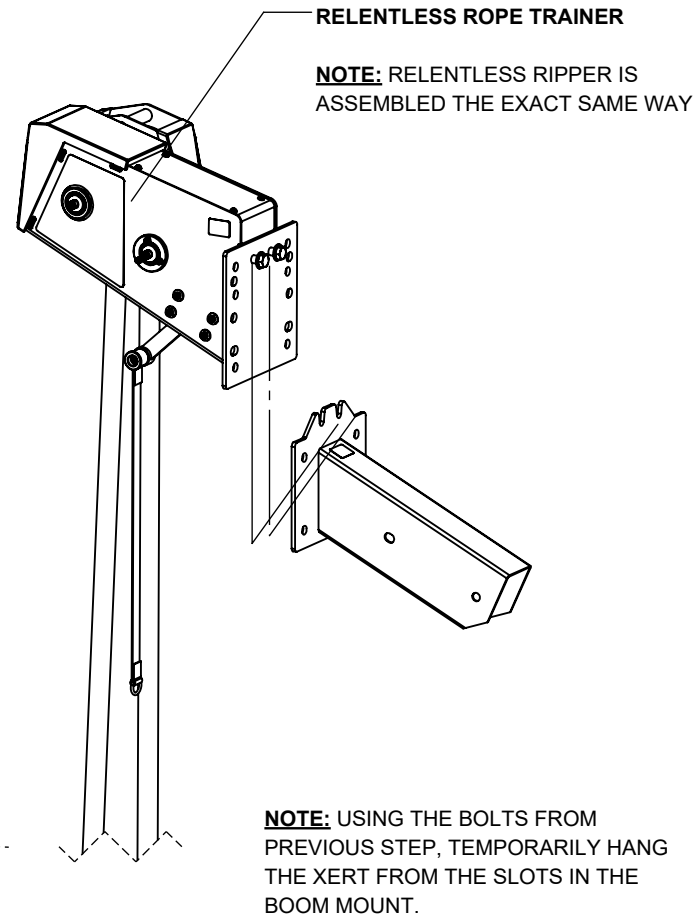
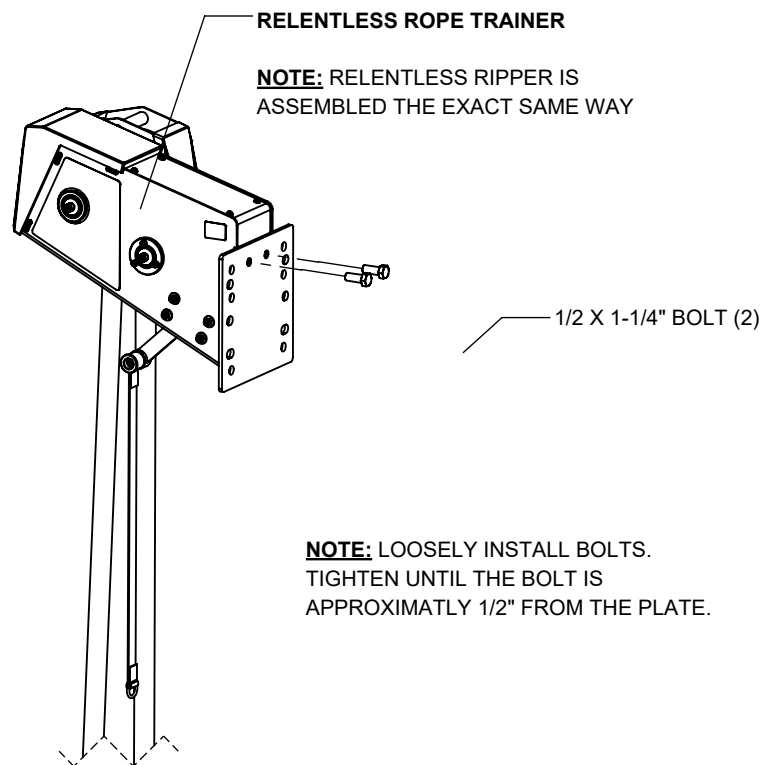

## **NOTE:**

The **Relentless Rope Trainer** is shown, follow the exact same steps to assemble the **Relentless Ripper**.

(\*\*) **HARDWARE COVERS** **CANNOT** be used in place of washers in this step.

XCREATE has been hidden for assembly clarity.

# XCREATE-BMXERT RELENTLESS ROPE TRAINER / RELENTLESS RIPPER

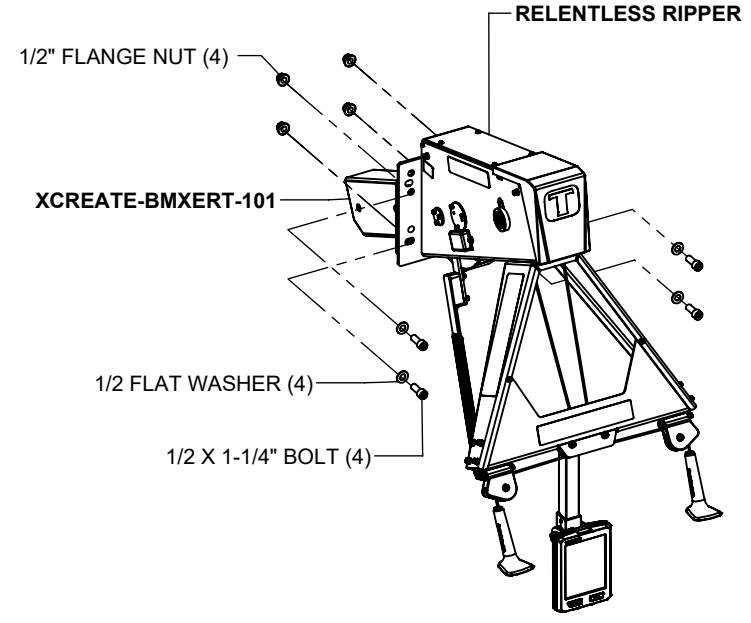
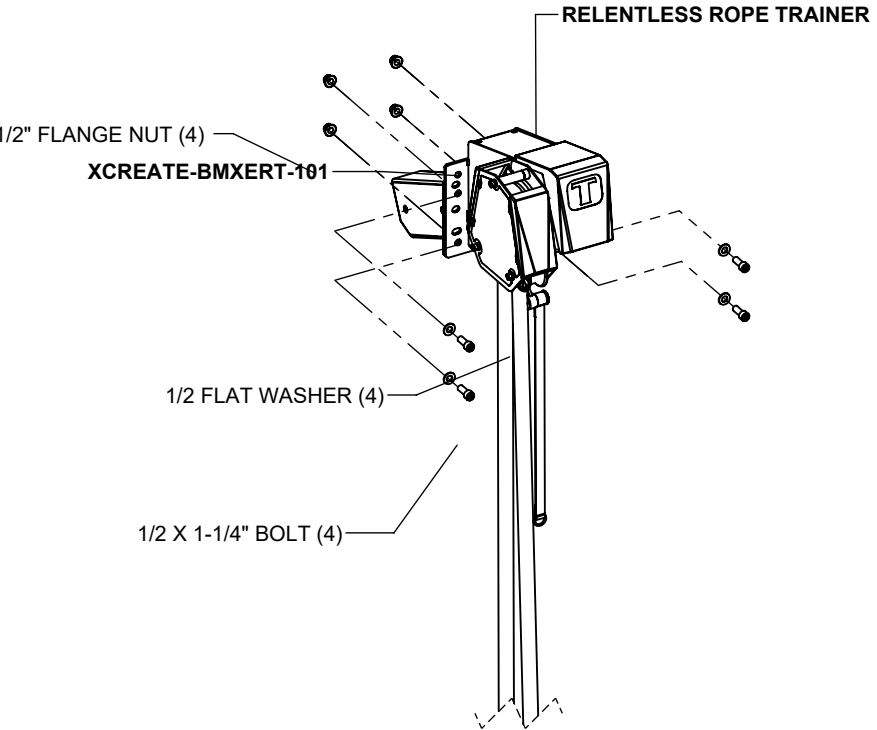

**NOTE:**

**SECURELY** tighten all bolt connections in this step, Including the bolts from the previous step.

(\*\*) **HARDWARE COVERS CANNOT** be used in place of washers in this step.

**XCREATE** has been hidden for assembly clarity.

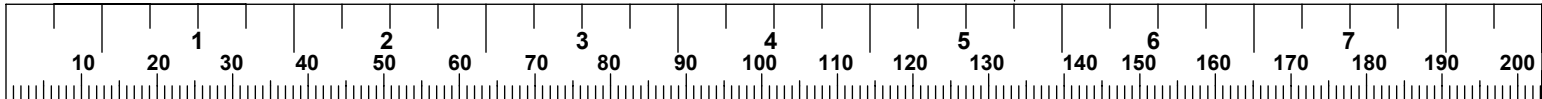

# XCREATE-SAM XCREATE SIDE ATTACHMENT MOUNT

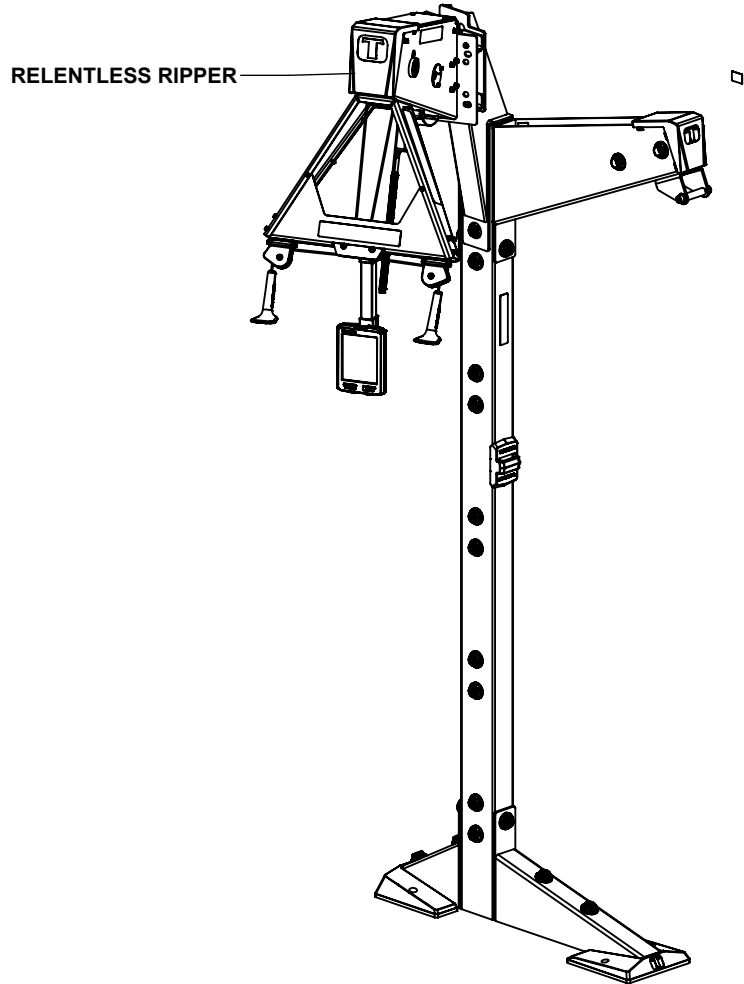

RELENTLESS RIPPER

XCREATE-SAM  
SIDE ATTACHMENT MOUNT

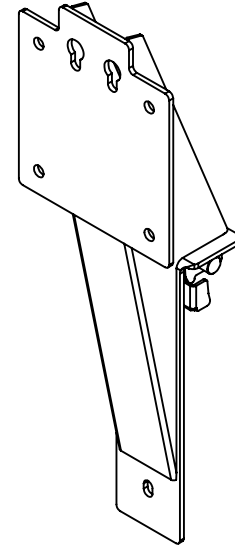

XCREATE-SUW  
SINGLE UNIT WEDGE

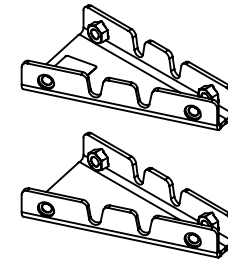

XCREATE-DUW  
DOUBLE UNIT WEDGE

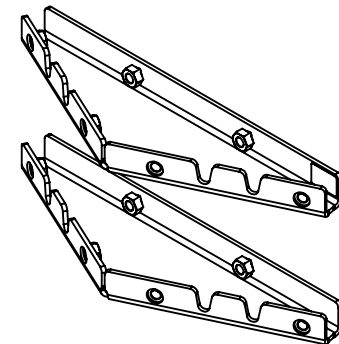

## NOTE:

The **Relentless Ripper** is shown, **Relentless Rope** may be assembled the same way.

Assembly instructions for the attachments above are included with the **XCREATE-SAM**.

The instructions can also be downloaded at <https://commercial.torquefitness.com/pages/assembly-manuals>

**XCREATE-6RX  
RELENTLESS ROPE TRAINER / RELENTLESS RIPPER**

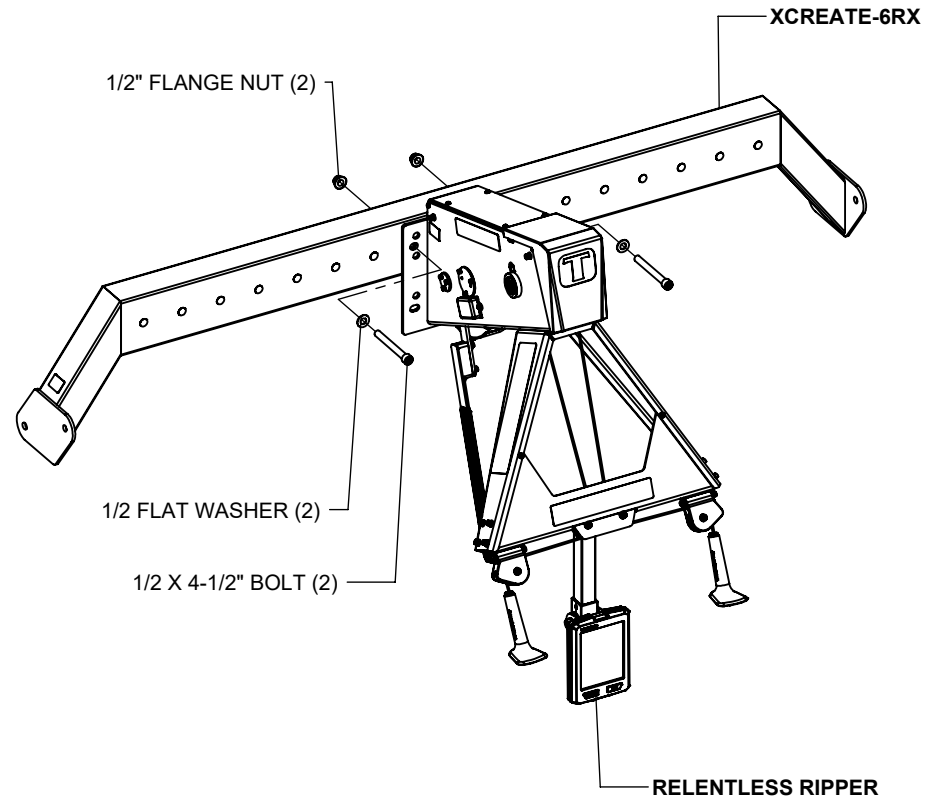
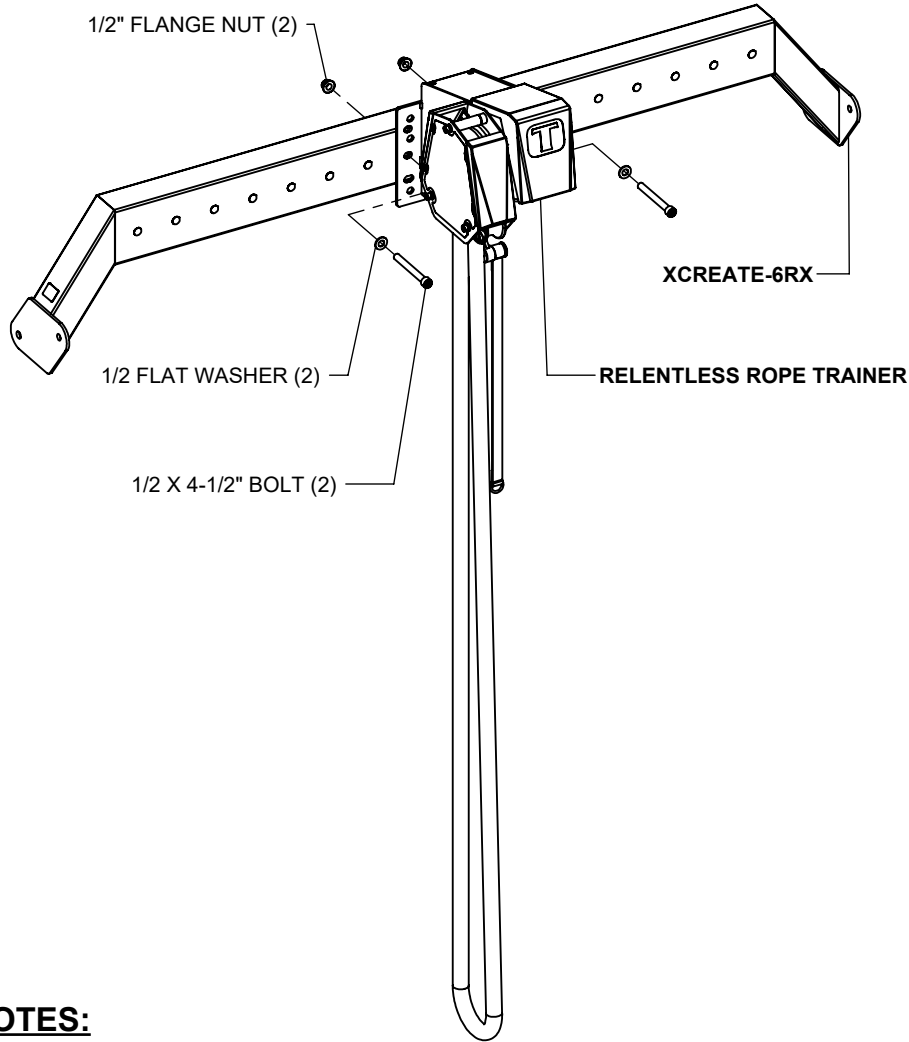

**NOTES:**

**SECURELY** tighten all bolt connections in this step.

(\*\*) **HARDWARE COVERS CANNOT** be used in place of washers in this step.

**XCREATE** uprights have been hidden for assembly clarity

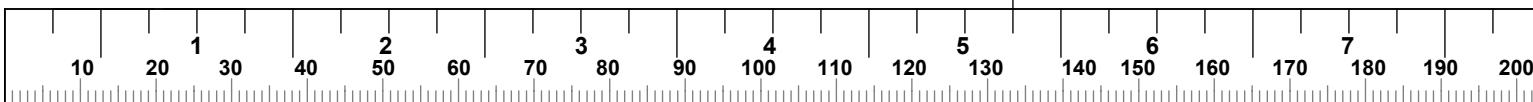

**XCREATE-6RX  
BRIDGE BALL TARGET / ROCK CLIMBING KIT**

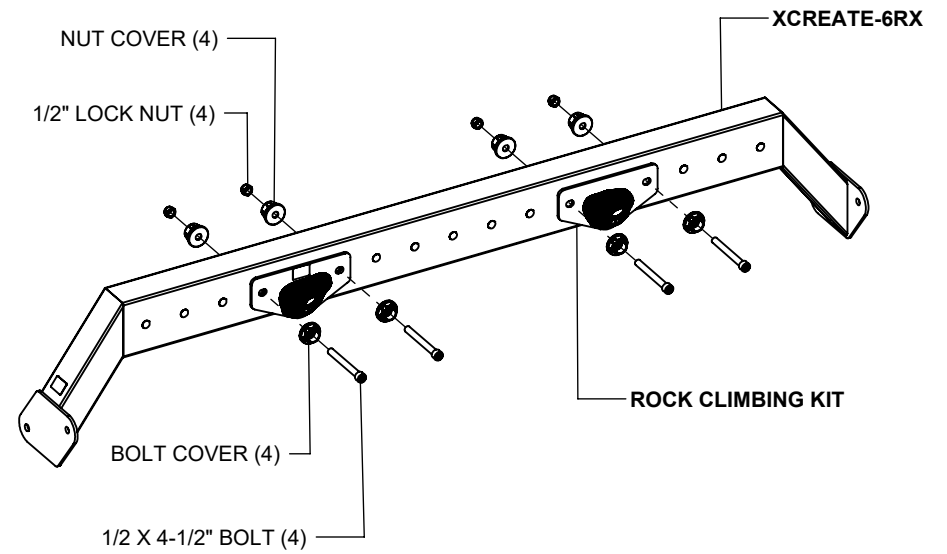
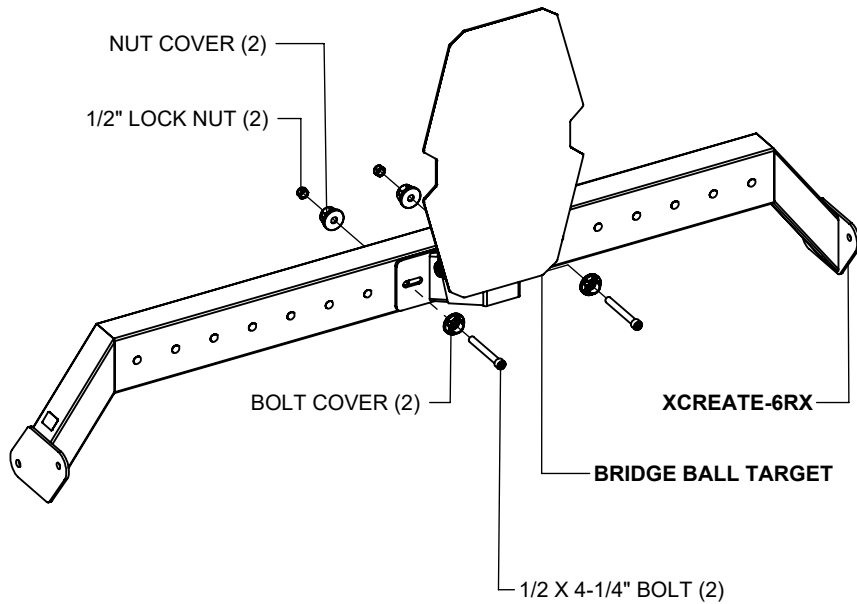

**NOTES:**

**SECURELY** tighten all bolt connections in this step.

XCREATE uprights have been hidden for assembly clarity

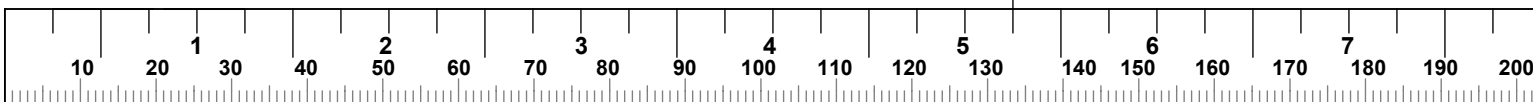

**XCREATE-SA-BOSU  
BOSU STORAGE ATTACHMENT**

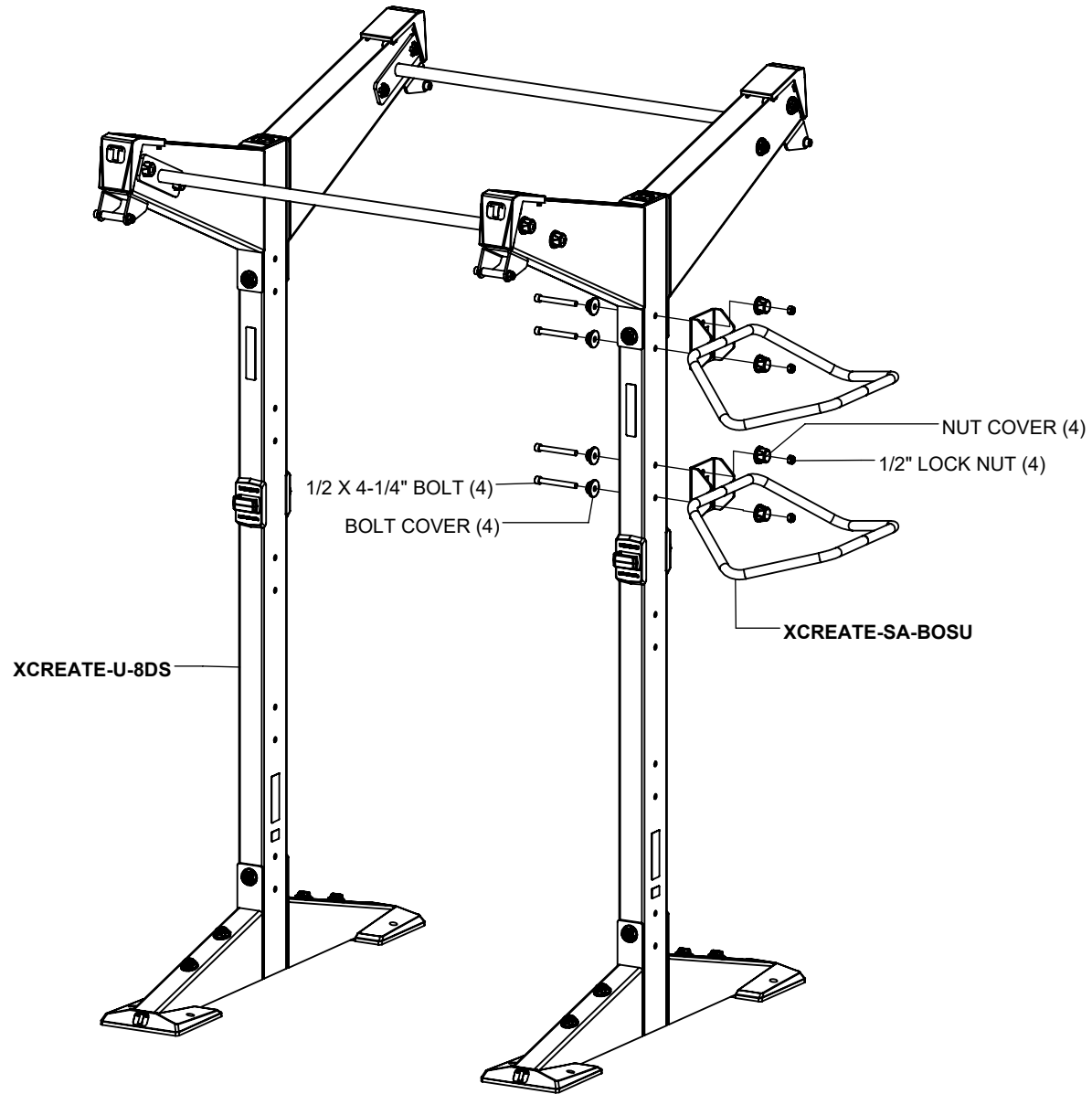

**NOTES:**

**SECURELY** tighten all bolt connections in this step.

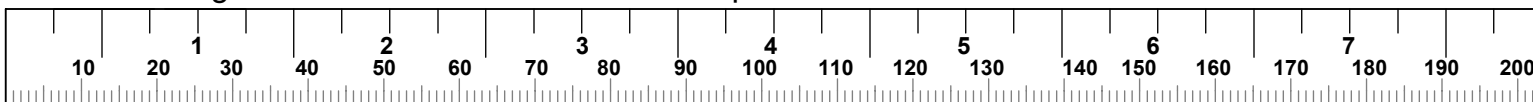

**XCREATE-FRS6-8  
FOAM ROLLER STORAGE ATTACHMENT**

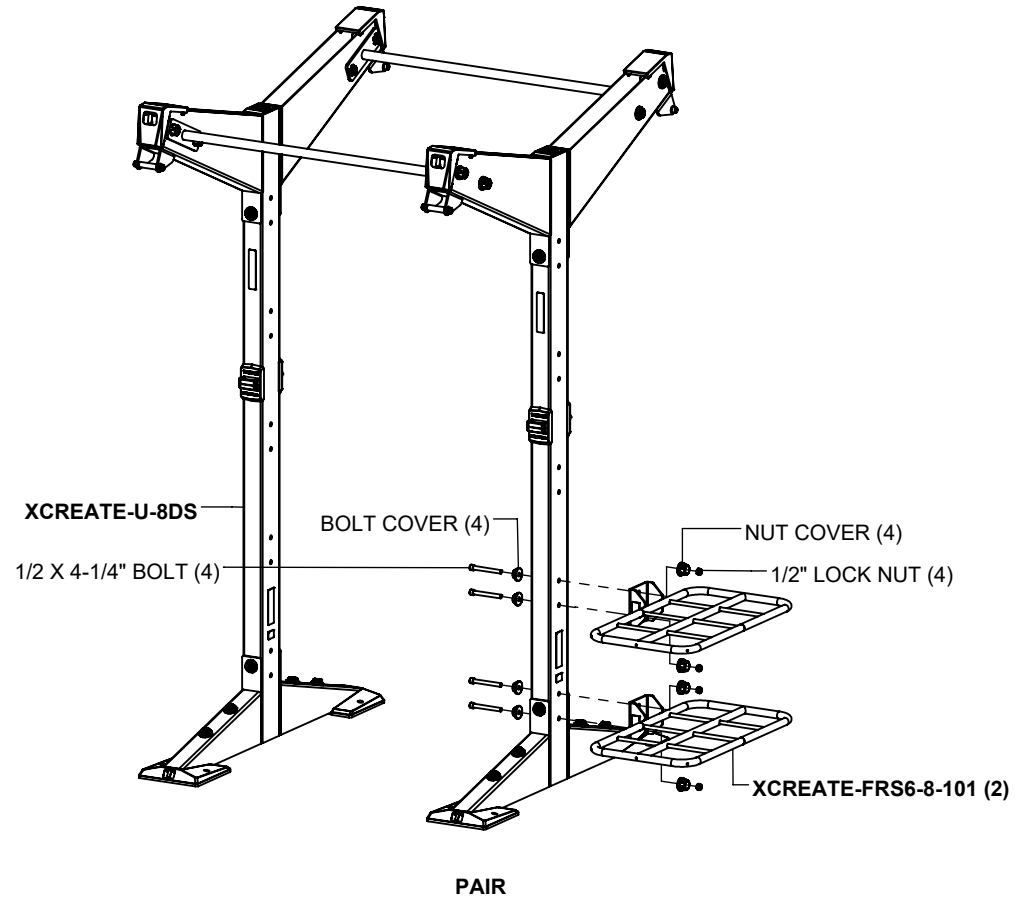
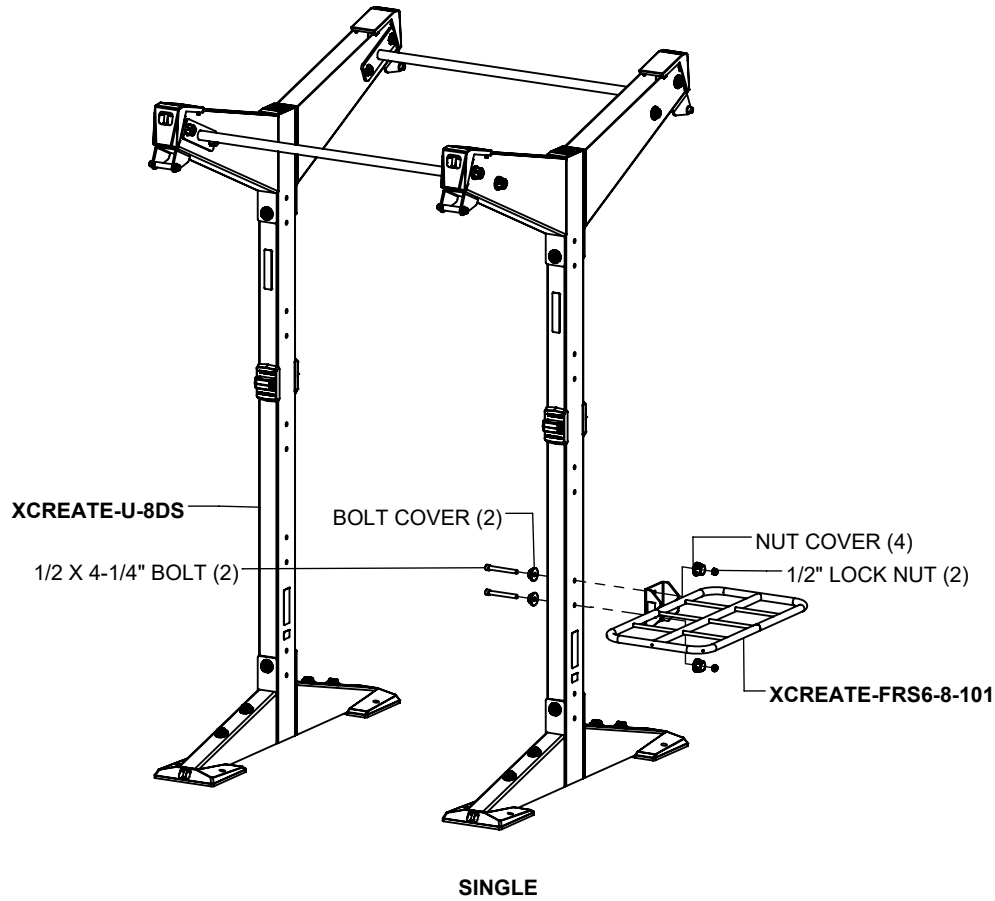

**NOTES:**

Assembly steps show a single and pair. For additional foam roller stability a pair is recommended.

**LEVEL ATTACHMENT AND SECURELY** tighten all bolt connections in this step.

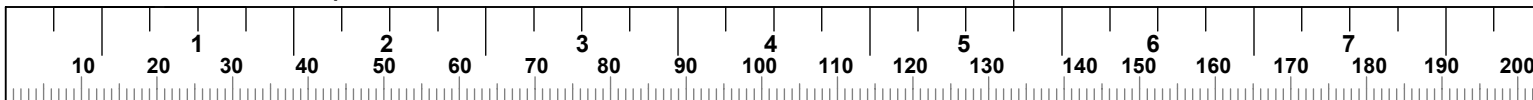

# XCREATE-FRS6-8 FOAM ROLLER STORAGE ATTACHMENT

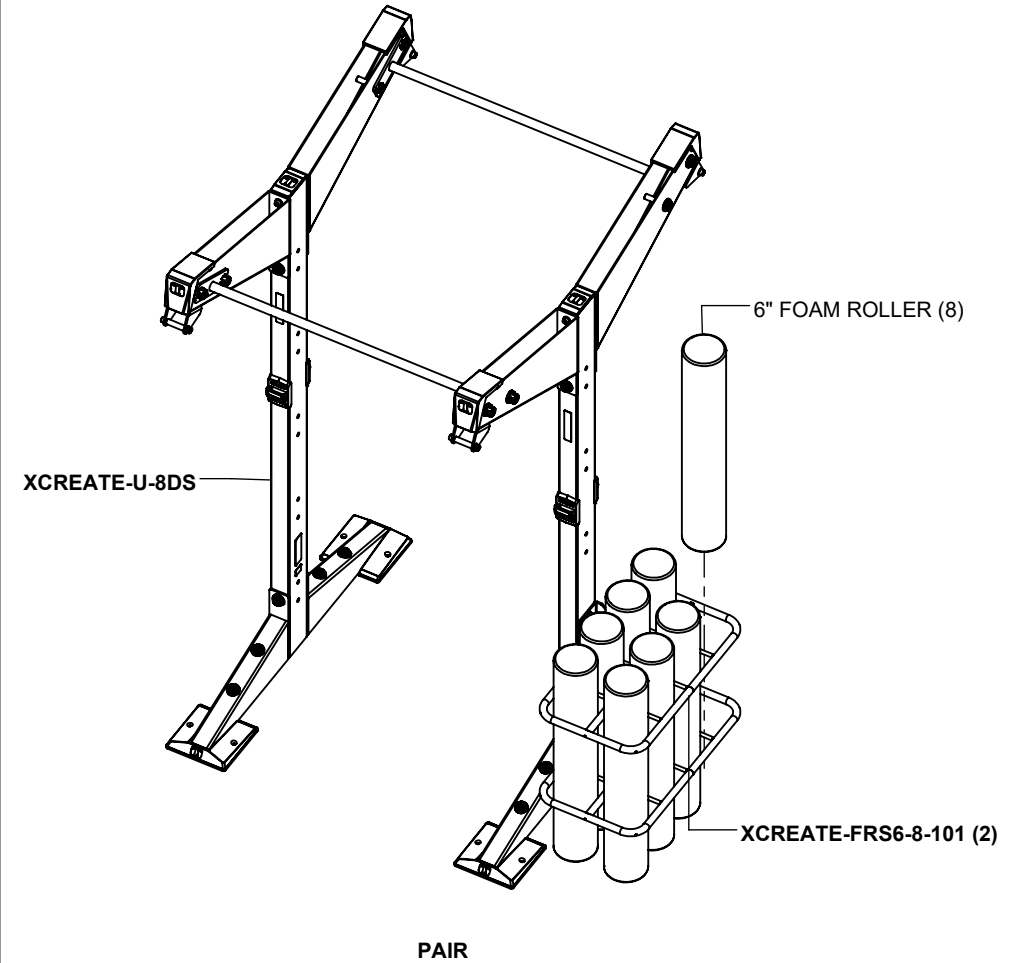
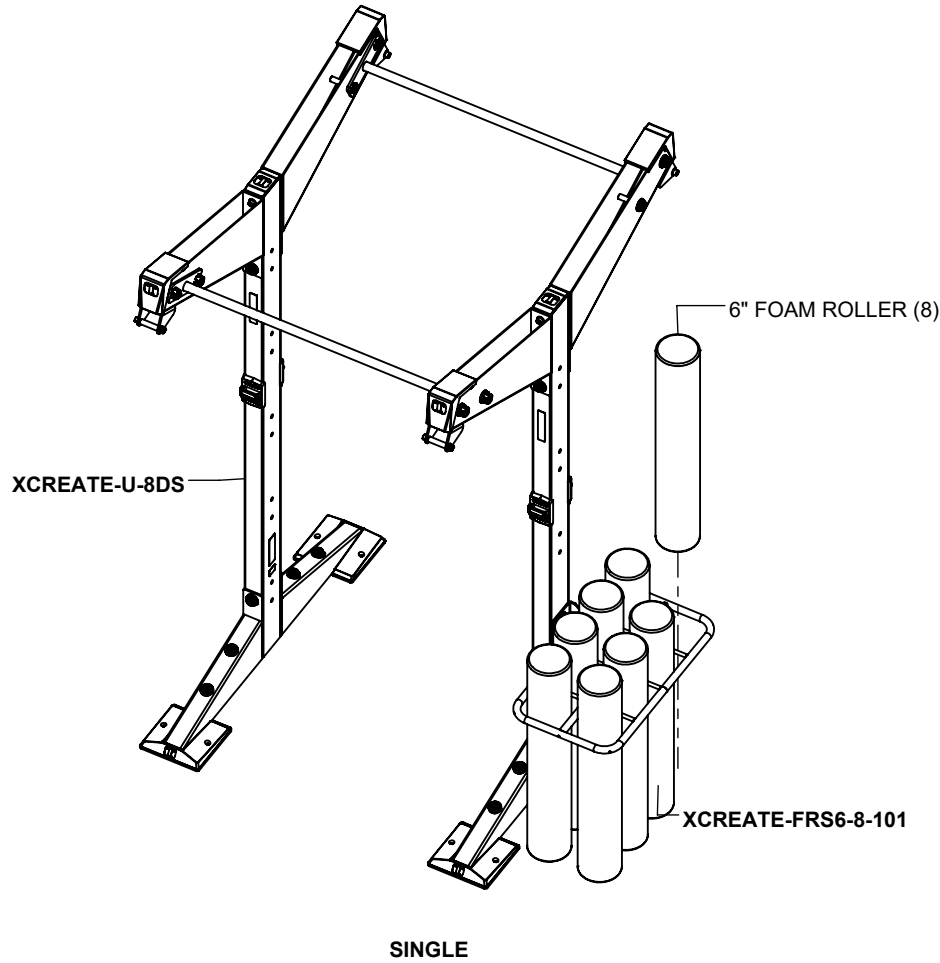

## NOTES:

Assembly steps show a single and pair. For additional foam roller stability a pair is recommended.

**LEVEL ATTACHMENT AND SECURELY** tighten all bolt connections in this step.

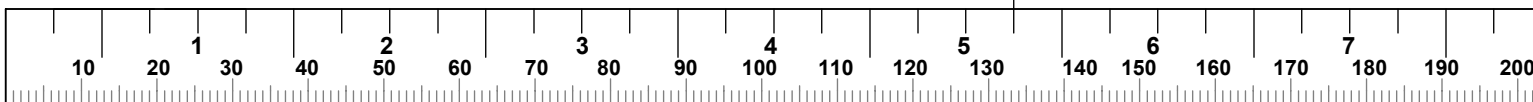

**XCREATE-SBDA  
STALL BAR DIP ATTACHMENT**

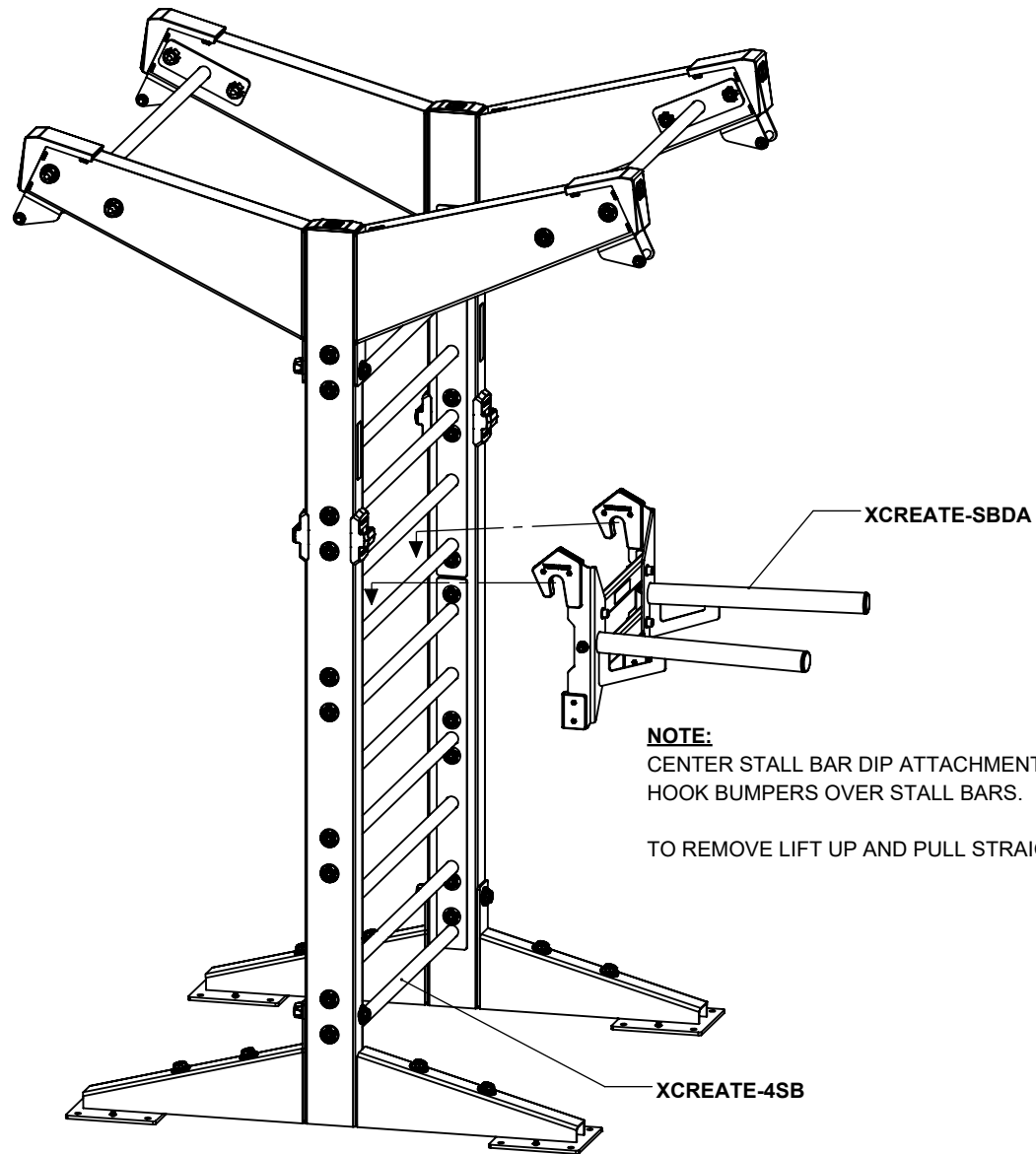

**NOTES:**

The XCREATE 4' stall bar module is required in this step. For module assembly see previous steps.

**BCSA  
BAR CATCH STORAGE ATTACHMENT**

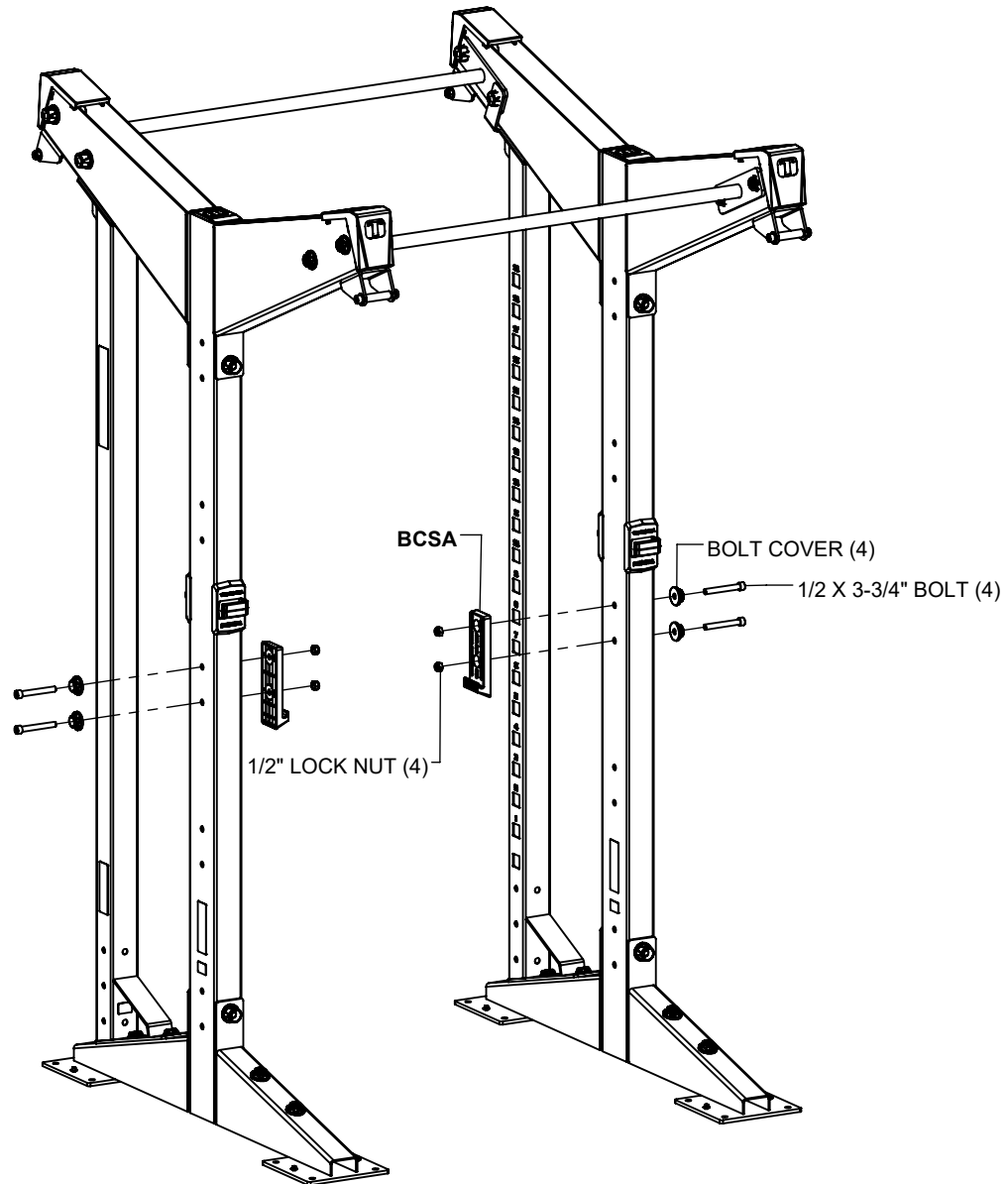

**NOTES:**

**SECURELY** tighten all bolt connections in this step.

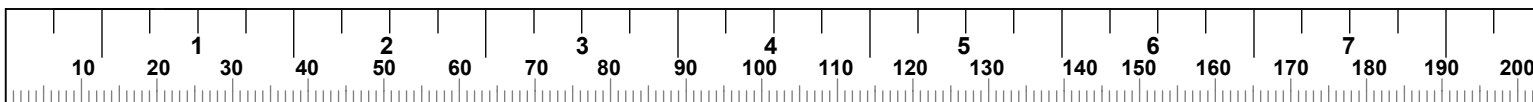

**BCSA  
BAR CATCH STORAGE ATTACHMENT**

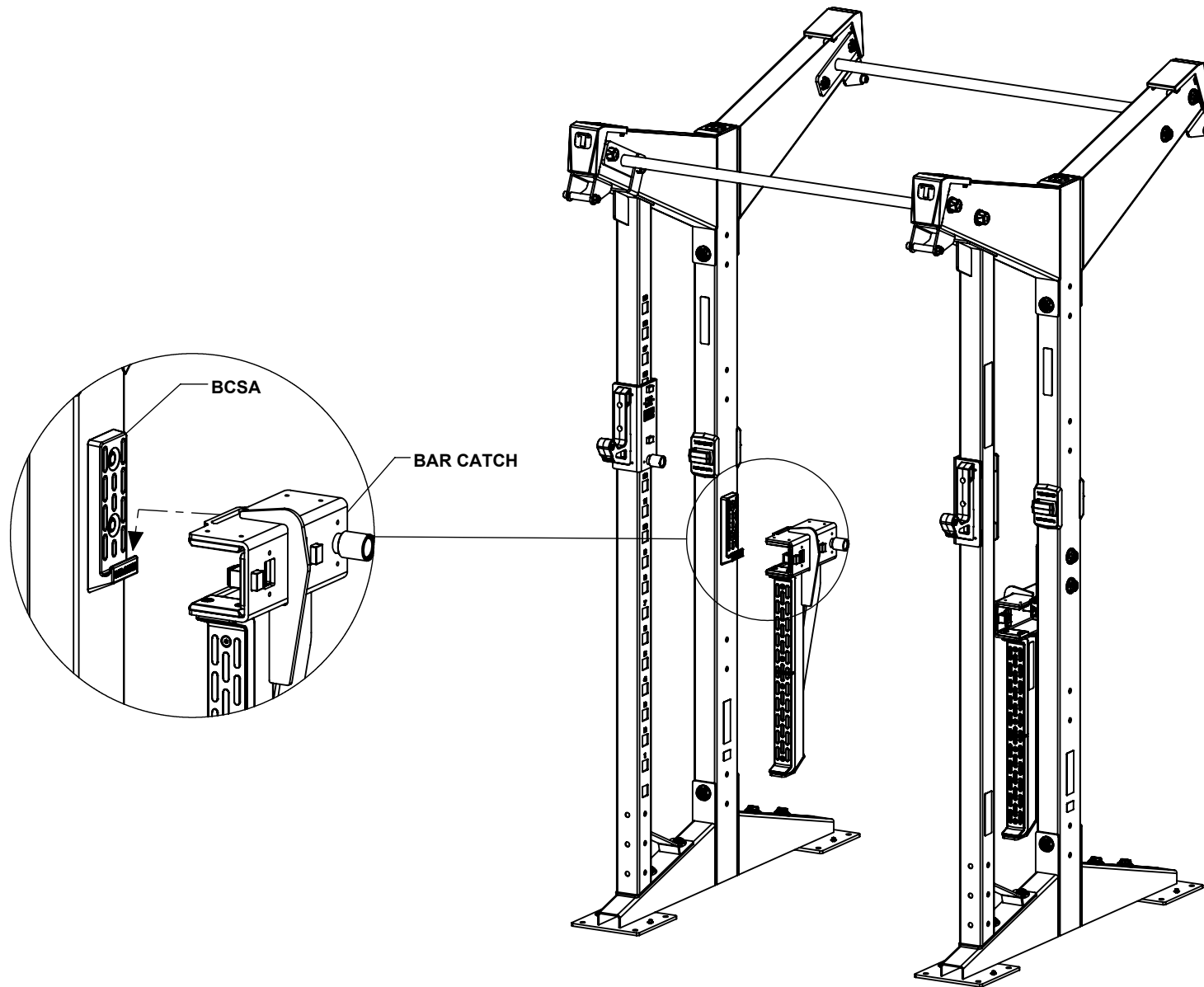

**XCREATE-HMSC  
MAGNETIC SUSPENSION CLIP**

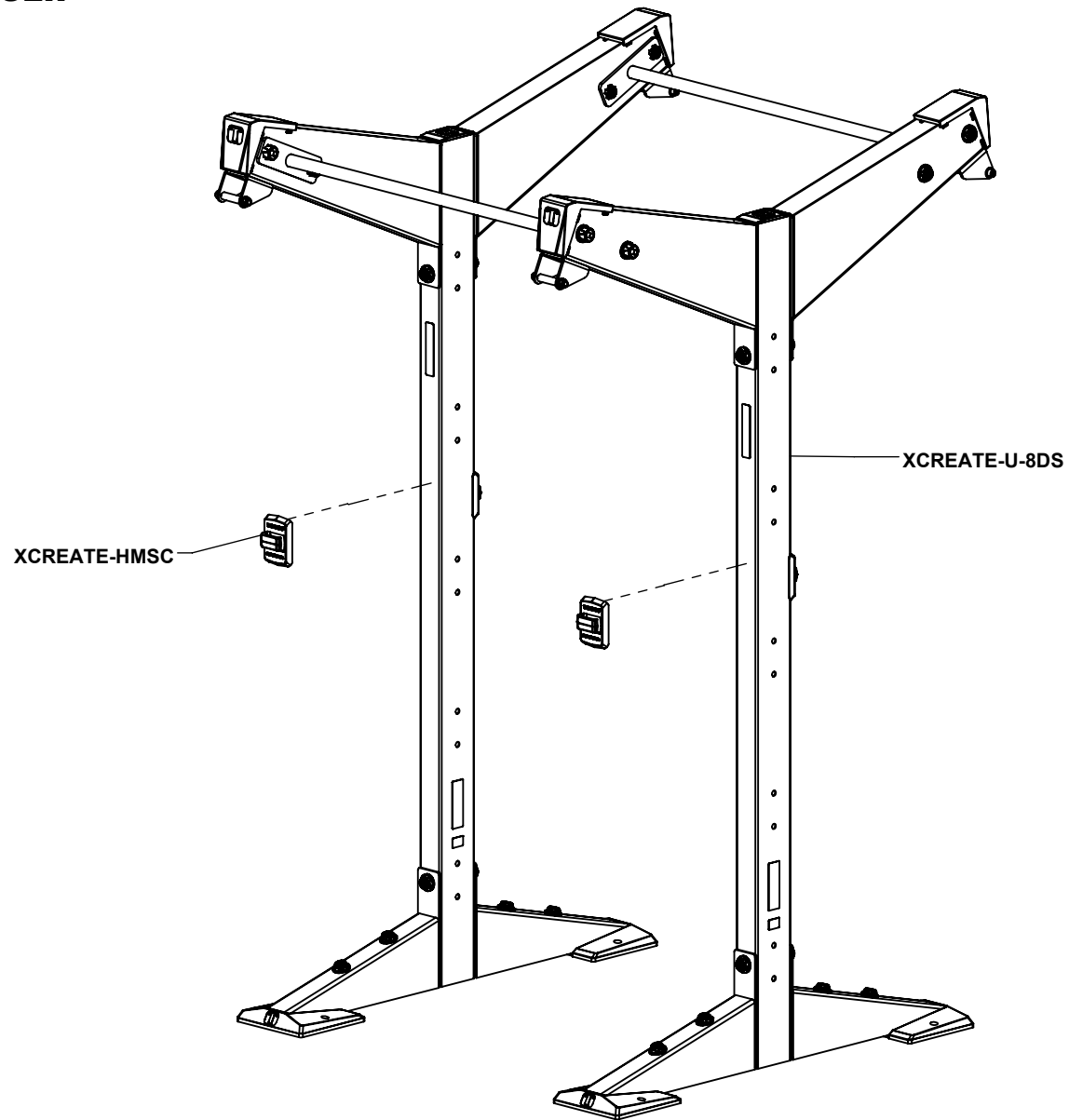

**NOTES:**

Suspension storage clip can be positioned to desired height.

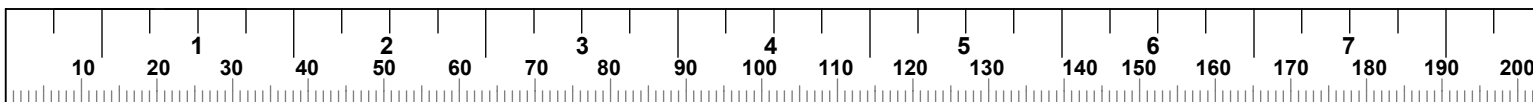

**CPWH  
CHANGE PLATE WEIGHT HORN (QTY 2)**

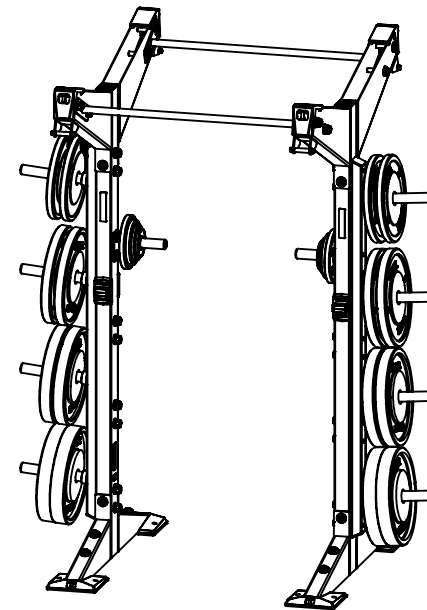
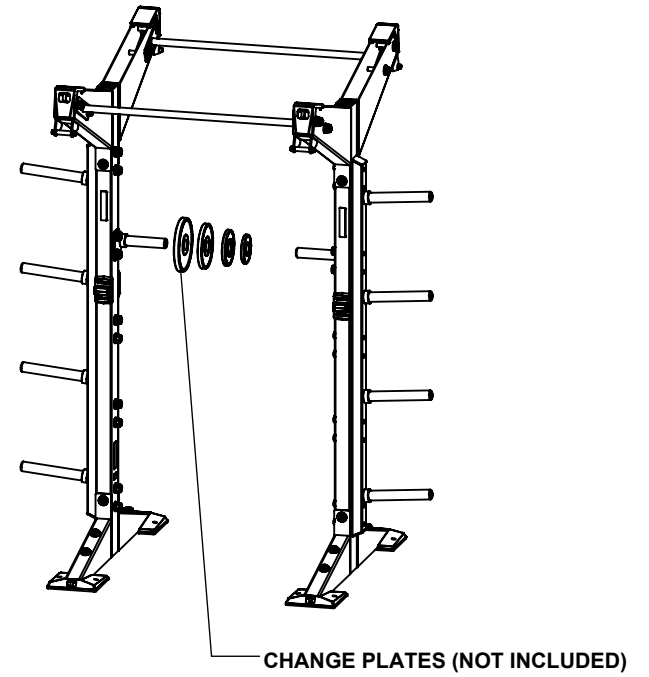
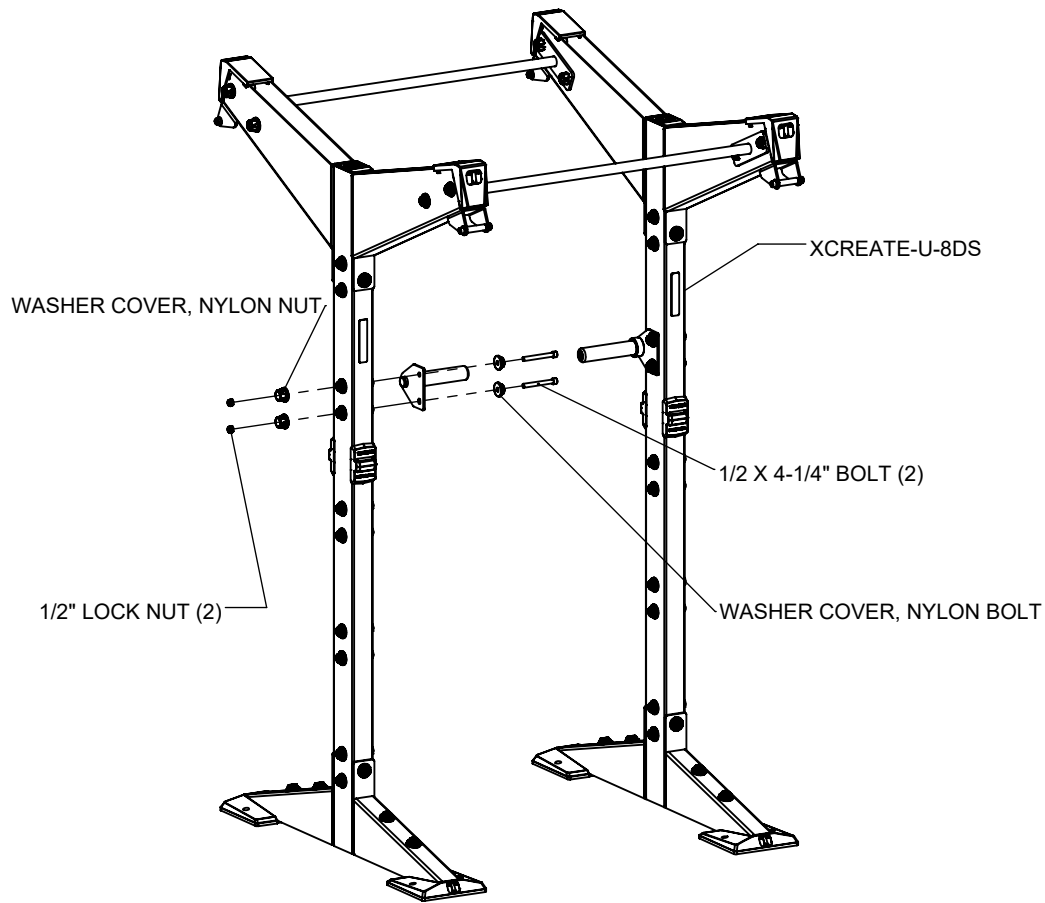

**NOTES:**

**SECURELY** tighten all bolt connections in this step.

(\*) **HARDWARE COVERS CAN** be used in place of washers in this step. (SEE PAGE 3).

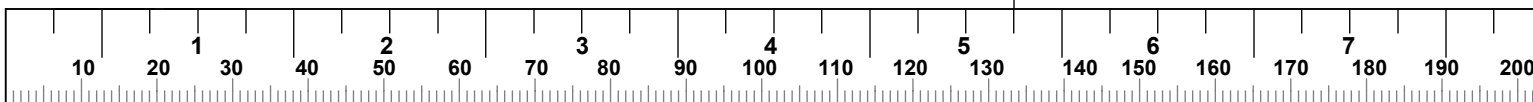

# XCREATE-GRT / XCREATE-TP

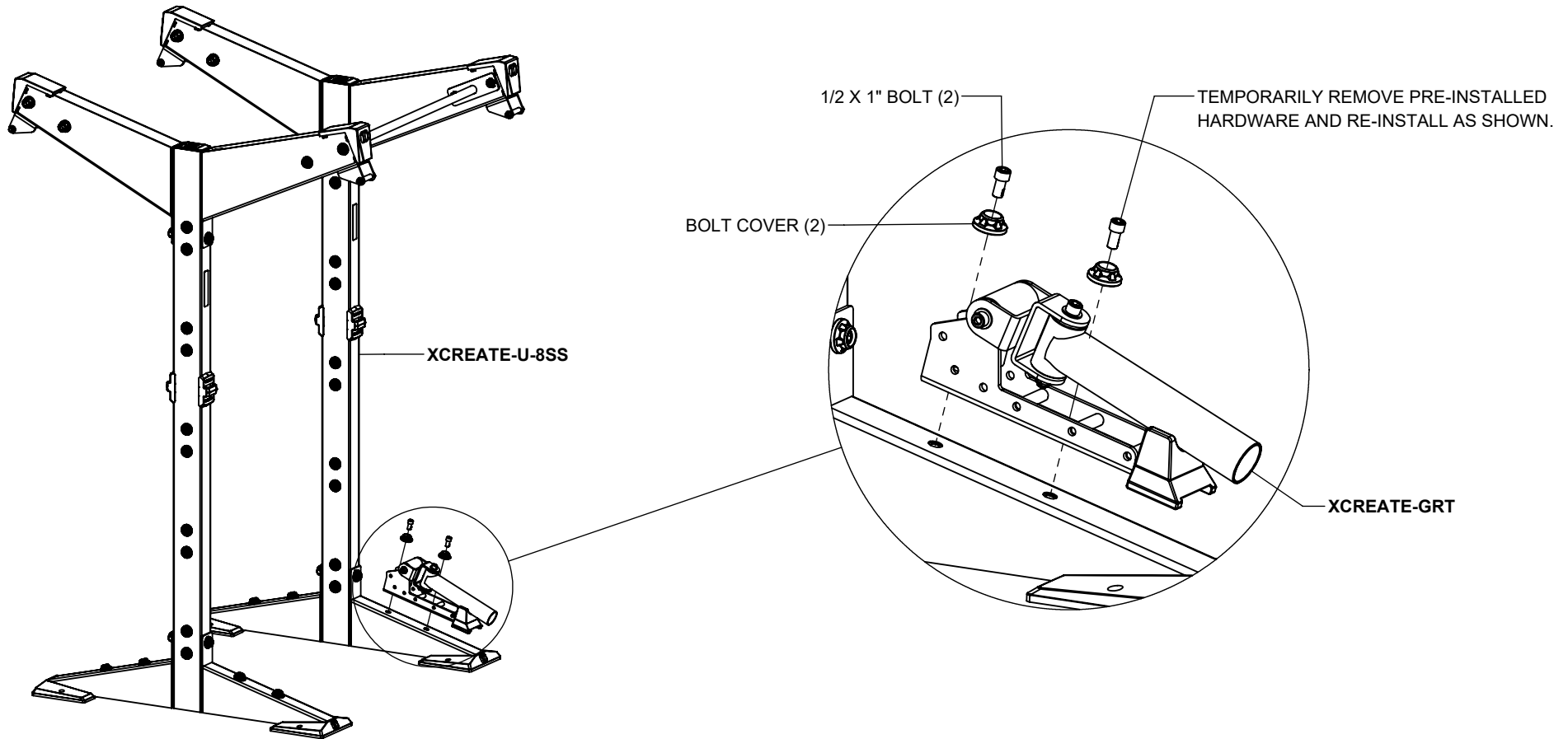

## NOTES:

If more modules will be assembled, do not tighten bolts at this time.  
If this is the only module being assembled, then **SECURELY** tighten all bolts in this step and previous steps.

The **XCREATE-U-7SS** is assembled the exact same way.

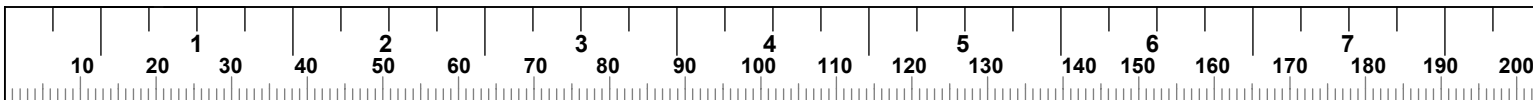

# XCREATE-GRTPS / XCREATE-TP

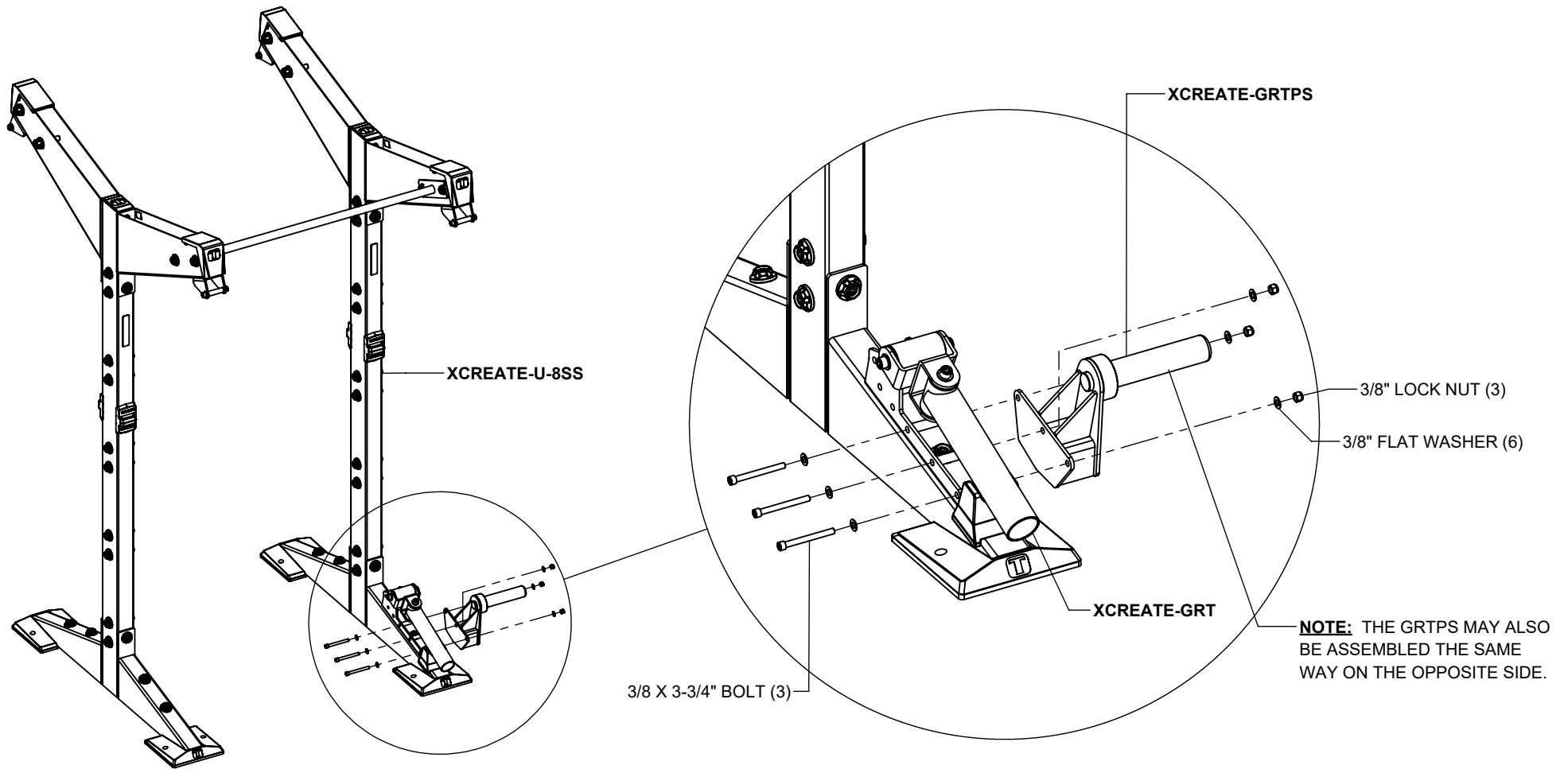

## NOTES:

The XCREATE-U-7SS is assembled the exact same way.

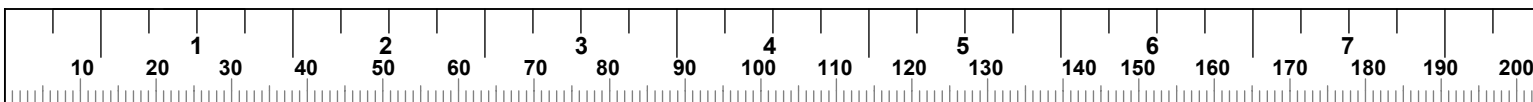

**XCREATE-GRTBS / XCREATE-TP**

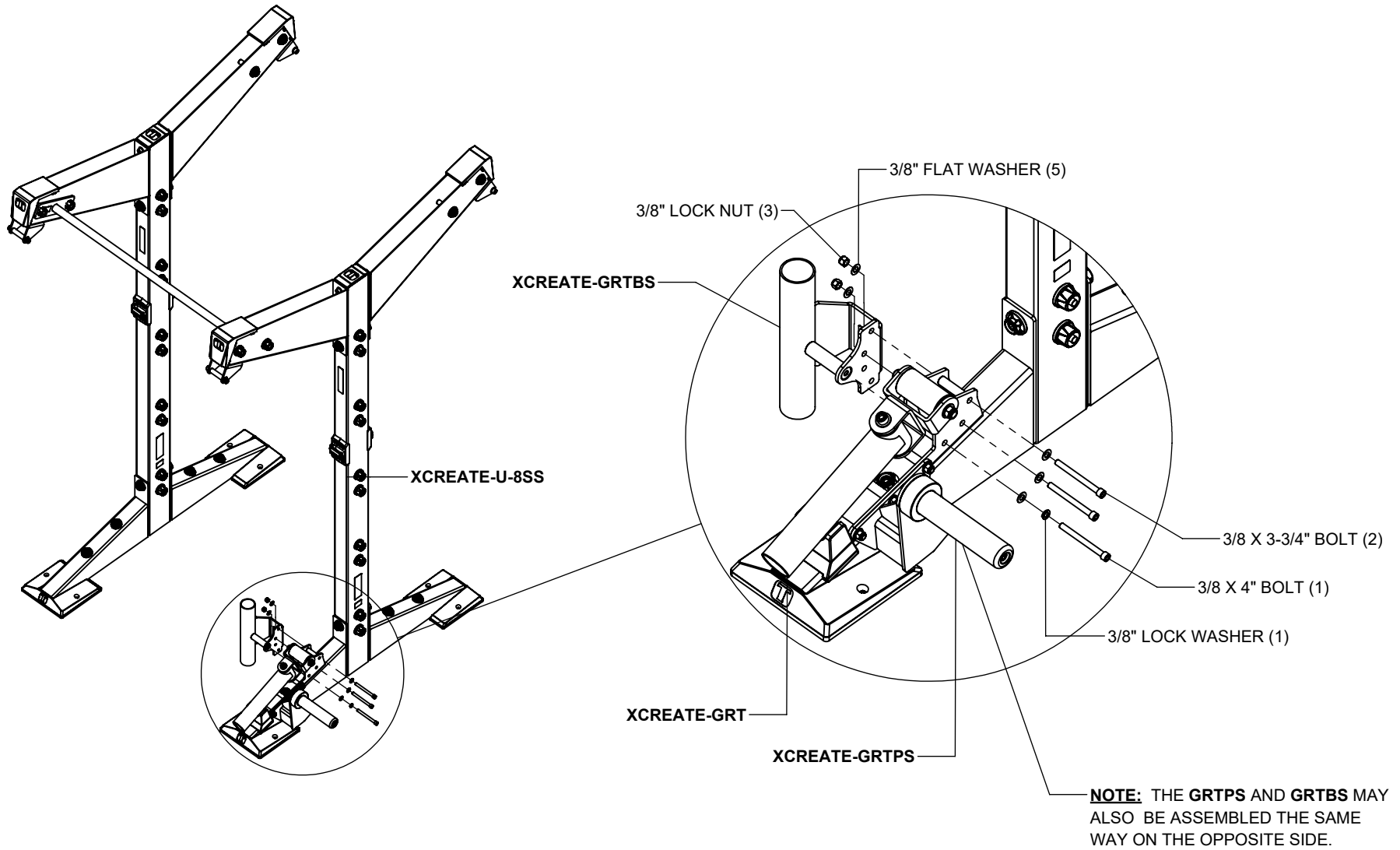

**NOTES:**

The **XCREATE-U-7SS** is assembled the exact same way.

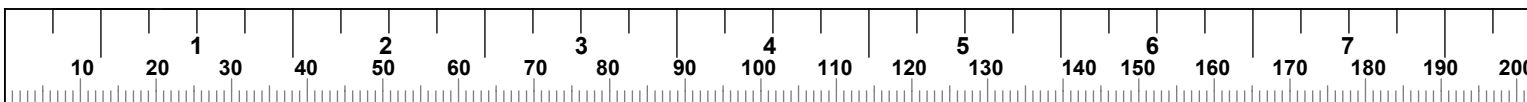

## 4' OFFSET STALL BAR

**NOTE:**

XCREATE-CC SHOWN, FOLLOW THE SAME STEPS FOR ASSEMBLING TO ANY CABLE MODULE.

**NOTE:**

LOOSEN CROSSMEMBER HARDWARE IF ALREADY ASSEMBLED. IF ASSEMBLING THE CABLE STATION AT THE SAME TIME, FOLLOW THESE STEPS BEFORE FULLY TIGHTENING HARDWARE.

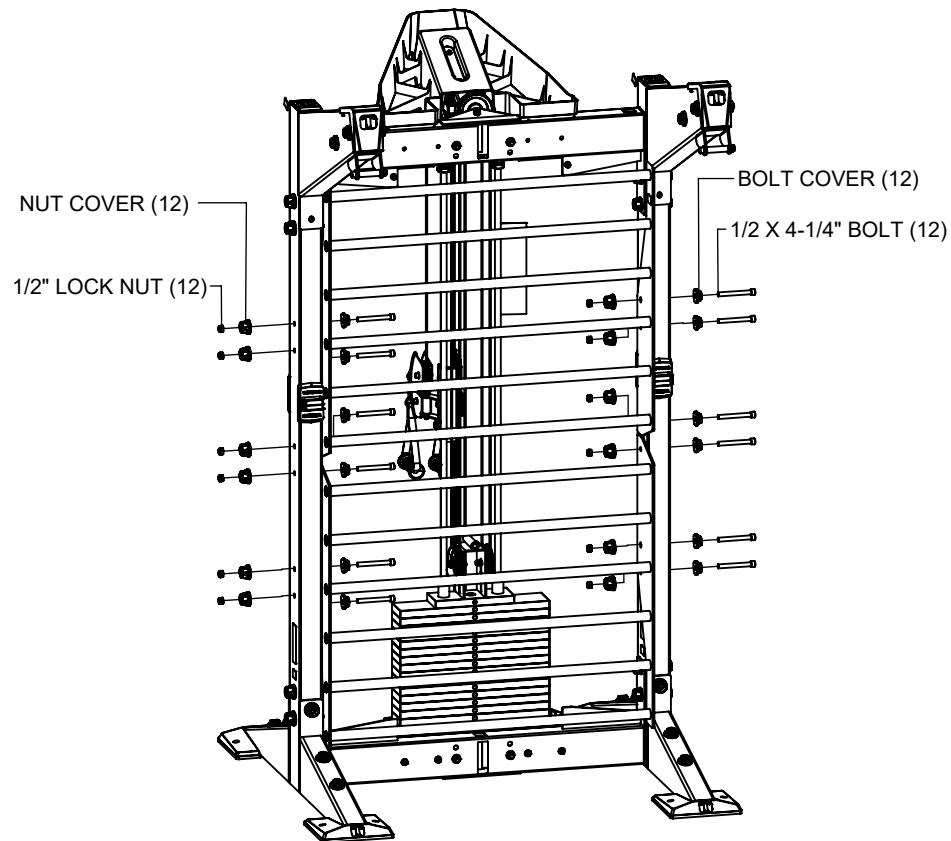
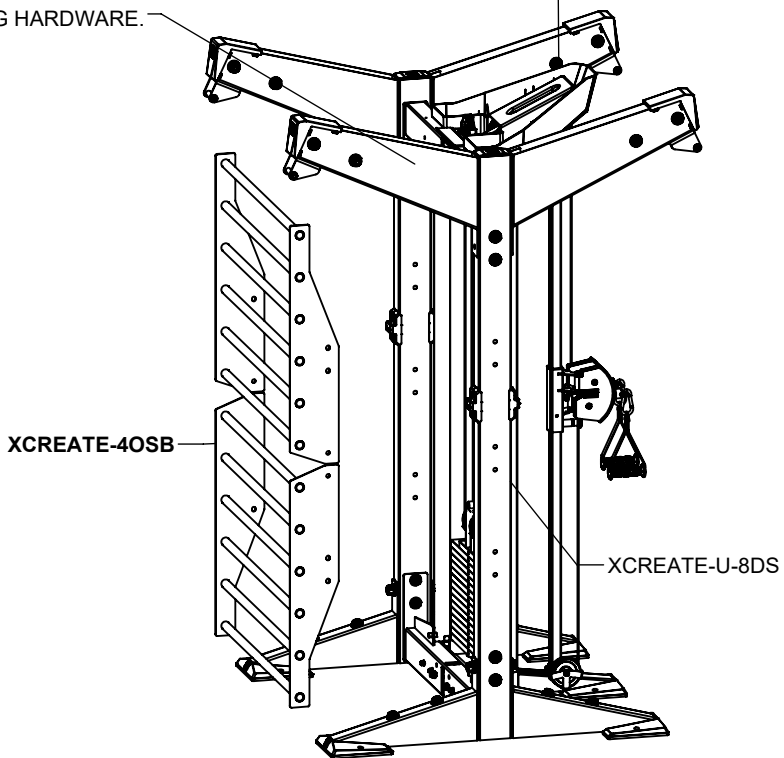

**NOTES:**

If more modules will be assembled, do not tighten bolts at this time. If this is the only module being assembled, then **SECURELY** tighten all bolts in this step and previous steps.

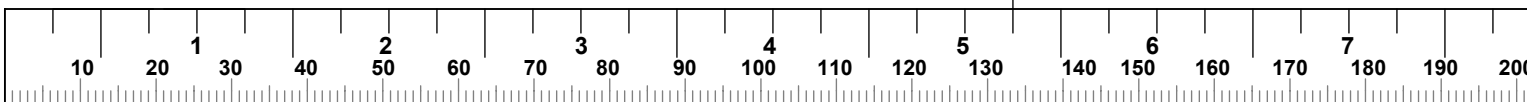

# DOUBLE SIDED UNIVERSAL HEAVY BAG ATTACHMENT

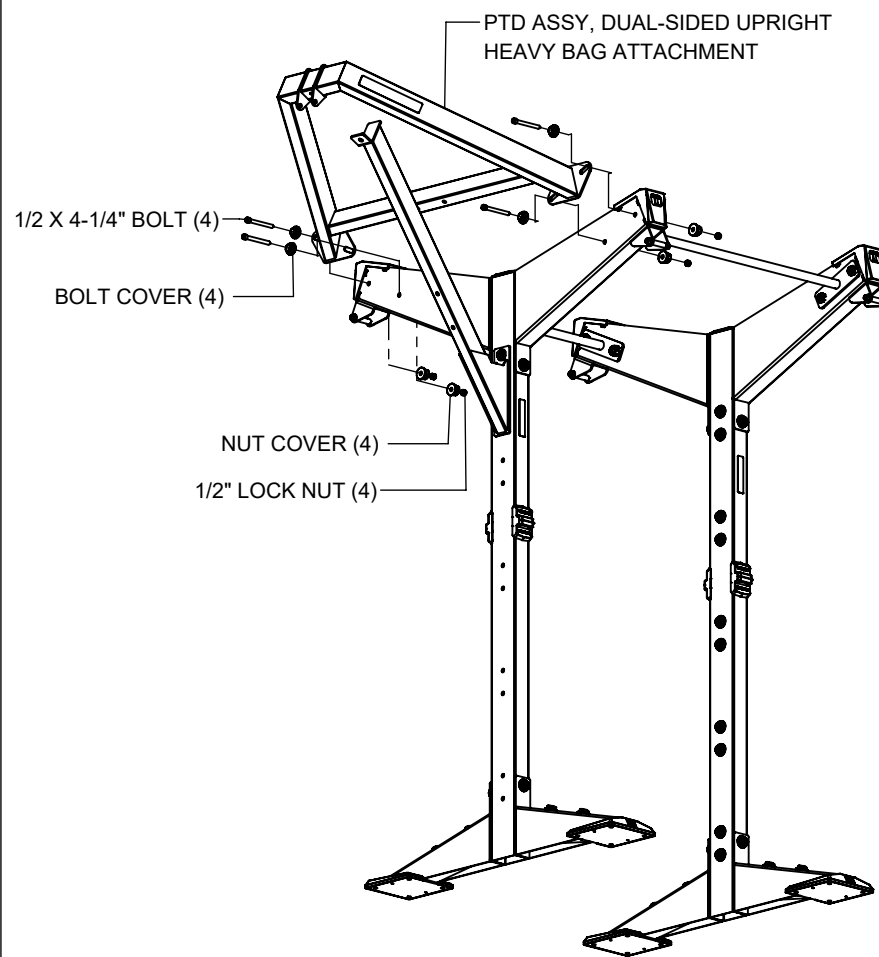
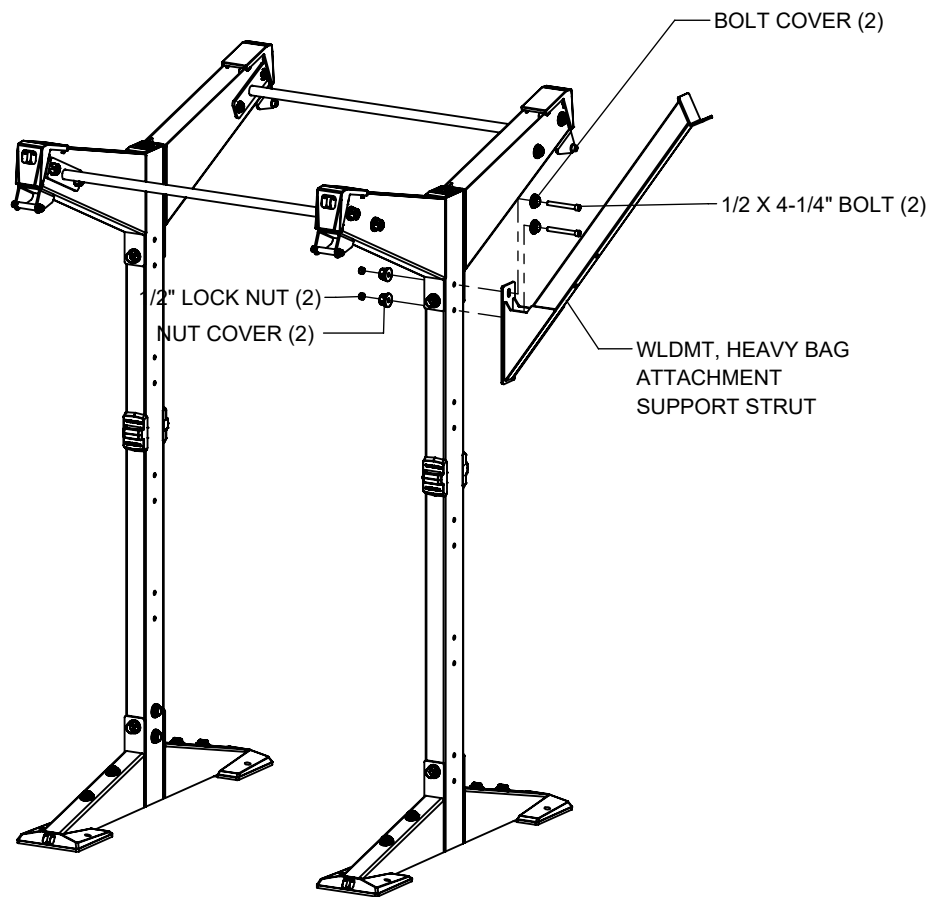

## NOTES:

**LOOSELY** tighten all bolts in this step and previous steps.

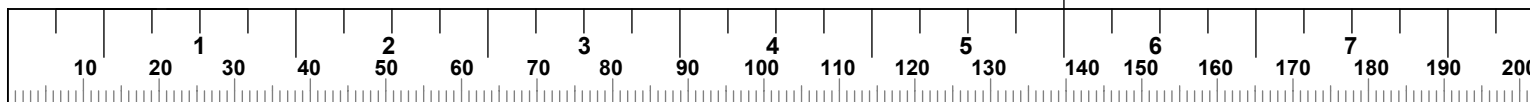

# DOUBLE SIDED UNIVERSAL HEAVY BAG ATTACHMENT

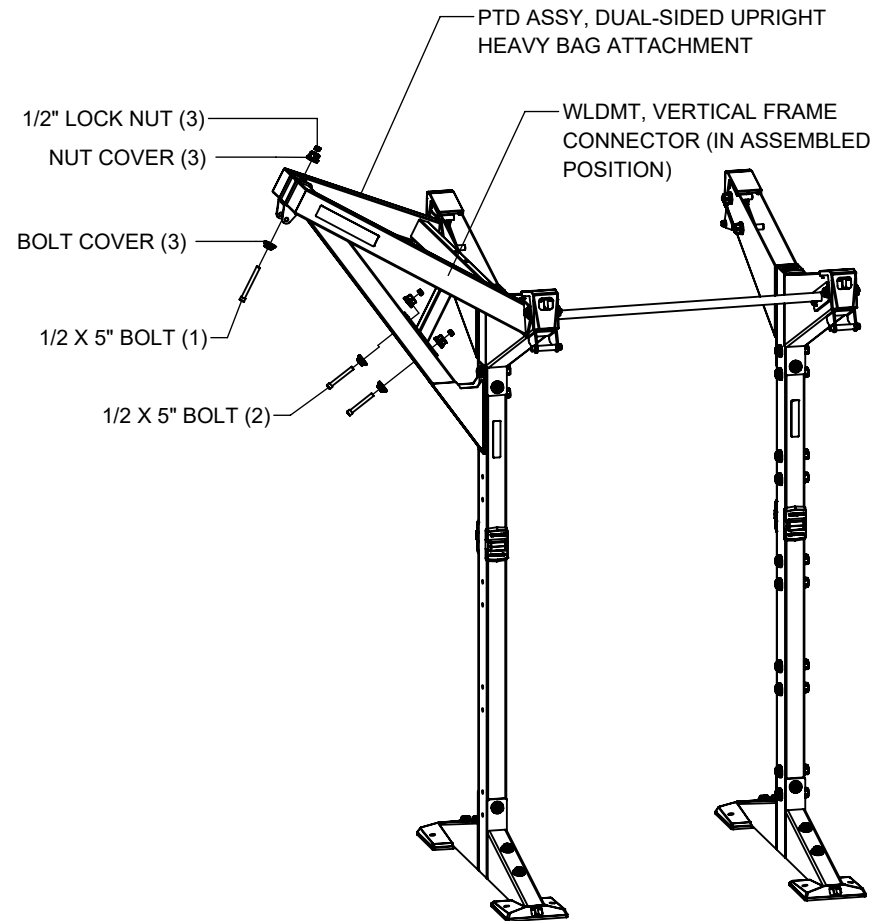
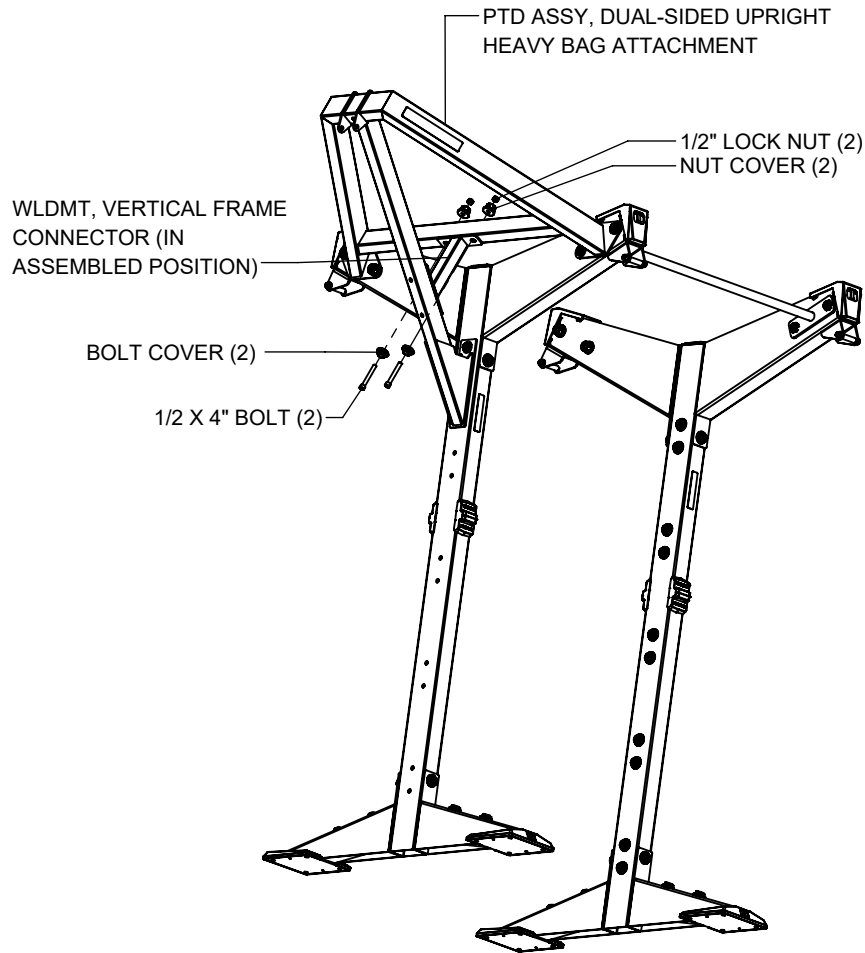

## NOTES:

**SECURELY** tighten all bolts in this step and previous steps.

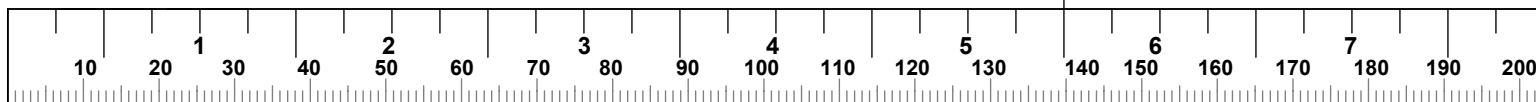

# DOUBLE SIDED UNIVERSAL HEAVY BAG ATTACHMENT

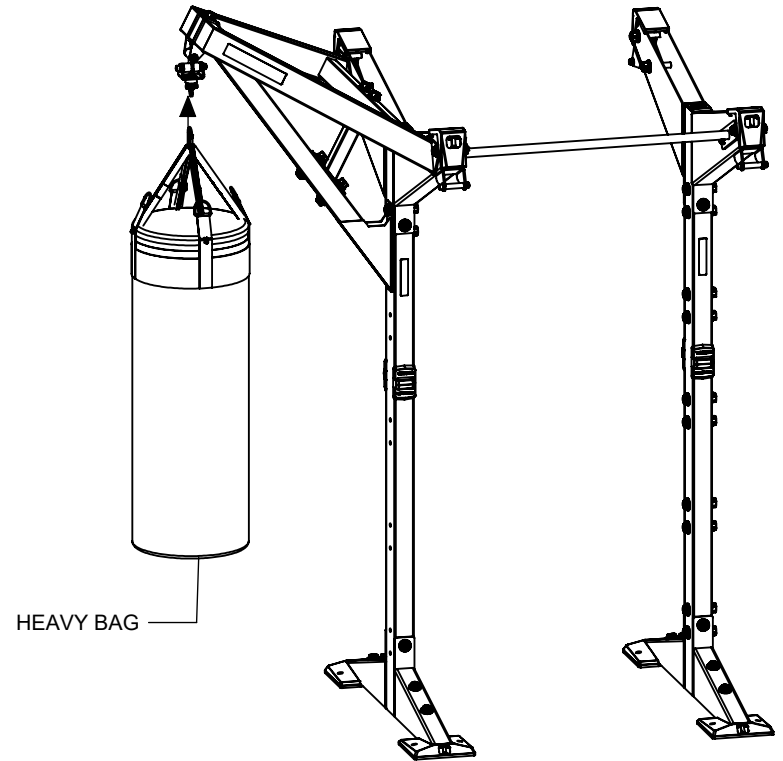
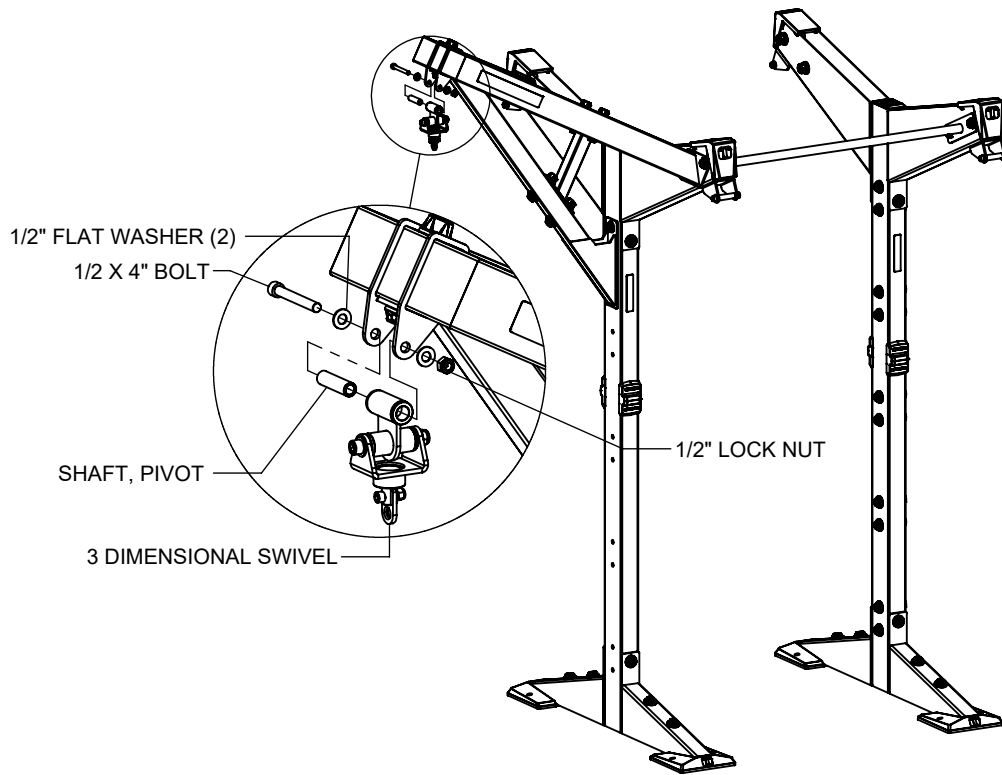

## NOTES:

**SECURELY** tighten all bolts in this step and previous steps.

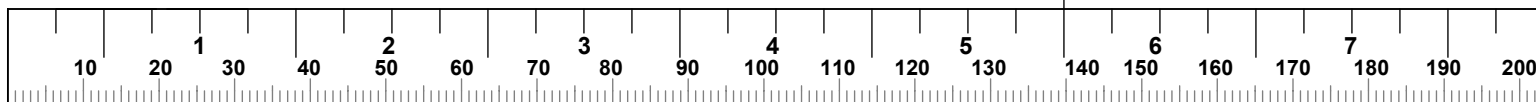

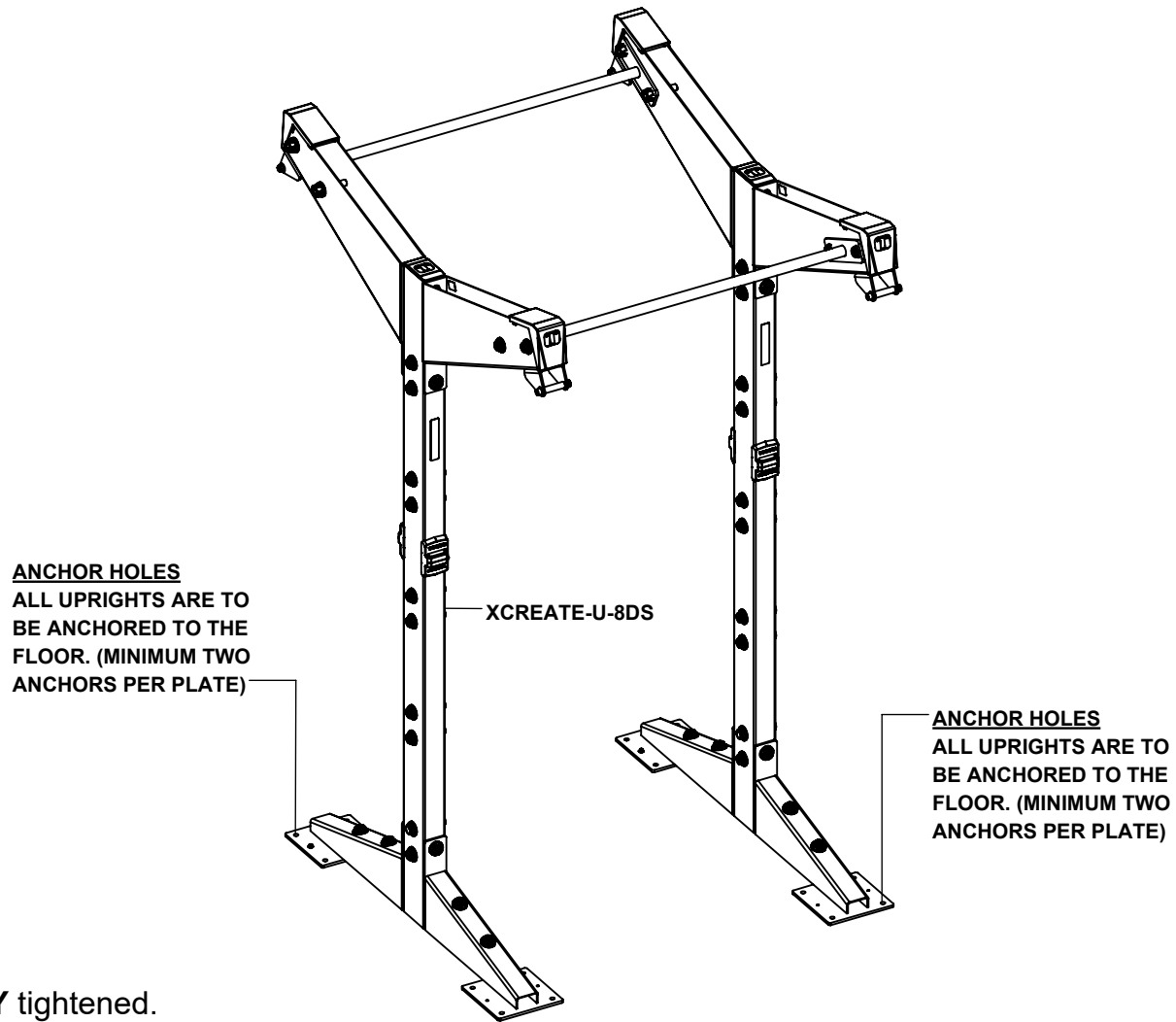

**NOTES:**

Make sure all bolts are **SECURELY** tightened.

Position system to desired location in the room.

Anchor system to the floor referencing X-CREATE ANCHORING INSTRUCTIONS which can be downloaded at [www.torquefitness.com/assembly-manuals](http://www.torquefitness.com/assembly-manuals)

**WARNING!**

**ALL X-CREATE ARE REQUIRED TO BE ANCHORED TO THE FLOOR TO PREVENT ROCKING OR TIPPING DURING USE.**

## XCREATE-URETHANE BOOTS

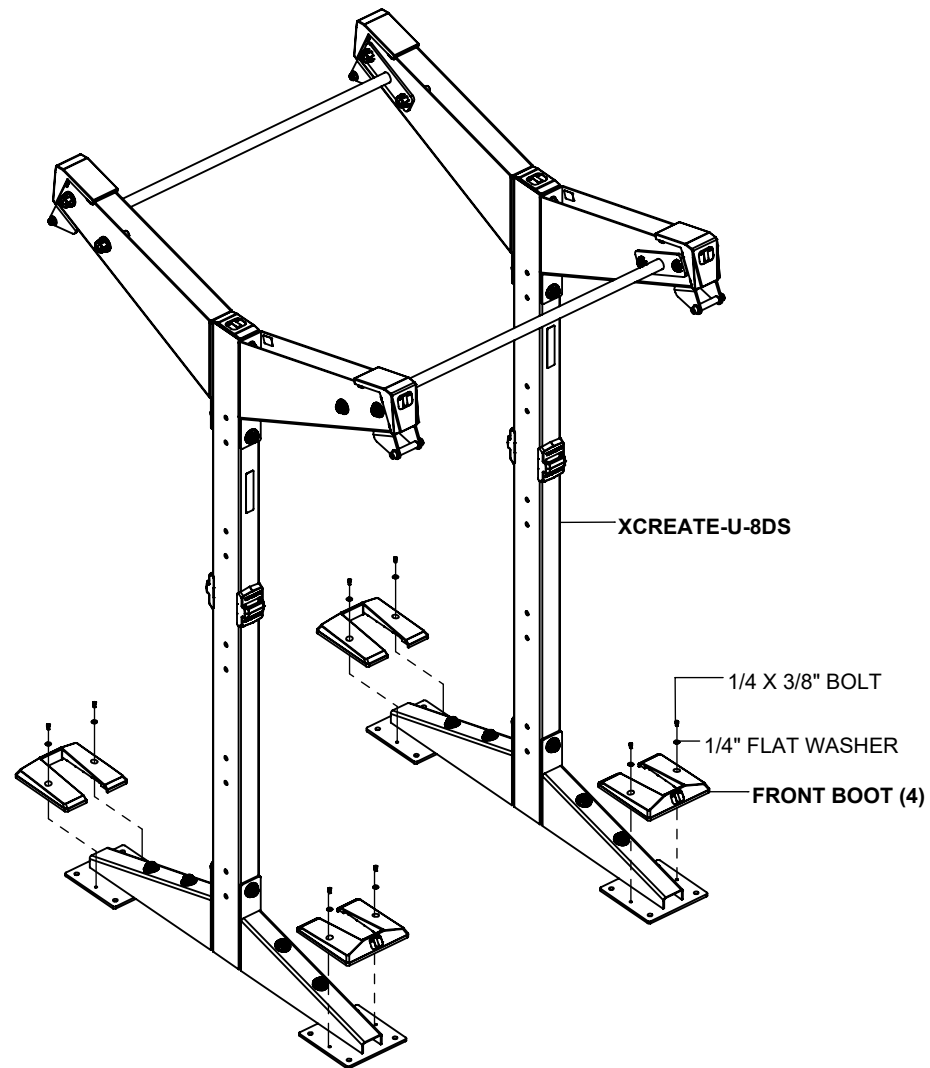

### NOTES:

The URETHANE BOOTS and hardware are packaged with the upright boxes

**SECURELY** tighten bolt connections in this step.

Repeat this step for every upright.

