

## ***ASSEMBLY INSTRUCTIONS***

### **4 FT (1.2 M) BACK EXTENSION MODULE**

# WARNING !

## Important safety instructions for using Equipment

There is a risk assumed by the individuals who use this type of equipment. To minimize risk, you must follow these precautions:

1. **READ ALL INSTRUCTIONS AND WARNING LABELS COMPLETELY PRIOR TO ANY USE OR ASSEMBLY.** Failure to read and follow the safety instructions and warnings within the Assembly and Maintenance Guide may result in possible serious injury or death. Use this product only for the intended uses described in the Assembly and Maintenance Guide and exercise booklet. **DO NOT** modify equipment in anyway. **Any use other than as intended or modification of product will void any and all product warranties.**
2. Consult your physician before starting any exercise program. Warm up properly before engaging in resistance training. Stop exercising and consult a physician immediately if you experience dizziness, nausea, faintness, chest pain, shortness of breath or any other abnormal symptoms during use of this equipment.
3. Certain exercise equipment and/or equipment may not be suitable or appropriate for pregnant women, people with heart conditions, balance impairment or other pre-existing health problems. Persons with disabilities should consult a physician and obtain medical approval prior to using this product and should only use this product under close supervision. **Failure to comply with these instructions will void any and all product warranties.**
4. Carefully inspect equipment before each use. Replace all parts at the first sign of wear or damage. Tighten all loose connections. Pay special attention to cable ends and connections. Do not disassemble, remove any parts or components or otherwise attempt to repair this product. **DO NOT** use product if product appears damaged. **DO NOT** attempt to fix a broken or jammed machine, obtain assistance from your authorized Torque Fitness Dealer. **Failure to comply with these instructions will void any and all product warranties.**
5. Keep body and clothing clear of all moving parts. Do not put any foreign on or near this product when in use. Wear comfortable clothing which does not impair freedom of movement. Do not wear clothing which is too loose and could get caught in moving parts.
6. Make sure all adjustment spring pins are fully engaged after making an adjustment and before using the product.
7. Make sure weight stack selector pin is completely inserted into the weight stack before beginning any exercise.
8. Children and pets must not be allowed near this machine. Supervise teenagers. This product is not a toy. Owner must notify any user of all warnings and proper use of equipment.
9. This product is designed for Class S, Studio or Commercial indoor use only. Unless directly specified, the maximum user weight is 300 lb (136 kg). If unsure of proper use of this product, contact Torque Fitness Customer service at: **763-754-7533** (8:30 am - 5:00 pm CST) or email **service@torquefitness.com**

## Important Safety Instructions for Assembling Equipment

1. **Assistance is required. Torque Fitness recommends using more than one person to assemble this equipment.**
2. This product must be assembled on a flat, level surface to assure its proper function. Locate the unit a few inches from walls or furniture to allow easy access during assembly and use.
3. Read each numbered step in Assembly and Maintenance Guide and follow the steps in sequence. Skipping ahead may result in damage to the equipment and may require components to be disassembled.
4. Wear proper attire during the assembly process. Do not wear clothing which is too loose or open toed shoes.

## Obtaining Service

Do not attempt to service the product yourself except for maintenance tasks described in this manual.

Refer to the Adjustments and Maintenance section at the back of this manual and the included workout booklet for information on product operation and service.

For further information, visit our website at **www.torquefitness.com** or contact us at **service@torquefitness.com**

If you call or email customer service, have the model number and serial number(s) available. The location of the model and serial numbers are indicated in the back of this manual. For future reference, write the model and serial number(s) in the space below.

Model Number: \_\_\_\_\_

Serial Number(s): \_\_\_\_\_

**Torque Fitness**  
**11201 Xeon Street NW Suite 101**  
**Coon Rapids, MN USA 55448**

# GENERAL NOTES

**CAUTION:** More than one person is required to assemble this unit. Do not attempt to assemble by yourself.

## Unpacking the Equipment

This product may be packaged and shipped in multiple boxes. Parts from all of the boxes are required for various steps during the assembly process.

Carefully open each box and arrange all the parts near the area where assembly is to take place.

**CAUTION:** Use extreme care when cutting plastic tie wraps and package banding. A wire cutter works best for protecting yourself and the parts.

**CAUTION:** Some of the internal boxes may contain upholstery. Do not use a utility knife to open any boxes or the pads may be damaged.

The hardware is packed in bags. Carefully open each bag and sort them per parts list on the next page.

Before starting assembly, identify each part and hardware item as listed in the parts list on the next page. If any items are missing, contact Torque Fitness Customer service at: **763-754-7533** or **service@torquefitness.com**

**Note:** Some items listed in the parts list may be pre-installed on the product.

## Tools Required

- 3/8" Allen wrench
- 5/16" Allen wrench
- 3/16" Allen wrench
- 3/4" Wrench and or socket
- 9/16" Wrench and or socket
- 1/2" Wrench and or socket
- Rubber mallet
- Wire snips (to cut plastic tie wraps)
- Scissors or utility knife (to cut hardware bags)
- Step stool or ladder
- Tape measure

## Optional Equipment

Optional equipment may be available for this product.

Follow the instructions included with the optional equipment to assemble it to the base product.

## Assembly Tips

- In a continual effort to improve our products, specifications are subject to change.
- A 6" scale is provided at the bottom of this page. To correctly measure the bolts, measure from underneath the bolt head to the end of the bolt as illustrated below.
- Read all notes on each page before beginning that step.
- Some of the items shown in the assembly steps may be pre-assembled.

## Assembly Tips Continued

- **Note:** Some items have been hidden for assembly clarity.
- **Note:** Some pre-assembled parts may need to be temporarily removed in order to complete the step. Follow the instructions or damage to the product could occur.
- Some parts may have extra holes that will not be used. Use only the holes depicted in the instructions.
- Certain parts make reference to the right and left side of the machine. In order to determine the left and right side, stand in front of the machine.
- Provide ample space around the product for ease of assembly.
- **DO NOT** fully tighten any connections until instructed to do so. This will help insure that the alignment of all of the parts will be correct.
- Insert all bolts in the direction indicated in the instructions. Failure to do so may result in clearance issues and will degrade the aesthetics of the product.
- Carefully follow instructions for all pivot points. In general, primary rotating parts have connections that should be securely tightened, while secondary connections need to be loosen 1/4 turn.

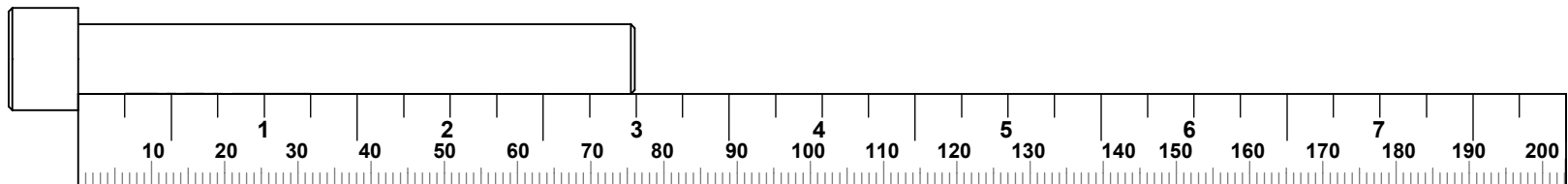

ITEM NO.	PART NUMBER	DESCRIPTION	QTY
1	60248PA	PTD ASSY, BACK EXTENSION FRAME	1
2	60254PA	PTD ASSY, ANGLED FOOTPLATE	1
3	60256PA	PTD ASSY, FLAT FOOTPLATE	1
4	59148PA	PTD ASSY, SEATED ROW TOP BOOM	1
5	6025801	WLDMT, ROLLER PAD TUBE	1
6	5699301	PAD, SHORT ROLLER	2
7	60282PA	PTD ASSY, BACK EXTENSION HANDLE	1
8	60284PA	PTD ASSY, BACK EXTENSION HANDLE STORAGE	1
9	5643201	GUIDE ROD, 19 DIA X 1912	2
10	60263PA	PTD ASSY, BACK EXTENSION BASE	1
11	56345PA	PTD ASSY, HEAD PLATE	1
12	5662501	WLDMT, LEFT SHROUD BASE	1
13	5662901	WLDMT, RIGHT SHROUD BASE	1
14	6028501	CABLE, BACK EXTENSION	1
15	5094501	PULLEY, 4-1/2 OD X 25	1
16	60268PA	PTD ASSY, BACK EXTENSION PAD SUPPORT	1
17	6028301	PAD, BACK EXTENSION	2
18	6028601	PLACARD, XCREATE BACK EXTENSION	1
19	6065001	LABEL, WEIGHT STACK 15 - 190 LB (6.8 - 86.2 KG)	1
20	6028701	ASSY INST, BACK EXTENSION MODULE	1
21	6032001	CAP, ANTI-SPIN ROLLER PAD END	2
22	55181PA	PTD ASSY, WEIGHT SELECTOR STORAGE PLATE	1
23	5513601	CUSHION, WEIGHT STACK	2
24	5996401	BUSHING, GUIDE ROD RETAINER	2
25	5992401	SHAFT COLLAR, TWO-PIECE CLAMPING	2
26	6065101	HOUSING, CABLE COUPLER	1
27	5509001	CORE, CABLE COUPLER	1
28	2003201	CAP SCREW, M5 X 0.8 X 6MM SOCKET HEAD	2
29	6068601	QUICK LINK, HANDLE ATTACHMENT	1
30	5631801	WASHER COVER, NYLON BOLT	10
31	2001401	NUT, 1/2-13 LK ST ZN	15
32	5631901	WASHER COVER, NYLON NUT	8
33	2001301	WASHER, FLAT 1/2 SAE ST ZN	18
34	2005816	BOLT, 1/2-13 X 4-1/4" (108mm) SOCKET HEAD	6
35	2009418	BOLT, 3/8-16 X 4-3/4" (121mm) ST HT SOCKET HEAD W/NP	2
36	2001101	WASHER, FLAT 3/8 SAE ST ZN	22
37	2008407	BOLT, 3/8-16 X 2" (51mm) ST HT SOCKET HEAD	1
38	2001201	NUT, 3/8-16 LK ST ZN	7
39	2006804	BOLT, 1/2-13 X 1-1/4" (32mm) SOCKET HEAD W/NP	2

ITEM NO.	PART NUMBER	DESCRIPTION	QTY
40	2002101	WASHER, FLAT 1/4 SAE ST ZN	6
41	2009402	BOLT, 3/8-16 X 3/4" (19mm) ST HT SOCKET HEAD W/NP	2
42	2006502	BOLT, 1/4-20 X 1/2" (13mm) SOCKET HEAD W/NP	6
43	2004103	BOLT, 3/8-16 X 1" (25mm) FLAT HEAD	2
44	2006811	BOLT, 1/2-13 X 3" (76mm) SOCKET HEAD W/NP	4
45	2009403	BOLT, 3/8-16 X 1" (25mm) ST HT SOCKET HEAD W/NP	10
46	2005828	BOLT, 1/2-13 X 7-1/4" (184mm) SOCKET HEAD	1
47	5915101	WLDMT, CABLE STATION CROSS	2
48	5360001	LABEL, SERIAL-MARKING	1
49	2008414	BOLT, 3/8-16 X 3-3/4" (95mm) ST HT SOCKET HEAD	4
50	2008416	BOLT, 3/8-16 X 4-1/4" (108mm) ST HT SOCKET HEAD	8
51	5645101	SHROUD, XCREATE CABLE STATION	2
52	5664701	SHROUD, TOP CAP	1
53	56350PA	PTD ASSY, 15 LB WEIGHT PLATE	5
54	56349PA	PTD ASSY, 10 LB WEIGHT PLATE	10

**NOTE:**

**X-CREATE CABLE STATIONS can be customized in many ways. This manual provides instructions for assembling a single stand-alone unit. If you worked with Torque X-Team Design during the purchasing process, please request a Bill of Material Drawing to reference your exact set-up. For assistance, contact [sales@torquefitness.com](mailto:sales@torquefitness.com) or call (763) 754-7533.**

**NOTE:**

When assembling any X-CREATE CABLE STATIONS that are longer than one module wide, the hardware will be shared between two side-by-side modules. It is recommended to keep all bolt connections loose until all the cable stations have been fully assembled, then securely tighten all frame connections.

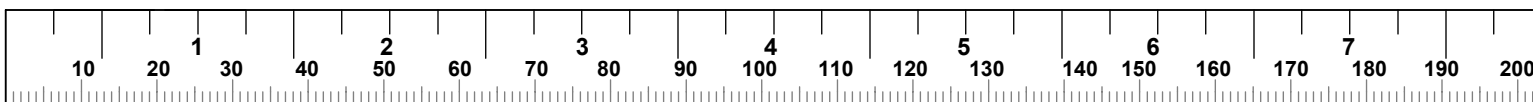

# STEP 1

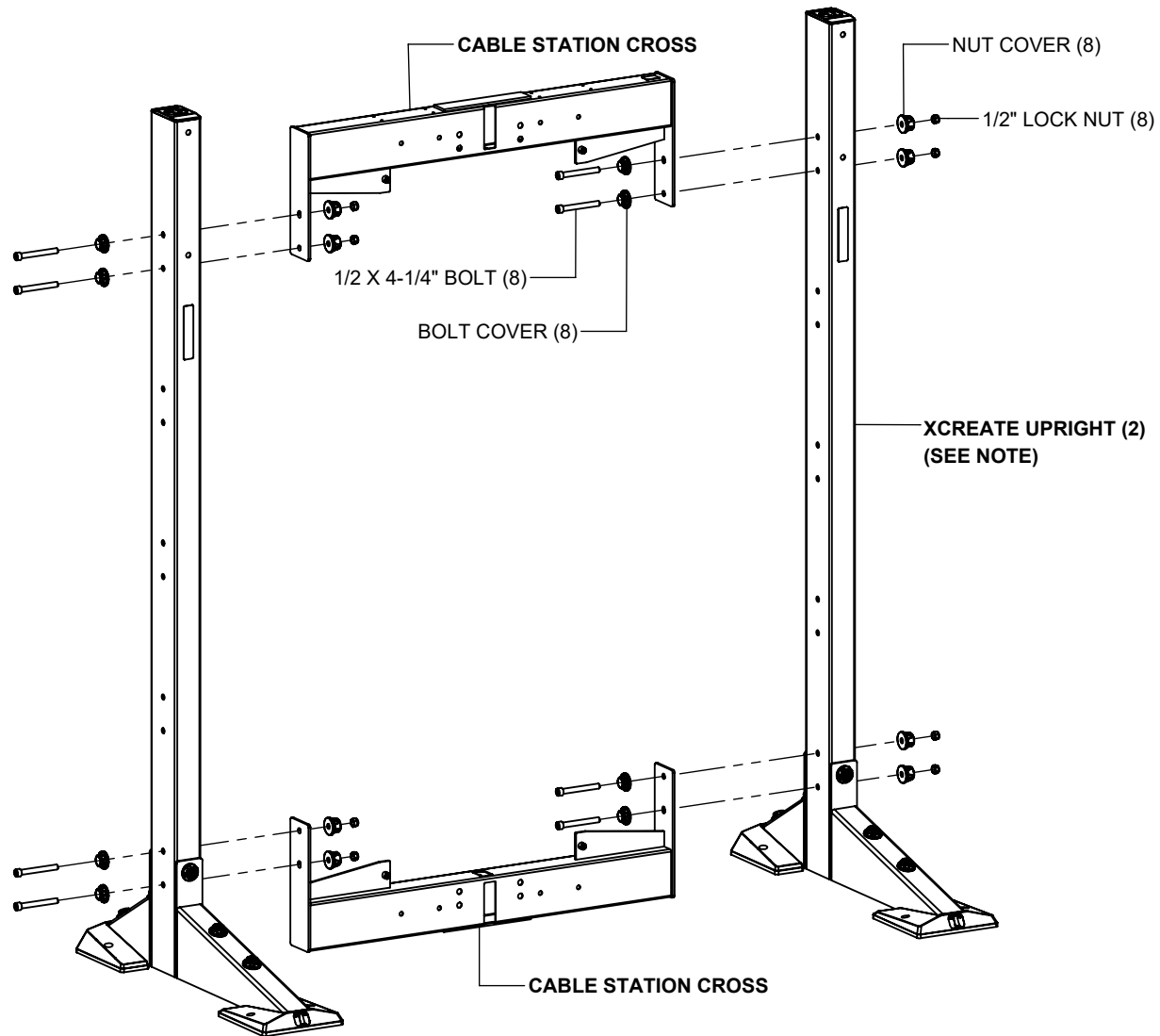

## NOTES:

**LOOSELY** tighten bolt connections in this step.

The XCREATE-4BEM is shown assembled to the XCREATE-7U.  
However, the XCREATE-4BEM can also be assembled to the  
XCREATE-8U and XCREATE-2S8U the same way.

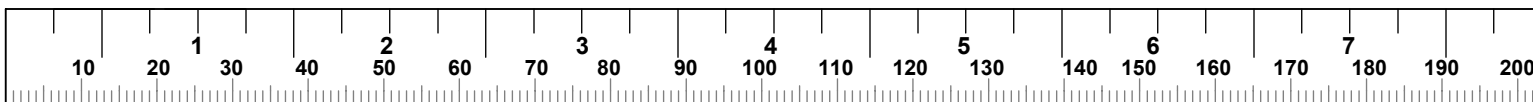

**STEP 2**

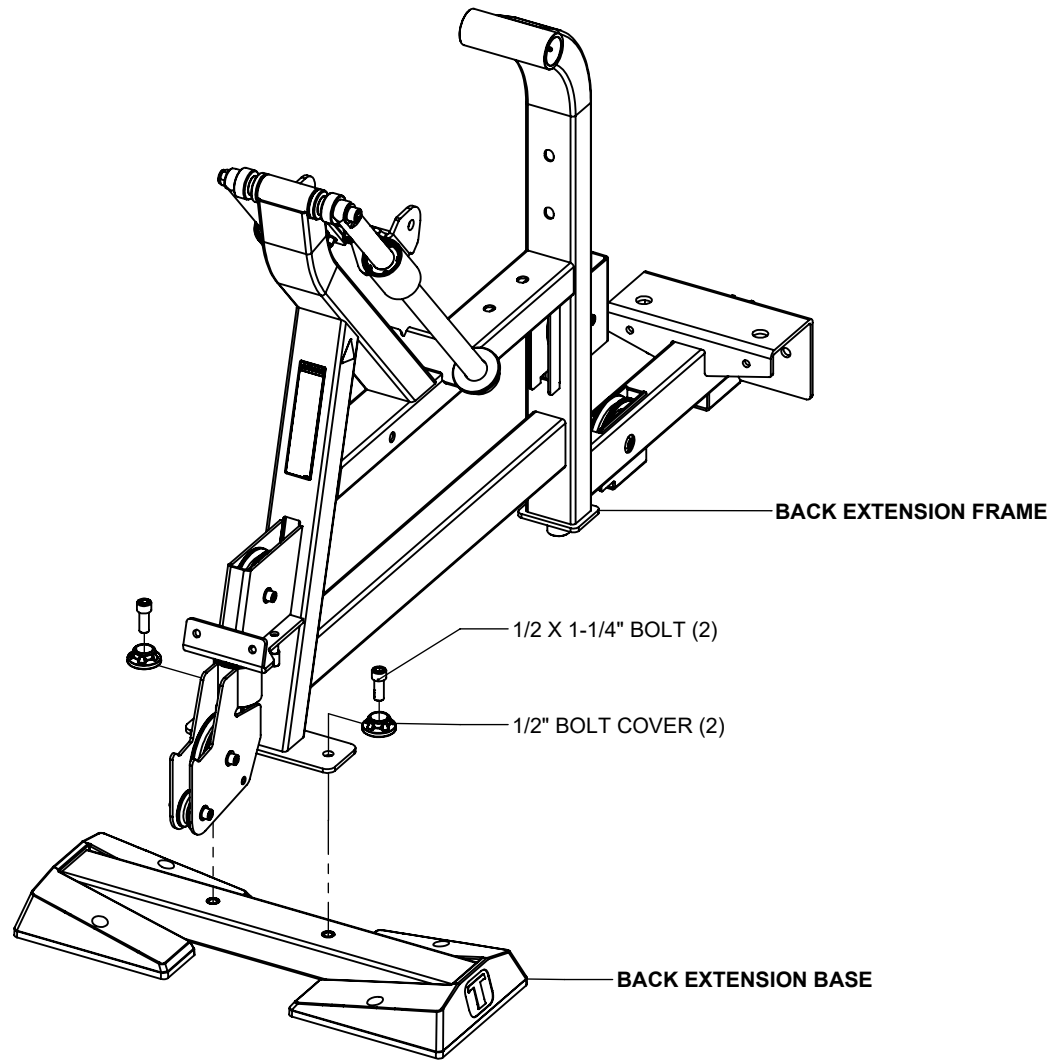

**NOTES:**

**SECURELY** tighten bolt connections in this step.

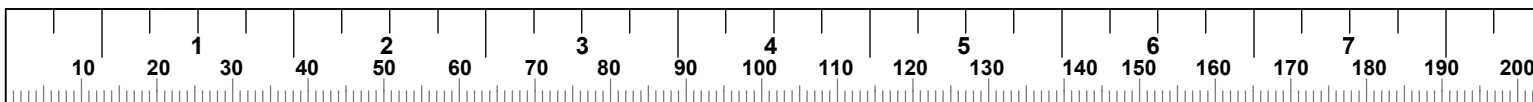

**STEP 3**

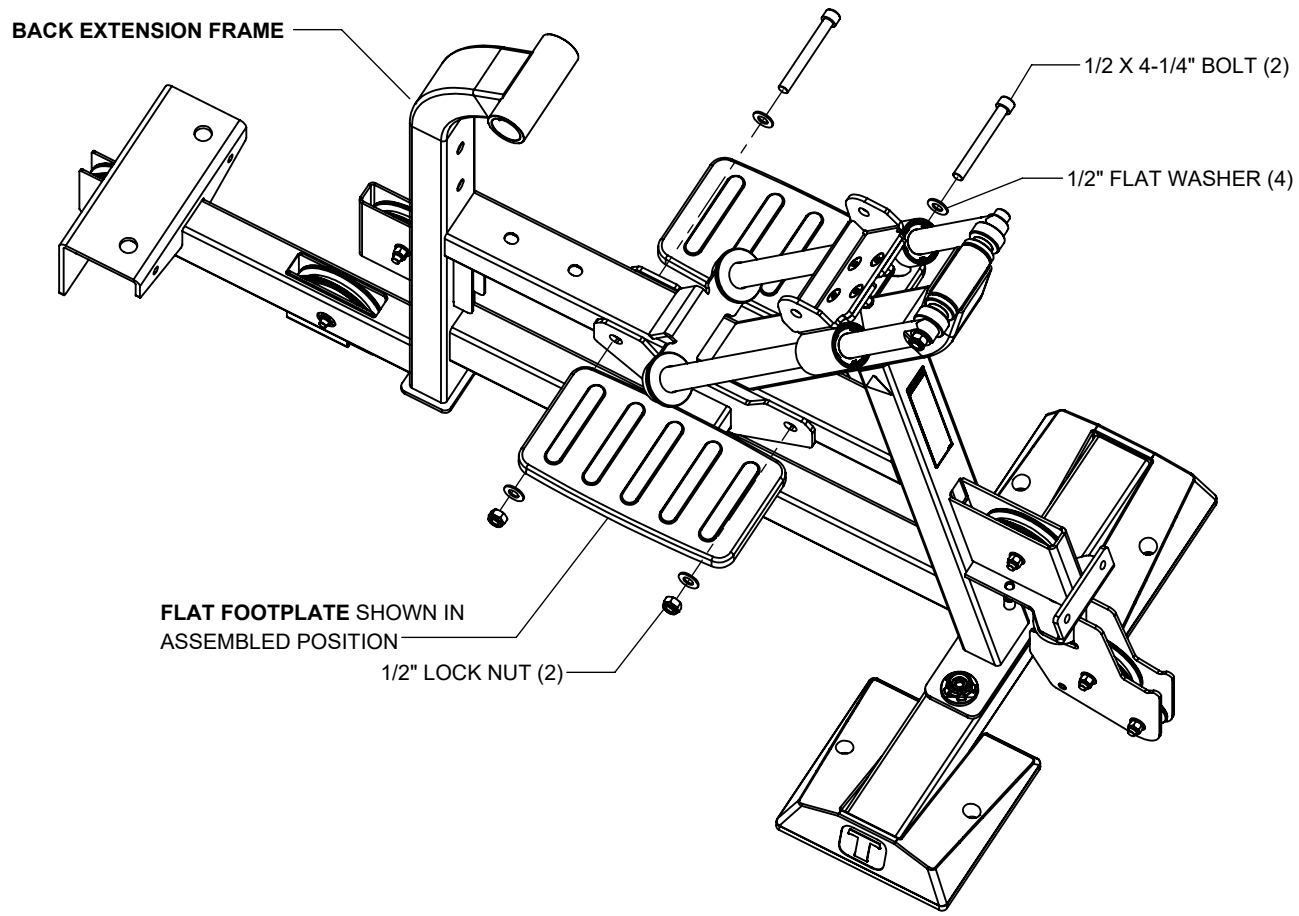

**NOTES:**

**SECURELY** tighten bolt connections in this step.

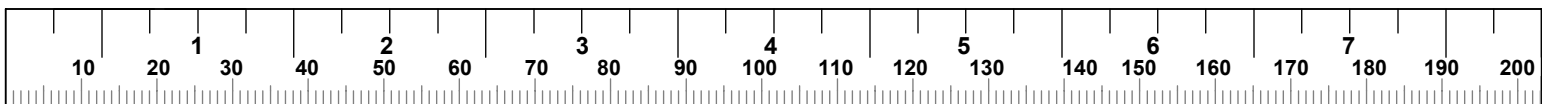

# STEP 4

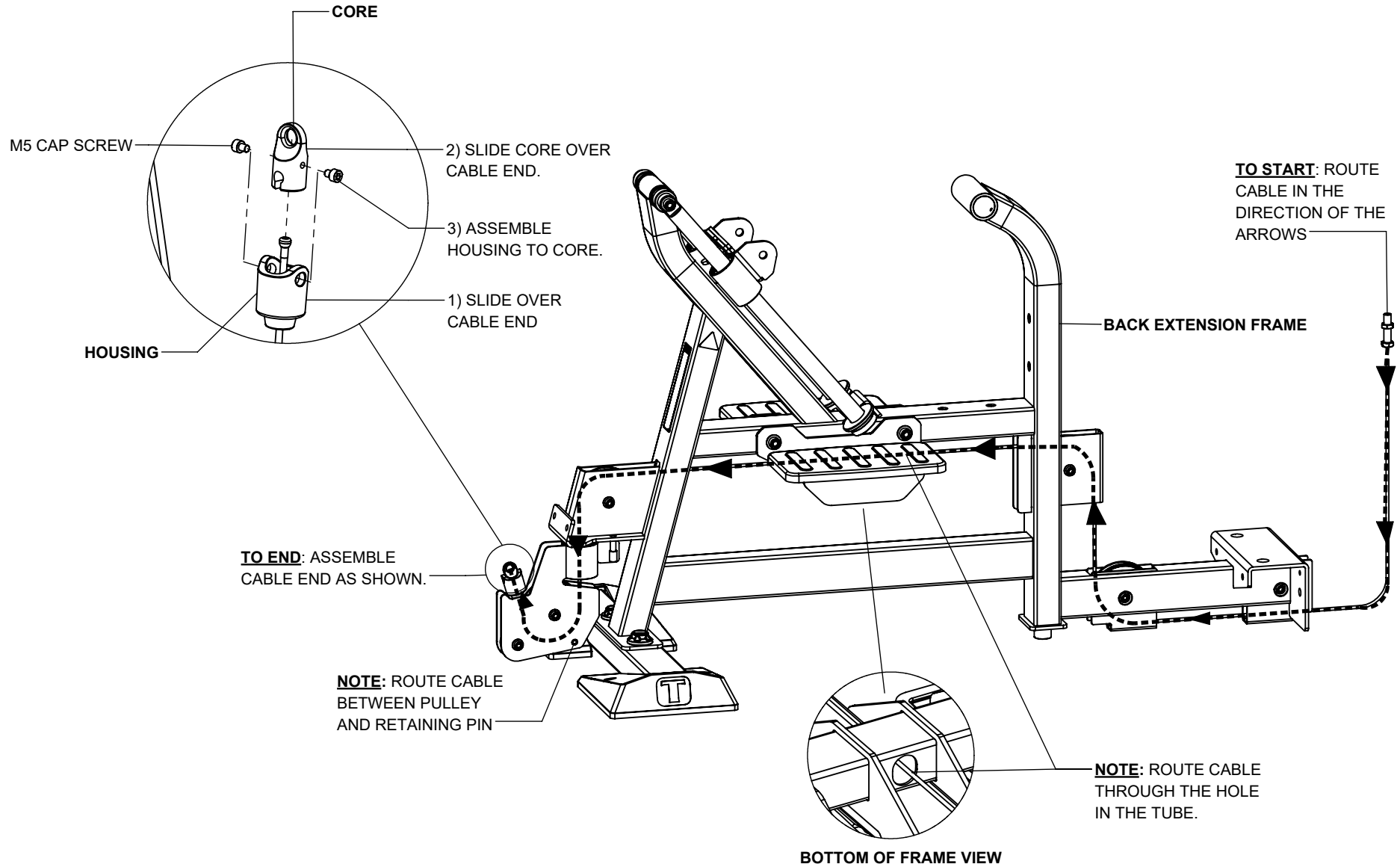

## NOTES:

**SECURELY** tighten bolt connections in this step.

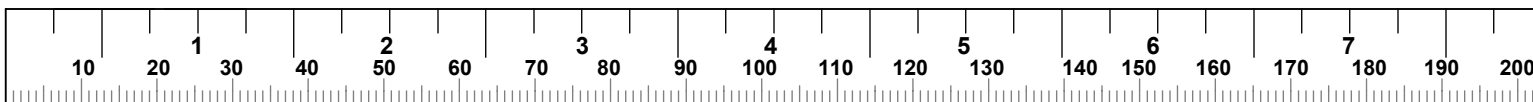

# STEP 5

**NOTE:** BEFORE ASSEMBLING BASE, ROUTE CABLE THROUGH THE FRONT SLOT AND OUT OF THE TOP SLOT AS SHOWN

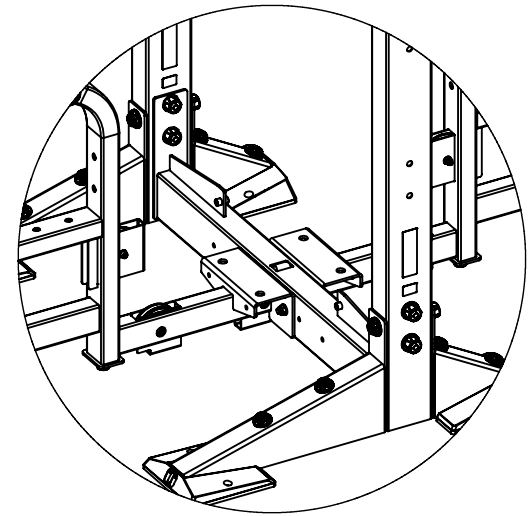
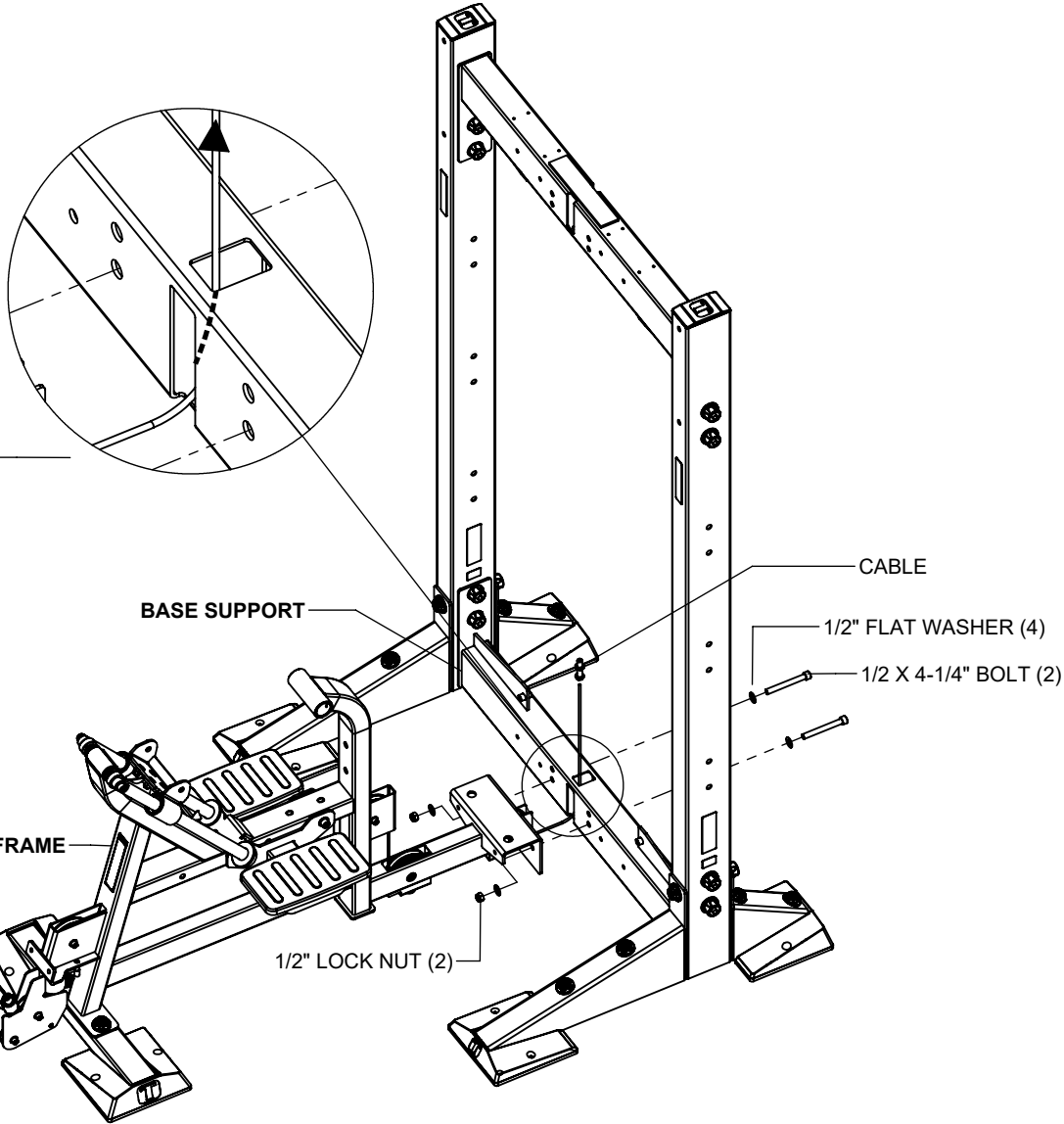

**NOTE:** IF ASSEMBLING CABLE STATIONS BACK TO BACK, PLEASE NOTE THAT THEY SHARE THE SAME BASE SUPPORT AND HARDWARE AS SHOWN. BOTH BASES NEED TO BE ASSEMBLED SIMULTANEOUSLY

## NOTES:

**SECURELY** tighten bolt connections in this step and previous step, except as noted.

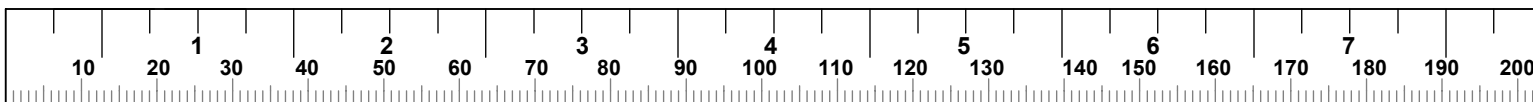

**STEP 6**

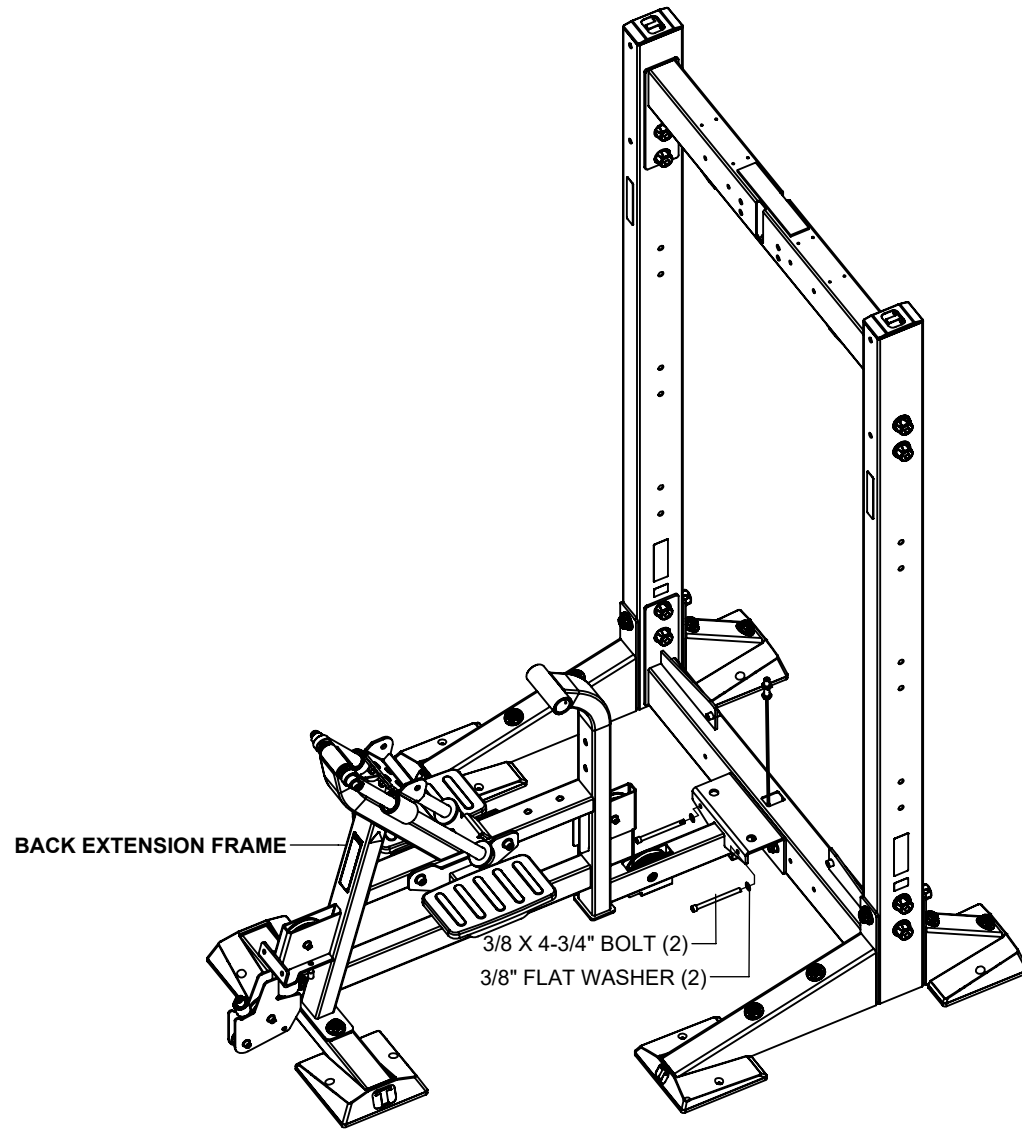

**NOTES:**

**SECURELY** tighten bolt connections in this step.

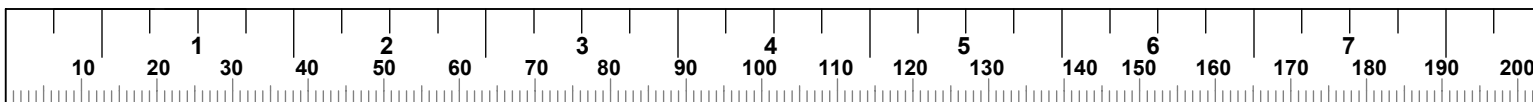

# STEP 7

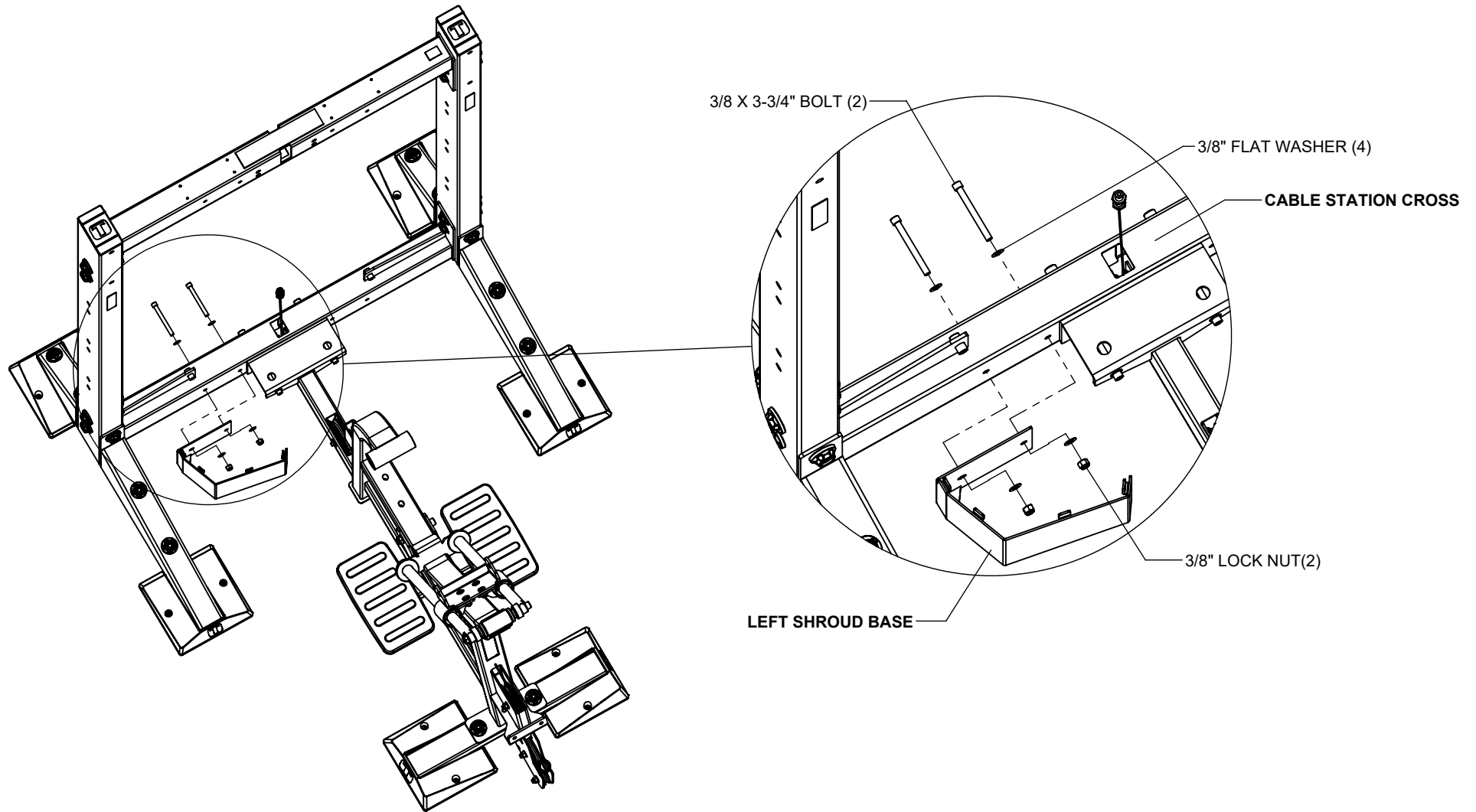

## NOTES:

**SECURELY** tighten bolt connections in this step.

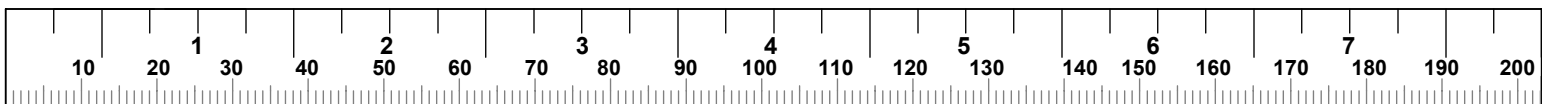

**STEP 8**

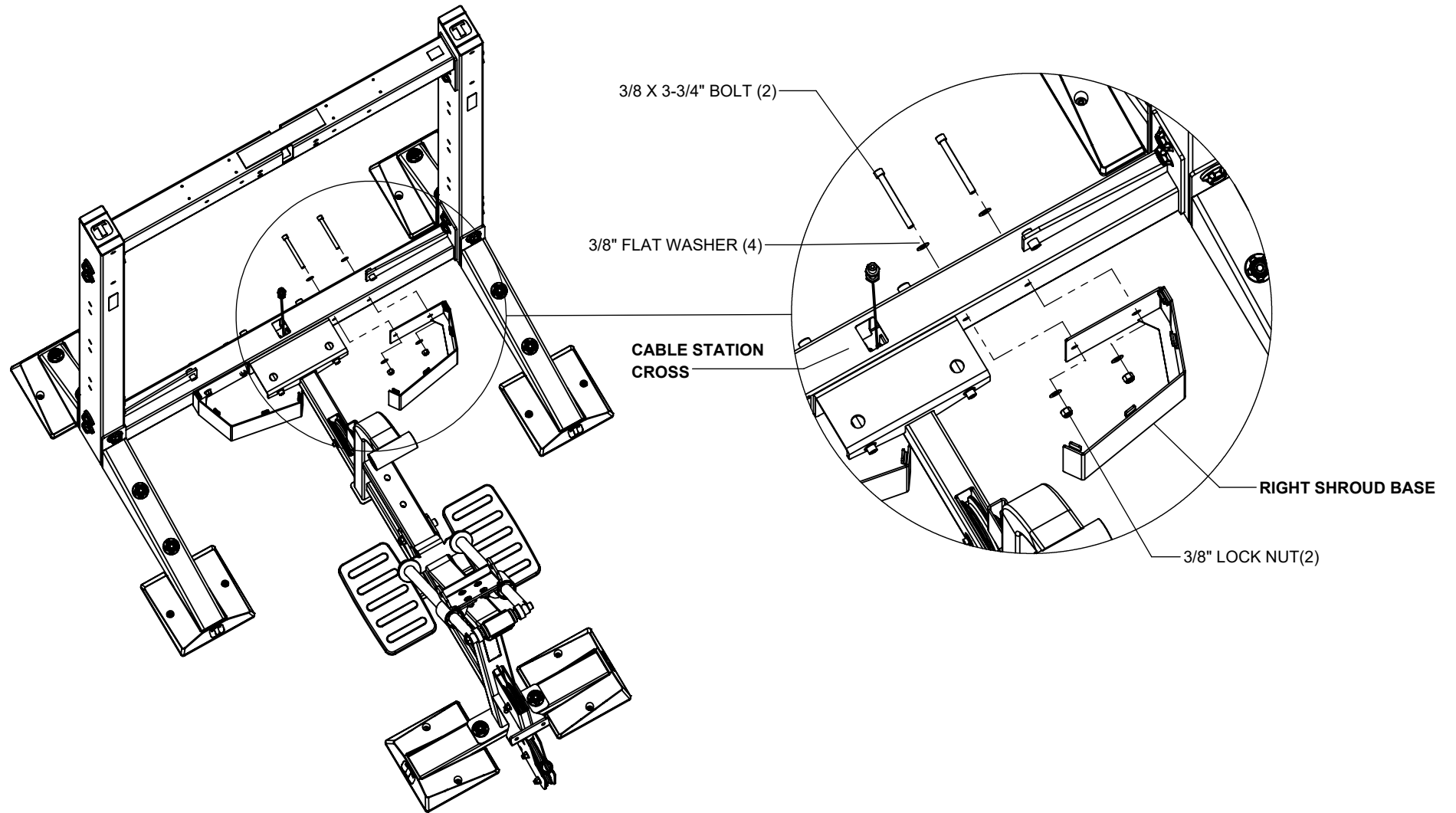

**NOTES:**

**SECURELY** tighten bolt connections in this step.

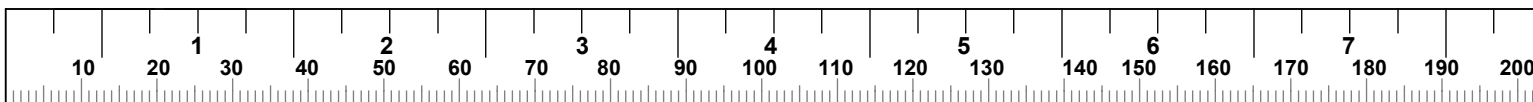

# STEP 9

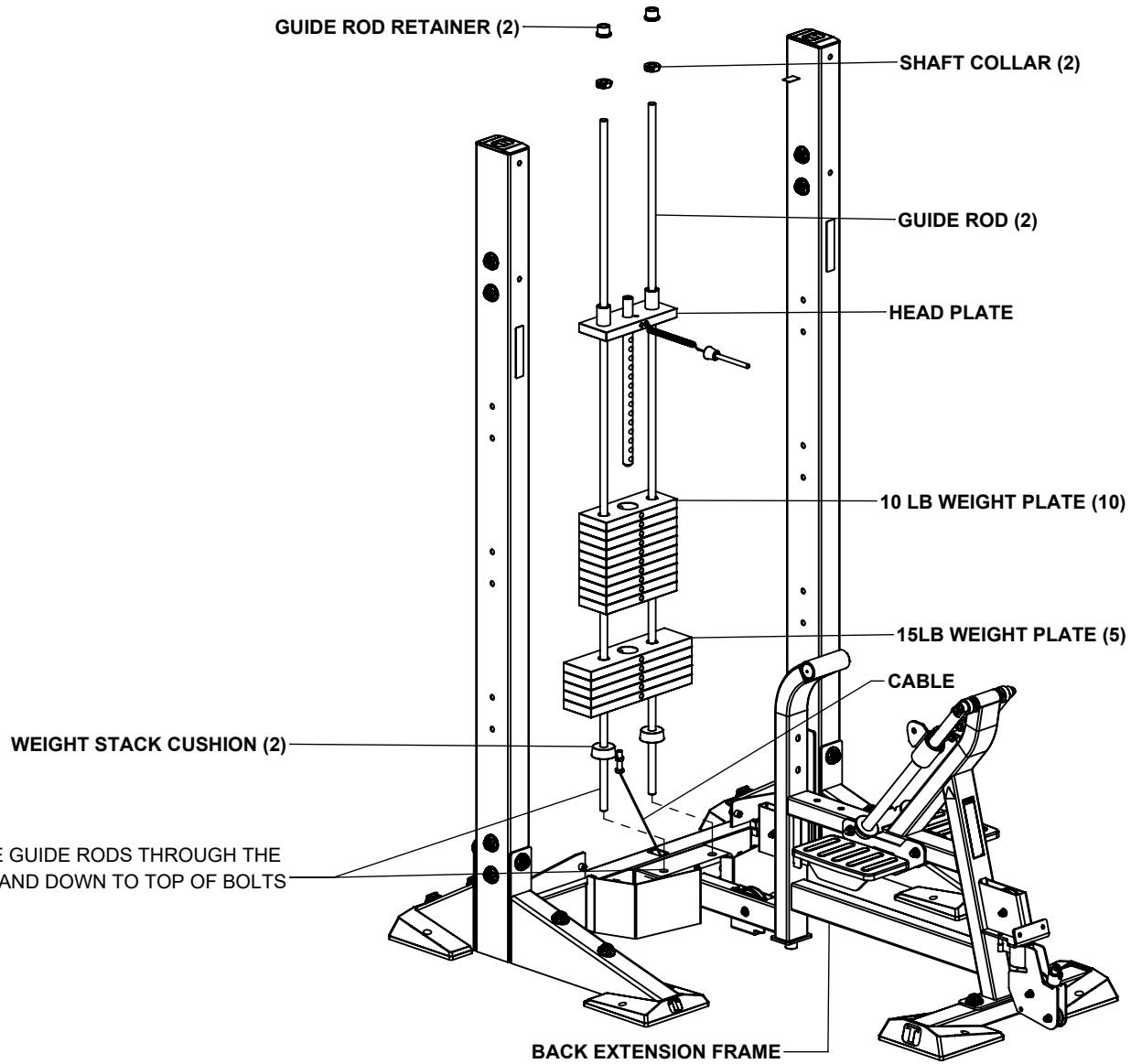

## NOTES:

TOP BOOM SUPPORT has been hidden for illustration clarity.

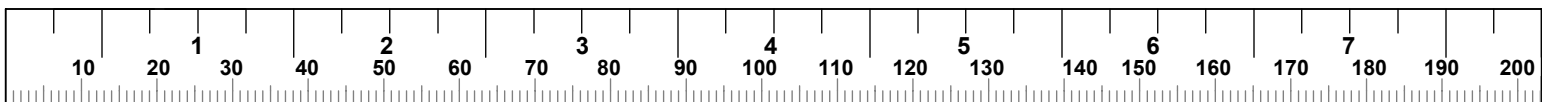

**STEP 10**

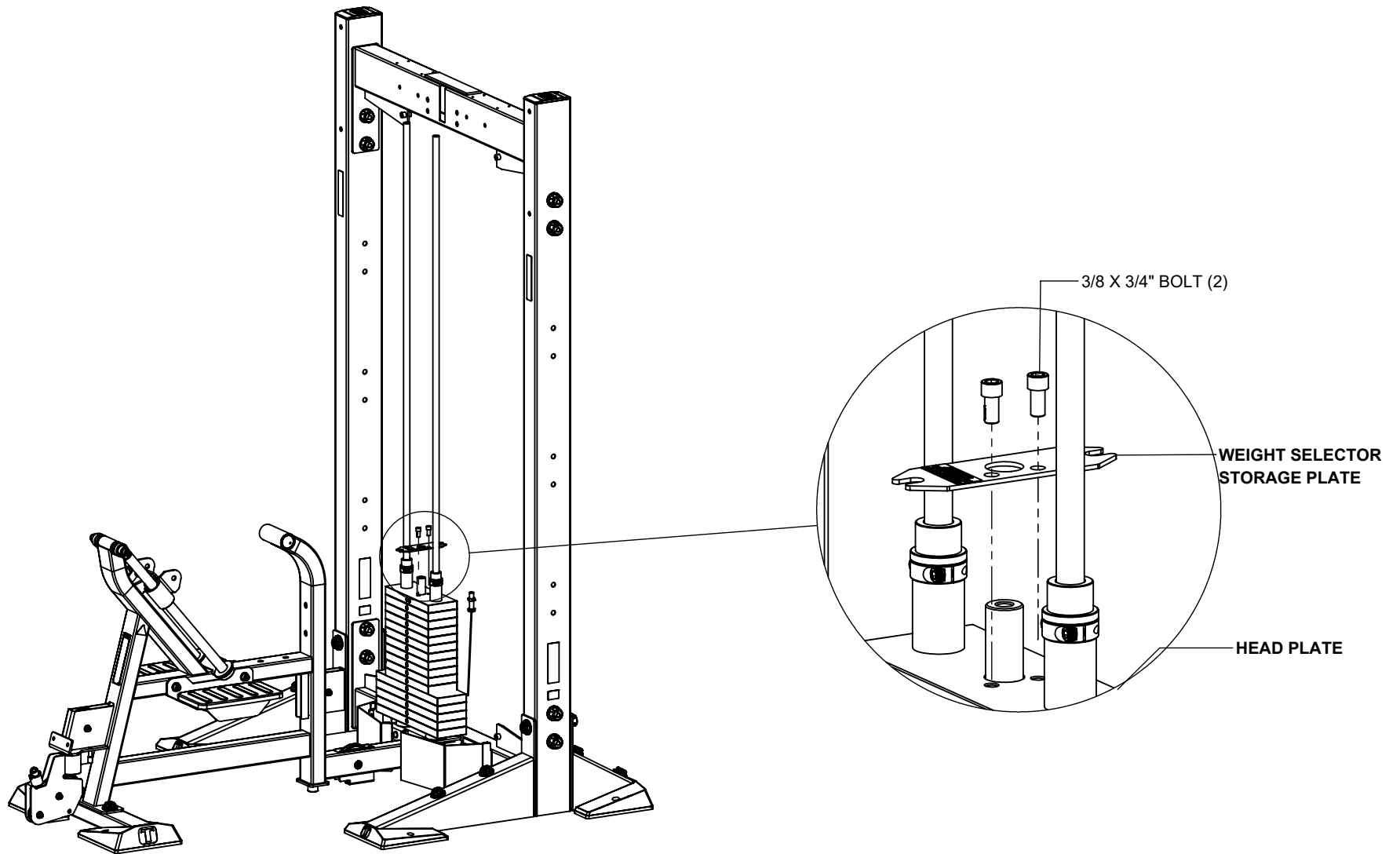

**NOTES:**

**SECURELY** tighten bolt connections in this step.

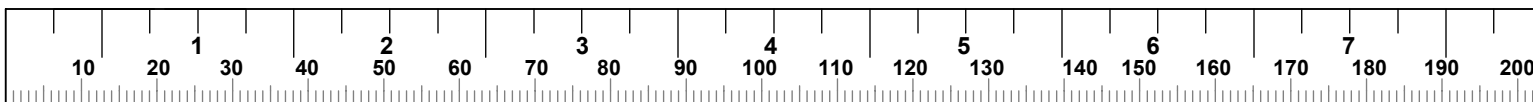

# STEP 11

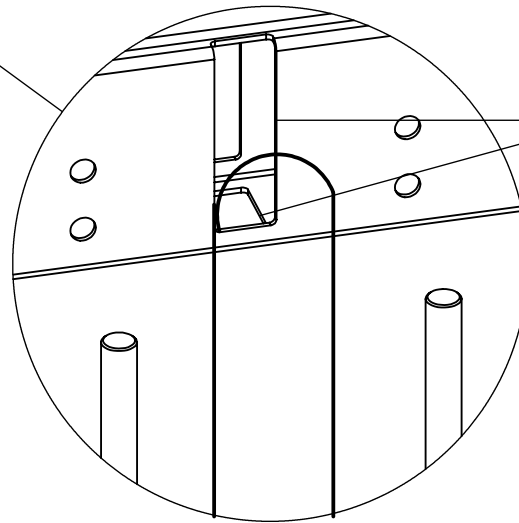
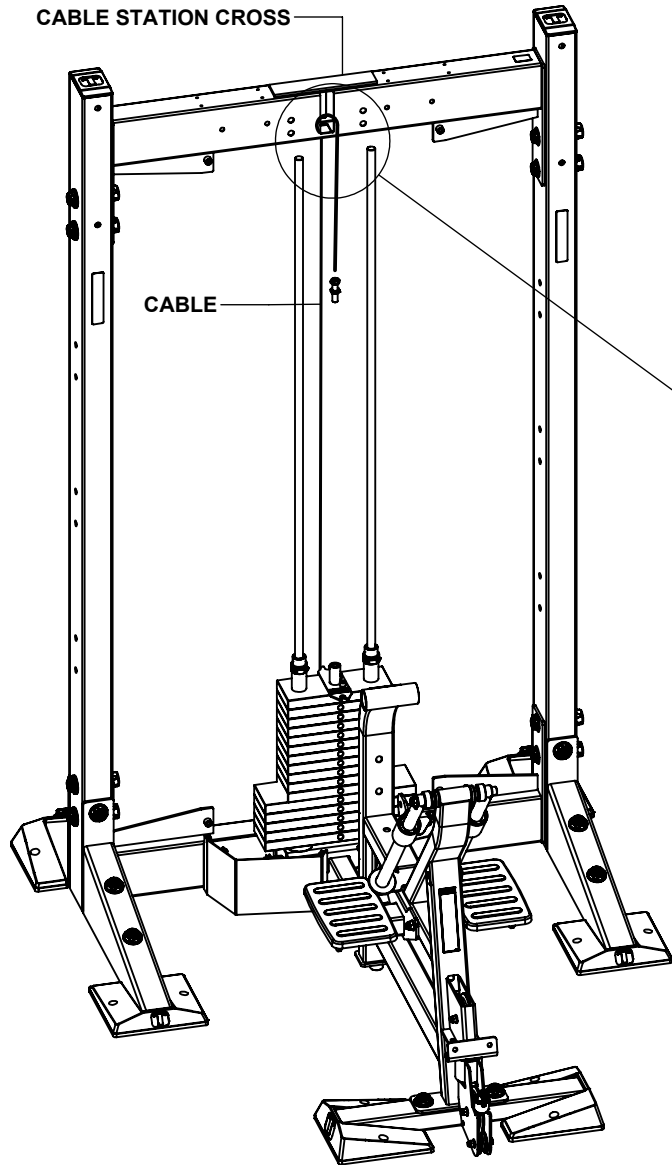

**NOTE:**  
BEFORE ASSEMBLING THE TOP BOOM,  
ROUTE THE CABLE UP THROUGH THE  
BOTTOM SLOT AND OUT THE FRONT  
SLOT OF THE TOP BOOM SUPPORT AS  
SHOWNT

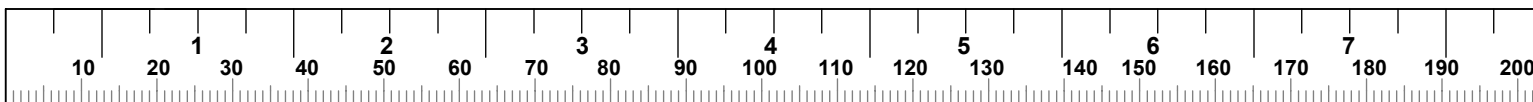

## STEP 12

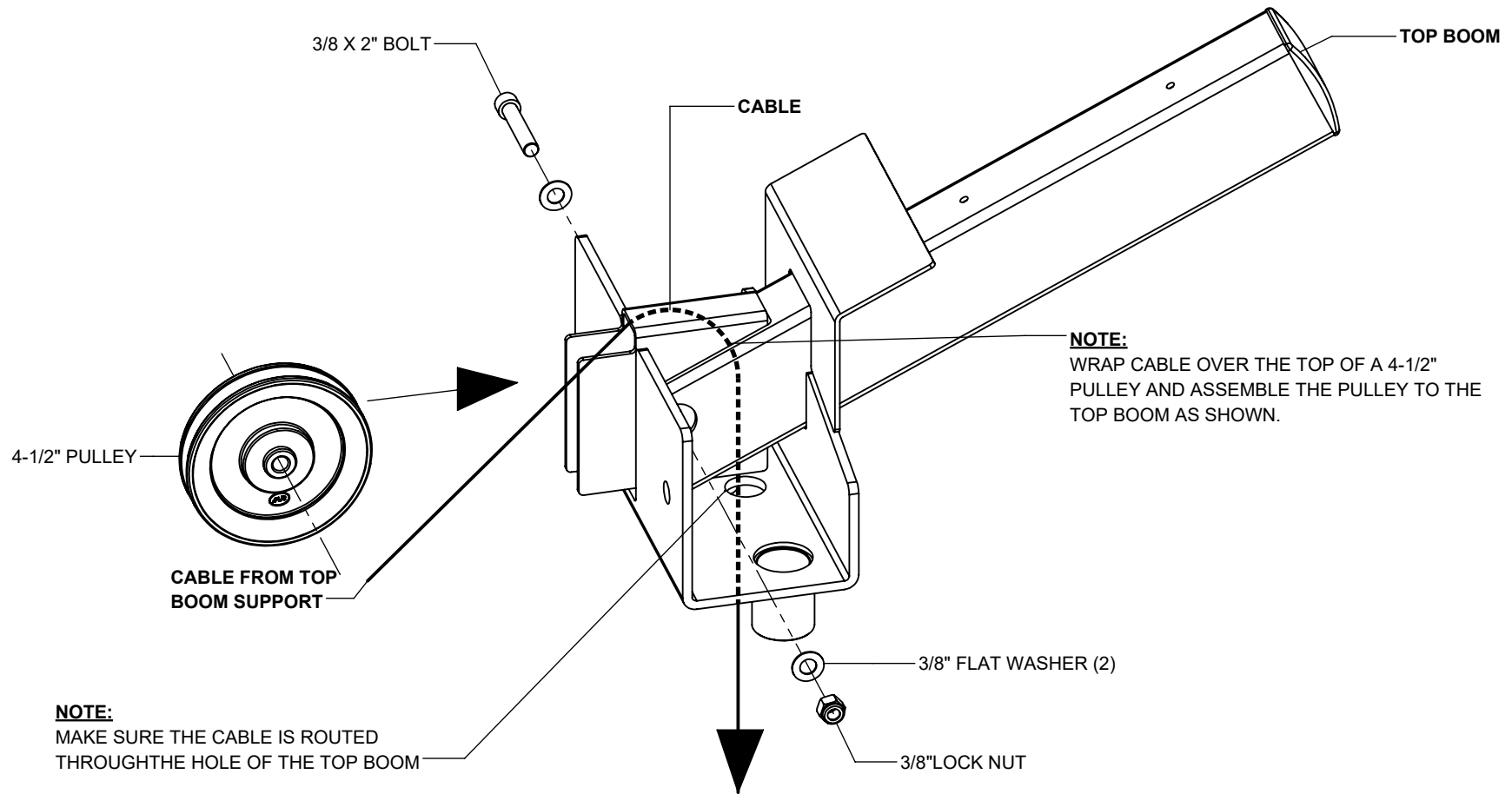

### **NOTES:**

**SECURELY** tighten bolt connections in this step.

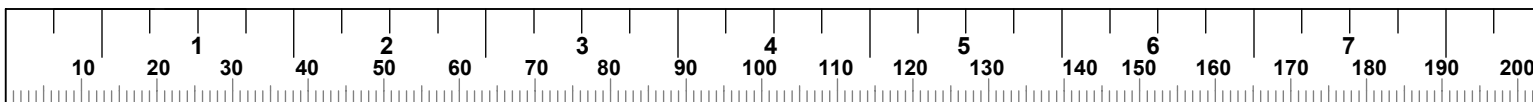

# STEP 13

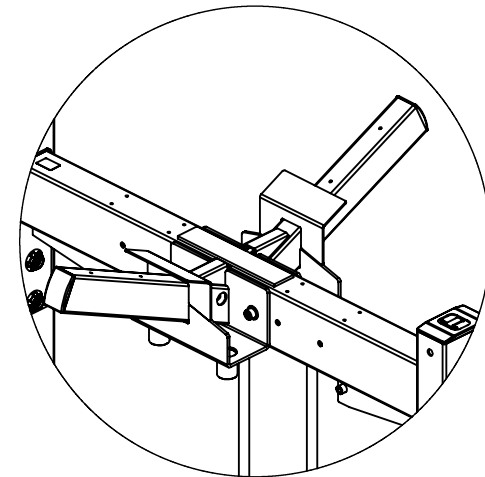
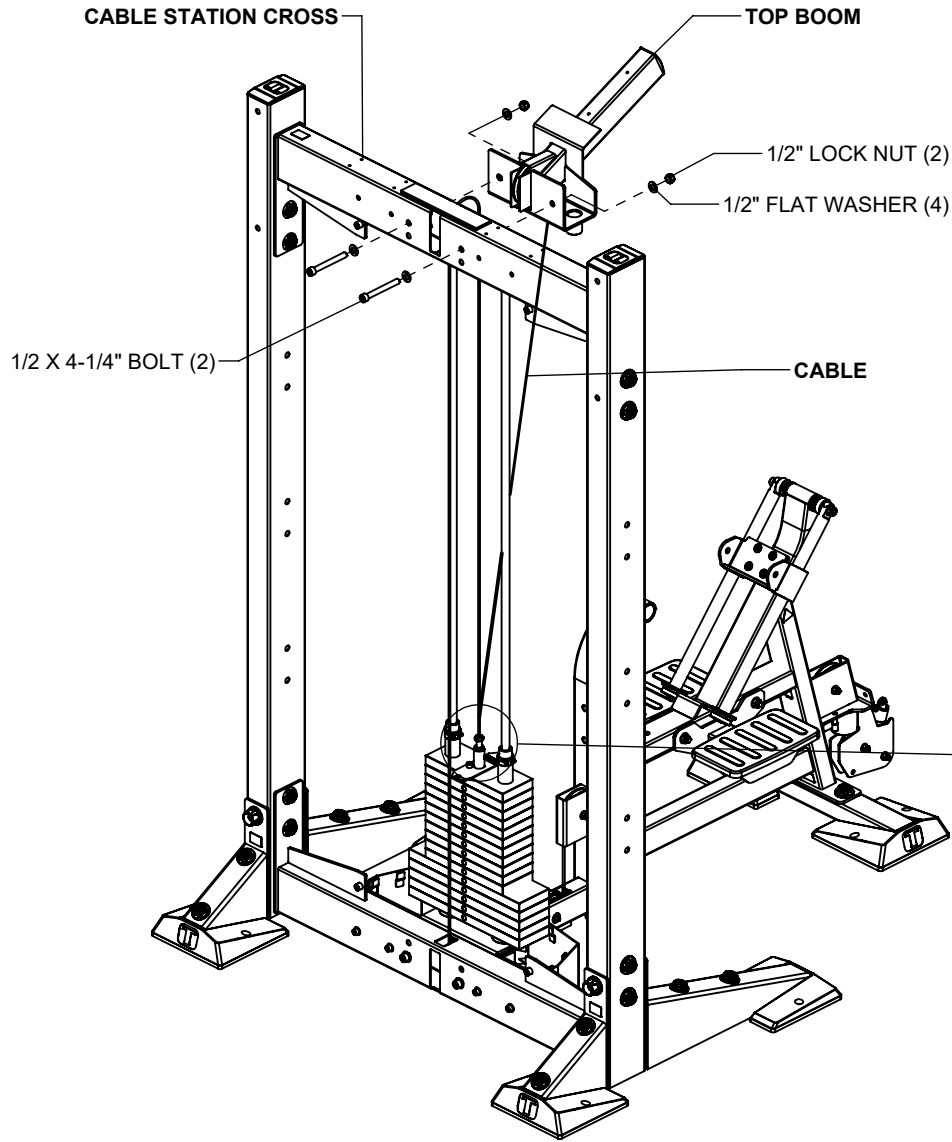

**NOTE:**  
IF ASSEMBLING CABLE STATIONS BACK TO BACK, PLEASE NOTE THAT THEY SHARE THE SAME TOP BOOM SUPPORT AND HARDWARE AS SHOWN. BOTH ROW TOP BOOMS NEED TO BE ASSEMBLED SIMULTANEOUSLY

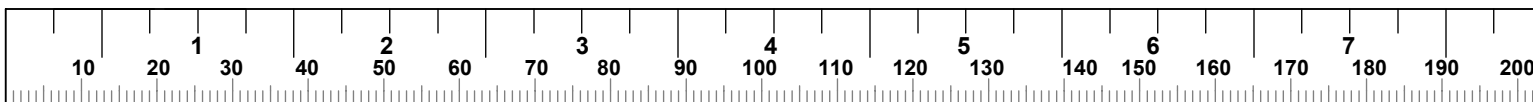
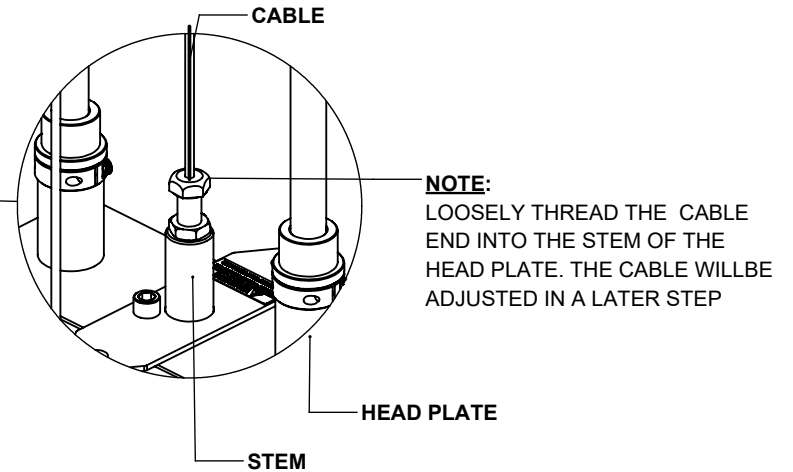

# STEP 14

**NOTE:**  
SECURELY TIGHTEN THESE BOLTS

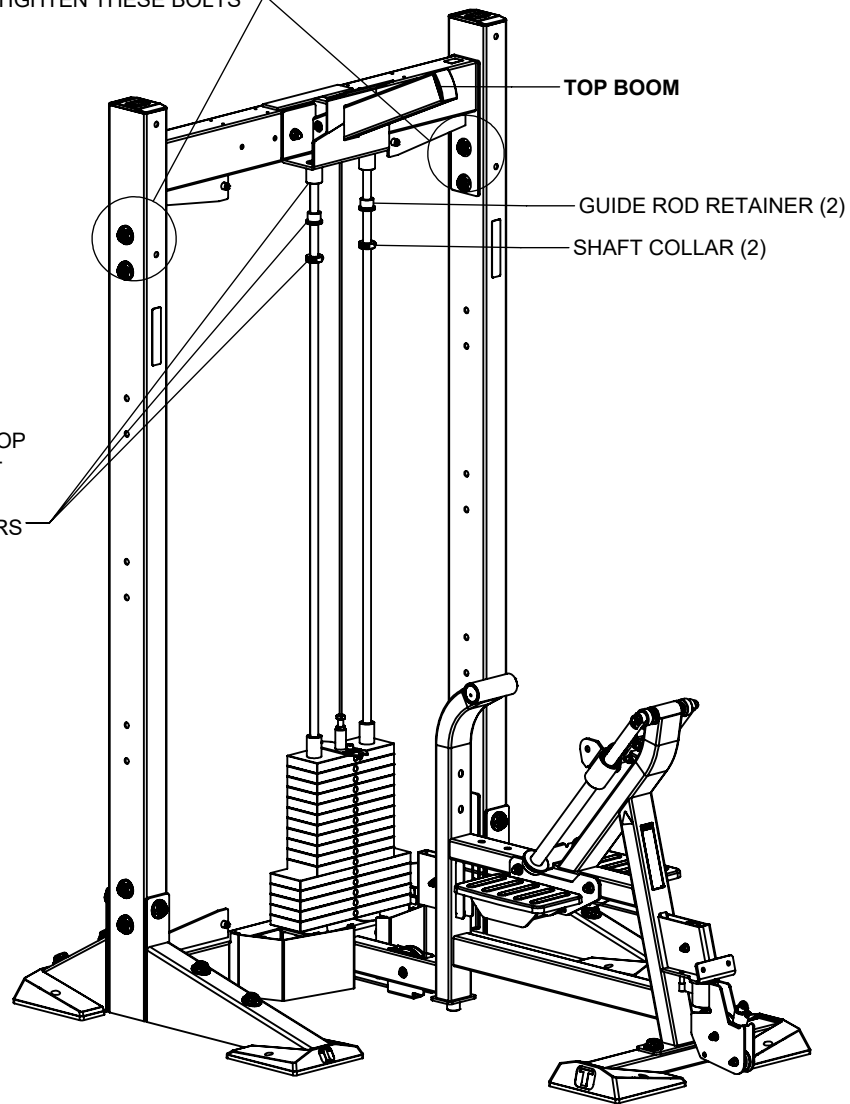

**NOTE:**  
SLIDE GUIDE ROD RETAINERS UP INSIDE TOP BOOM. SLIDE SHAFT COLLARS UP AGAINST GUIDE ROD RETAINERS AND **SECURELY** TIGHTEN BOTH SCREWS OF SHAFT COLLARS

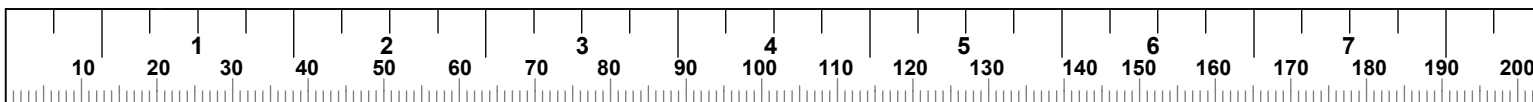

## STEP 15

### NOTE 1:

THREAD THE CABLE END INTO THE STEM OF THE HEAD PLATE UNTIL THE HOUSING IS APPROXIMATELY 1/4" AWAY FROM THE SWIVEL PULLEY, THEN SECURELY TIGHTEN THE JAM NUT. SEE NOTE 2.

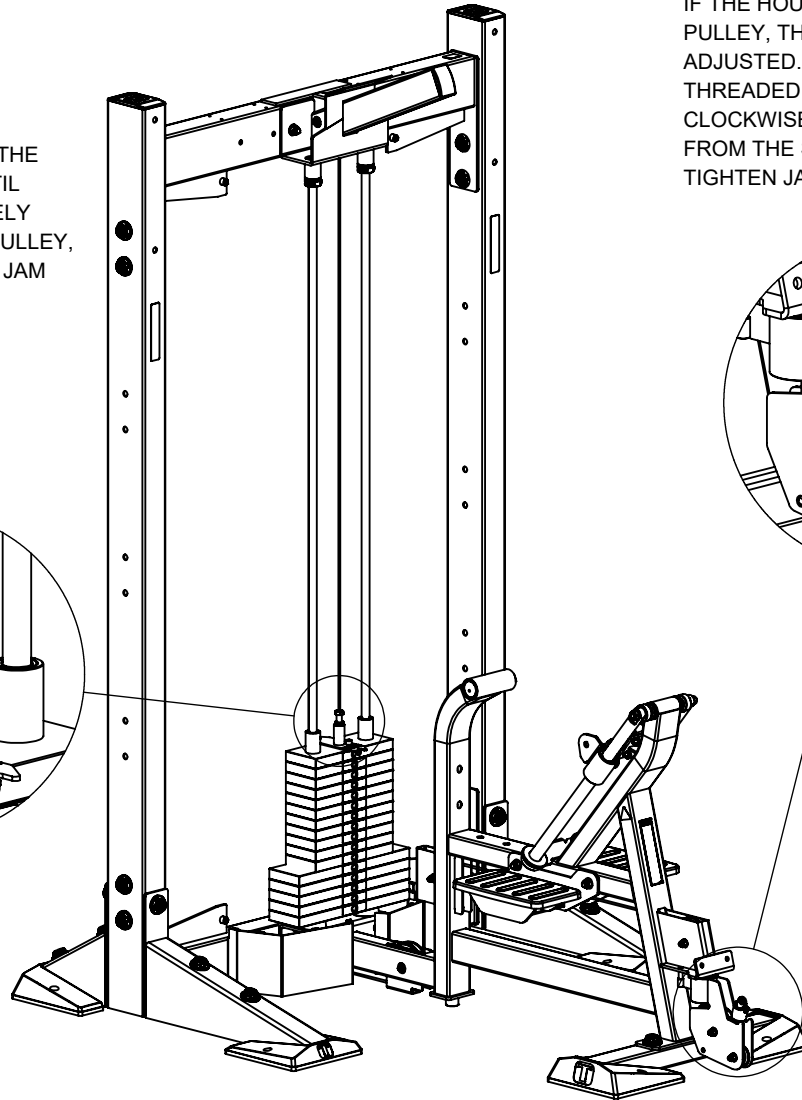

### NOTE 2:

THE HOUSING ON THE CABLE SHOULD BE AT LEAST 1/4" AWAY FROM THE SWIVEL PULLEY. IF THE HOUSING IS TOUCHING THE SWIVEL PULLEY, THEN THE CABLE NEEDS TO BE ADJUSTED. LOOSEN JAM NUT AND TURN THE THREADED END OF THE CABLE COUNTER CLOCKWISE UNTIL THE HOUSING IS 1/4" AWAY FROM THE SWIVEL PULLEY. SECURELY TIGHTEN JAM NUT.

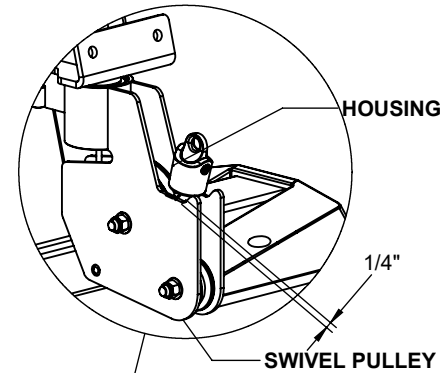

### NOTE:

ATTACH THE WEIGHT STACK LABELS TO THE WEIGHT STACK STARTING WITH THE HEAD PLATE

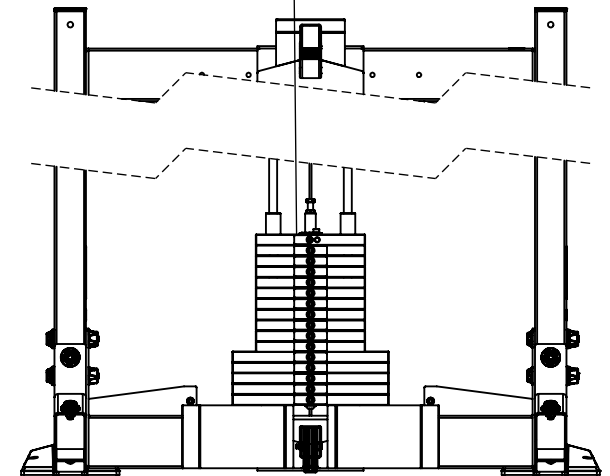

STORAGE FOR WEIGHT  
STACK SELECTOR PIN

CABLE END

JAM NUT

STEM

HEAD PLATE

### NOTES:

**SECURELY** tighten bolt connections in this step.

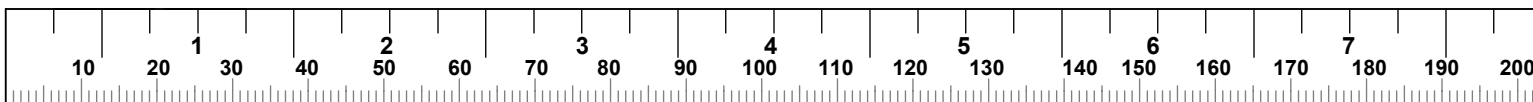

# STEP 16

**NOTE:**  
MAKE SURE SHROUD IS SEATED BETWEEN THE SHROUD SUPPORT AND 4 TABS AS SHOWN.

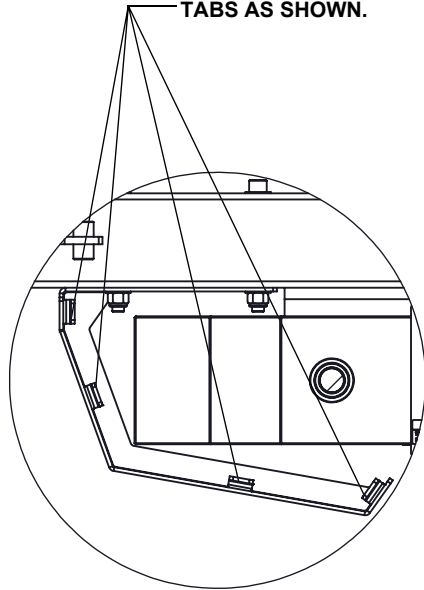

TOP VIEW LEFT

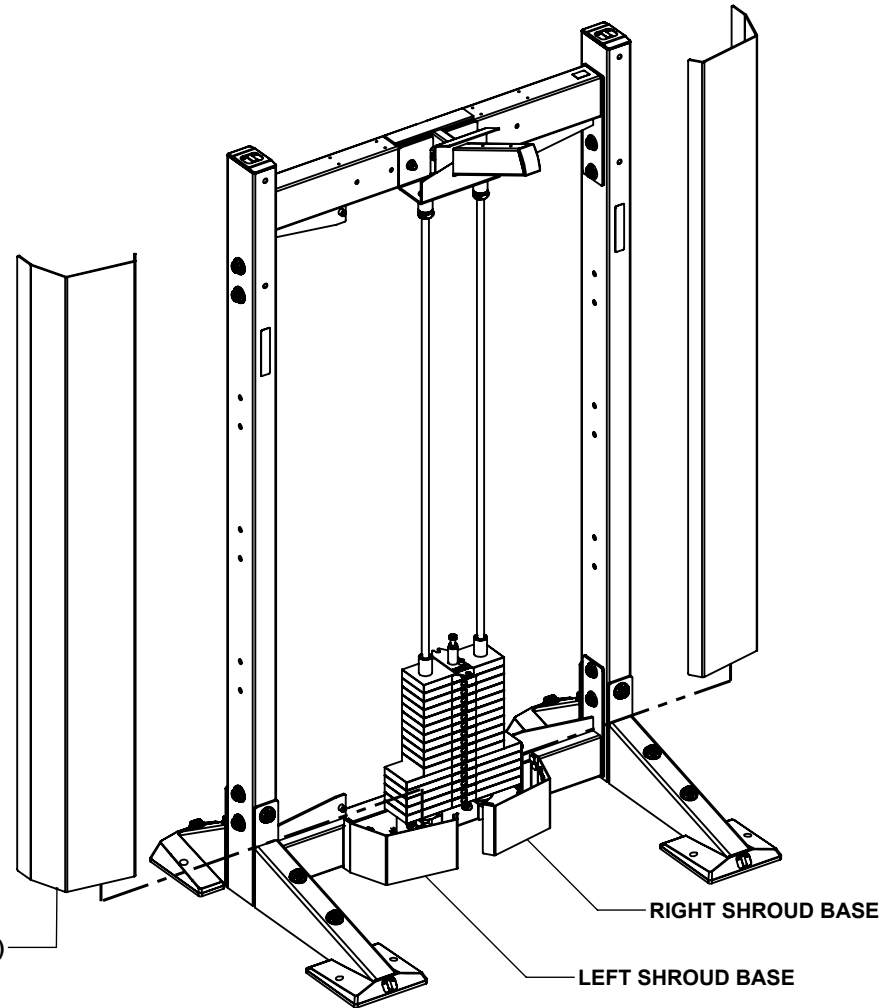

**NOTE:**  
MAKE SURE SHROUD IS SEATED BETWEEN THE SHROUD SUPPORT AND 4 TABS AS SHOWN.

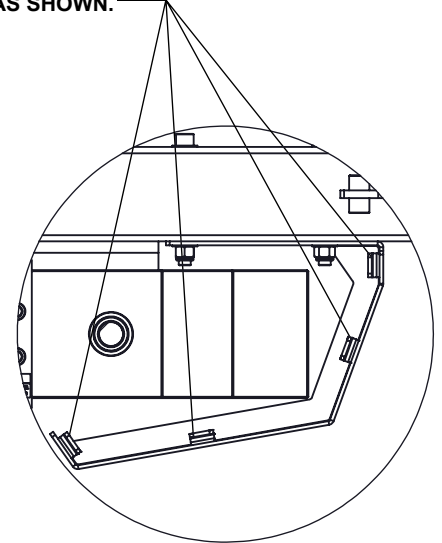

TOP VIEW RIGHT

## NOTES:

BACK EXTENSION BASE and CABLE have been hidden for illustration clarity.

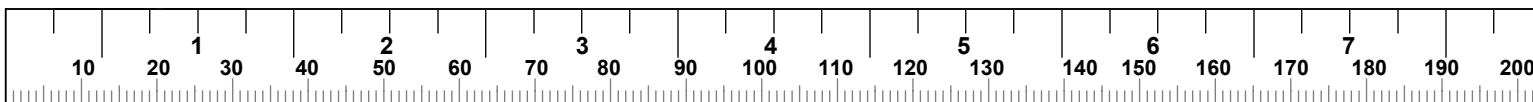

# STEP 17

**NOTE:**

MAKE SURE INTERNAL GROOVES OF THE TOP CAP FIT DOWN OVER THE TOP EDGES OF BOTH FRONT SHROUDS.

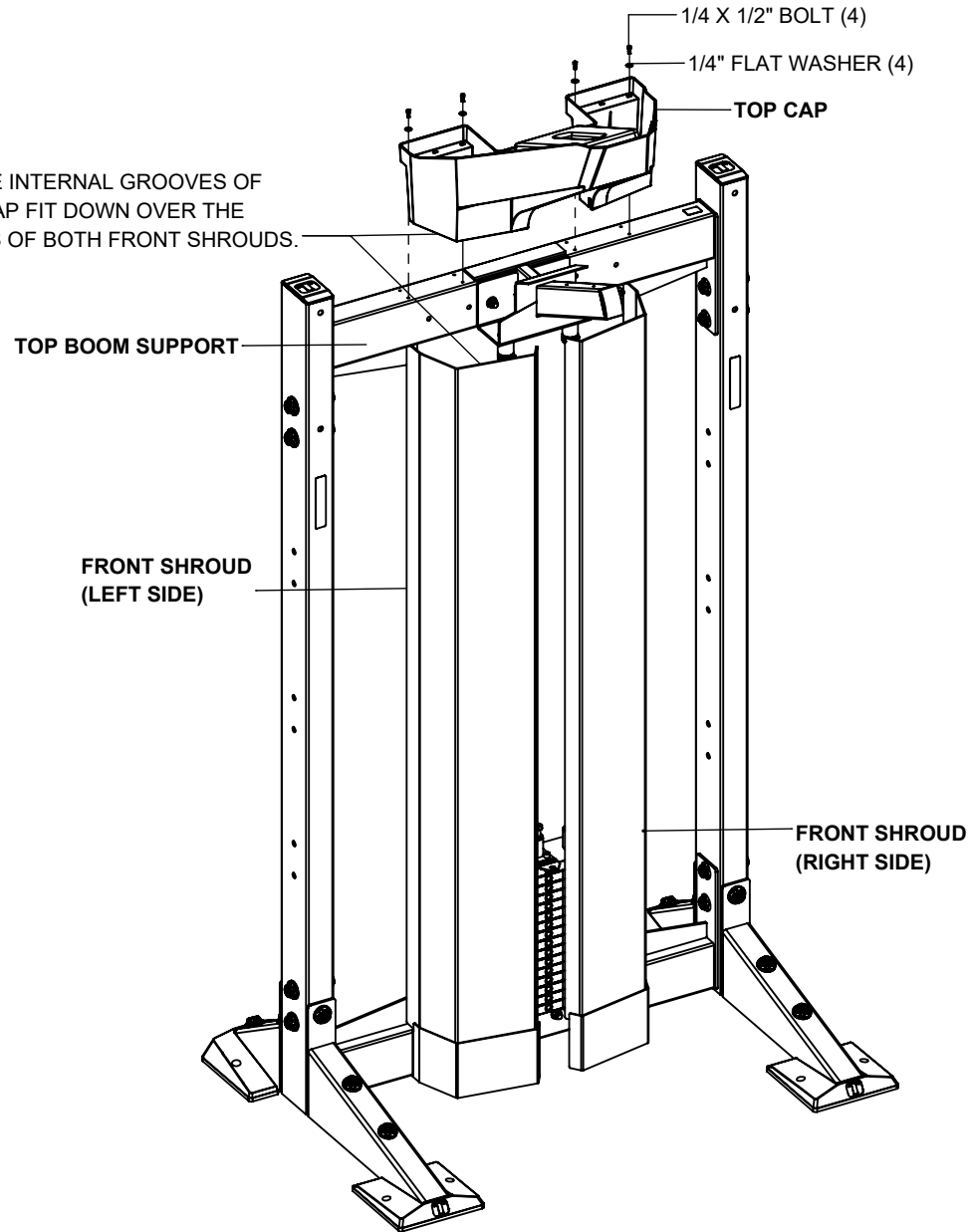

**NOTES:**

**LOOSELY** tighten bolt connections in this step.

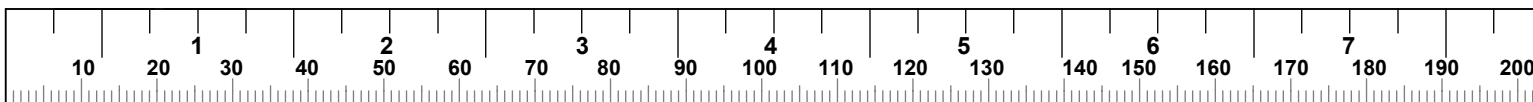

## STEP 18

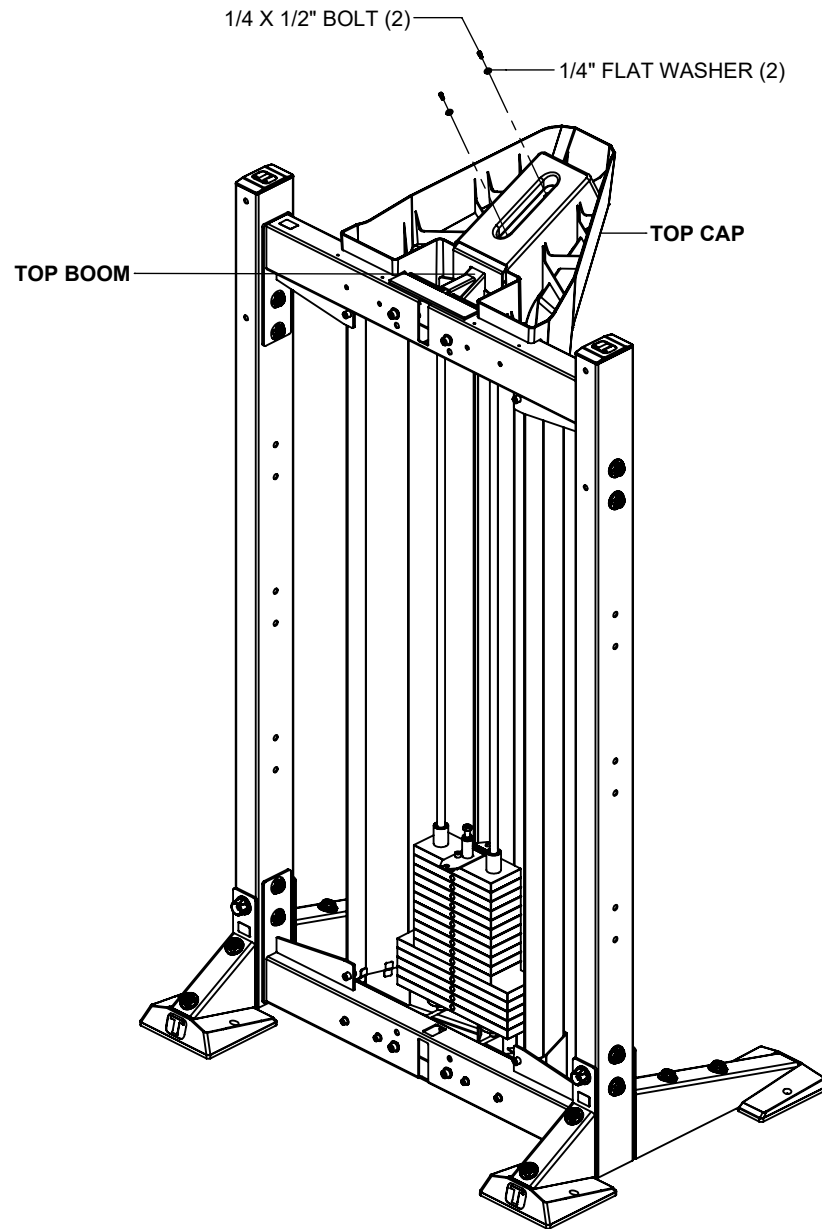

### NOTES:

**SECURELY** tighten bolt connections in this step, and previous step.

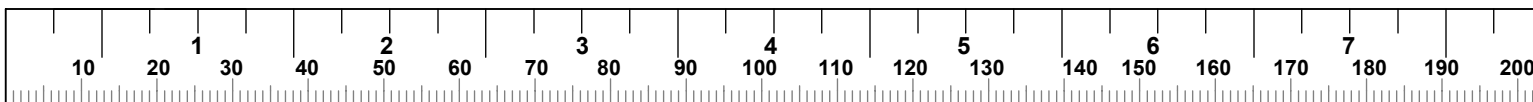

# STEP 19

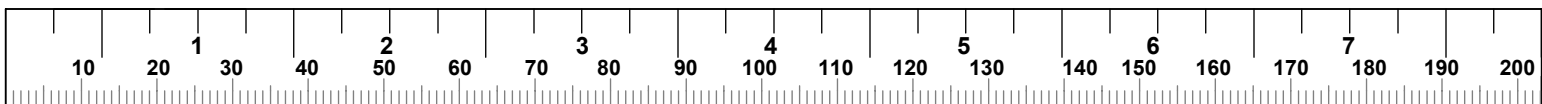
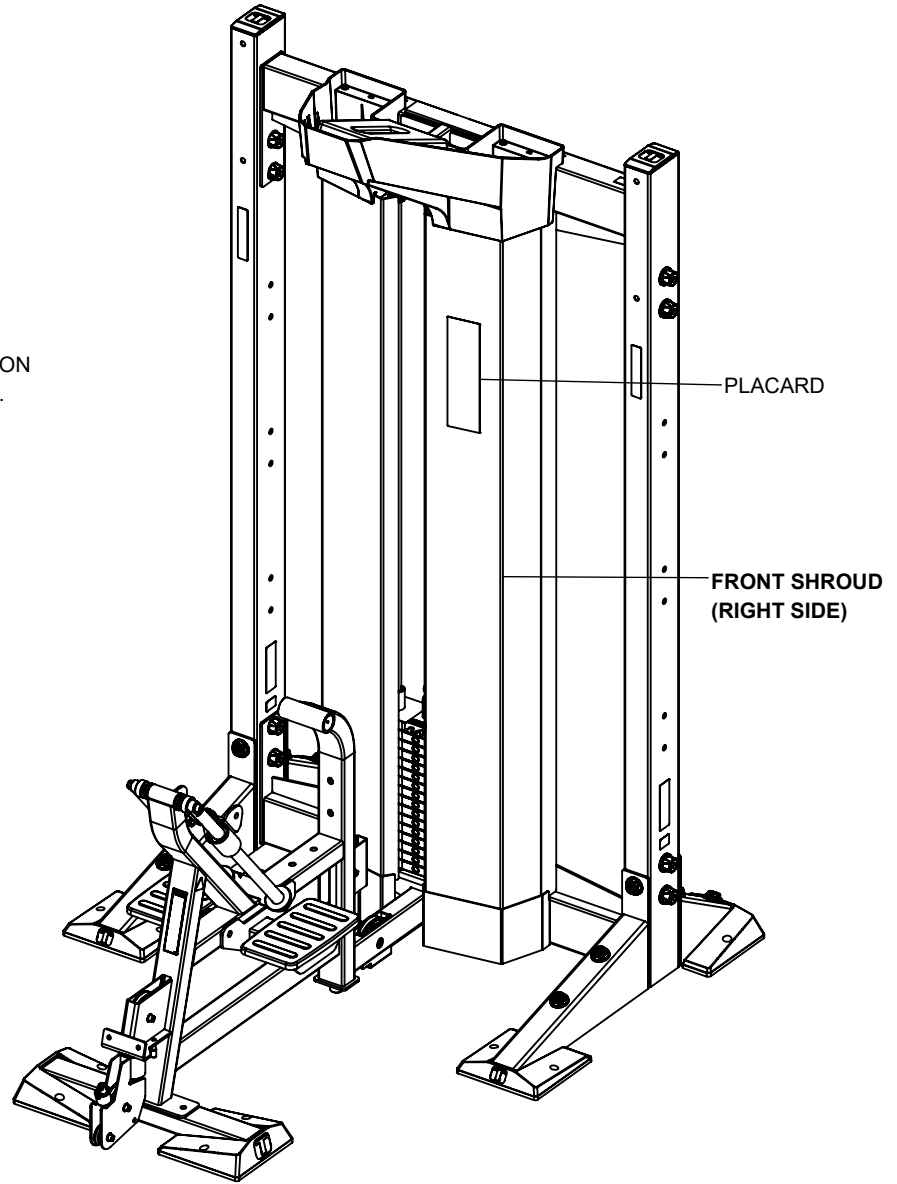
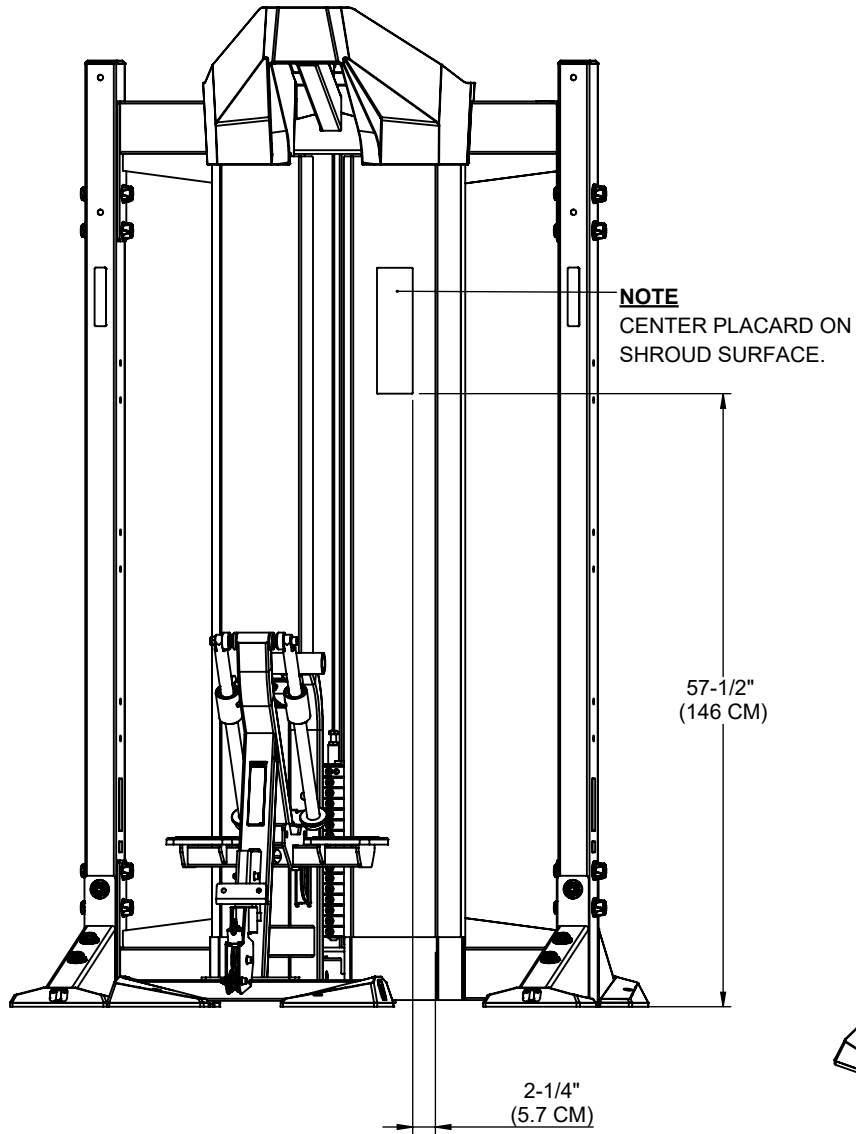

**STEP 20**

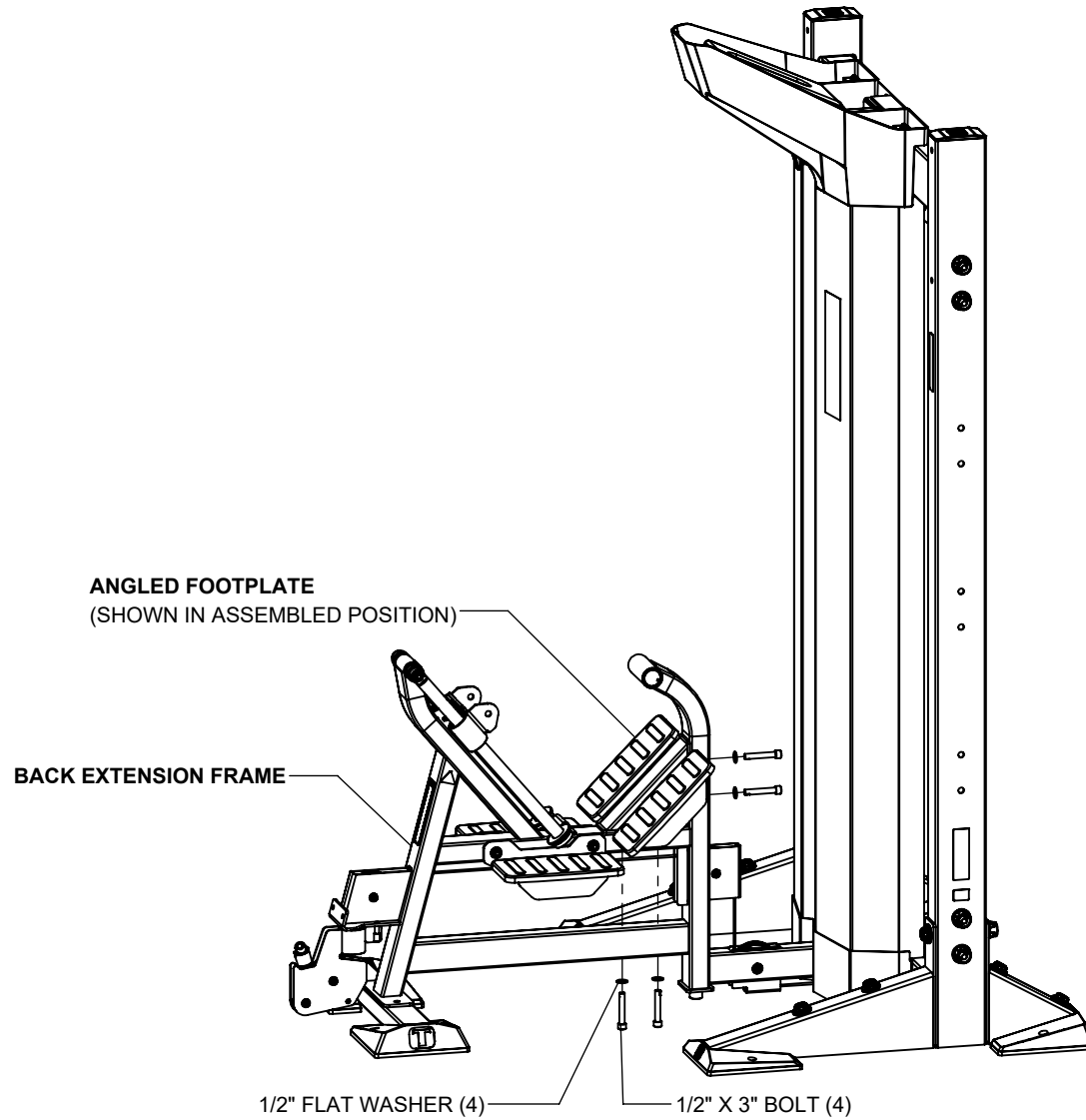

**NOTES:**

**SECURELY** tighten bolt connections in this step.

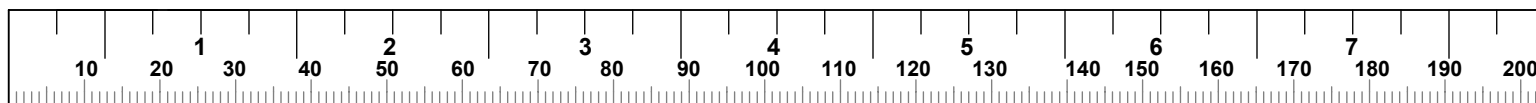

**STEP 21A & 21B**

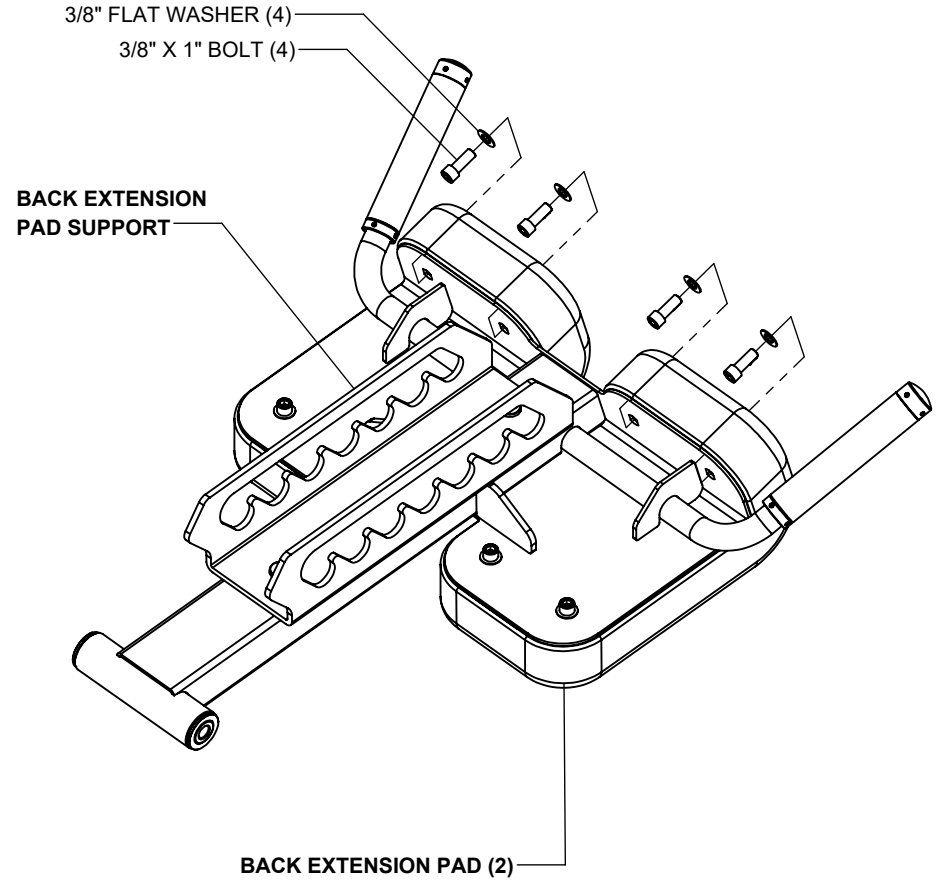
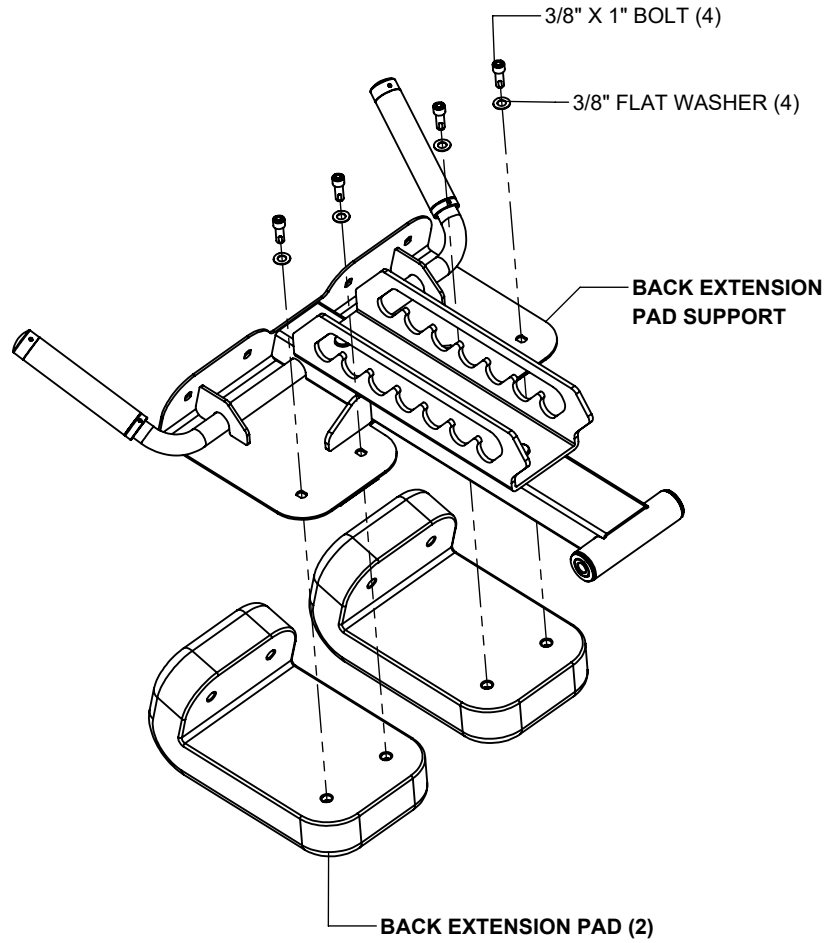

**NOTES:**

**SECURELY** tighten bolt connections in this step.

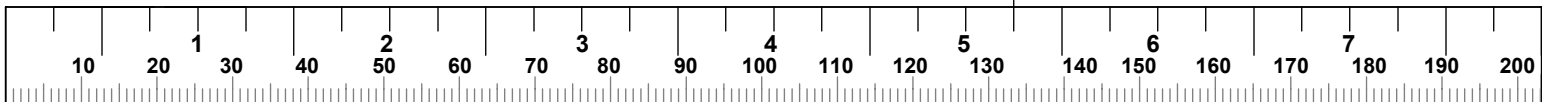

## STEP 22

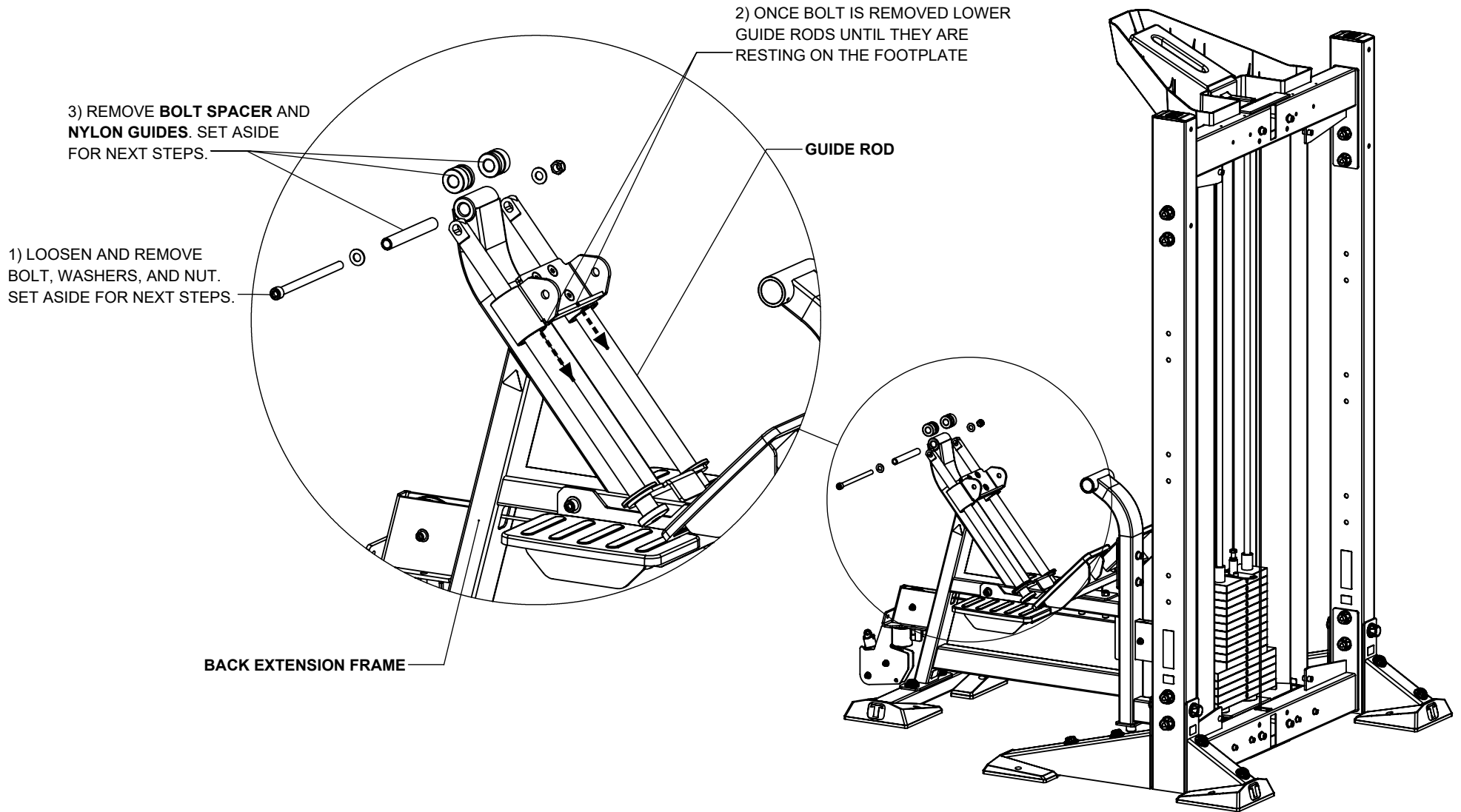

### NOTES:

**SECURELY** tighten bolt connections in this step.

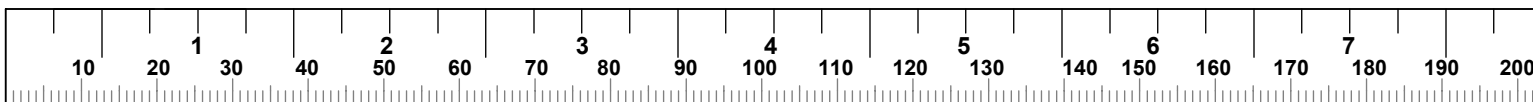

## STEP 23

1) LOOSELY POSITION THE **NYLON GUIDES** IN ADJUSTMENT RACK OF THE **PAD SUPPORT**. NOTE THAT THE THICKER SIDE OF THE **NYLON GUIDE** GOES ON THE OUTSIDE OF THE BRACKET.

2) WHILE HOLDING THE GUIDES IN PLACE, SLIDE ASSEMBLY ONTO THE **BACK EXTENSION FRAME** BETWEEN THE TWO **GUIDE RODS**.

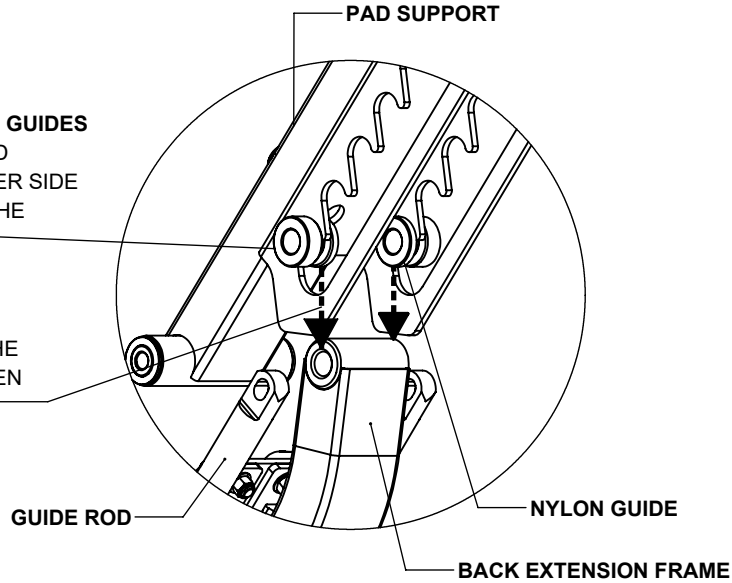

2) ALIGN HOLES OF THE **NYLON GUIDES** WITH THE TUBE IN THE FRAME. INSERT THE **BOLT SPACER** AND CENTER.

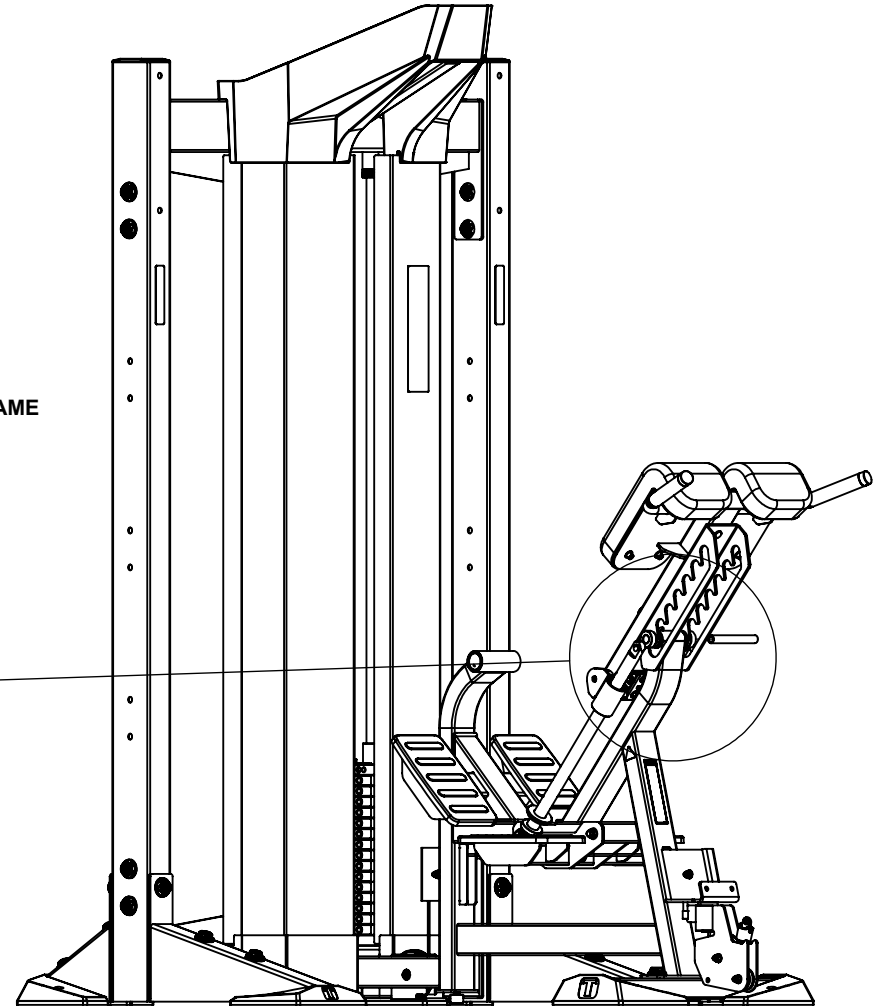
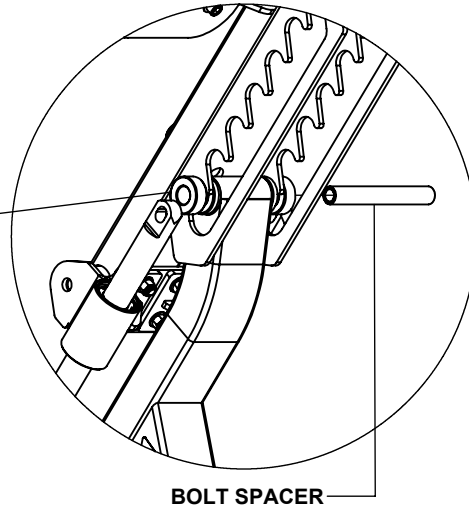

## NOTES:

Reuse hardware from previous steps.

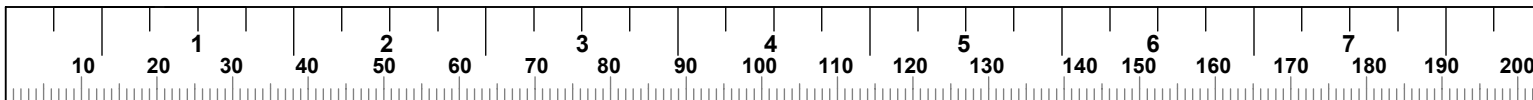

# STEP 24

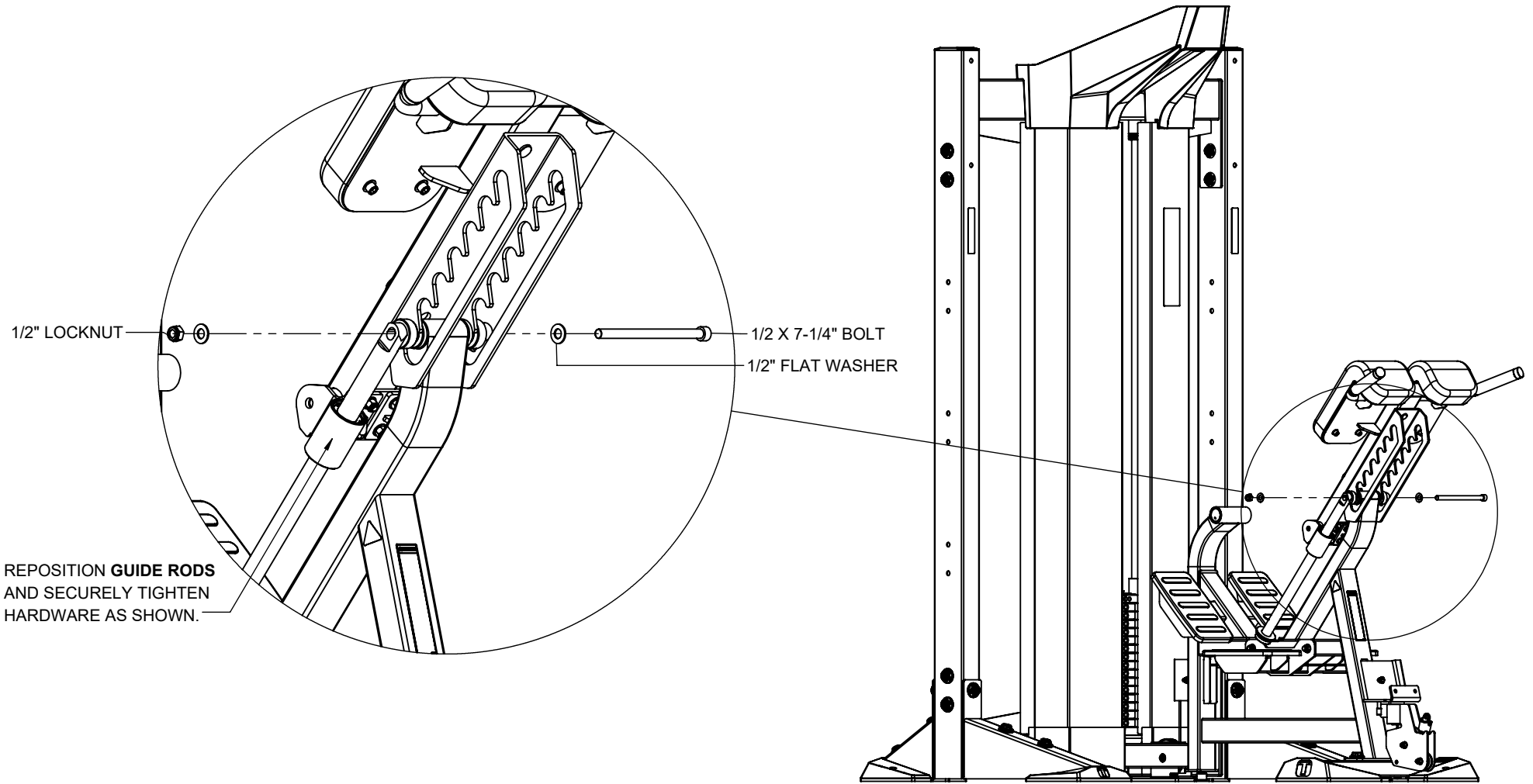

## NOTES:

**SECURELY** tighten bolt connections in this step.

Reuse hardware from previous steps.

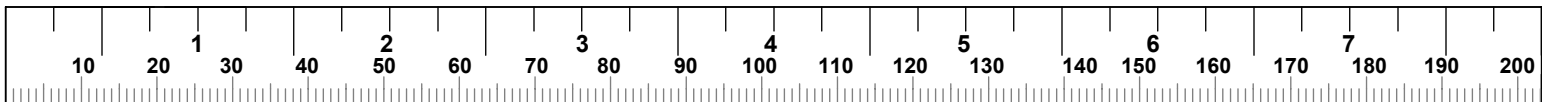

# STEP 25

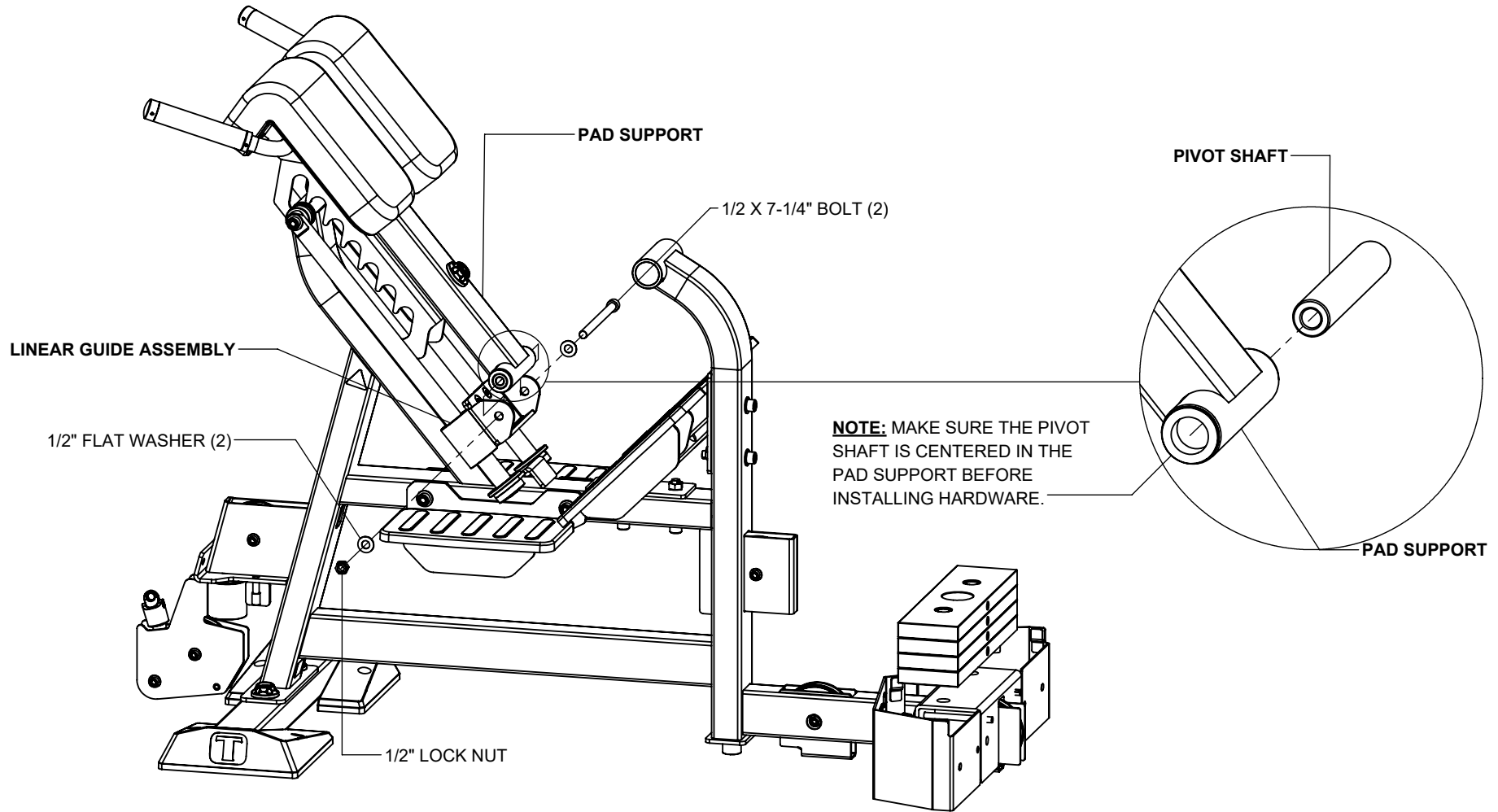

## NOTES:

**SECURELY** tighten bolt connections in this step.

Parts are hidden for assembly clarity.

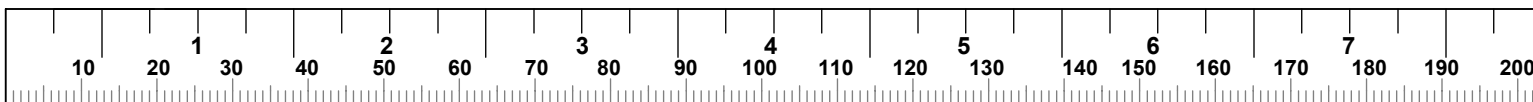

# STEP 26

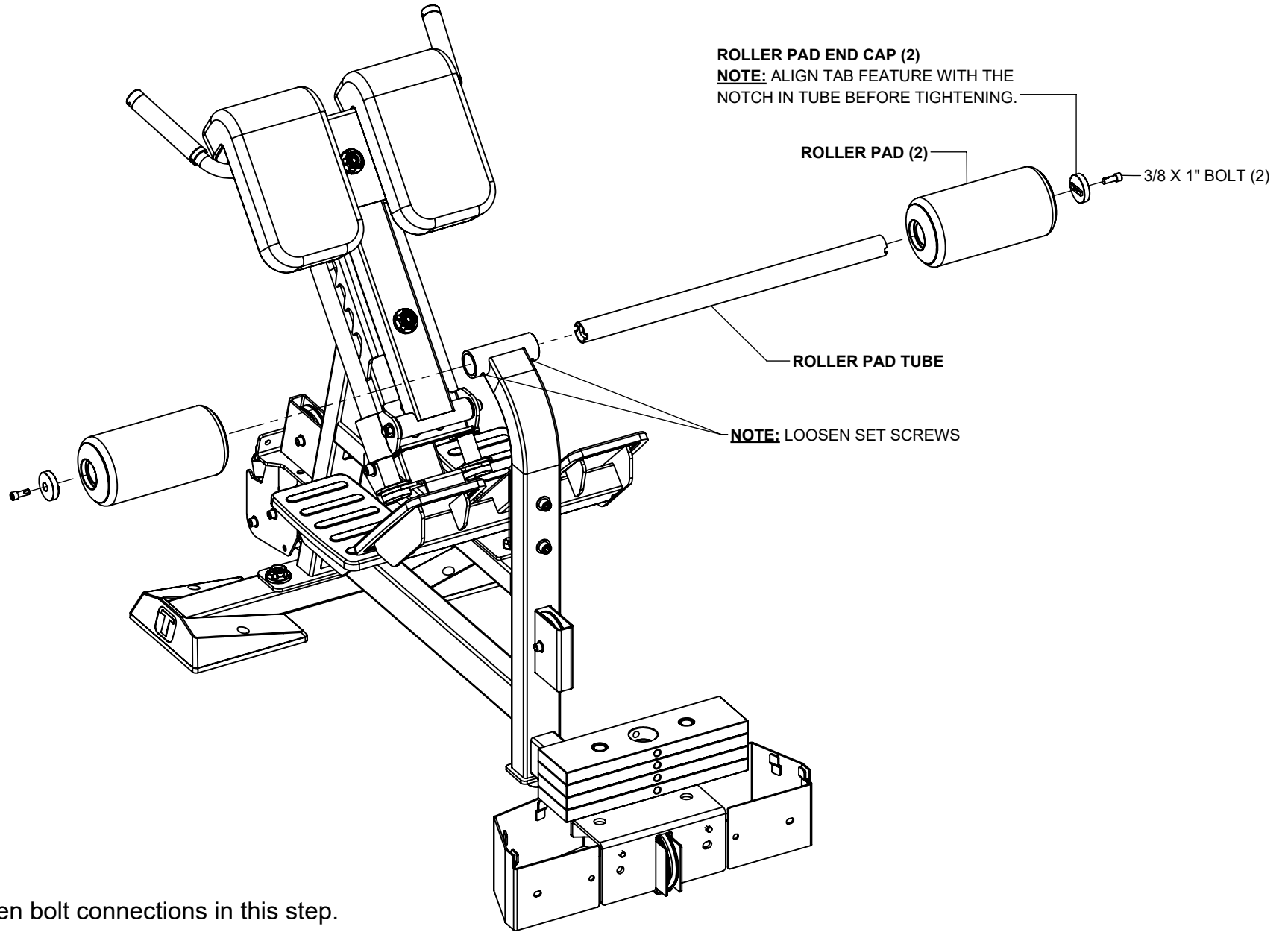

## NOTES:

**LOOSELY** tighten bolt connections in this step.

Parts are hidden for assembly clarity.

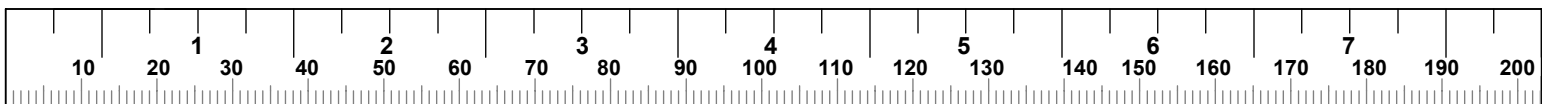

## STEP 27

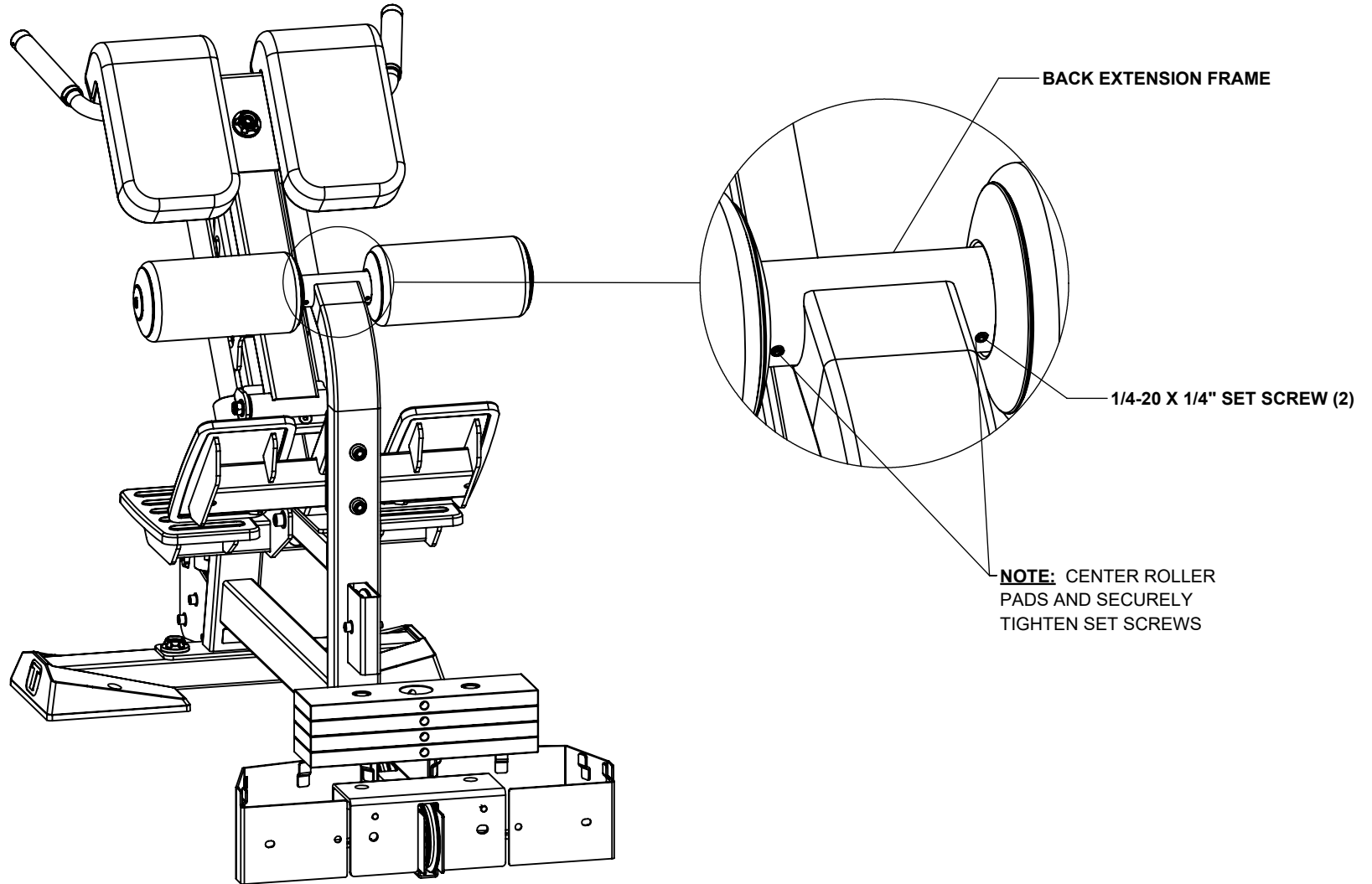

### NOTES:

**SECURELY** tighten bolt connections in this step and previous steps.

Parts are hidden for assembly clarity.

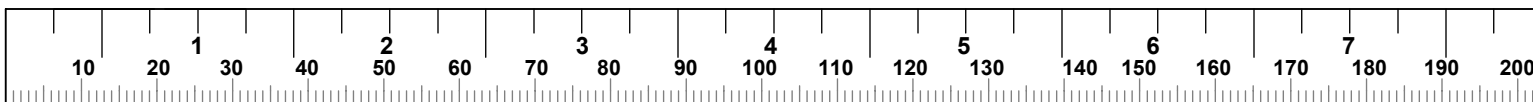

**STEP 28**

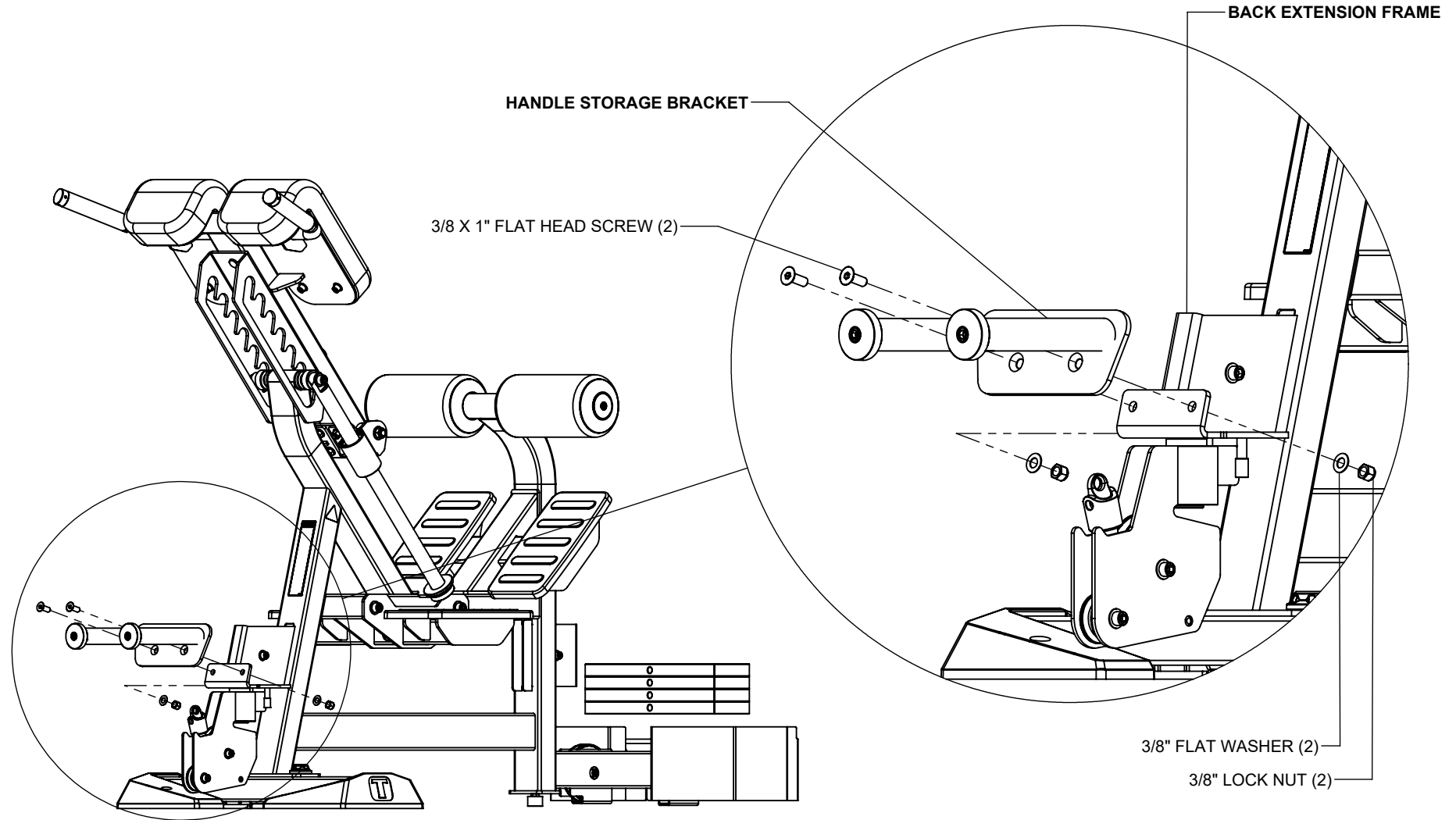

**NOTES:**

**SECURELY** tighten bolt connections in this step and previous steps.

Parts are hidden for assembly clarity.

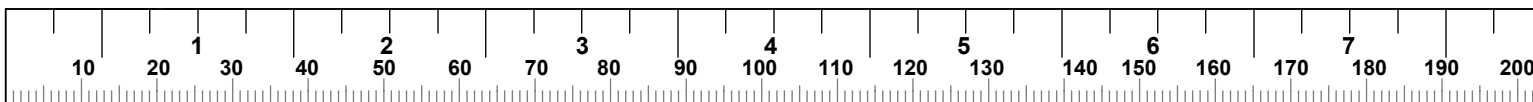

**STEP 29**

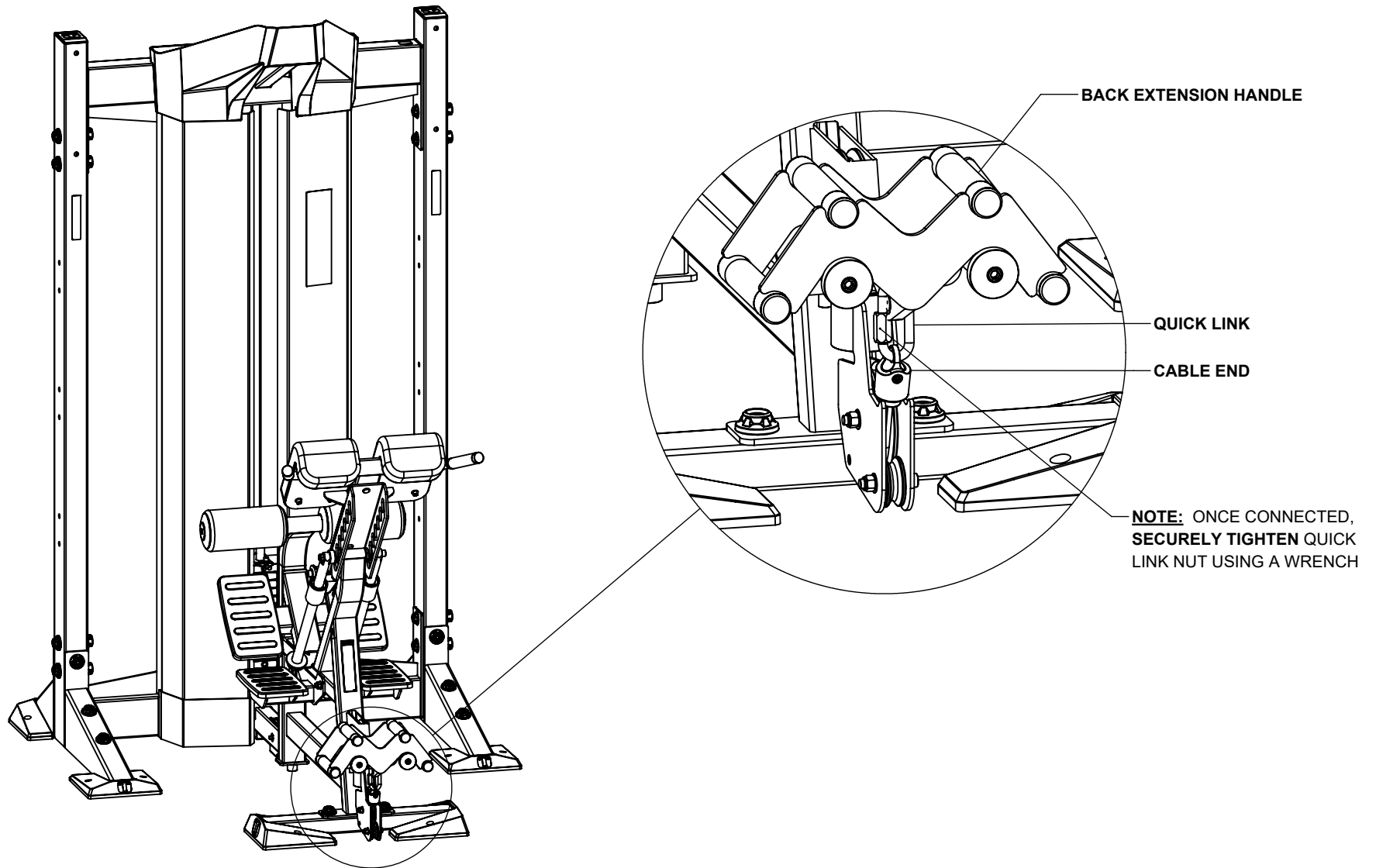

## STEP 30 (OPTIONAL REAR SHROUD)

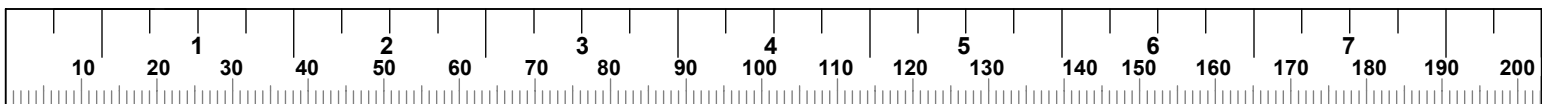
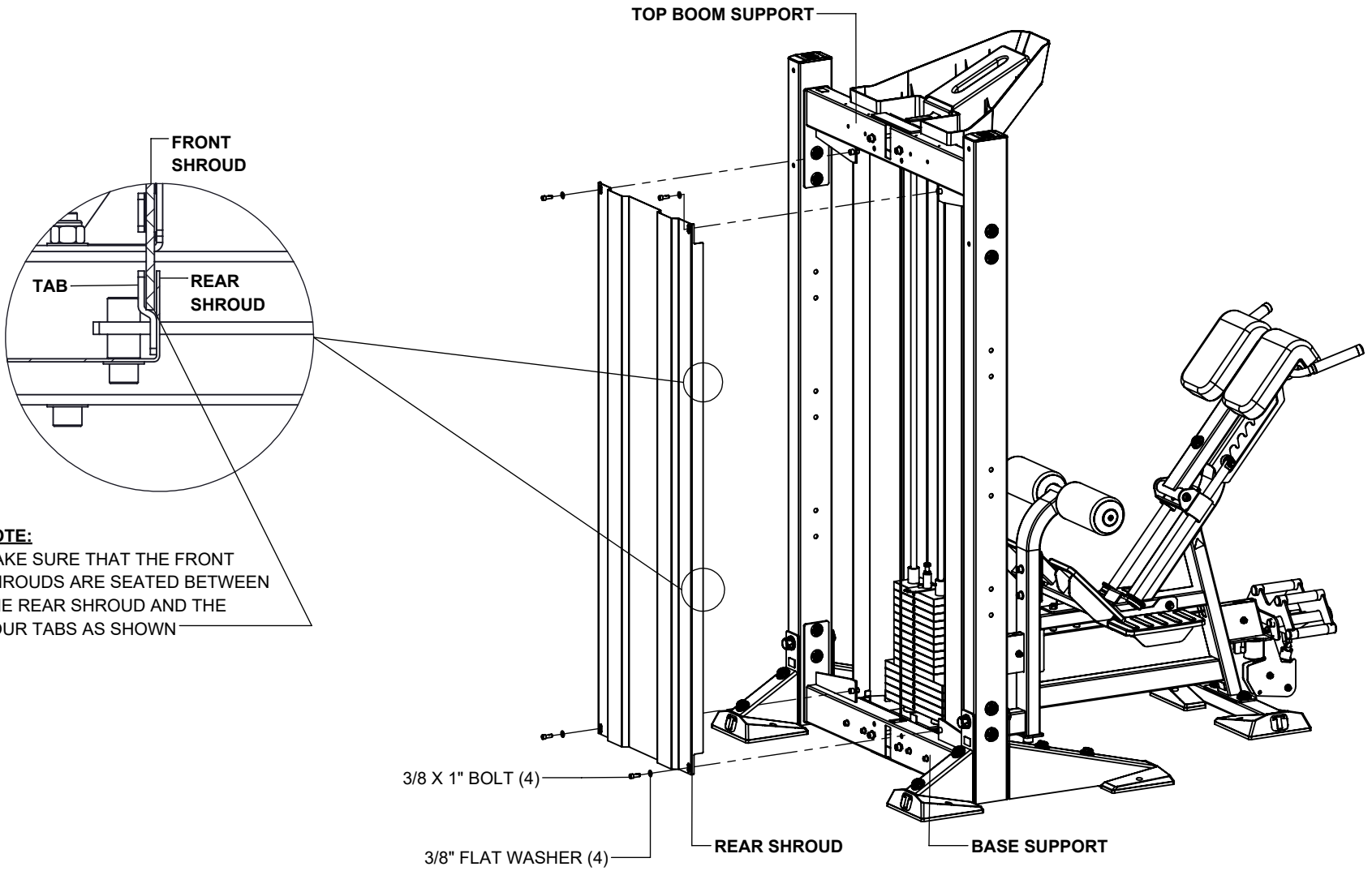

## FLOOR ANCHORING

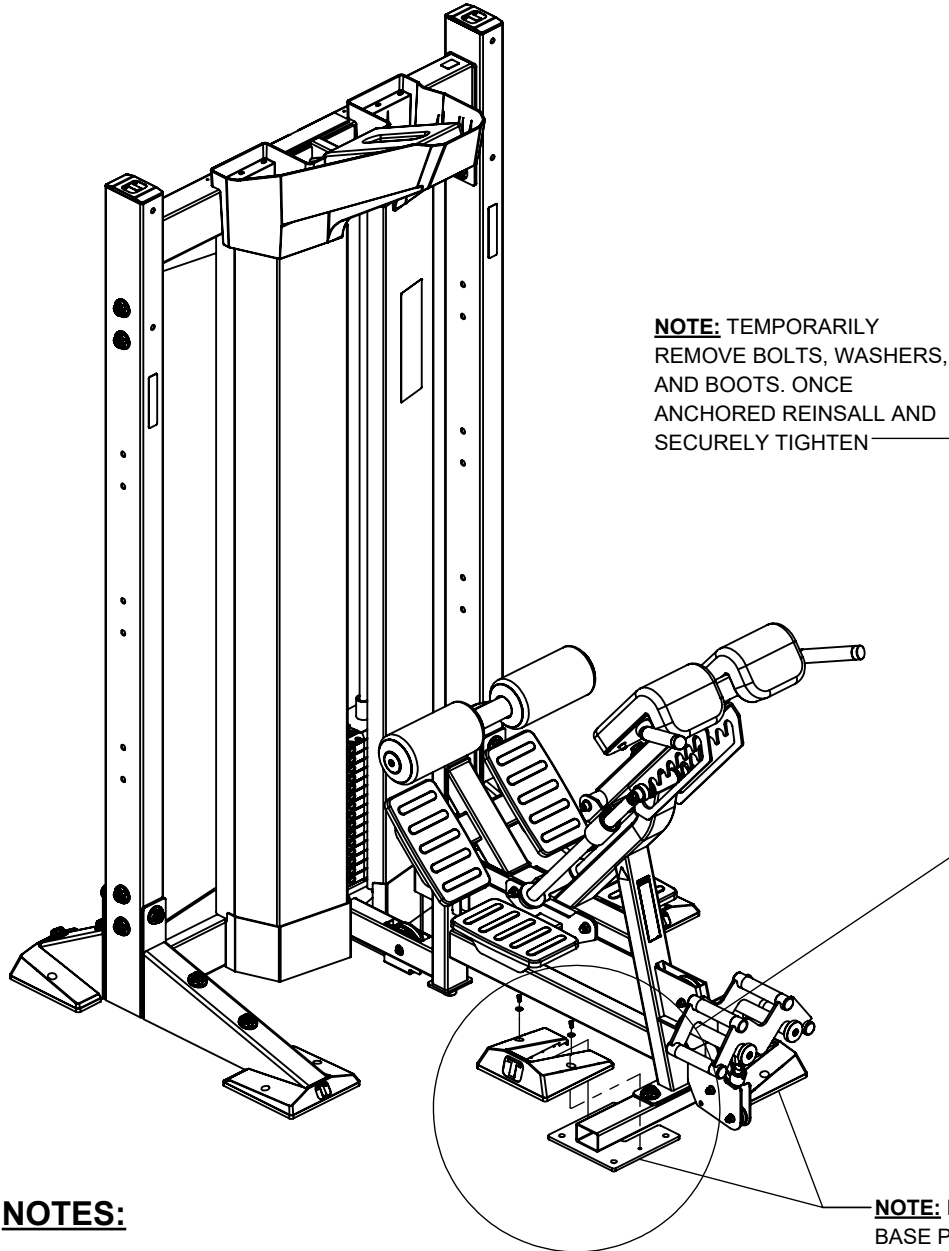

**NOTE:** TEMPORARILY REMOVE BOLTS, WASHERS, AND BOOTS. ONCE ANCHORED REINSALL AND SECURELY TIGHTEN

**ANCHOR HOLES.** BACK EXTENSION FRAME REQUIRES ANCHORING THE BASE TO THE FLOOR. MINIMUM TWO ANCHORS PER PLATE.

### **NOTES:**

Anchor system to the floor referencing X-CREATE ANCHORING INSTRUCTIONS which can be downloaded at [www.torquefitness.com/assembly-manuals](http://www.torquefitness.com/assembly-manuals)

### **WARNING!**

**ALL X-CREATE ARE REQUIRED TO BE ANCHORED TO THE FLOOR TO PREVENT ROCKING OR TIPPING DURING USE.**

**NOTE:** REPEAT FOR BOTH BASE PLATES

## ADJUSTMENT

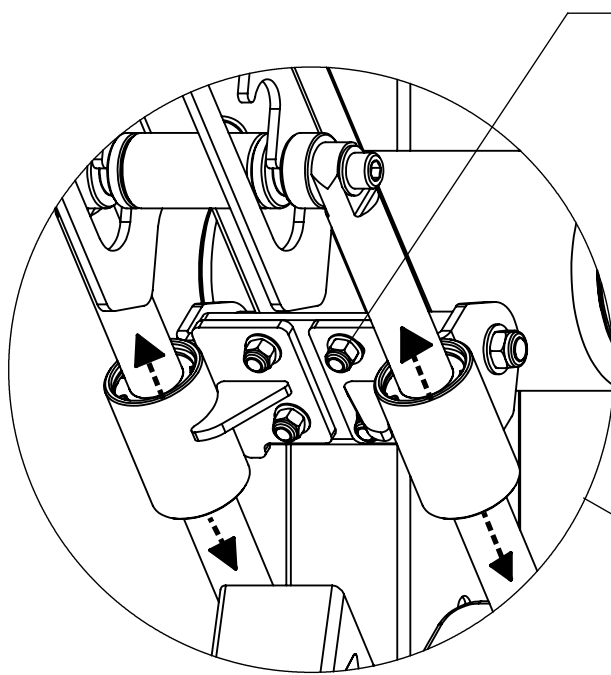

**NOTE:** IF THE ADJUSTMENT DOES NOT FEEL SMOOTH, THE LINEAR GUIDE MAY BE ADJUSTED. TO ADJUST LOOSEN THE 4 BOLTS SHOWN UNTIL THE GUIDE SLIDES FREELY ON THE GUIDE RODS AND SECURELY RETIGHTEN.

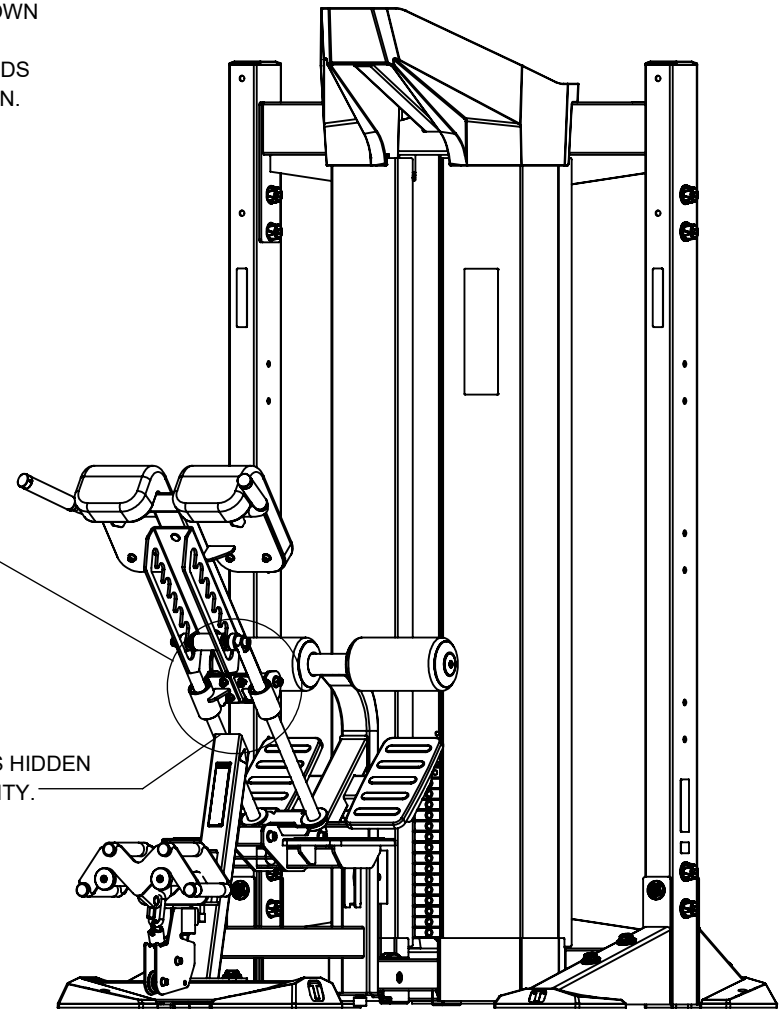

**NOTE:** FRAME TUBE IS HIDDEN FOR ASSEMBLY CLARITY.

## **MAINTENANCE**

**GUIDE RODS:** Clean and lubricate with a silicone or teflon based lubricant

**INSPECTION:** Once a month, check for loose bolts. Tighten if necessary.

**CABLES:** Check tension, end fitting and cable coating. Replace if damage or worn. (NOTE: NEW CABLES ALWAYS STRETCH DURING USE. REFER TO STEP 15, PAGE 17 TO ADJUST CABLE TENSION)

**FRAME:** Clean with a damp cloth.

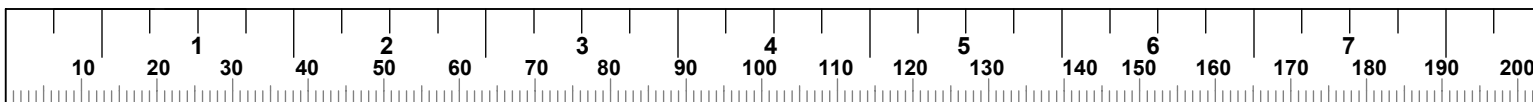
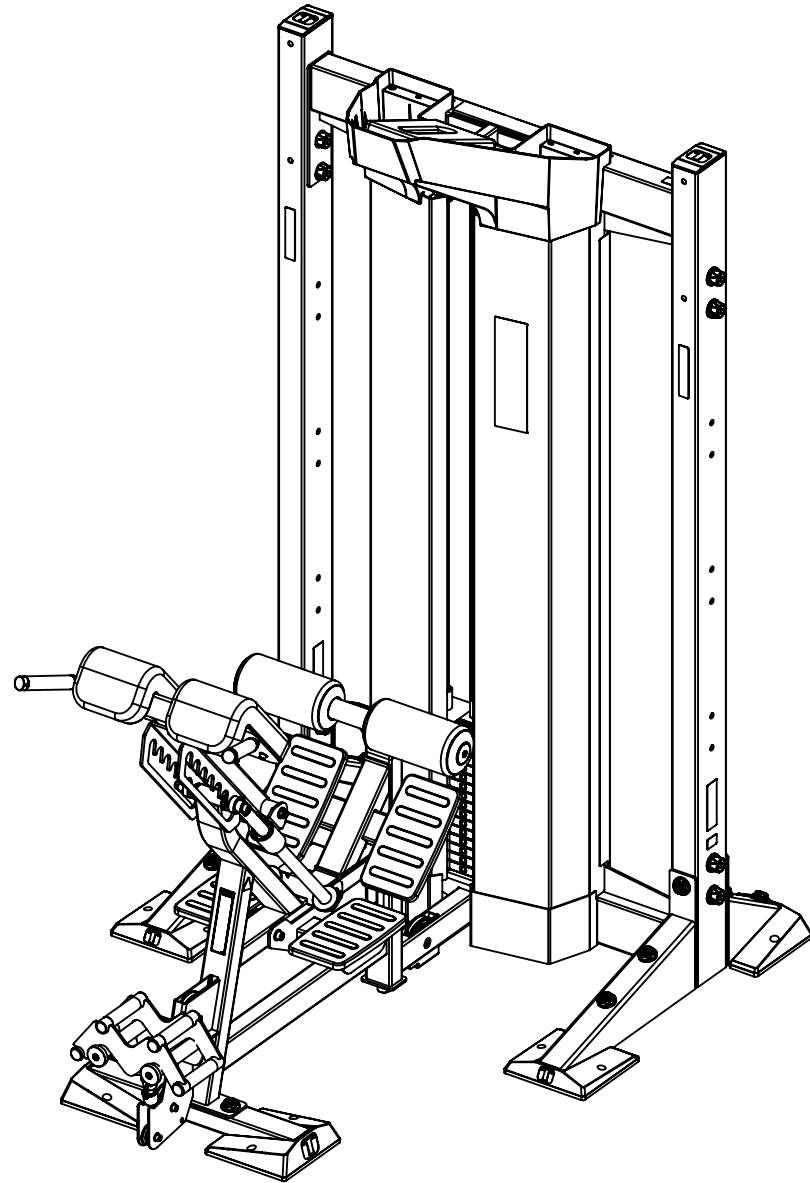

## ***DIMENSIONS***

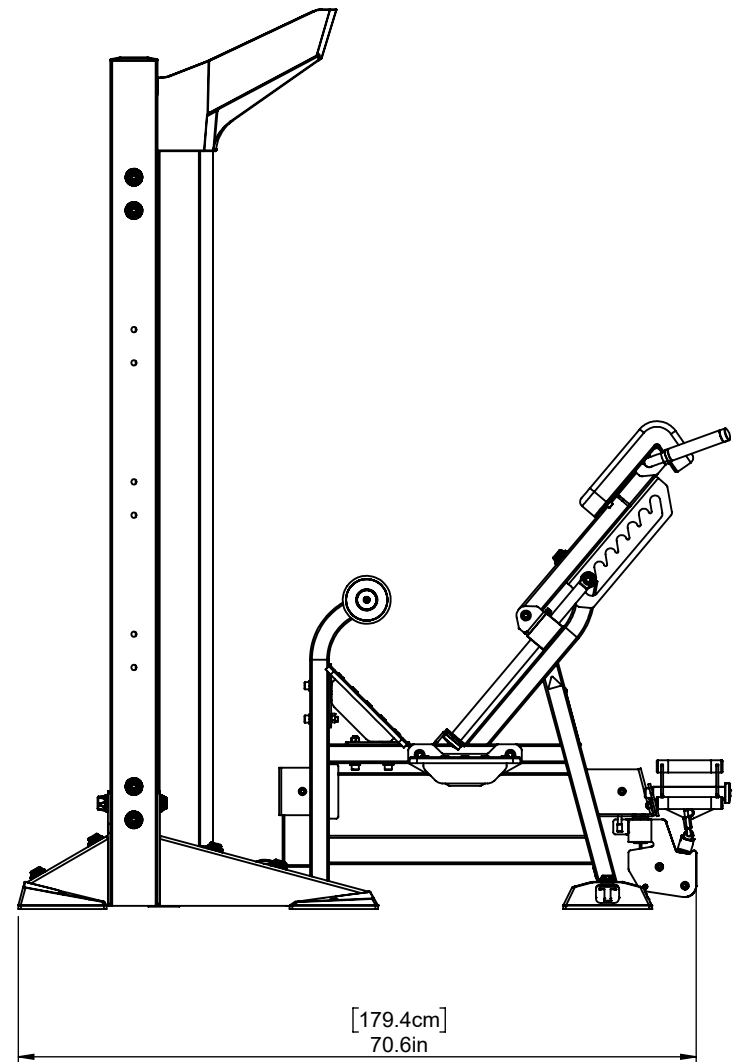
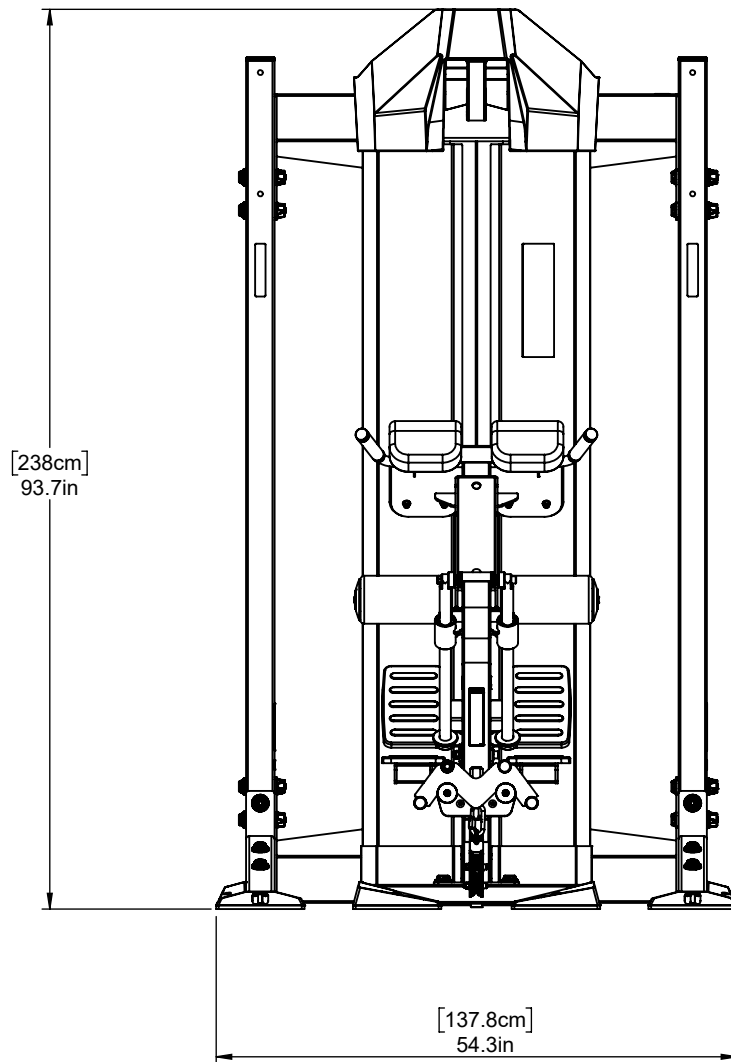

**TOTAL UNIT WEIGHT : 765 LBS [347 KG]**

**LIVE AREA**

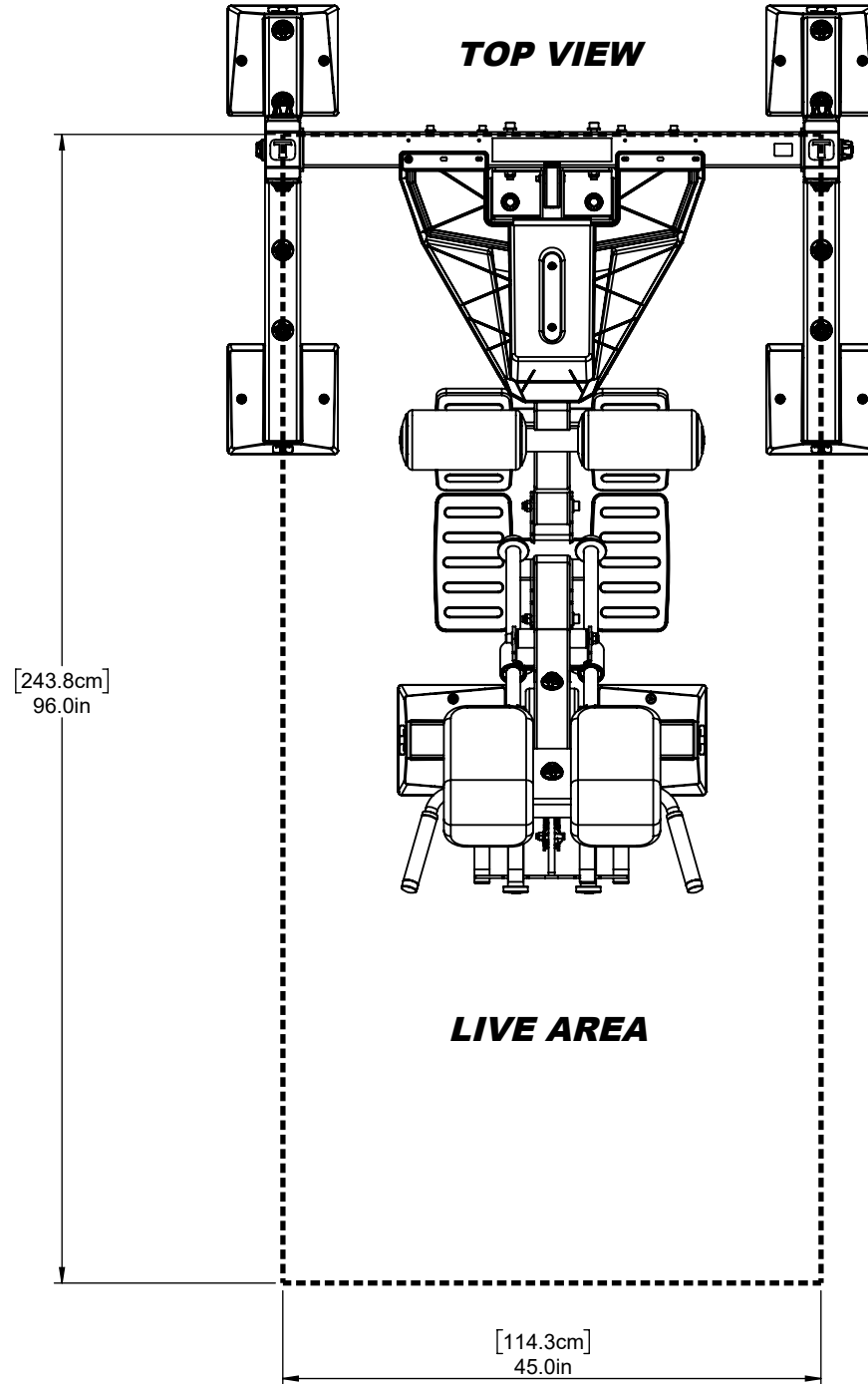

**BACK  
EXTENSION**

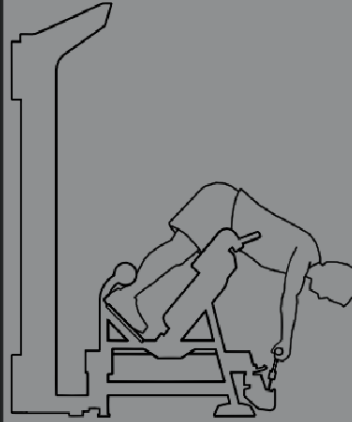

**START**

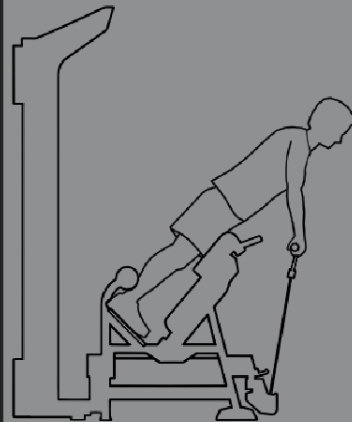

**FINISH**

**TORQUE** USA