

8 FT (2.4) TWO TIER PRO STYLE DUMBBELL RACK ASSEMBLY GUIDE

VERSION: XC82TPSDR-101

PART #: 6083201-A

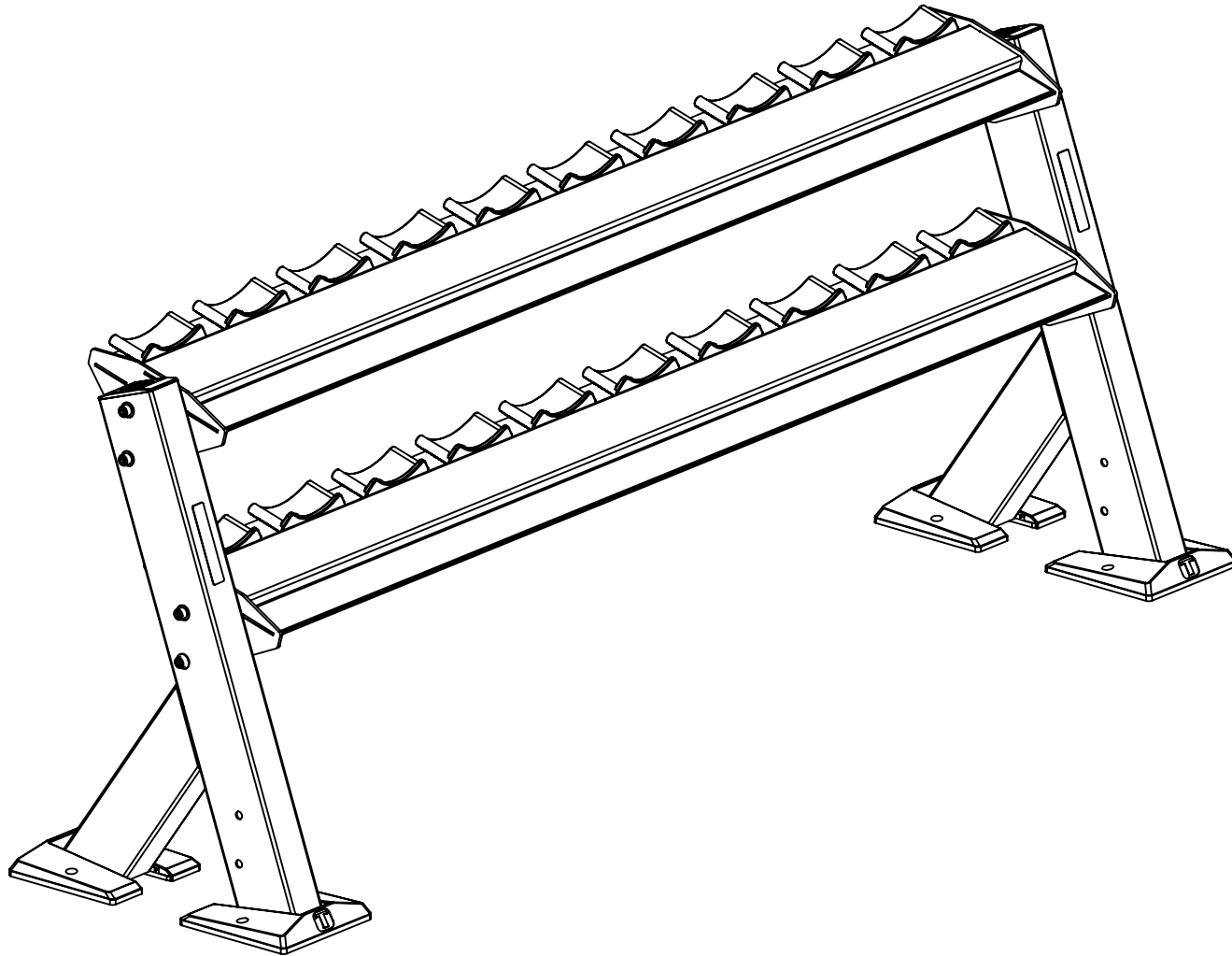

TORQUE USA

WARNING !

Important safety instructions for using Equipment

There is a risk assumed by the individuals who use this type of equipment. To minimize risk, you must follow these precautions:

1. **READ ALL INSTRUCTIONS AND WARNING LABELS COMPLETELY PRIOR TO ANY USE OR ASSEMBLY.** Failure to read and follow the safety instructions and warnings within the Assembly and Maintenance Guide may result in possible serious injury or death. Use this product only for the intended uses described in the Assembly and Maintenance Guide and exercise booklet. **DO NOT** modify equipment in anyway. Any use other than as intended or modification of product will void any and all product warranties.
2. Consult your physician before starting any exercise program. Warm up properly before engaging in resistance training. Stop exercising and consult a physician immediately if you experience dizziness, nausea, faintness, chest pain, shortness of breath or any other abnormal symptoms during use of this equipment.
3. Certain exercise equipment and/or equipment may not be suitable or appropriate for pregnant women, people with heart conditions, balance impairment or other pre-existing health problems. Persons with disabilities should consult a physician and obtain medical approval prior to using this product and should only use this product under close supervision. **Failure to comply with these instructions will void any and all product warranties.**
4. Carefully inspect equipment before each use. Replace all parts at the first sign of wear or damage. Tighten all loose connections. Pay special attention to cable ends and connections. Do not disassemble, remove any parts or components or otherwise attempt to repair this product. **DO NOT** use product if product appears damaged. **DO NOT** attempt to fix a broken or jammed machine, obtain assistance from your authorized Torque Fitness Dealer. **Failure to comply with these instructions will void any and all product warranties.**
5. Keep body and clothing clear of all moving parts. Do not put any foreign on or near this product when in use. Wear comfortable clothing which does not impair freedom of movement. Do not wear clothing which is too loose and could get caught in moving parts.
6. Make sure all adjustment spring pins are fully engaged after making an adjustment and before using the product.
7. Make sure weight stack selector pin is completely inserted into the weight stack before beginning any exercise.
8. Children and pets must not be allowed near this machine. Supervise teenagers. This product is not a toy. Owner must notify any user of all warnings and proper use of equipment.
9. This product is designed for Class S, Studio or Commercial indoor use only. Unless directly specified, the maximum user weight is 300 lbs. (136 kgs.). If unsure of proper use of this product, contact Torque Fitness Customer service at: **763-754-7533** (8:30 am - 5:00 pm CST) or email service@torquefitness.com

Important Safety Instructions for Assembling Equipment

1. **Assistance is required. Torque Fitness recommends using more than one person to assemble this equipment.**
2. This product must be assembled on a flat, level surface to assure its proper function. Locate the unit a few inches from walls or furniture to allow easy access during assembly and use.
3. Read each numbered step in Assembly and Maintenance Guide and follow the steps in sequence. Skipping ahead may result in damage to the equipment and may require components to be disassembled.
4. Wear proper attire during the assembly process. Do not wear clothing which is too loose or open toed shoes.

Obtaining Service

Do not attempt to service the product yourself except for maintenance tasks described in this manual.

Refer to the Adjustments and Maintenance section at the back of this manual and the included workout booklet for information on product operation and service.

For further information, visit our website at www.torquefitness.com or contact us at service@torquefitness.com

If you call or email customer service, have the model number and serial number(s) available. The location of the model and serial numbers are indicated in the back of this manual. For future reference, write the model and serial number(s) in the space below.

Model Number: _____

Serial Number(s): _____

Torque Fitness
11201 Xeon Street NW Suite 101
Coon Rapids, MN USA 55448

GENERAL NOTES

CAUTION: More than one person is required to assemble this unit. Do not attempt to assemble by yourself.

Unpacking the Equipment

This product may be packaged and shipped in multiple boxes. Parts from all of the boxes are required for various steps during the assembly process.

Carefully open each box and arrange all the parts near the area where assembly is to take place.

CAUTION: Use extreme care when cutting plastic tie wraps and package banding. A wire cutter works best for protecting yourself and the parts.

CAUTION: Some of the internal boxes may contain upholstery. Do not use a utility knife to open any boxes or the pads may be damaged.

The hardware is packed in bags. Carefully open each bag and sort them per parts list on the next page.

Before starting assembly, identify each part and hardware item as listed in the parts list on the next page. If any items are missing, contact Torque Fitness Customer service at: **763-754-7533** or **service@torquefitness.com**

Note: Some items listed in the parts list may be pre-installed on the product.

Tools Required

- 3/8" Ratchet
- 3/8" Allen wrench or socket
- 3/16" Allen wrench or socket
- 3/4" Wrench and or socket
- Rubber mallet
- Wire snips (to cut plastic tie wraps)
- Scissors or utility knife (to cut hardware bags)
- Step stool or ladder
- Tape measure

Optional Equipment

Optional equipment may be available for this product.

Follow the instructions included with the optional equipment to assemble it to the base product.

Assembly Tips

- In a continual effort to improve our products, specifications are subject to change.
- A 6" scale is provided at the bottom of this page. To correctly measure the bolts, measure from underneath the bolt head to the end of the bolt as illustrated below.
- Read all notes on each page before beginning that step.
- Some of the items shown in the assembly steps may be pre-assembled.

Assembly Tips Continued

- **Note:** Some items have been hidden for assembly clarity.
- **Note:** Some pre-assembled parts may need to be temporarily removed in order to complete the step. Follow the instructions or damage to the product could occur.
- Some parts may have extra holes that will not be used. Use only the holes depicted in the instructions.
- Certain parts make reference to the right and left side of the machine. In order to determine the left and right side, stand in front of the machine.
- Provide ample space around the product for ease of assembly.
- **DO NOT** fully tighten any connections until instructed to do so. This will help insure that the alignment of all of the parts will be correct.
- Insert all bolts in the direction indicated in the instructions. Failure to do so may result in clearance issues and will degrade the aesthetics of the product.
- Carefully follow instructions for all pivot points. In general, primary rotating parts have connections that should be securely tightened, while secondary connections need to be loosen 1/4 turn.

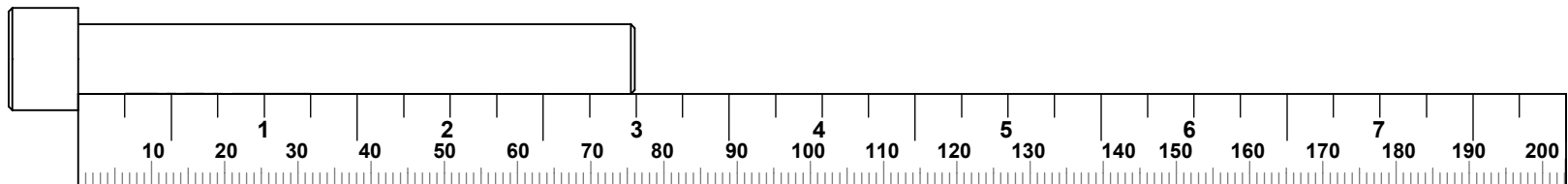

DECALS AND WARNING

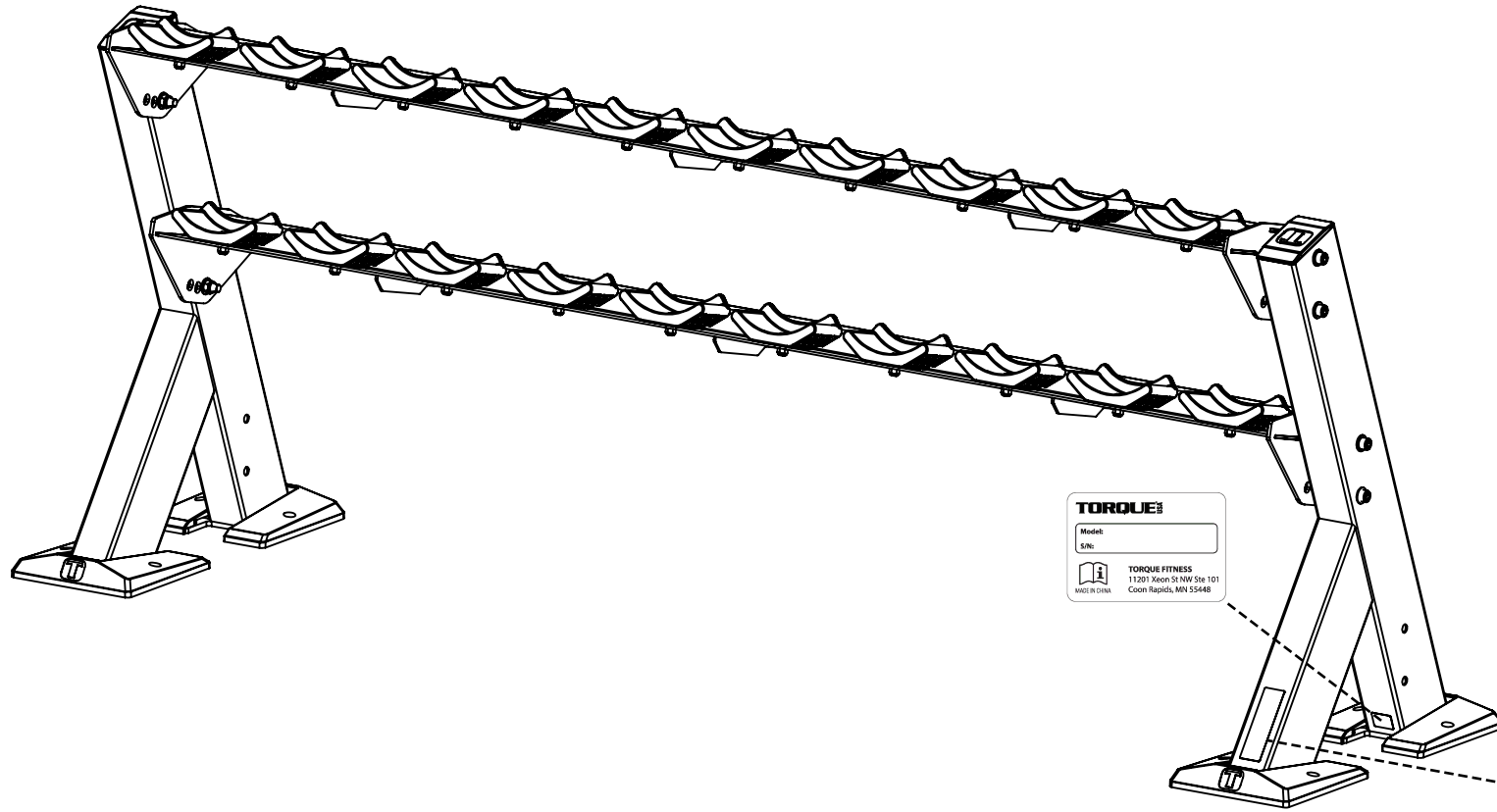

TORQUE
 Model:
 S/N:
 TORQUE FITNESS
 11201 Xeon St NW Ste 101
 Coon Rapids, MN 55448
 MADE IN CHINA

WARNING

SERIOUS INJURY CAN OCCUR ON THIS EQUIPMENT. YOU MUST FOLLOW THESE PRECAUTIONS TO AVOID INJURY:

1. Before using rowing machine, always read all safety warnings and caution statements on the use of the machine. Use only the intended accessories. DO NOT modify the machine.
2. Do not use the machine unless you are properly instructed in its operation.
3. Keep body clear and clothing free of moving objects.
4. Do not use machine for use not intended for. DO NOT attempt to fix a broken or jammed machine. Notify authorized dealer.
5. Children must not be allowed near the machine. Supervise youngsters.
6. The safety instructions and this product are secured to the front console. Be sure to reread instructions or apply over when in use.
7. DO NOT REMOVE THIS LABEL. REPLACE IF DAMAGED.

PH-5611-001

WEIGHTS AND DIMENSIONS

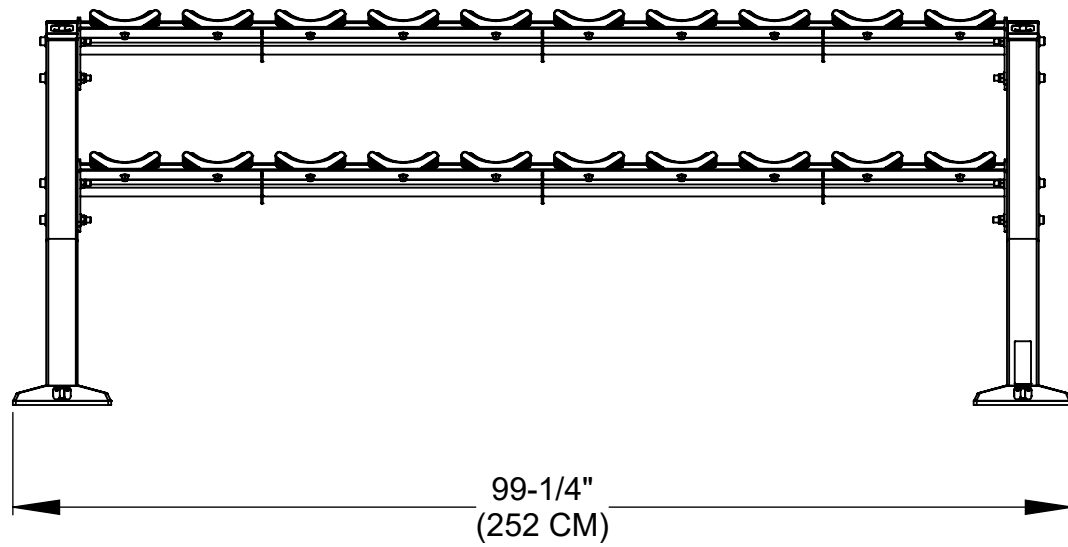
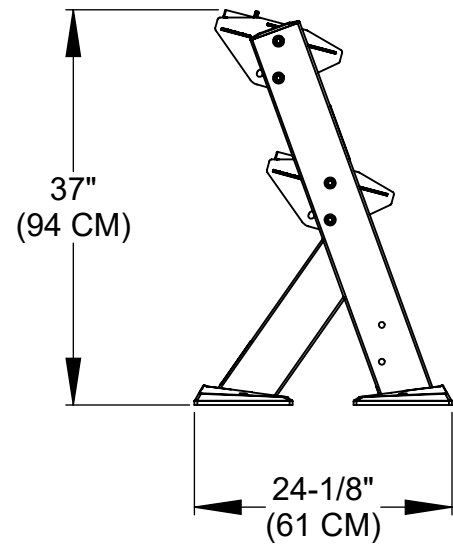

PRODUCT WEIGHT: 218 LBS (99 KG)

LIVE AREA

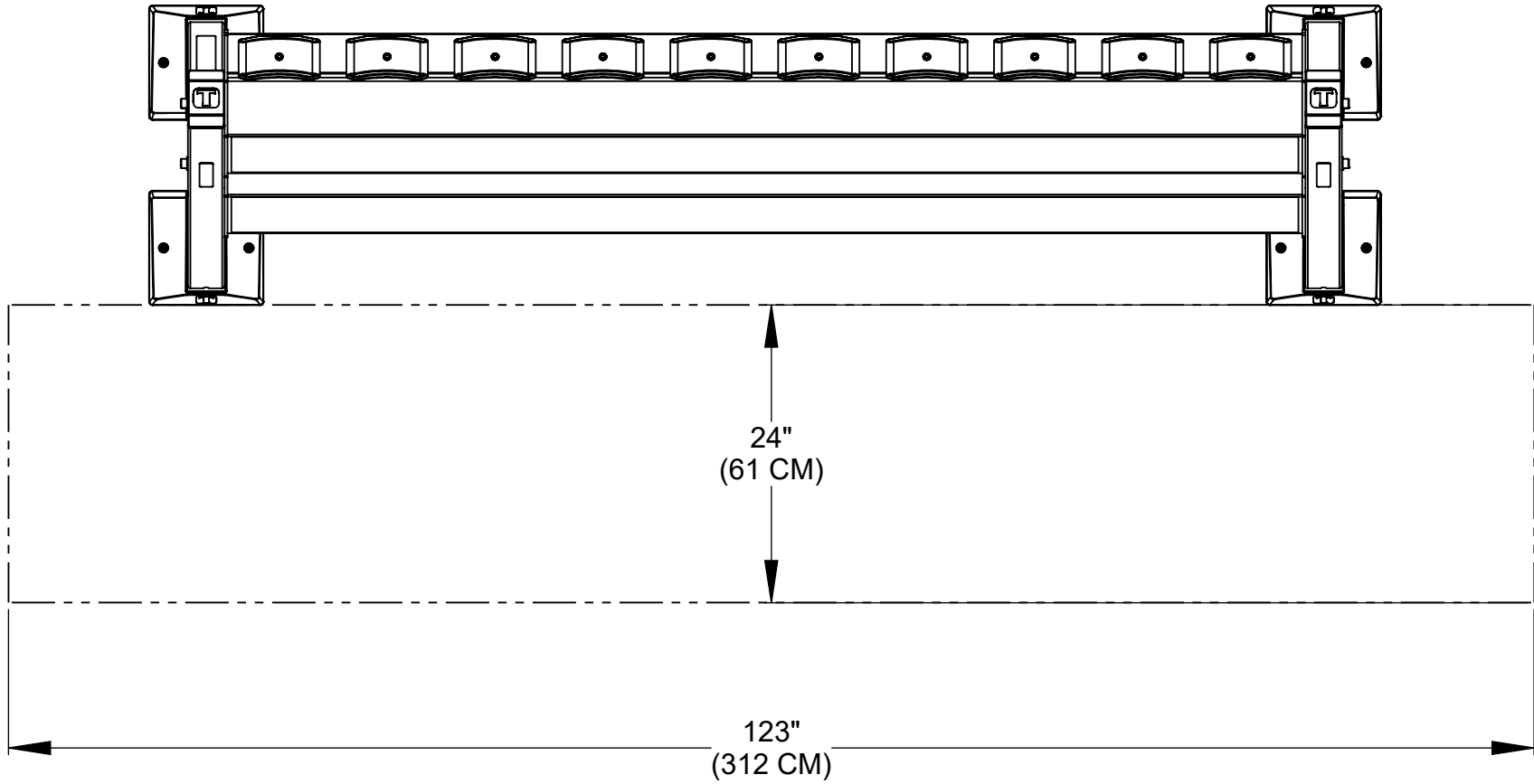

TOP VIEW

ITEM NO.	PART NUMBER	DESCRIPTION	QTY
1	57836PA	PTD ASSY, STORAGE RACK SIDE	1
2	58054PA	PTD ASSY, STORAGE RACK SIDE	1
3	60026PA	PTD ASSY, 8' SADDLE DUMBBELL RACK TIER	2
4	2001301	WASHER, FLAT 1/2 SAE ST ZN	16
5	2005816	BOLT, 1/2-13 X 4-1/4" (108mm) SOCKET HEAD	8
6	2001401	NUT, 1/2-13 LK ST ZN	8
7	6008101	COVER, FRONT BASE	4
8	2002101	WASHER, FLAT 1/4 SAE ST ZN	8
9	2005509	BOLT, 1/4-20 X 3/8" (9mm) SOCKET HEAD	8

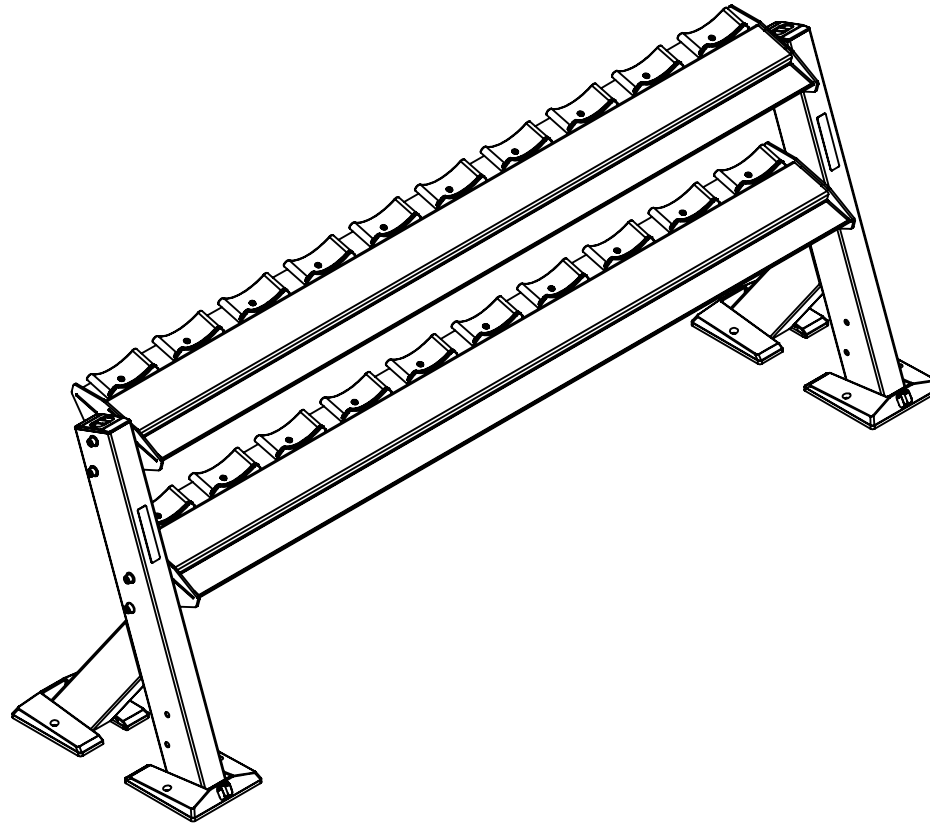

STEP 1

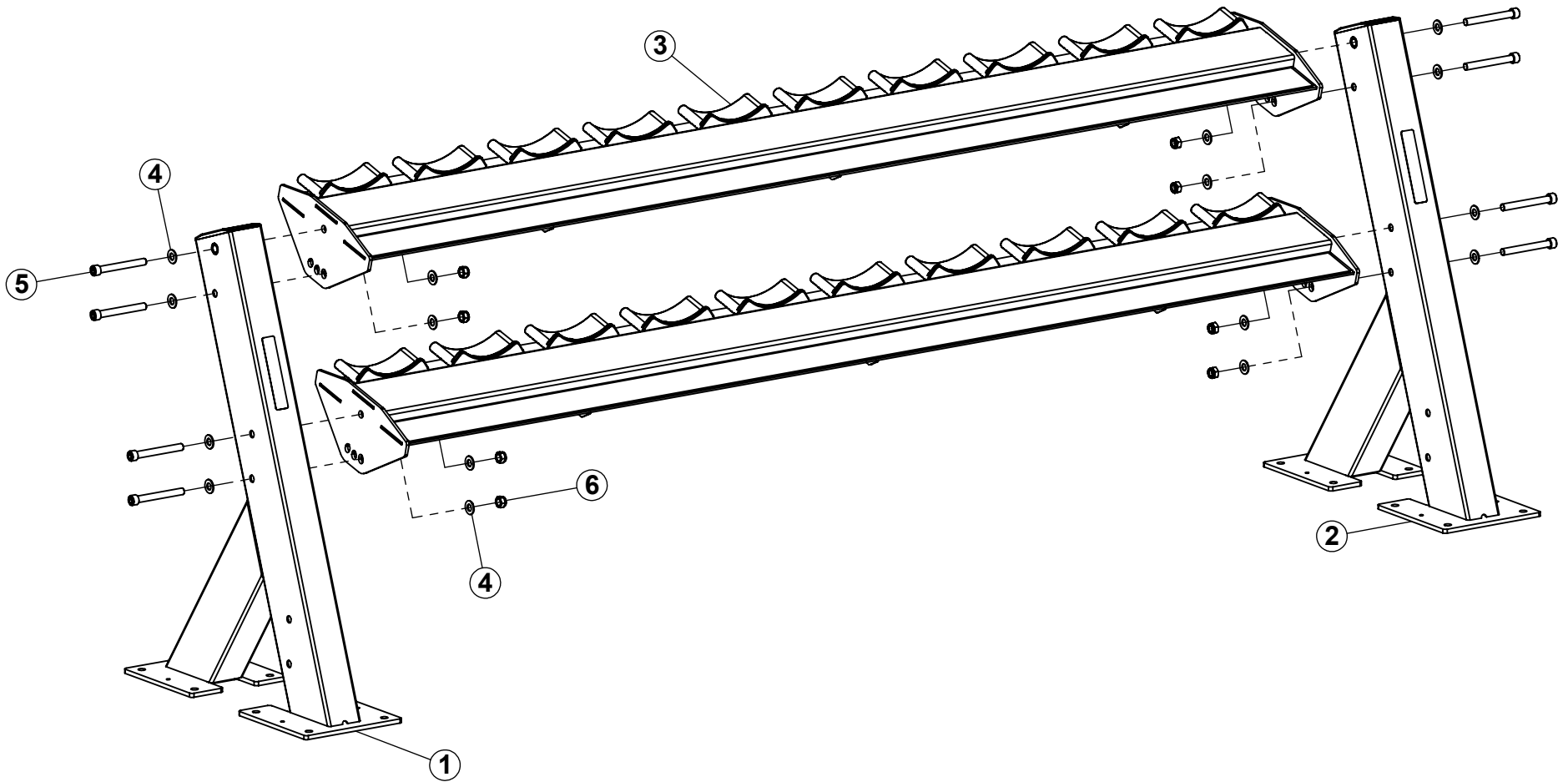

NOTES:

This step requires two people to assemble. Please get help.

Assemble all parts together first, then **SECURELY** tighten all bolt connections.

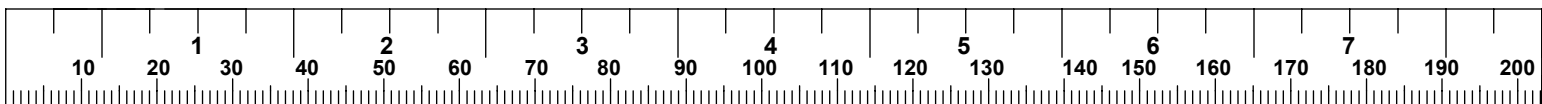

STEP 2

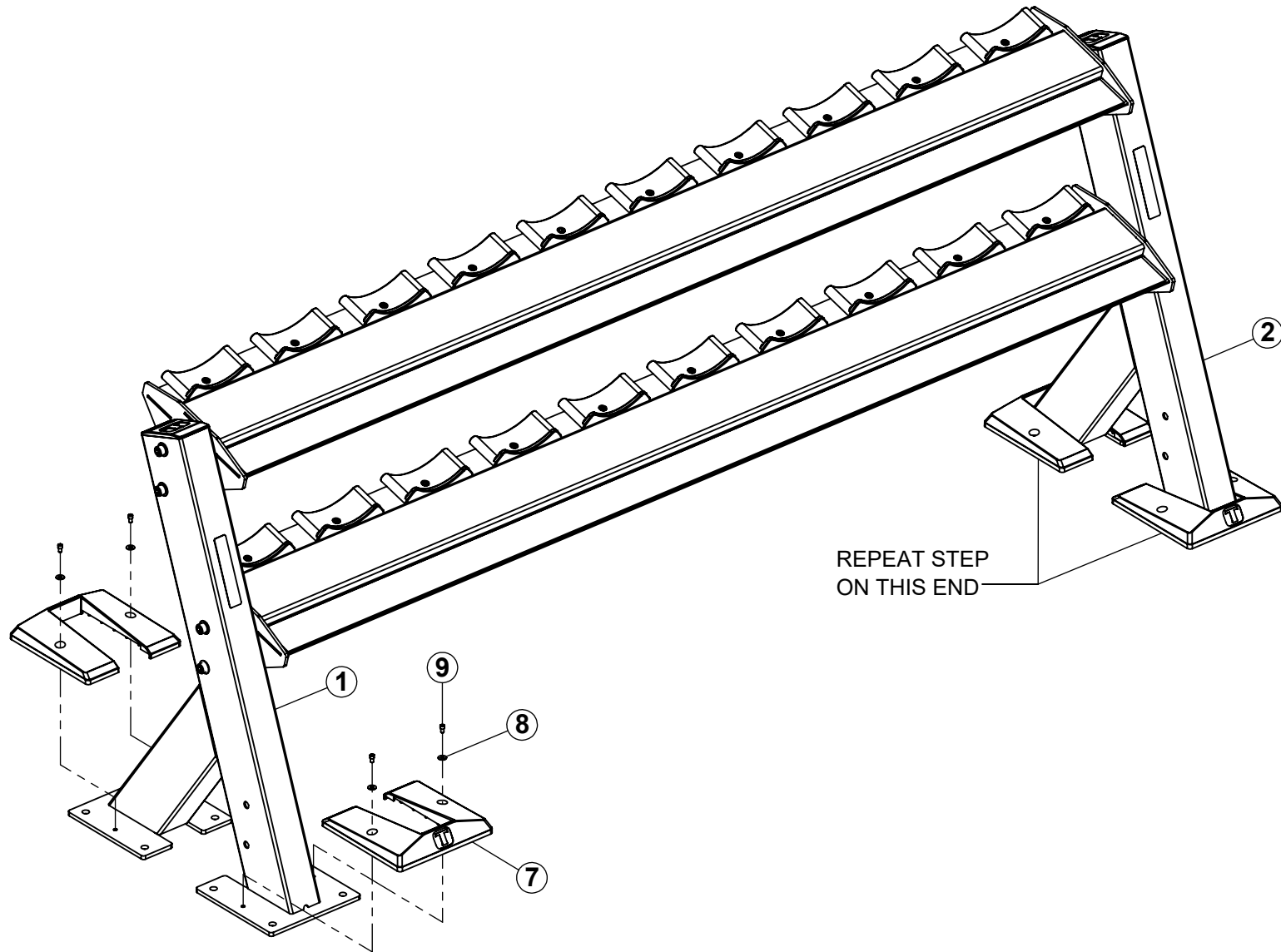

NOTE:

SECURELY tighten all bolt connections in this step.

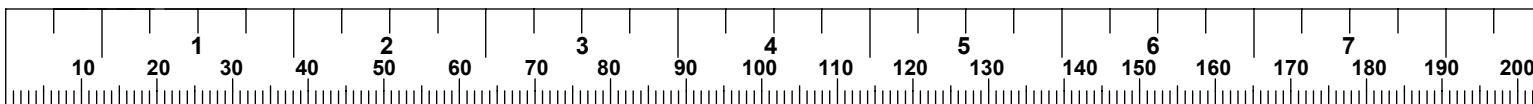

MAINTENANCE

INSPECTION: Once a month, check for loose bolts. Tighten if necessary.

FRAME: Clean with a damp cloth.

