

## ***ASSEMBLY INSTRUCTIONS***

### **4 FT (1.2 M) STANDING HIP ABDUCTOR WALL MOUNT**

# WARNING !

## Important safety instructions for using Equipment

There is a risk assumed by the individuals who use this type of equipment. To minimize risk, you must follow these precautions:

1. **READ ALL INSTRUCTIONS AND WARNING LABELS COMPLETELY PRIOR TO ANY USE OR ASSEMBLY.** Failure to read and follow the safety instructions and warnings within the Assembly and Maintenance Guide may result in possible serious injury or death. Use this product only for the intended uses described in the Assembly and Maintenance Guide and exercise booklet. **DO NOT** modify equipment in anyway. **Any use other than as intended or modification of product will void any and all product warranties.**
2. Consult your physician before starting any exercise program. Warm up properly before engaging in resistance training. Stop exercising and consult a physician immediately if you experience dizziness, nausea, faintness, chest pain, shortness of breath or any other abnormal symptoms during use of this equipment.
3. Certain exercise equipment and/or equipment may not be suitable or appropriate for pregnant women, people with heart conditions, balance impairment or other pre-existing health problems. Persons with disabilities should consult a physician and obtain medical approval prior to using this product and should only use this product under close supervision. **Failure to comply with these instructions will void any and all product warranties.**
4. Carefully inspect equipment before each use. Replace all parts at the first sign of wear or damage. Tighten all loose connections. Pay special attention to cable ends and connections. Do not disassemble, remove any parts or components or otherwise attempt to repair this product. **DO NOT** use product if product appears damaged. **DO NOT** attempt to fix a broken or jammed machine, obtain assistance from your authorized Torque Fitness Dealer. **Failure to comply with these instructions will void any and all product warranties.**
5. Keep body and clothing clear of all moving parts. Do not put any foreign on or near this product when in use. Wear comfortable clothing which does not impair freedom of movement. Do not wear clothing which is too loose and could get caught in moving parts.
6. Make sure all adjustment spring pins are fully engaged after making an adjustment and before using the product.
7. Make sure weight stack selector pin is completely inserted into the weight stack before beginning any exercise.
8. Children and pets must not be allowed near this machine. Supervise teenagers. This product is not a toy. Owner must notify any user of all warnings and proper use of equipment.
9. This product is designed for Class S, Studio or Commercial indoor use only. Unless directly specified, the maximum user weight is 300 lb (136 kg). If unsure of proper use of this product, contact Torque Fitness Customer service at: **763-754-7533** (8:30 am - 5:00 pm CST) or email **service@torquefitness.com**

## Important Safety Instructions for Assembling Equipment

1. **Assistance is required. Torque Fitness recommends using more than one person to assemble this equipment.**
2. This product must be assembled on a flat, level surface to assure its proper function. Locate the unit a few inches from walls or furniture to allow easy access during assembly and use.
3. Read each numbered step in Assembly and Maintenance Guide and follow the steps in sequence. Skipping ahead may result in damage to the equipment and may require components to be disassembled.
4. Wear proper attire during the assembly process. Do not wear clothing which is too loose or open toed shoes.

## Obtaining Service

Do not attempt to service the product yourself except for maintenance tasks described in this manual.

Refer to the Adjustments and Maintenance section at the back of this manual and the included workout booklet for information on product operation and service.

For further information, visit our website at [www.torquefitness.com](http://www.torquefitness.com) or contact us at [service@torquefitness.com](mailto:service@torquefitness.com)

If you call or email customer service, have the model number and serial number(s) available. The location of the model and serial numbers are indicated in the back of this manual. For future reference, write the model and serial number(s) in the space below.

Model Number: \_\_\_\_\_

Serial Number(s): \_\_\_\_\_

**Torque Fitness**  
**11201 Xeon Street NW Suite 101**  
**Coon Rapids, MN USA 55448**

# GENERAL NOTES

**CAUTION:** More than one person is required to assemble this unit. Do not attempt to assemble by yourself.

## Unpacking the Equipment

This product may be packaged and shipped in multiple boxes. Parts from all of the boxes are required for various steps during the assembly process.

Carefully open each box and arrange all the parts near the area where assembly is to take place.

**CAUTION:** Use extreme care when cutting plastic tie wraps and package banding. A wire cutter works best for protecting yourself and the parts.

**CAUTION:** Some of the internal boxes may contain upholstery. Do not use a utility knife to open any boxes or the pads may be damaged.

The hardware is packed in bags. Carefully open each bag and sort them per parts list on the next page.

Before starting assembly, identify each part and hardware item as listed in the parts list on the next page. If any items are missing, contact Torque Fitness Customer service at: **763-754-7533** or **service@torquefitness.com**

**Note:** Some items listed in the parts list may be pre-installed on the product.

## Tools Required

- 3/8" Allen wrench
- 5/16" Allen wrench
- 3/16" Allen wrench
- 3/4" Wrench and or socket
- 9/16" Wrench and or socket
- 1/2" Wrench and or socket
- Rubber mallet
- Wire snips (to cut plastic tie wraps)
- Scissors or utility knife (to cut hardware bags)
- Step stool or ladder
- Tape measure

## Optional Equipment

Optional equipment may be available for this product.

Follow the instructions included with the optional equipment to assemble it to the base product.

## Assembly Tips

- In a continual effort to improve our products, specifications are subject to change.
- A 6" scale is provided at the bottom of this page. To correctly measure the bolts, measure from underneath the bolt head to the end of the bolt as illustrated below.
- Read all notes on each page before beginning that step.
- Some of the items shown in the assembly steps may be pre-assembled.

## Assembly Tips Continued

- **Note:** Some items have been hidden for assembly clarity.
- **Note:** Some pre-assembled parts may need to be temporarily removed in order to complete the step. Follow the instructions or damage to the product could occur.
- Some parts may have extra holes that will not be used. Use only the holes depicted in the instructions.
- Certain parts make reference to the right and left side of the machine. In order to determine the left and right side, stand in front of the machine.
- Provide ample space around the product for ease of assembly.
- **DO NOT** fully tighten any connections until instructed to do so. This will help insure that the alignment of all of the parts will be correct.
- Insert all bolts in the direction indicated in the instructions. Failure to do so may result in clearance issues and will degrade the aesthetics of the product.
- Carefully follow instructions for all pivot points. In general, primary rotating parts have connections that should be securely tightened, while secondary connections need to be loosen 1/4 turn.

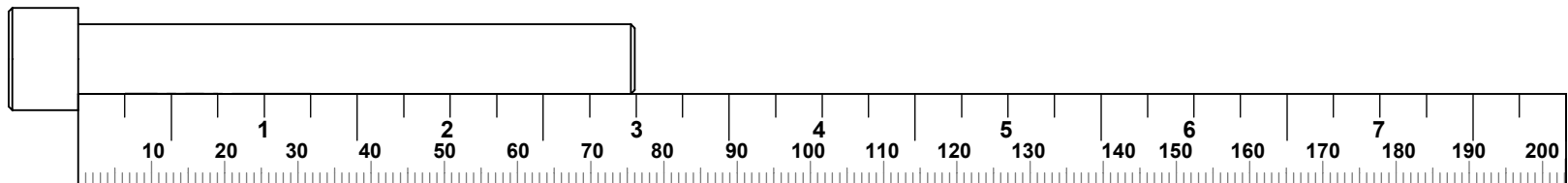

## WARNING

SERIOUS INJURY CAN OCCUR ON THIS EQUIPMENT. YOU MUST FOLLOW THESE PRECAUTIONS TO AVOID INJURY!

1. Before using, read all warnings and obtain instruction on the use of this machine. Use only for intended exercise. **DO NOT** modify the machine.
2. Obtain a medical exam before beginning any exercise program.
3. Keep body, hair and clothing free of all moving objects.
4. Inspect the machines before use. **DO NOT** use if it appears damaged. **DO NOT** attempt to fix a broken or jammed machine. Notify staff immediately.
5. Be certain that weight pin is completely inserted. Use only the pin provided by the manufacturer. If unsure, seek assistance.
6. Never pin the weights or prop plate into an elevated position. **DO NOT** use the machine if found in this condition. **DO NOT** attempt to fix. Seek assistance.
7. Inspect cables and their connections before using machine. **DO NOT** attempt to fix. Seek assistance.
8. Use only the incremental weights supplied by the manufacture. **DO NOT** use dumbbells or other means to add resistance to the machine.
9. Children must not be allowed near this machine. Supervise teenagers.
10. **DO NOT REMOVE THIS LABEL. REPLACE IF DAMAGED.**

P/N 5342301

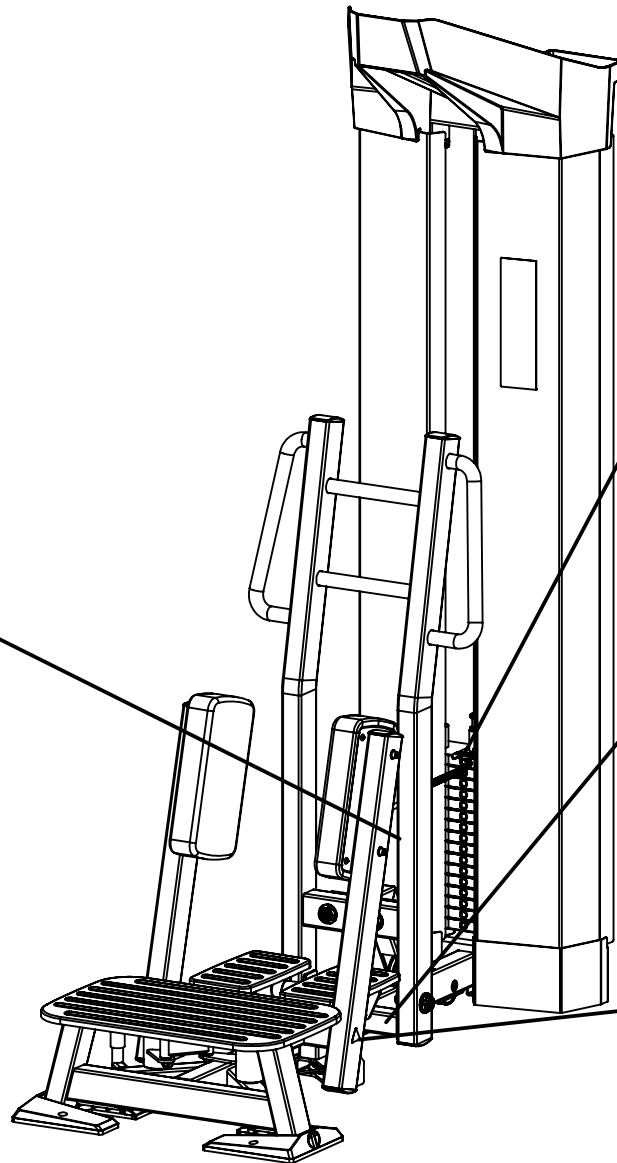

## WARNING

**WEIGHT STACK SELECTOR  
MUST BE FULLY ENGAGED**

# TORQUE<sup>USA</sup>

Model:

S/N:



MADE IN CHINA

**TORQUE FITNESS**

11201 Xeon St NW Ste 101  
Coon Rapids, MN 55448



**EXERCISE INSTRUCTIONS**

**HIP  
ABDUCTION**

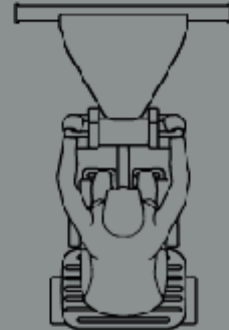
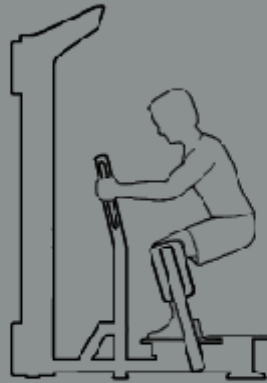

**START**

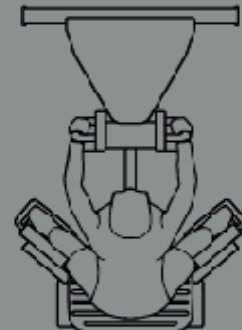

**FINISH**

**TORQUE** USA

ITEM NO.	PART NUMBER	DESCRIPTION	QTY	ITEM NO.	PART NUMBER	DESCRIPTION	QTY
1	59135PA	PTD ASSY, LOWER WALL MOUNT	1	40	60197PA	PTD ASSY, LARGE FOOT PLATE	1
2	5914601	WLDMT, UPPER WALL MOUNT	1	41	5581301	COVER, FRONT BASE	2
3	2001301	WASHER, FLAT 1/2 SAE ST ZN	4	42	2006509	BOLT, 1/4-20 X 3/8" (9mm) SOCKET HEAD W/NP	4
4	2006803	SHCS, 1/2-13 X 1, CZ PATCH	4	43	56349PA	PTD ASSY, 10 LB WEIGHT PLATE	10
5	2001101	WASHER, FLAT 3/8 SAE ST ZN	12	44	2002209	BOLT, 1/2 DIA X 2-3/4" SHOULDER	2
6	2009402	BOLT, 3/8-16 X 3/4" (19mm) ST HT SOCKET HEAD W/NP	6	45	2001501	WASHER, FLAT 5/16 SAE ST ZN	4
7	60184PA	PTD ASSY, ABDUCTOR BASE	1	46	2001601	NUT, 5/16-18 LK ST ZN	4
8	2009418	BOLT, 3/8-16 X 4-3/4" (121mm) ST HT SOCKET HEAD W/NP	2	47	56350PA	PTD ASSY, 15 LB WEIGHT PLATE	5
9	5662501	WLDMT, LEFT SHROUD BASE	1				
10	5662901	WLDMT, RIGHT SHROUD BASE	1				
11	56345PA	PTD ASSY, HEAD PLATE	1				
12	5643201	GUIDE ROD, 19 DIA X 1912	2				
13	5996401	BUSHING, GUIDE ROD RETAINER	2				
14	5513601	CUSHION, WEIGHT STACK	2				
15	5992401	SHAFT COLLAR, TWO-PIECE CLAMPING	2				
16	55181PA	PTD ASSY, WEIGHT SELECTOR STORAGE PLATE	1				
17	6065001	LABEL, WEIGHT STACK 15 - 190 LB (6.8 - 86.2 KG)	1				
18	2001201	NUT, 3/8-16 LK ST ZN	3				
19	2008407	BOLT, 3/8-16 X 2" (51mm) ST HT SOCKET HEAD	1				
20	5094501	PULLEY, 4-1/2 OD X 25	1				
21	59148PA	PTD ASSY, SEATED ROW TOP BOOM	1				
22	6018801	ASSY, ABDUCTOR CABLE	1				
23	5645101	SHROUD, XCREATE CABLE STATION	2				
24	5664701	SHROUD, TOP CAP	1				
25	2002101	WASHER, FLAT 1/4 SAE ST ZN	10				
26	2006502	BOLT, 1/4-20 X 1/2" (13mm) SOCKET HEAD W/NP	6				
27	6019301	PLACARD, XCREATE-SHA-101	1				
28	60098PA	PTD ASSY, HIP ABDUCTOR RIGHT LEG	1				
29	6009901	PAD, ABDUCTOR LEG	2				
30	2009411	BOLT, 3/8-16 X 3" (76mm) ST HT SOCKET HEAD W/NP	4				
31	60093PA	PTD ASSY, HIP ABDUCTOR LEFT LEG	1				
32	60110PA	PTD ASSY, ABDUCTOR CENTER SWIVEL	1				
33	60190PA	PTD ASSY, ABDUCTOR HANDLE MOUNT	1				
34	2005811	BOLT, 1/2-13 X 3" (76mm) SOCKET HEAD	4				
35	2001401	NUT, 1/2-13 LK ST ZN	4				
36	5631801	WASHER COVER, NYLON BOLT	4				
37	5631901	WASHER COVER, NYLON NUT	4				
38	6019601	PLATE, ABDUCTOR LARGE FOOT PLATE - SUPPORT	1				
39	2008503	BOLT, 3/8-16 X 1" (25mm) FLAT HEAD W/NP	4				

**NOTE:**

Anchoring hardware is dictated by the wall construction that the station is being attached to. See pages 4 and 12 for the requirements.

If multiple stations are going to be attached to the same wall, a minimum of 4' (2.4 M) center to center is recommended between stations.

For assistance, contact [sales@torquefitness.com](mailto:sales@torquefitness.com) or call (763) 754-7533; Toll free in USA (877) 867-7854.

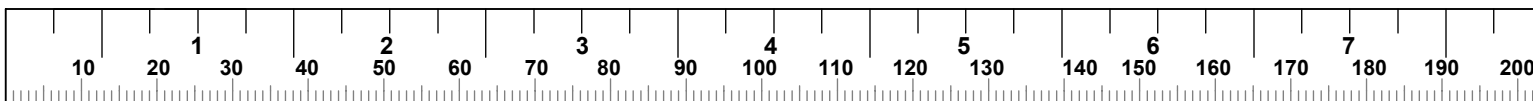

## STEP 1a

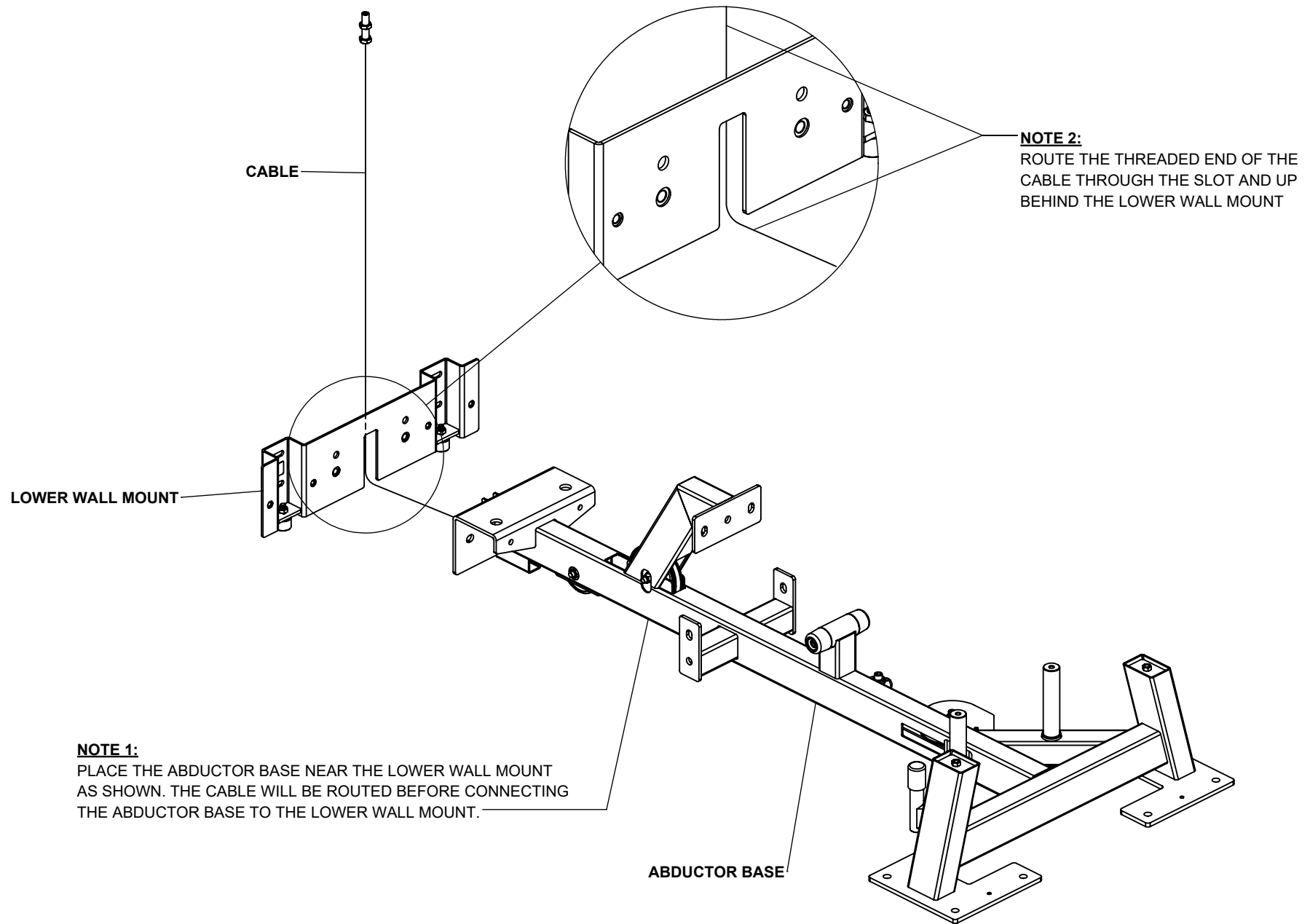

# STEP 1b

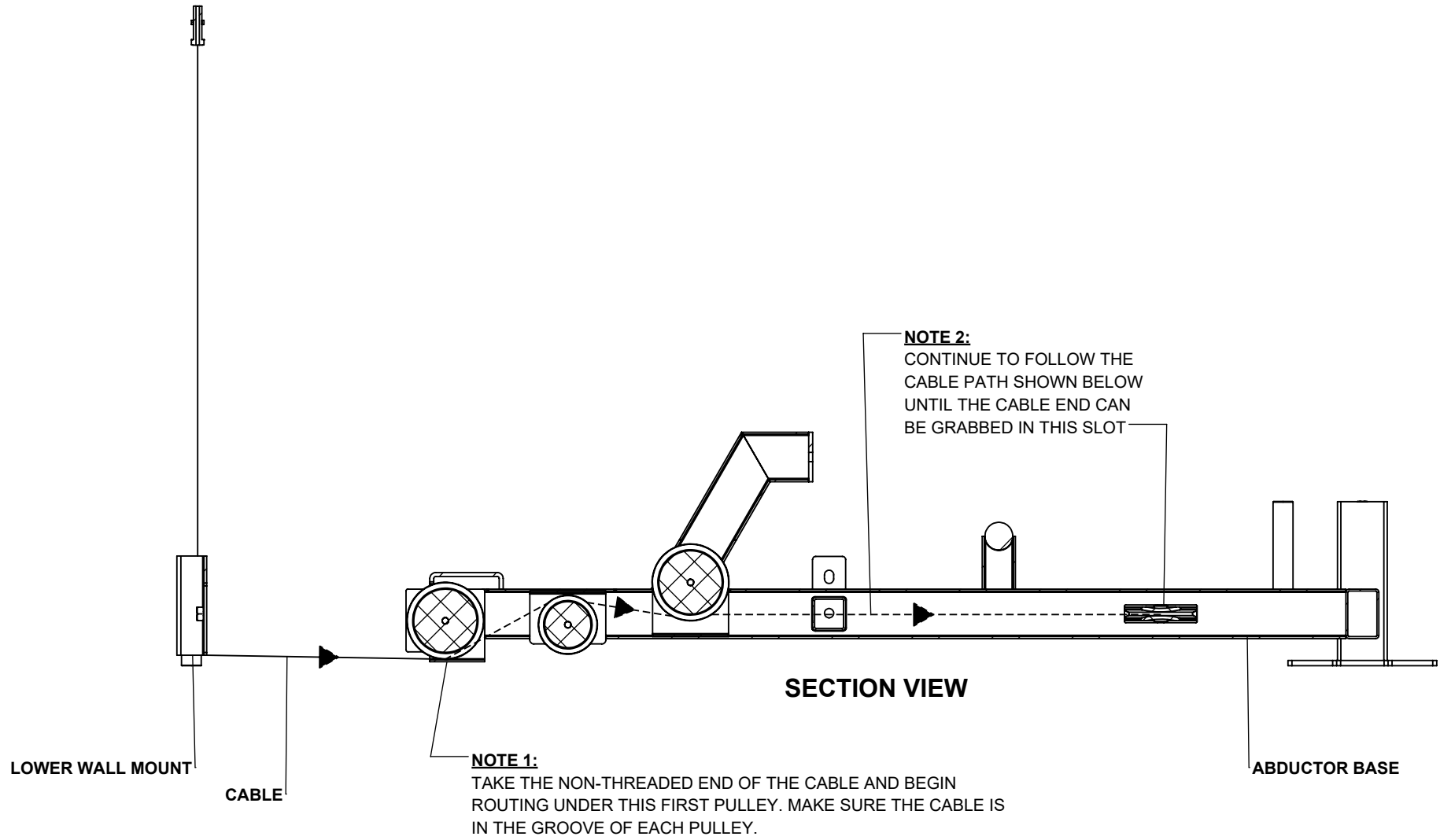

**STEP 1c**

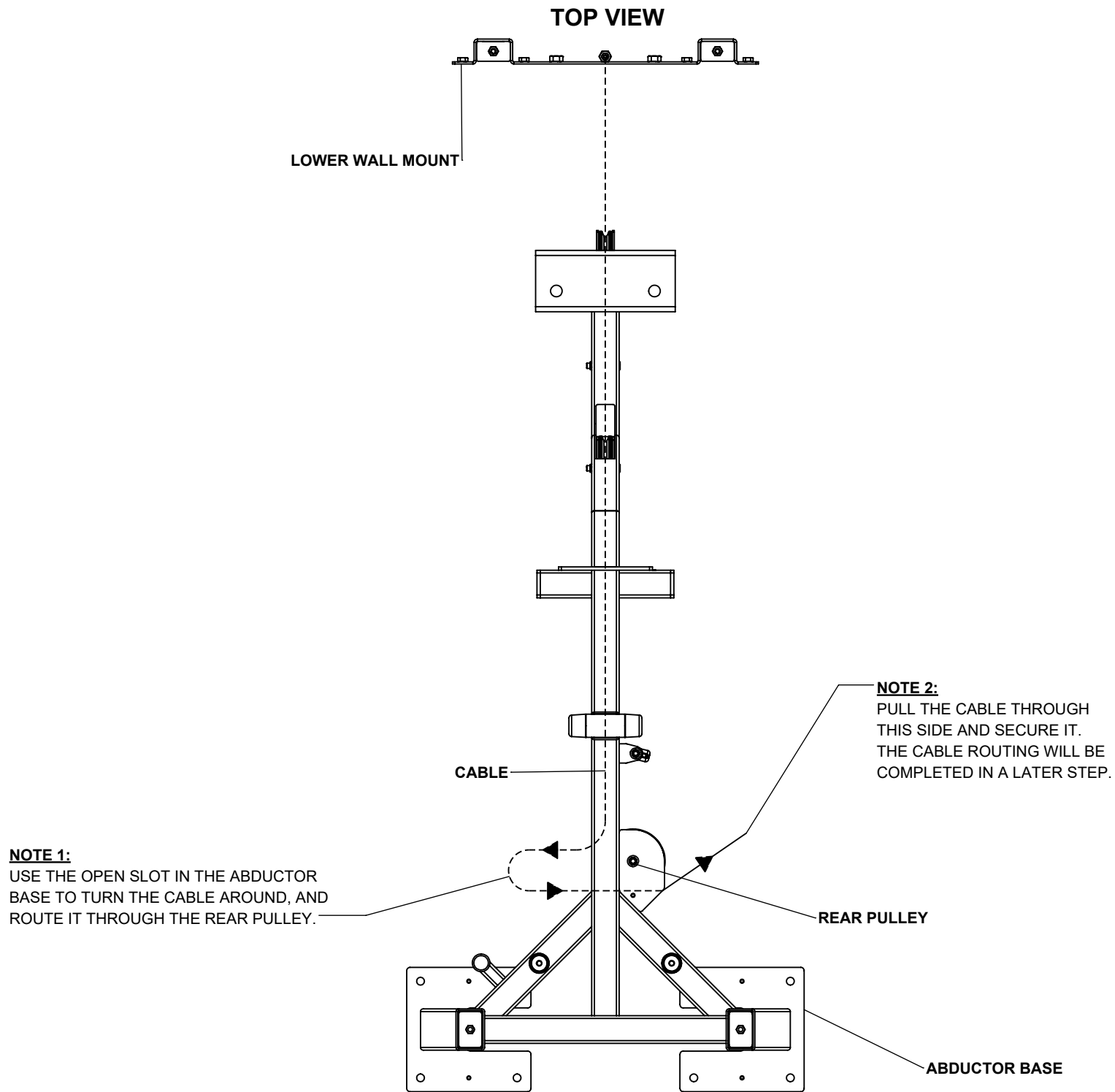

**STEP 1d**

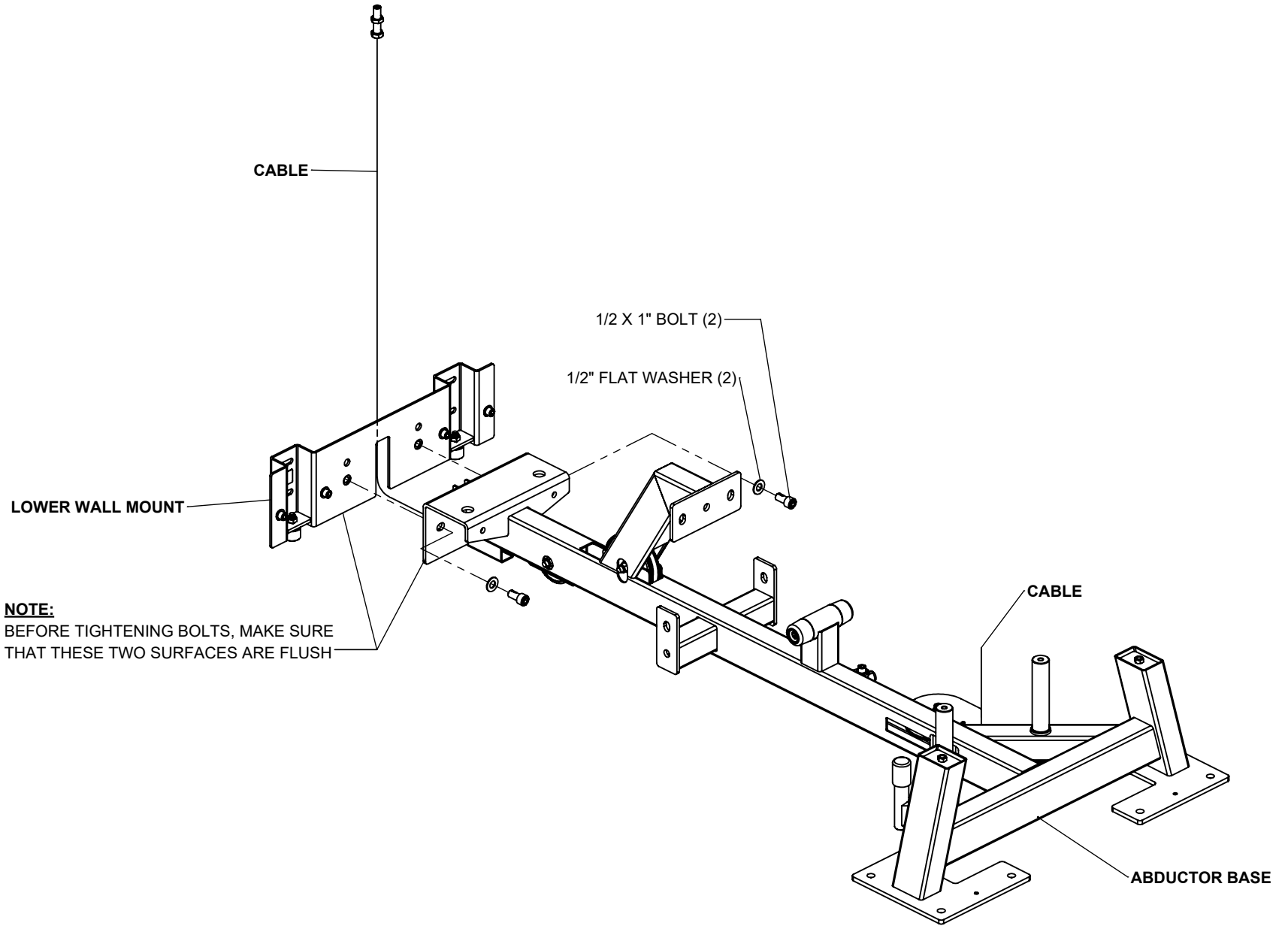

**NOTES:**

**SECURELY** tighten bolt connections in this step.

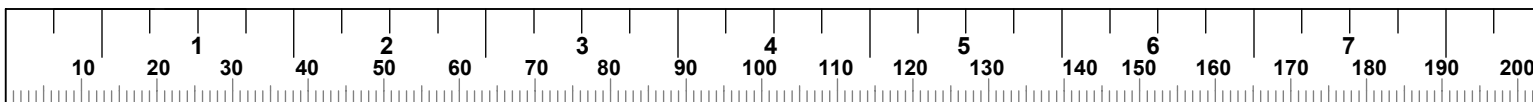

## STEP 2

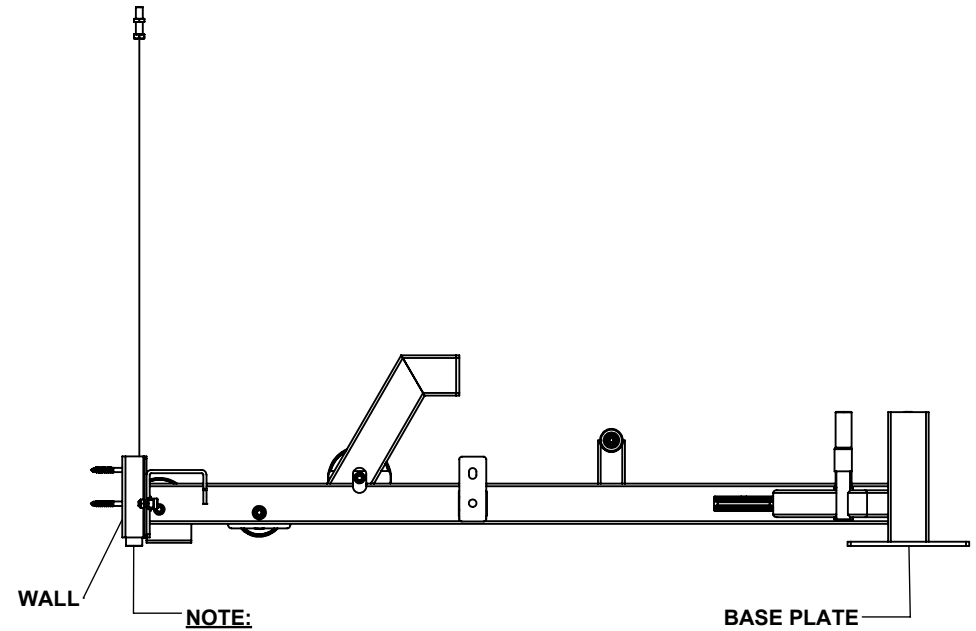
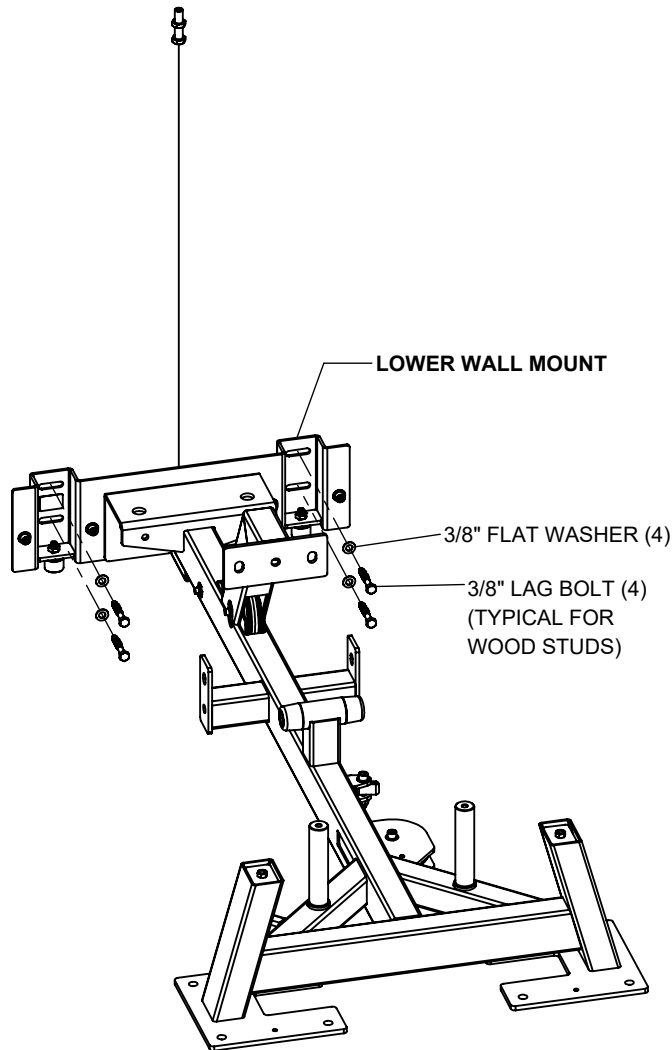

**NOTE:**  
BEFORE ANCHORING LOWER WALL MOUNT TO THE WALL, ADJUST LEVELERS (2) SO THAT THE BASE PLATE IS LEVEL WITH THE FLOOR.

**NOTE:**  
MAKE SURE THE LOWER WALL MOUNT IS LEVEL

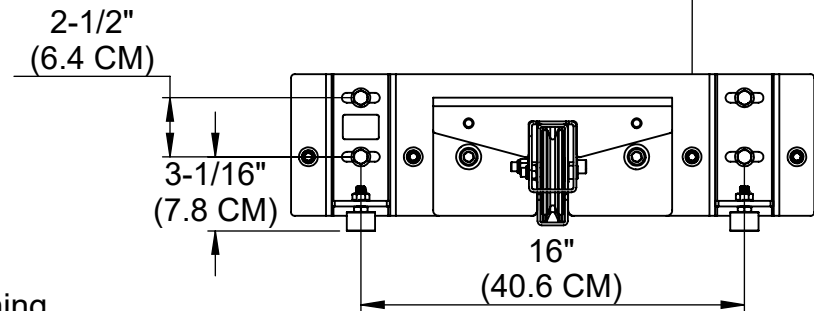

**WARNING:**  
THE LOWER WALL MOUNT **MUST** BE ANCHORED TO THE WALL USING FOUR WALL ANCHORS SUITABLE FOR THAT PARTICULAR WALL CONSTRUCTION.

### NOTES:

The images shown above is the anchoring hardware used for attaching to typical walls with wood studs spaced 16" on center. The anchors used will depend on the wall construction. In all cases, all four anchoring locations must be used. The pull-out strength of the anchoring bolts used must be greater than or equal to 200lbs. (91kg)

**SECURELY** tighten bolt connections in this step.

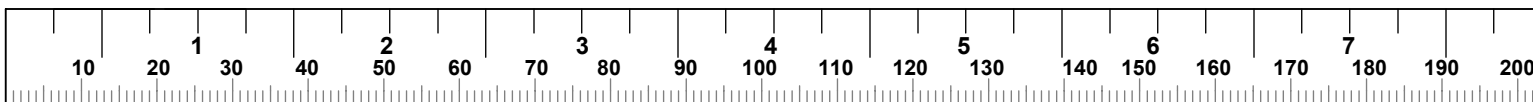

**STEP 3**

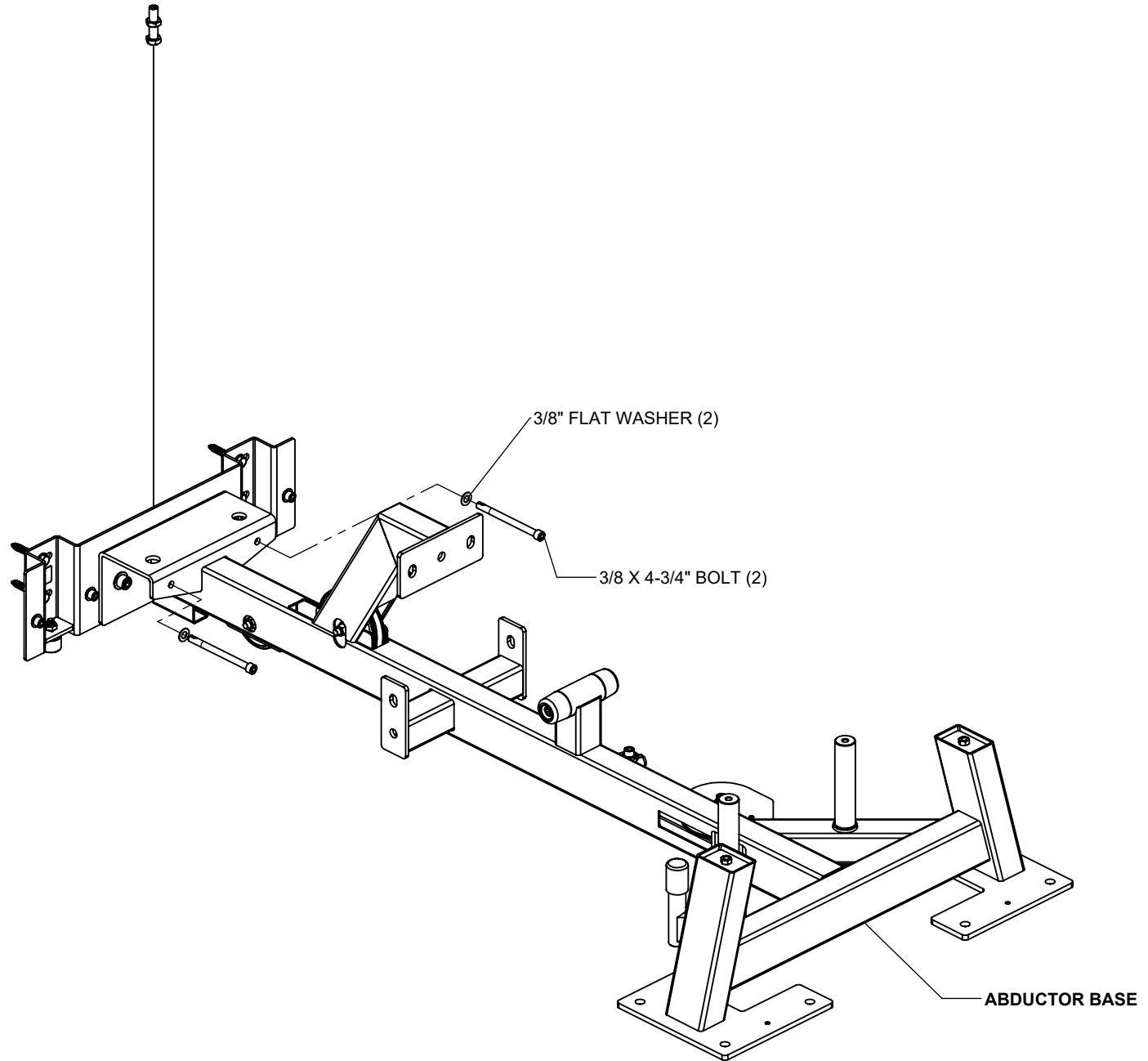

**NOTES:**

**SECURELY** tighten bolt connections in this step.

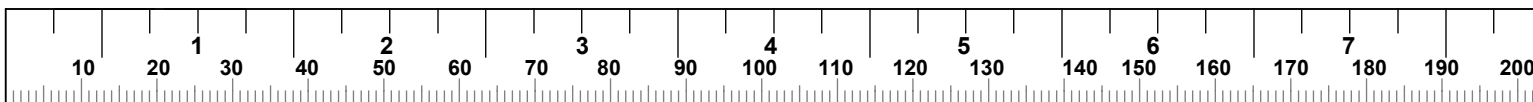

**STEP 4**

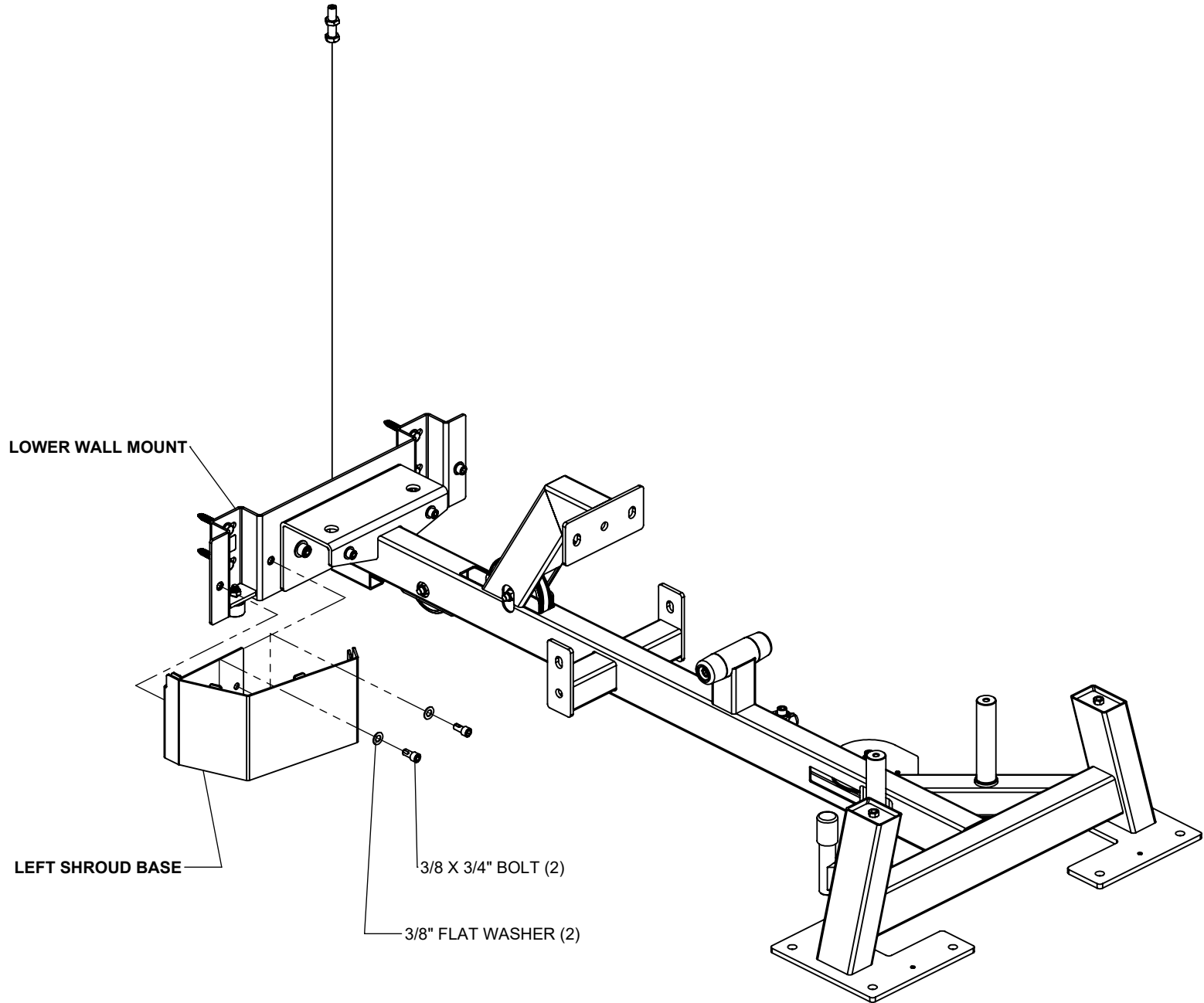

**NOTES:**

**SECURELY** tighten bolt connections in this step.

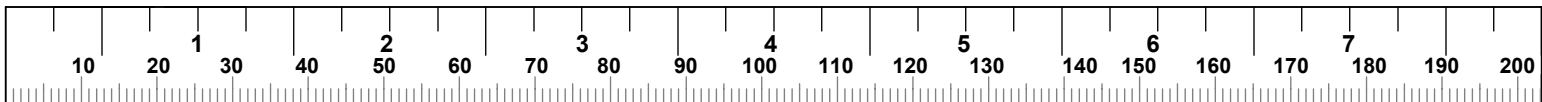

**STEP 5**

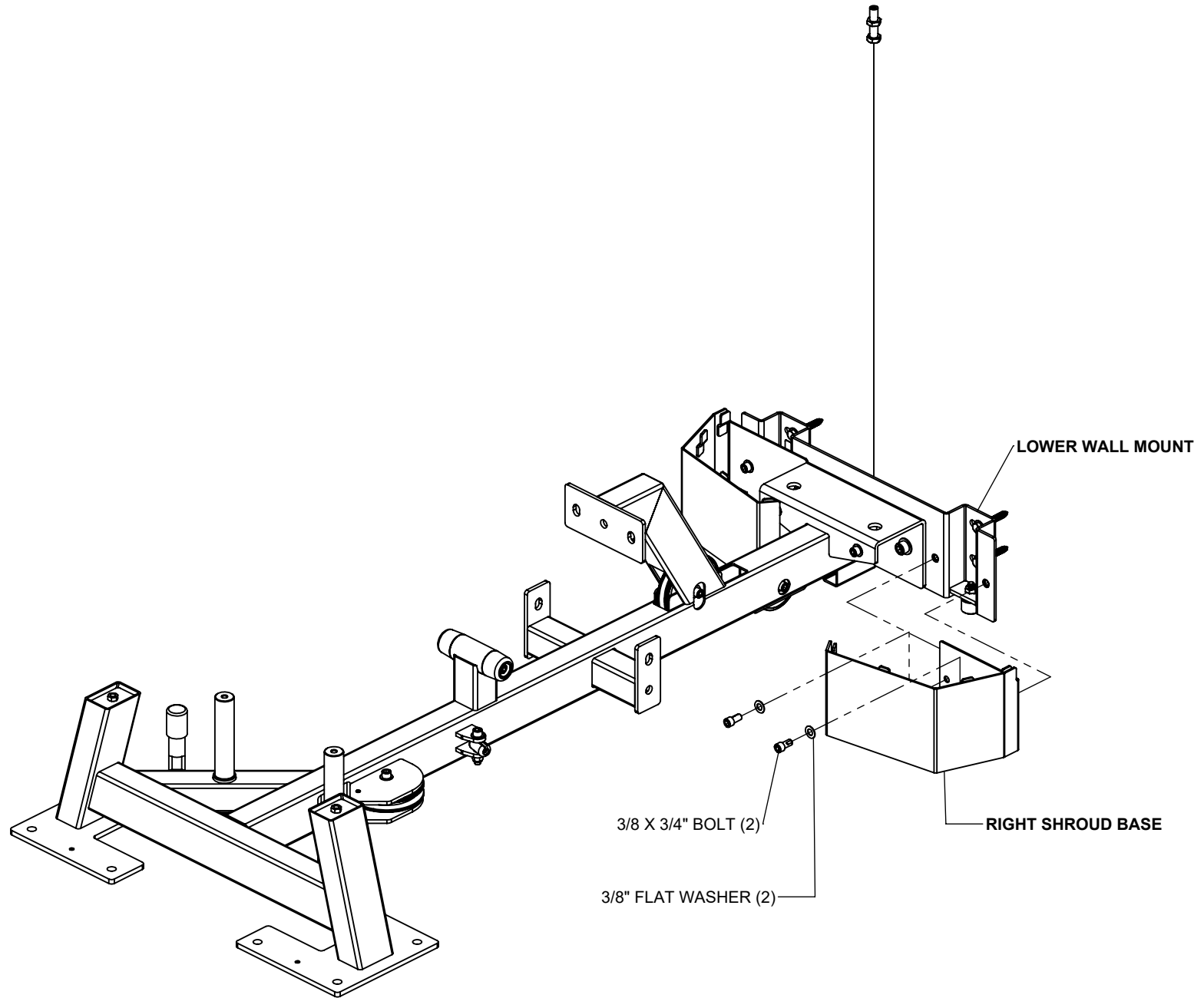

**NOTES:**

**SECURELY** tighten bolt connections in this step.

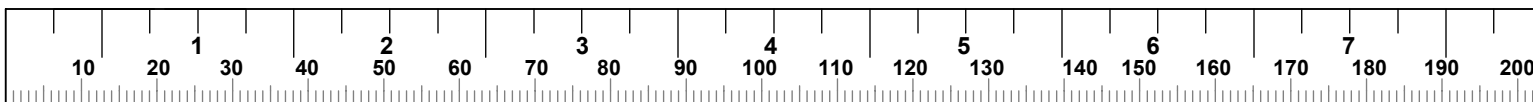

# STEP 6

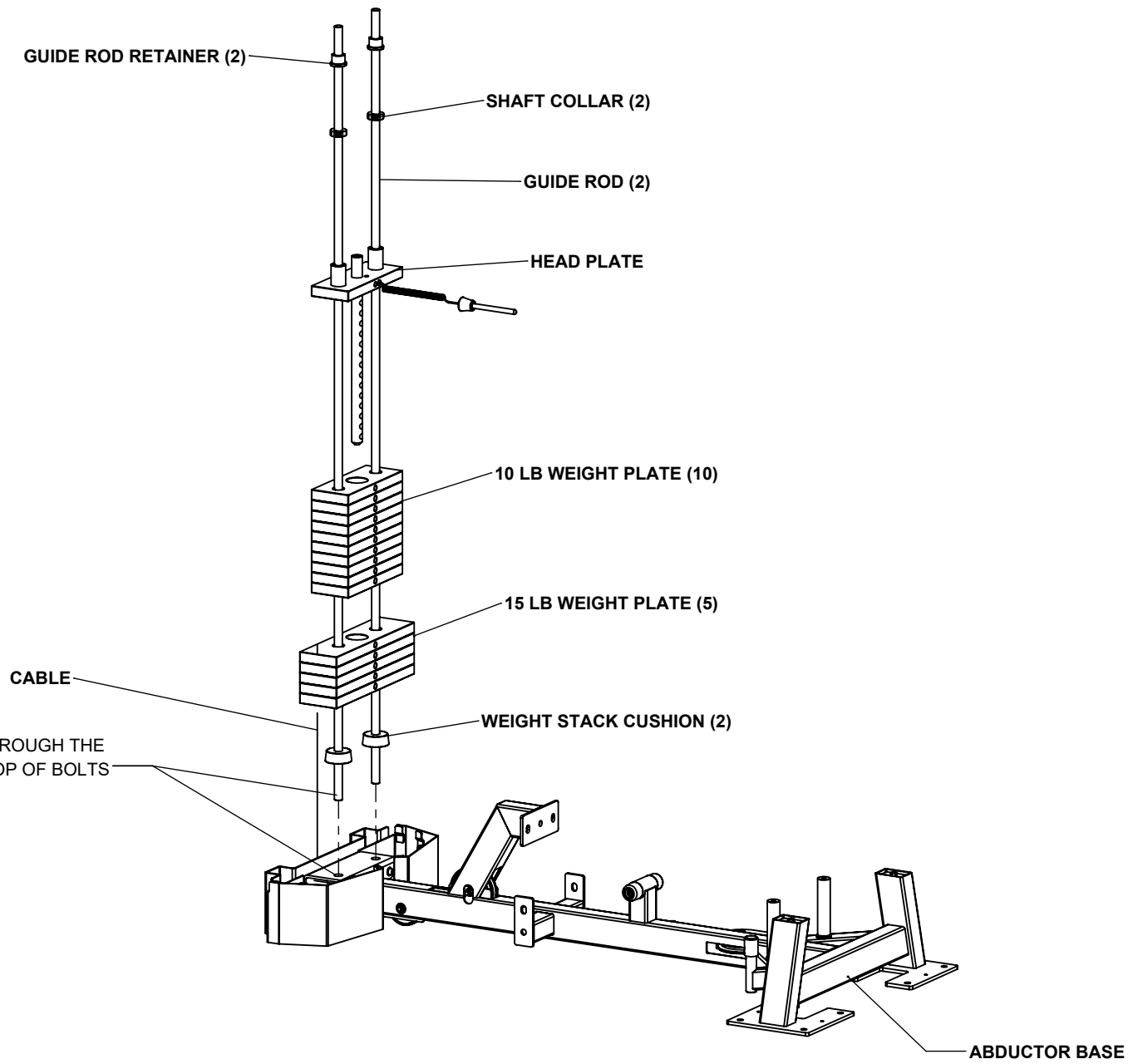

**STEP 7**

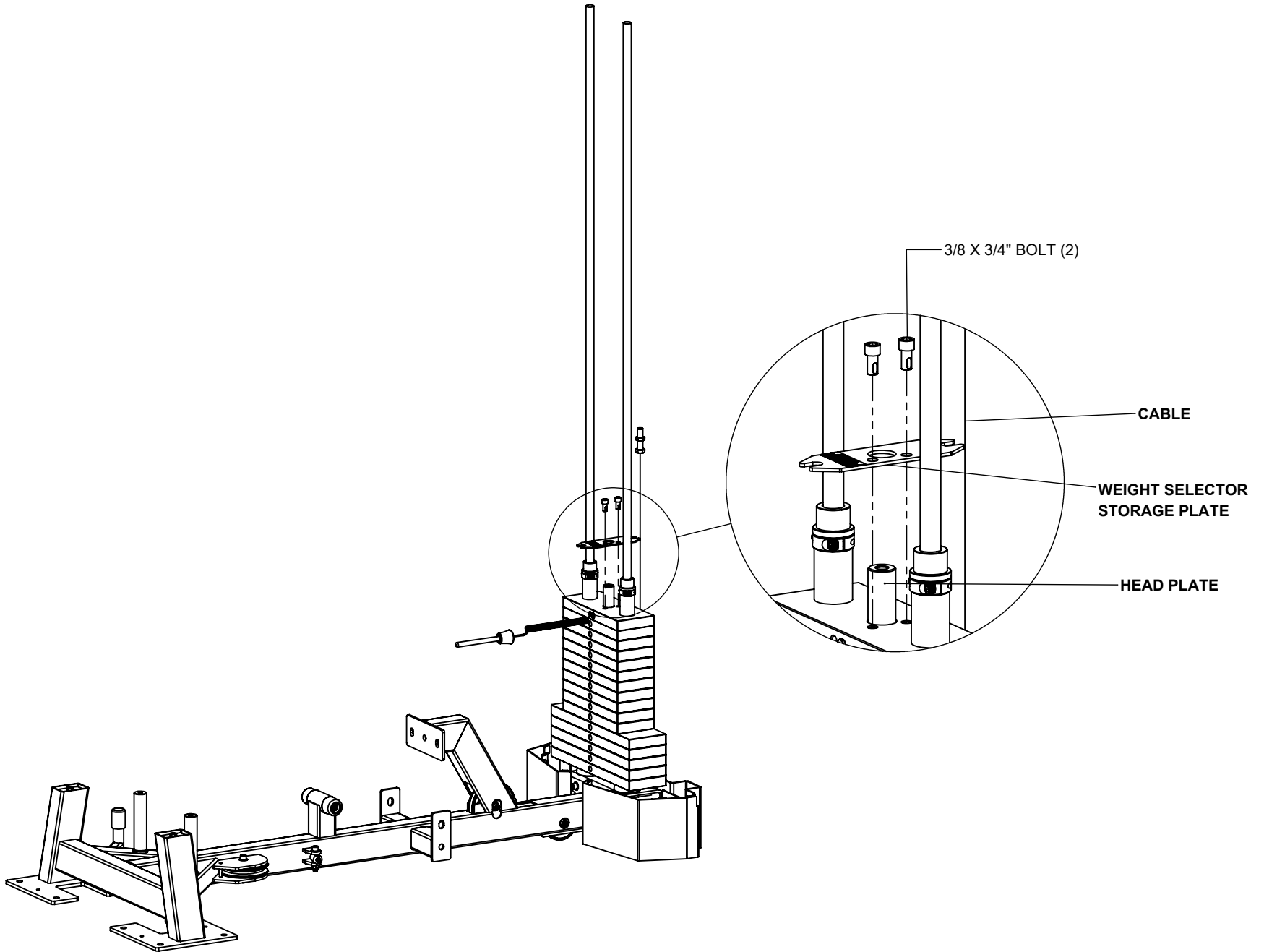

**NOTES:**

**SECURELY** tighten bolt connections in this step.

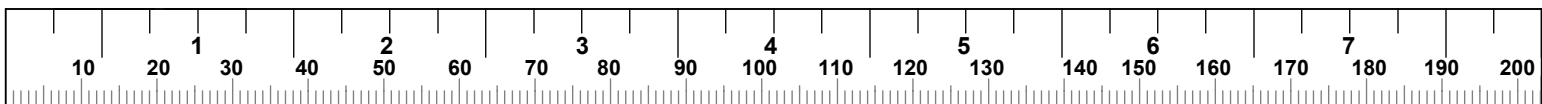

# STEP 8

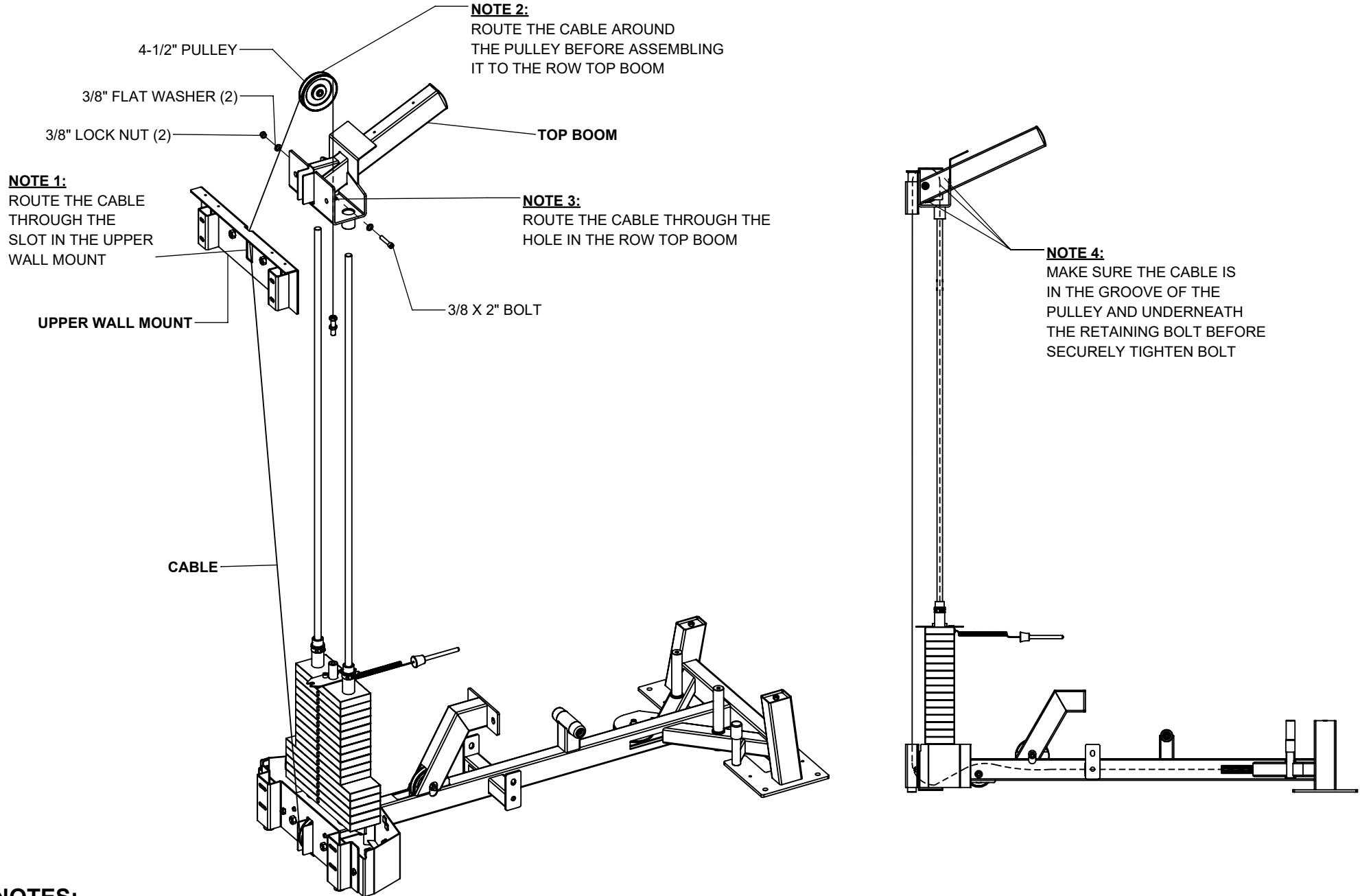

## NOTES:

**SECURELY** tighten bolt connections in this step.

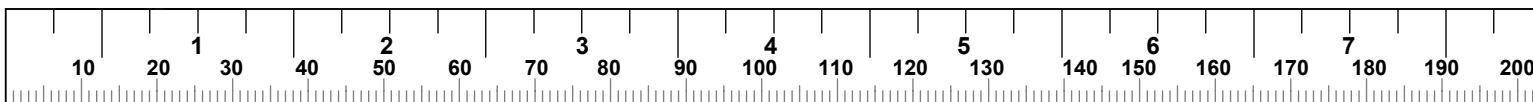

# STEP 9

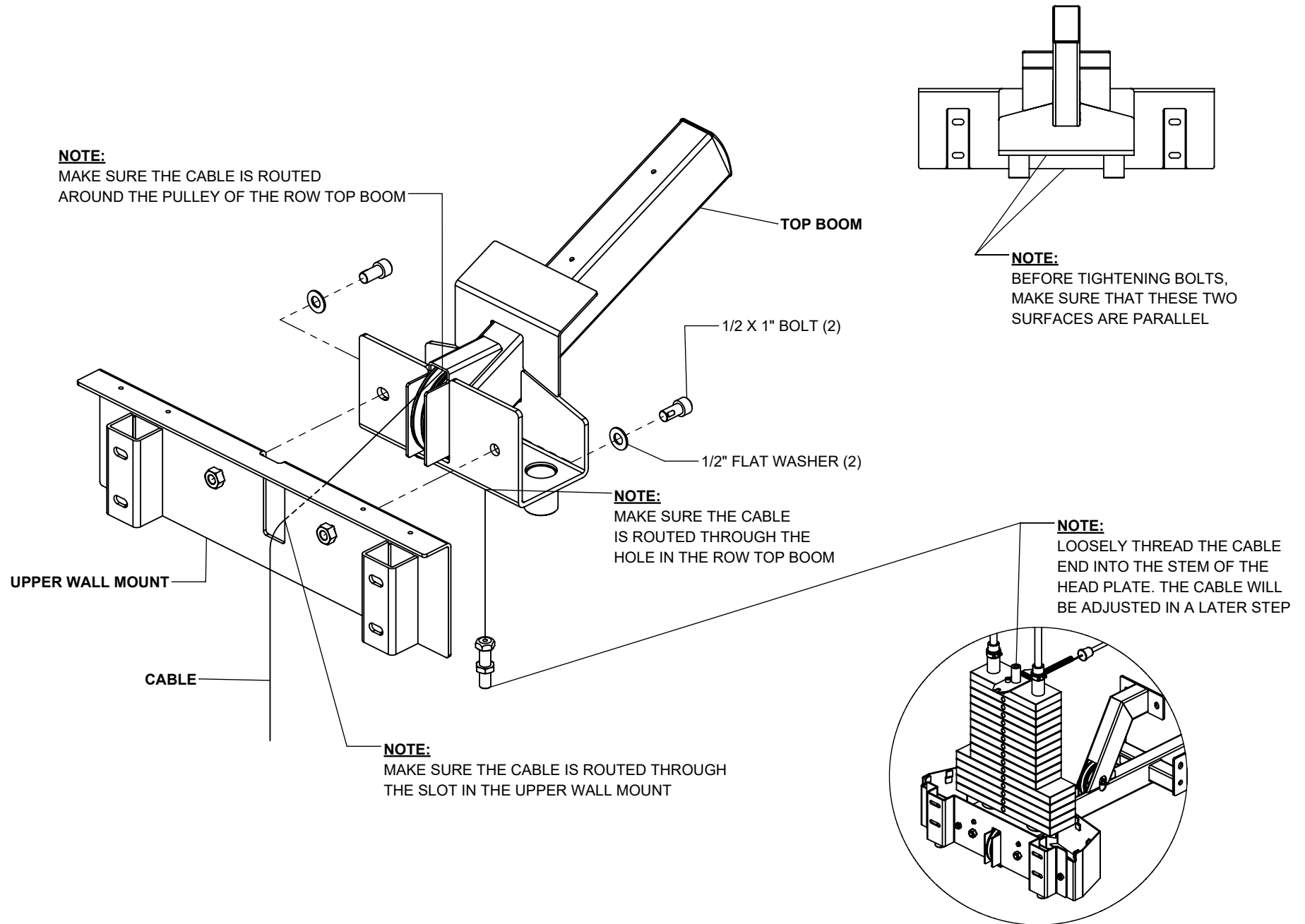

## NOTES:

**SECURELY** tighten bolt connections in this step.

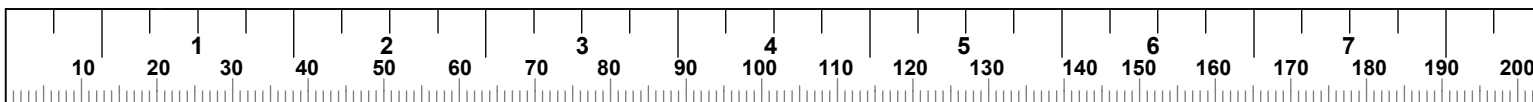

## STEP 10

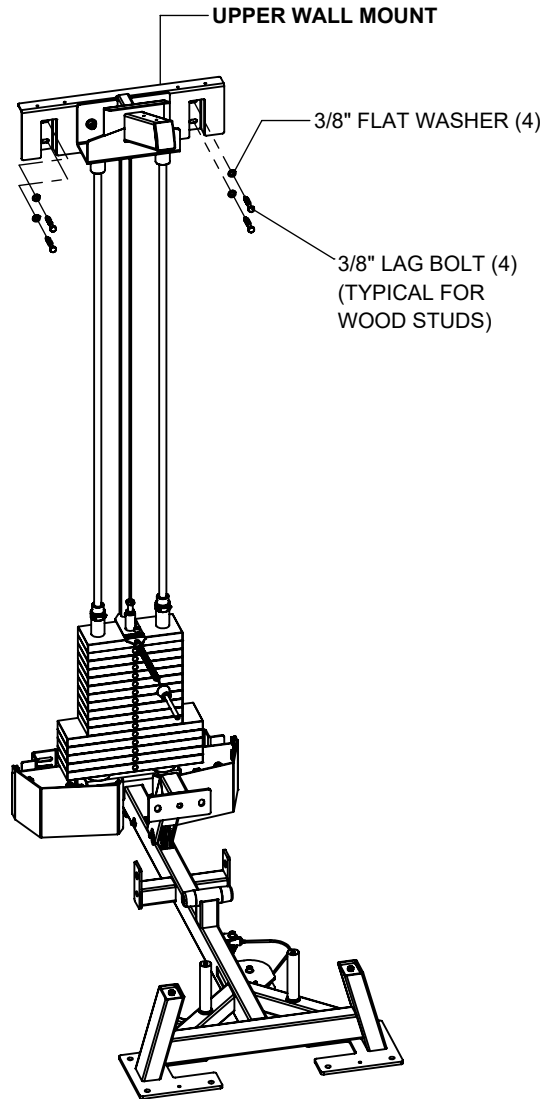

**NOTE:**  
MAKE SURE THE UPPER  
WALL MOUNT IS LEVEL

**WARNING:**  
THE UPPER WALL MOUNT **MUST** BE  
ANCHORED TO THE WALL USING FOUR  
WALL ANCHORS SUITABLE FOR THAT  
PARTICULAR WALL CONSTRUCTION

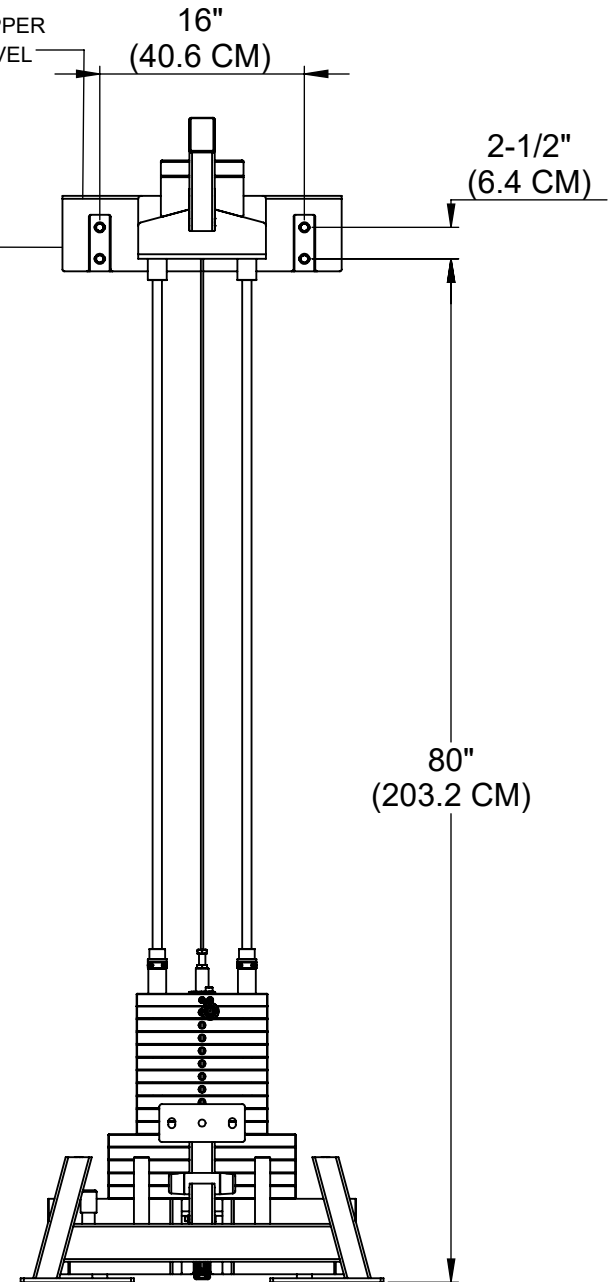

## NOTES:

The images shown above is the anchoring hardware used for attaching to typical walls with wood studs spaced 16" on center. The anchors used will depend on the wall construction. In all cases, all four anchoring locations must be used. The pull-out strength of the anchoring bolts used must be greater than or equal to 200lbs. (91kg)

**SECURELY** tighten bolt connections in this step.

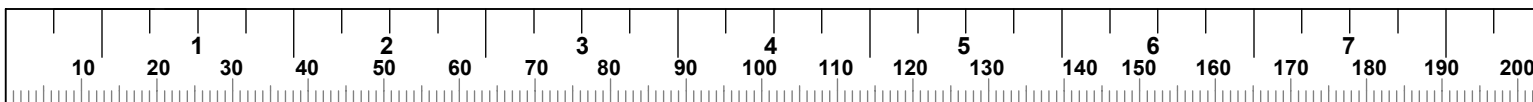

## STEP 11

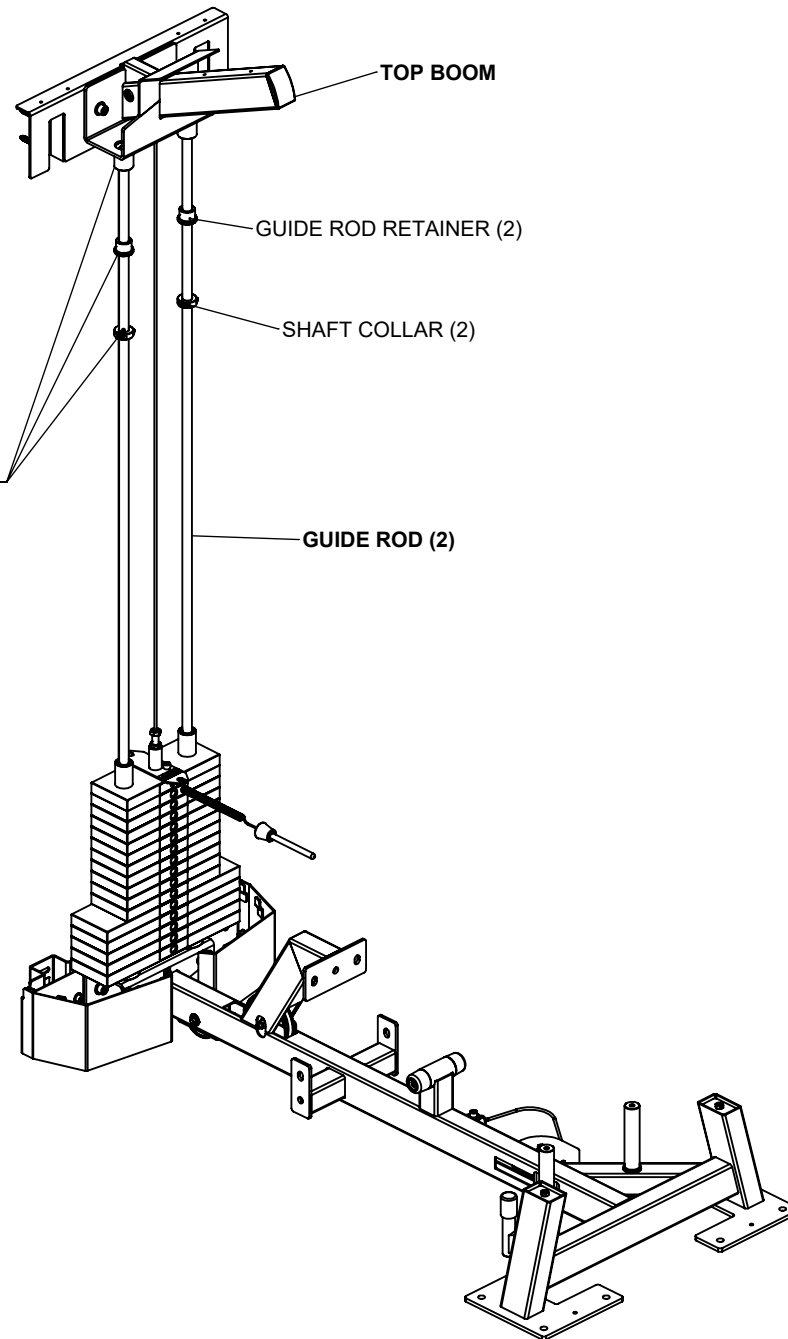

### **NOTE:**

SLIDE GUIDE ROD RETAINERS UP INSIDE TOP BOOM. SLIDE SHAFT COLLARS UP AGAINST GUIDE ROD RETAINERS AND **SECURELY** TIGHTEN BOTH SCREWS OF SHAFT COLLARS

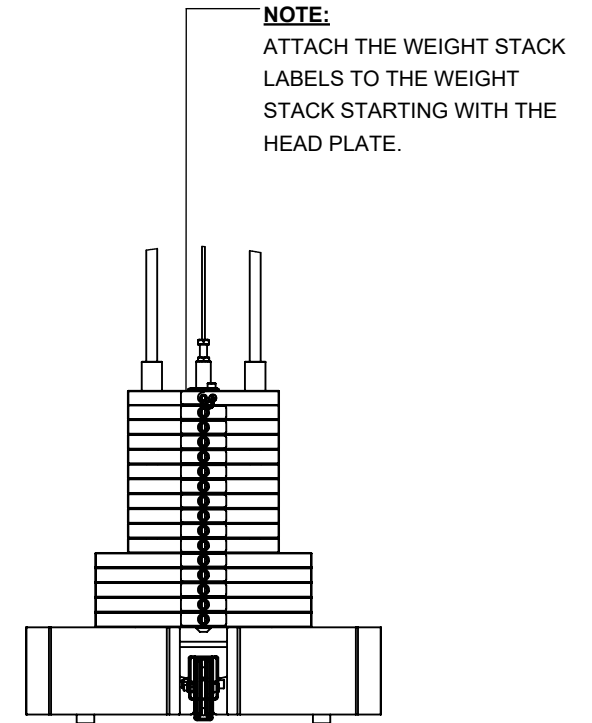

### **NOTE:**

ATTACH THE WEIGHT STACK LABELS TO THE WEIGHT STACK STARTING WITH THE HEAD PLATE.

### **NOTES:**

**SECURELY** tighten bolt connections in this step.

# STEP 12

**NOTE:**  
MAKE SURE THE SHROUD  
IS SEATED BETWEEN THE  
SHROUD SUPPORT AND  
THE FOUR TABS AS SHOWN.

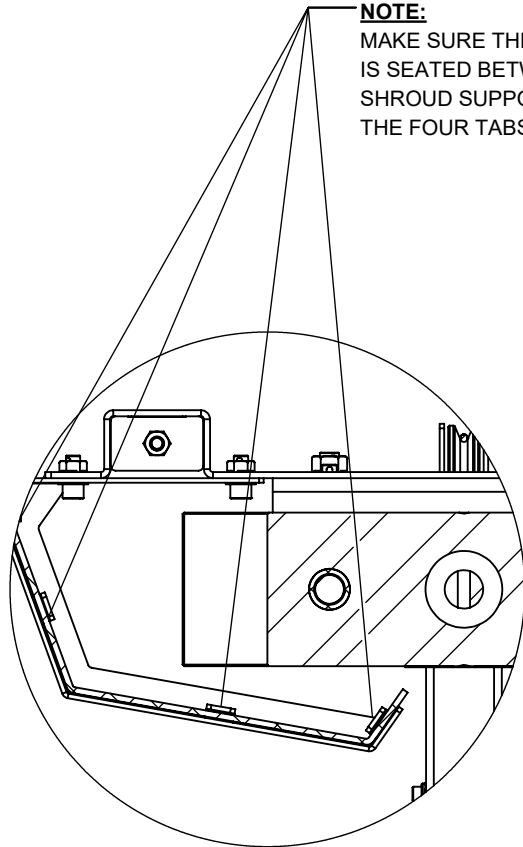

TOP VIEW LEFT

**NOTE:**  
MAKE SURE THE SHROUD  
IS SEATED BETWEEN THE  
SHROUD SUPPORT AND  
THE FOUR TABS AS SHOWN.

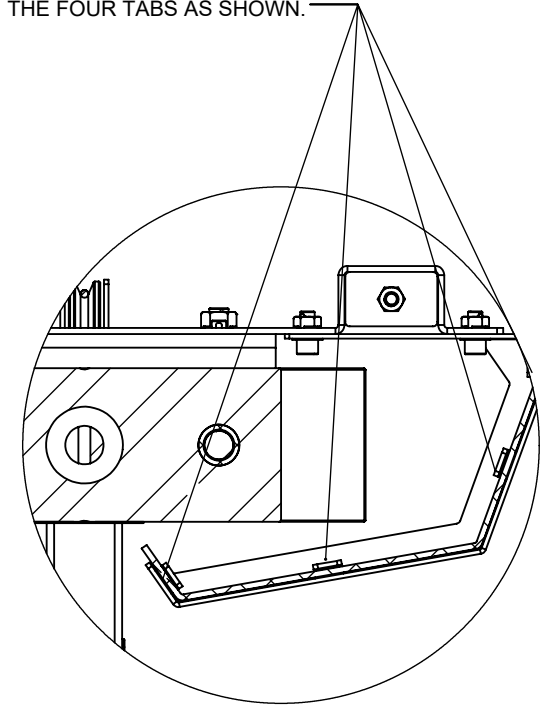

TOP VIEW RIGHT

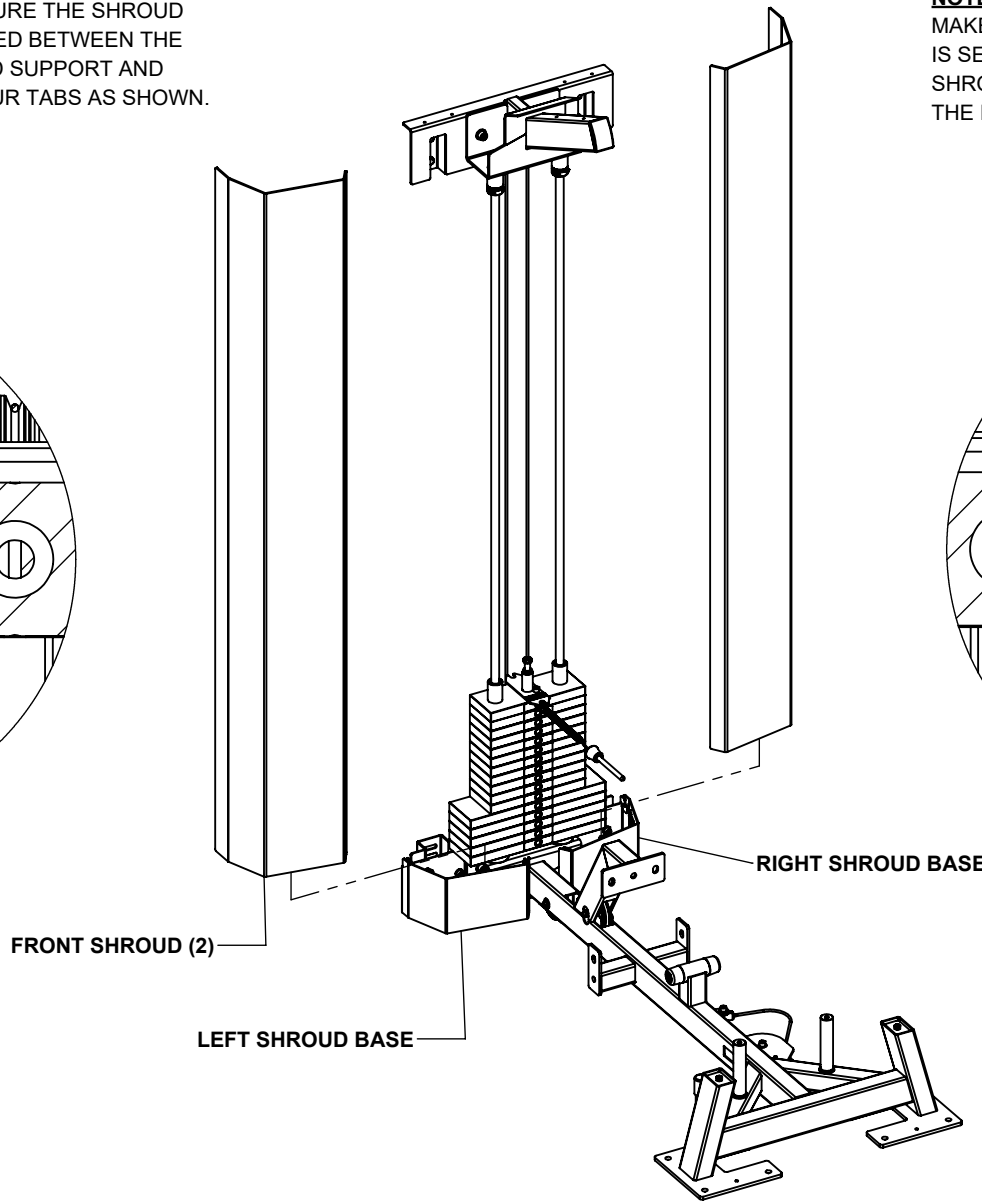

## STEP 13a

**NOTE:**

MAKE SURE INTERNAL GROOVES OF THE TOP CAP FIT DOWN OVER THE TOP EDGES OF BOTH FRONT SHROUDS.

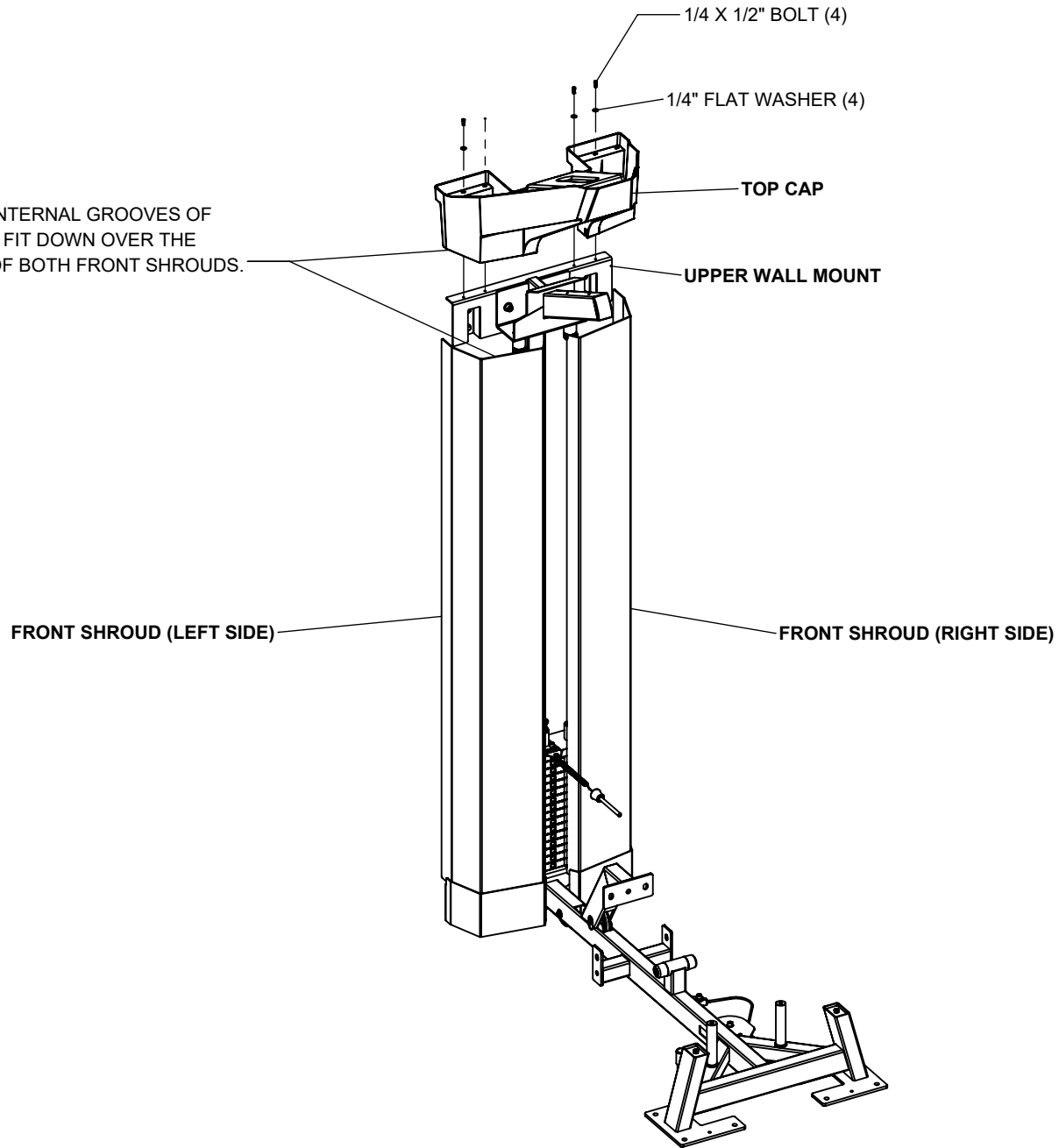

**NOTES:**

**LOOSELY** tighten bolt connections in this step.

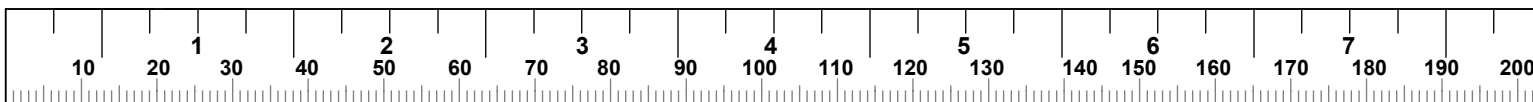

**STEP 13b**

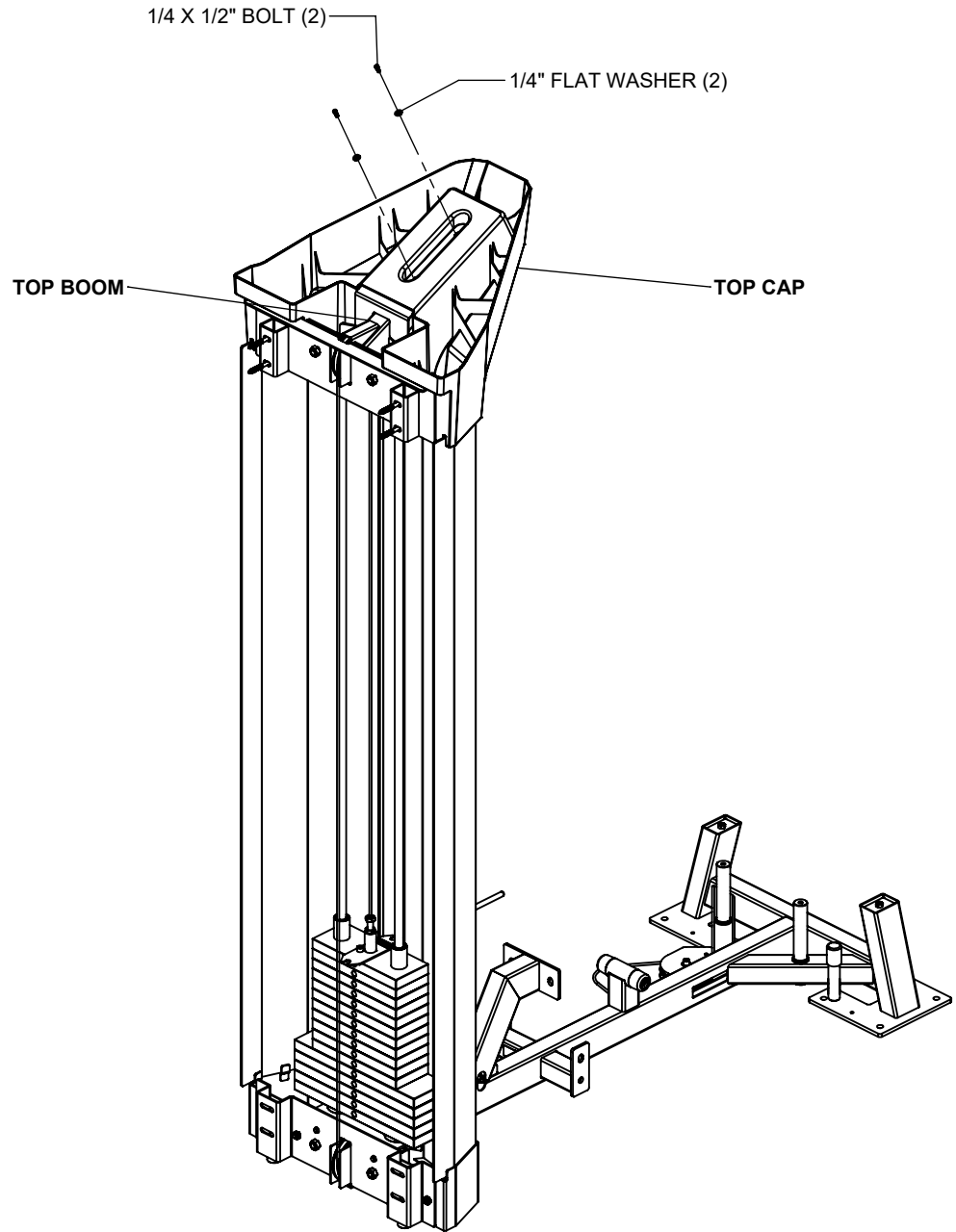

**NOTES:**

**SECURELY** tighten bolt connections in this step, and previous step.

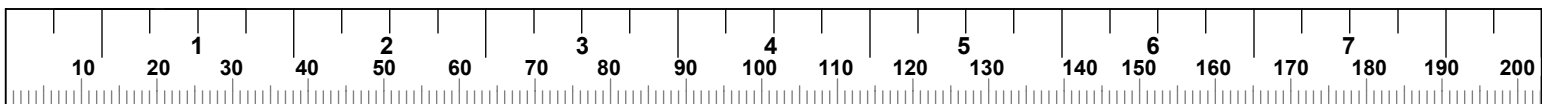

**STEP 14**

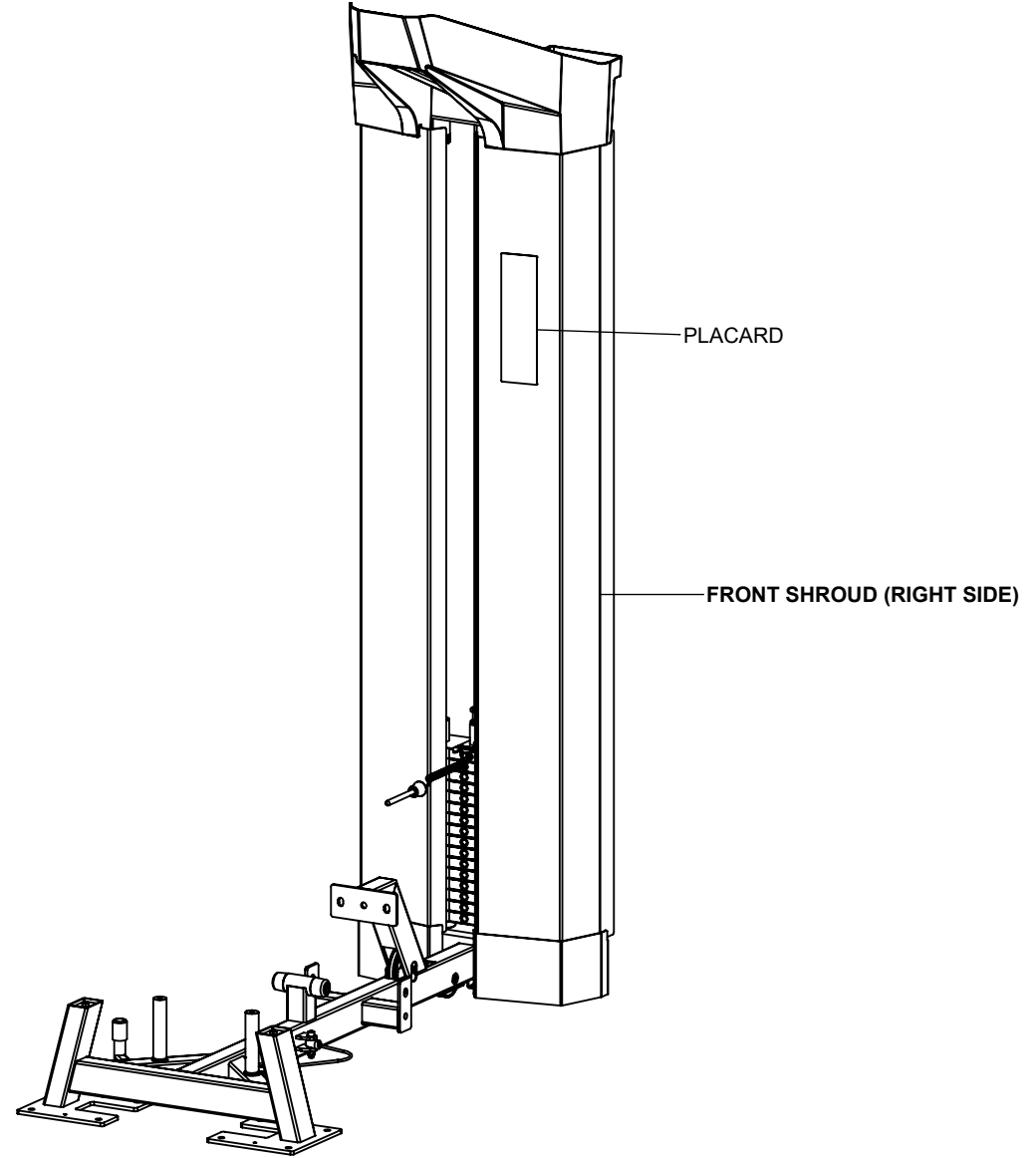
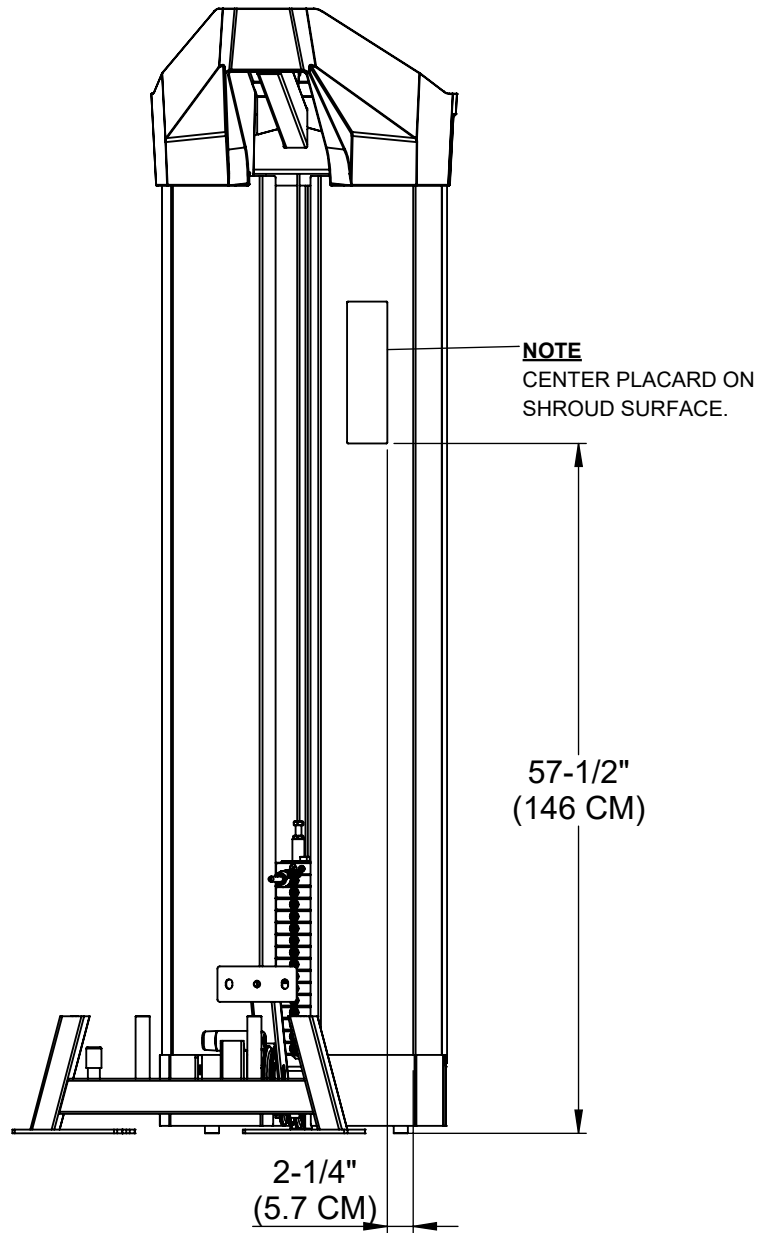

**STEP 15**

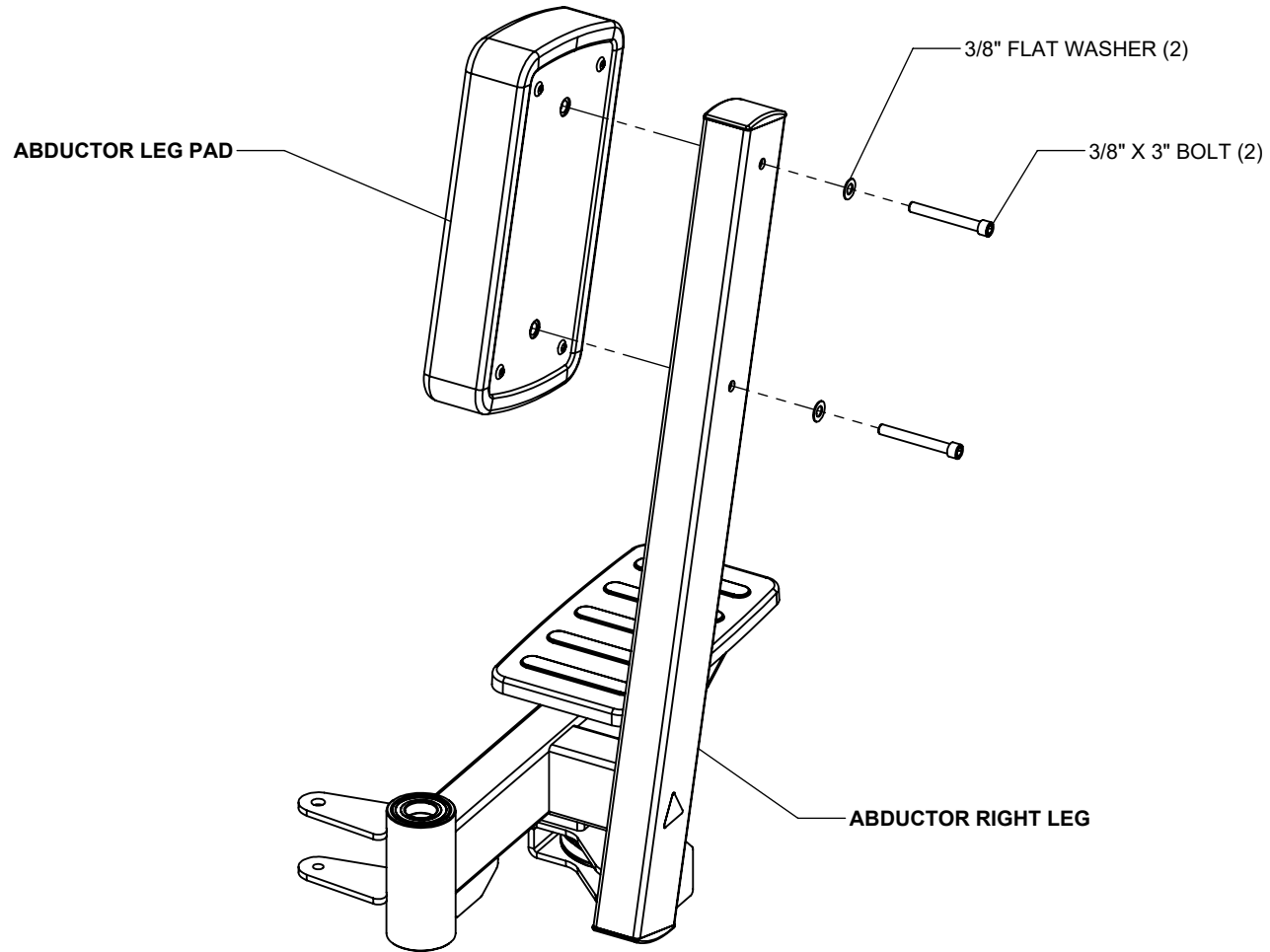

**NOTES:**

**SECURELY** tighten bolt connections in this step.

Some parts have been hidden for illustration clarity.

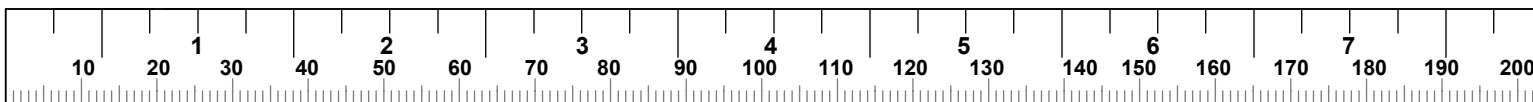

## STEP 16

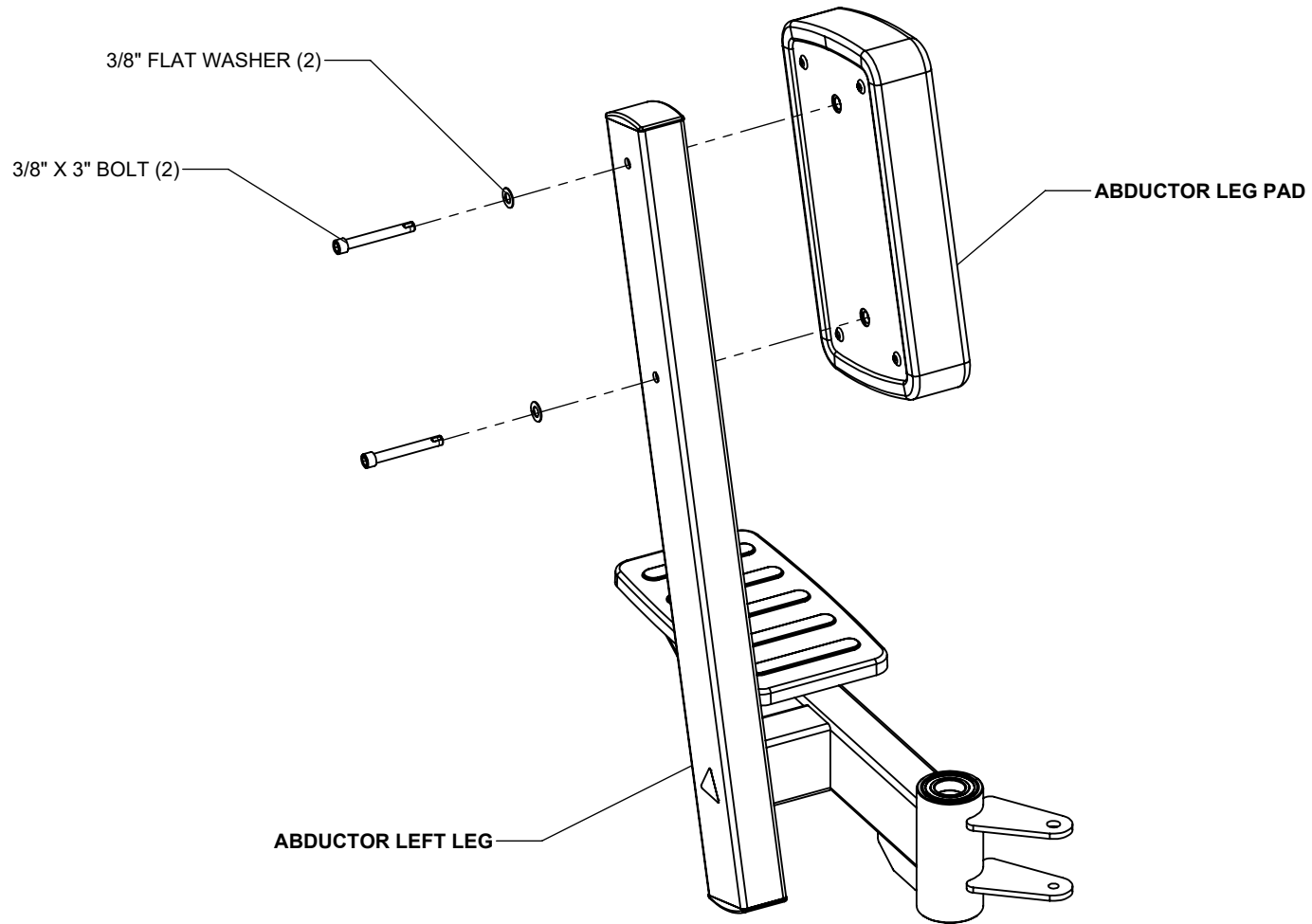

### NOTES:

**SECURELY** tighten bolt connections in this step.

Some parts have been hidden for illustration clarity.

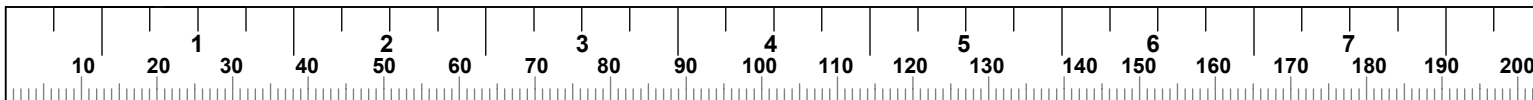

**STEP 17**

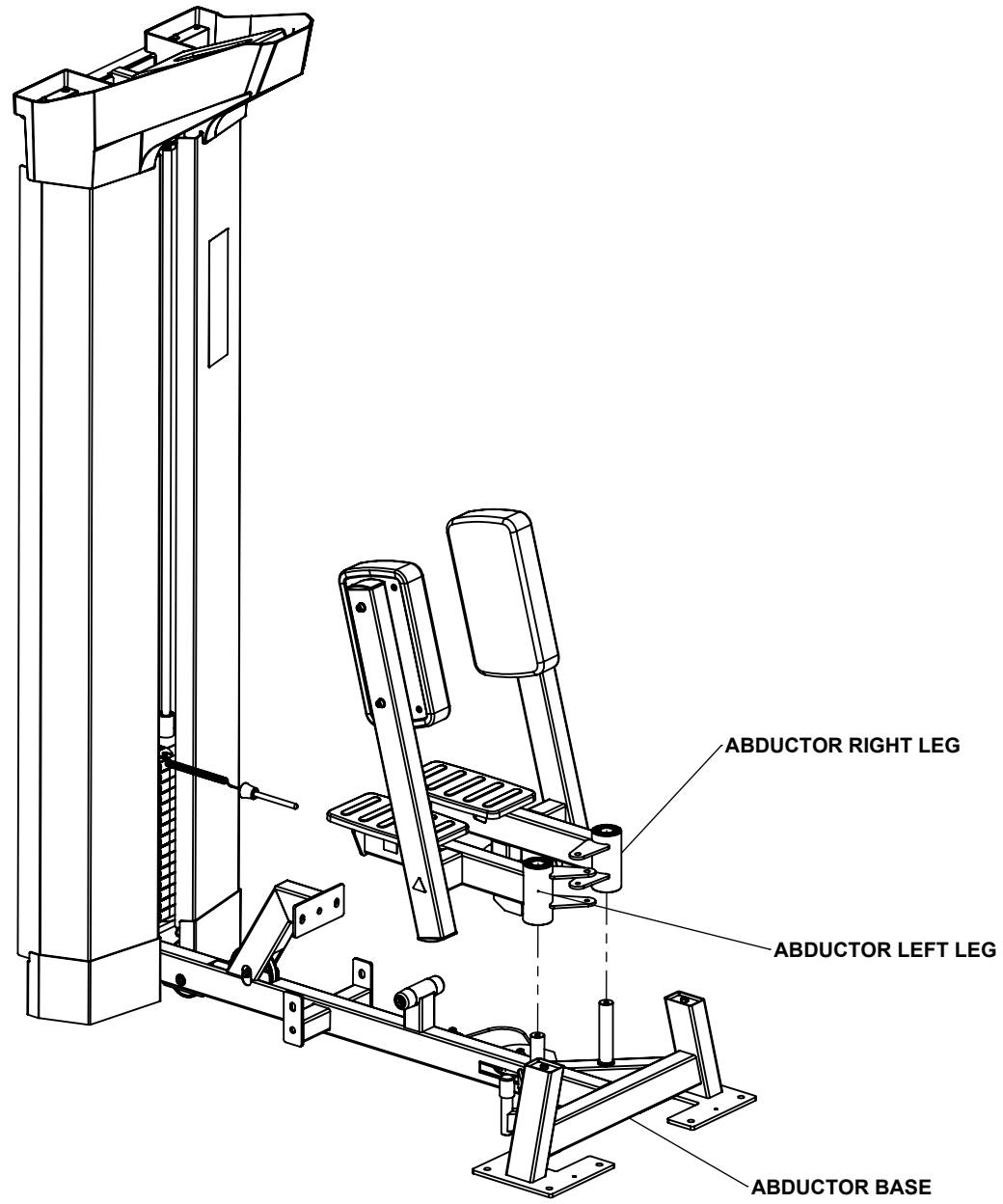

**STEP 18**

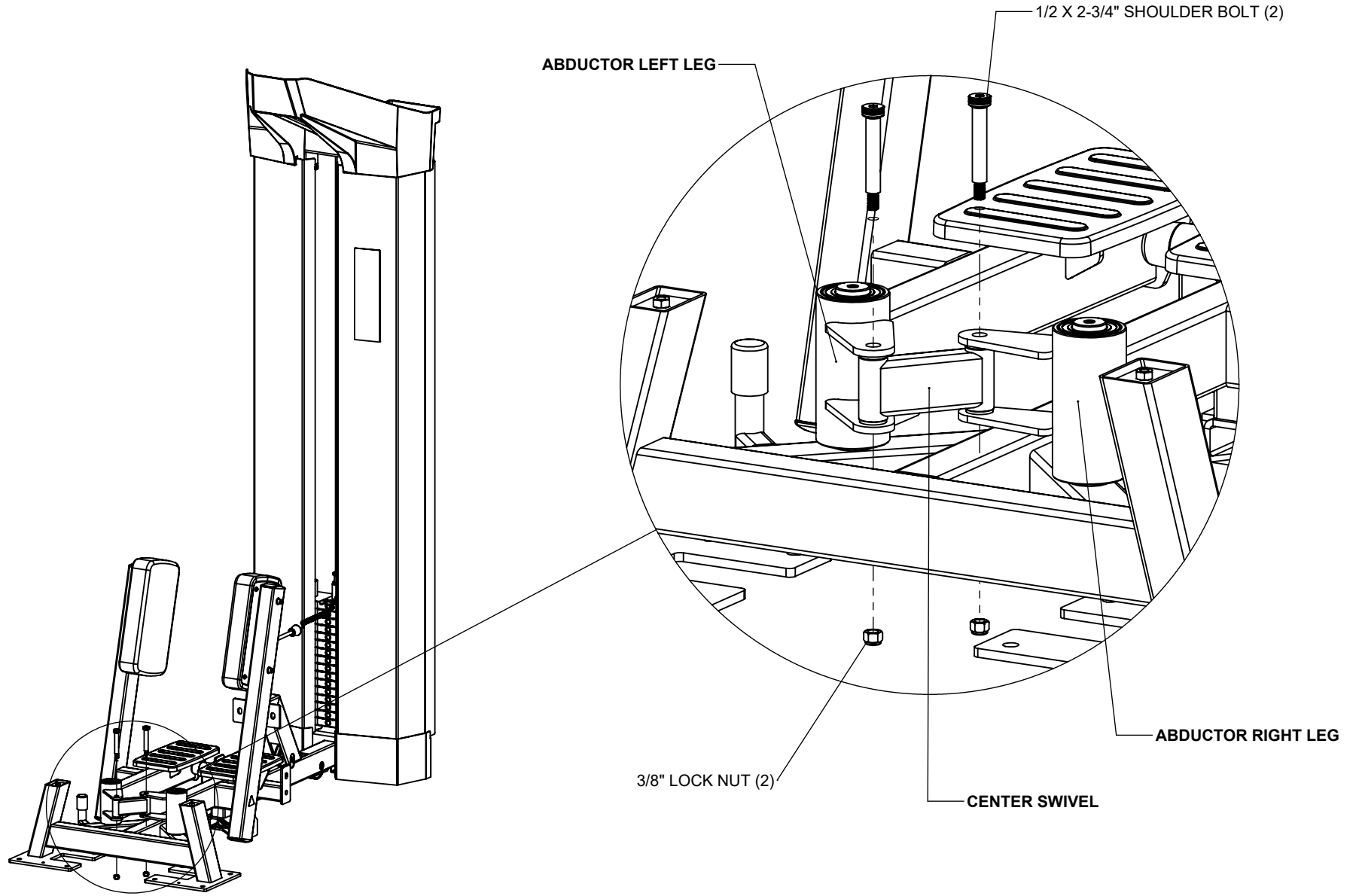

**NOTES:**

**SECURELY** tighten bolt connections in this step.

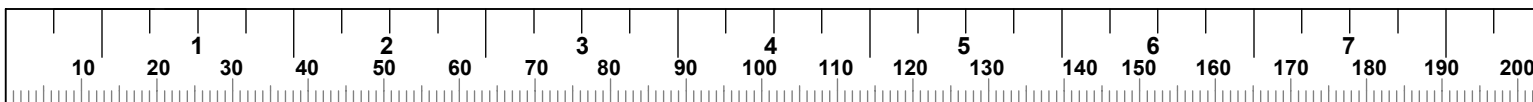

## STEP 19

### NOTE:

THREAD THE CABLE THROUGH THE PULLEY OF THE ABDUCTOR RIGHT LEG. REMOVE THE CORE FROM THE BASE AND REMOVE THE SPACER. PLACE THE CABLE END INSIDE THE CORE. PLACE THE SPACER BACK INTO THE CORE AND REPLACE THE BOLT CONNECTING IT TO THE BASE. ONCE THE CABLE END IS IN PLACE **SECURELY** TIGHTEN JAM NUT.

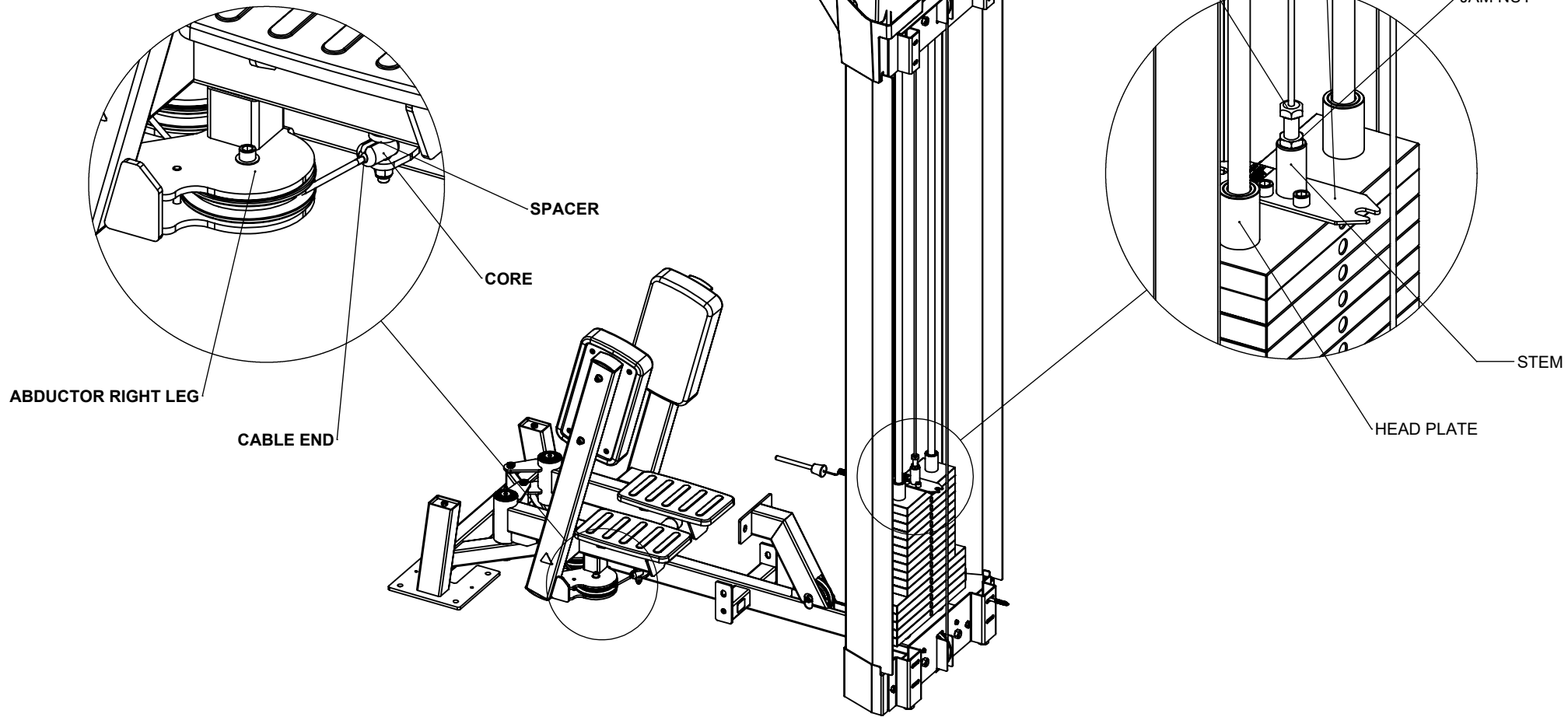

### NOTES:

**SECURELY** tighten connections in this step.

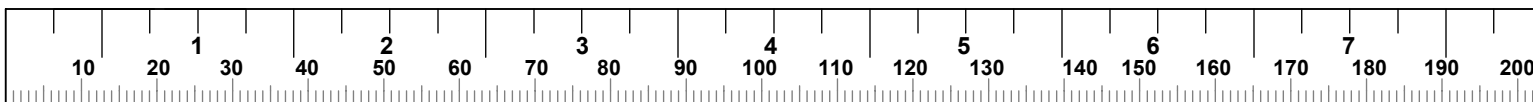

**STEP 20**

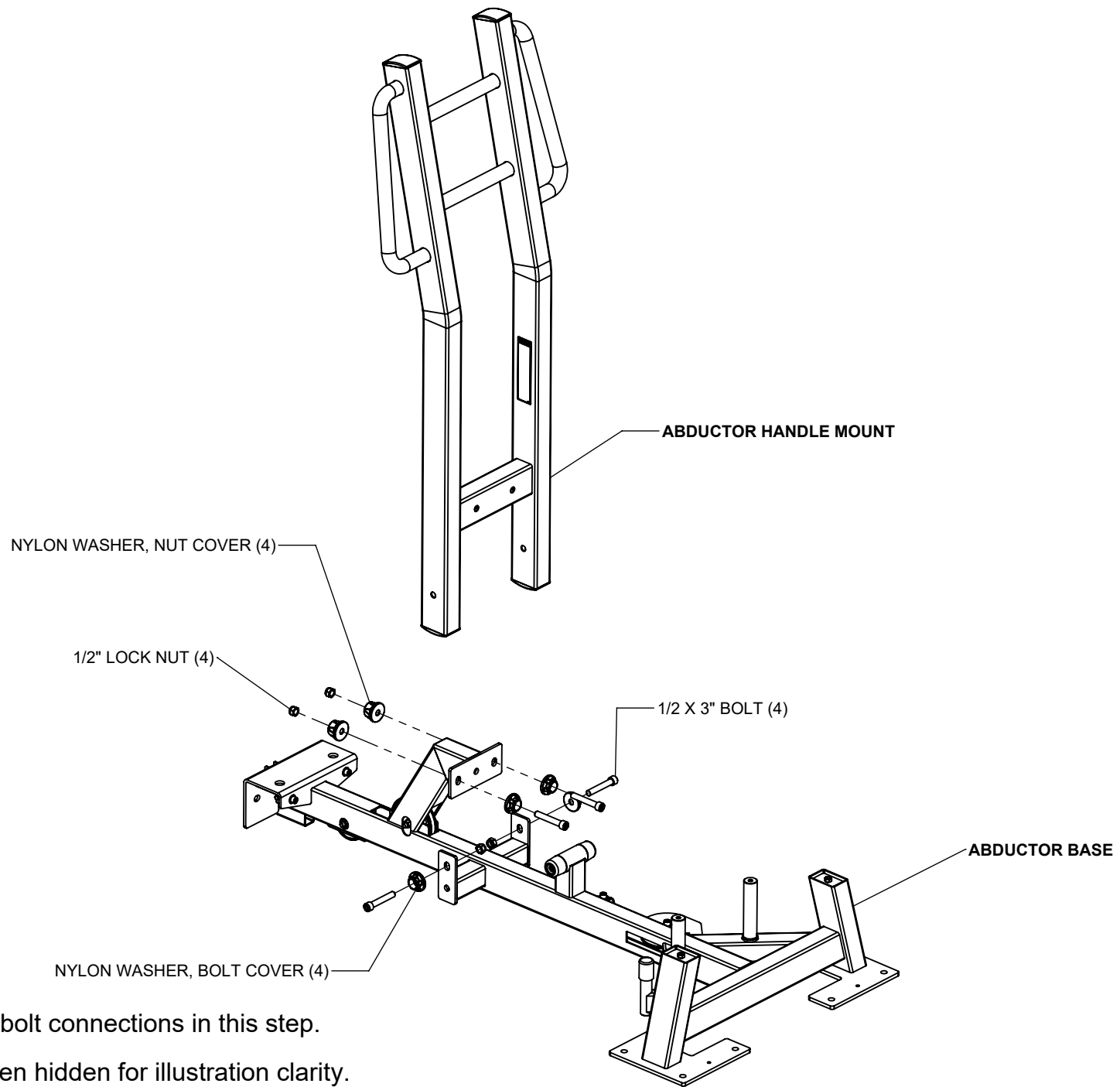

**NOTES:**

**SECURELY** tighten bolt connections in this step.

Some parts have been hidden for illustration clarity.

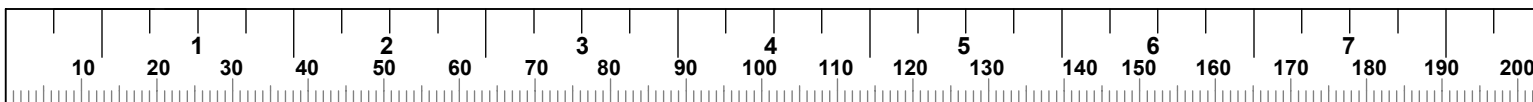

**STEP 21**

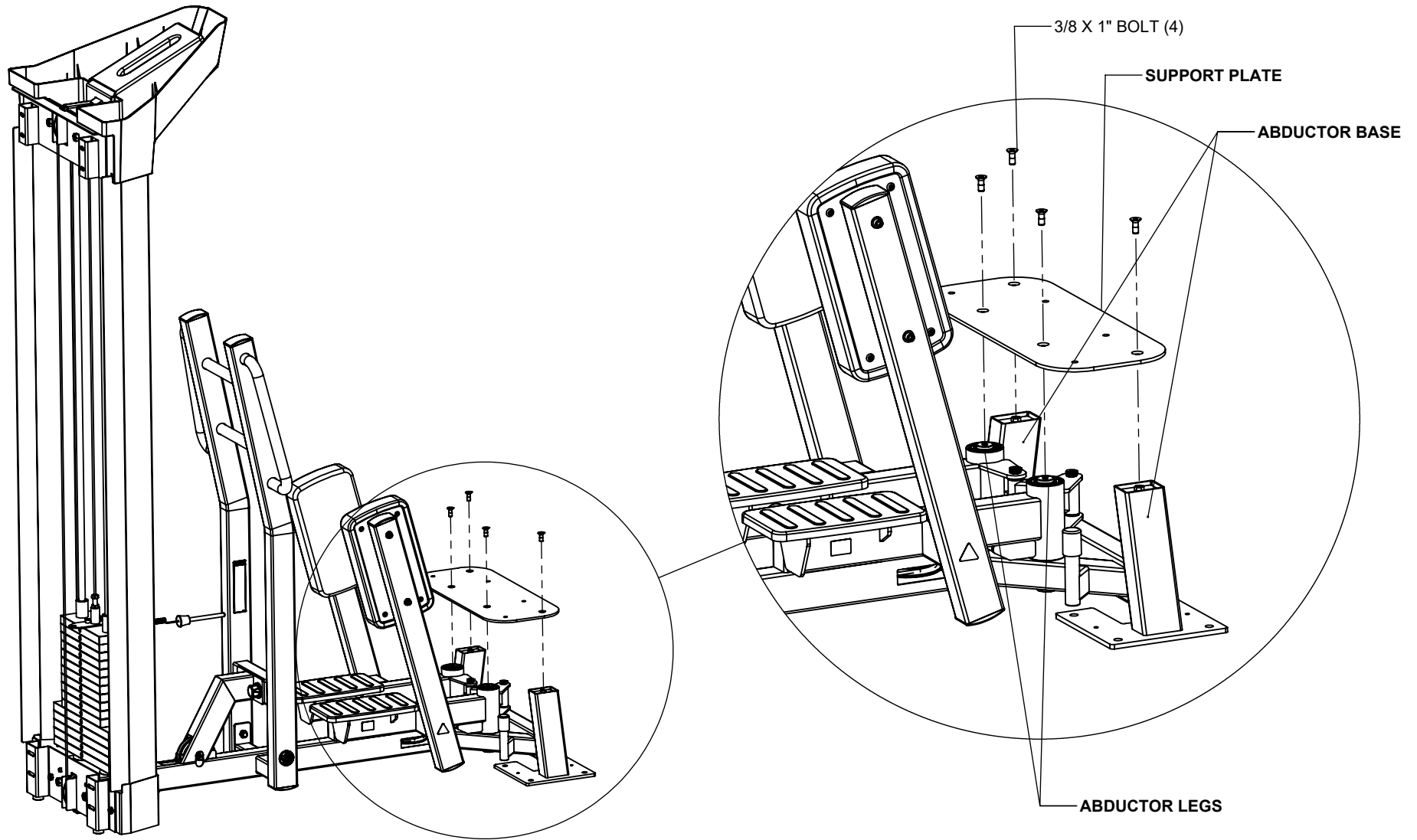

**NOTES:**

**SECURELY** tighten bolt connections in this step.

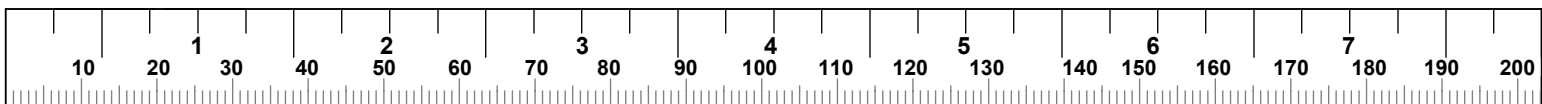

## STEP 22

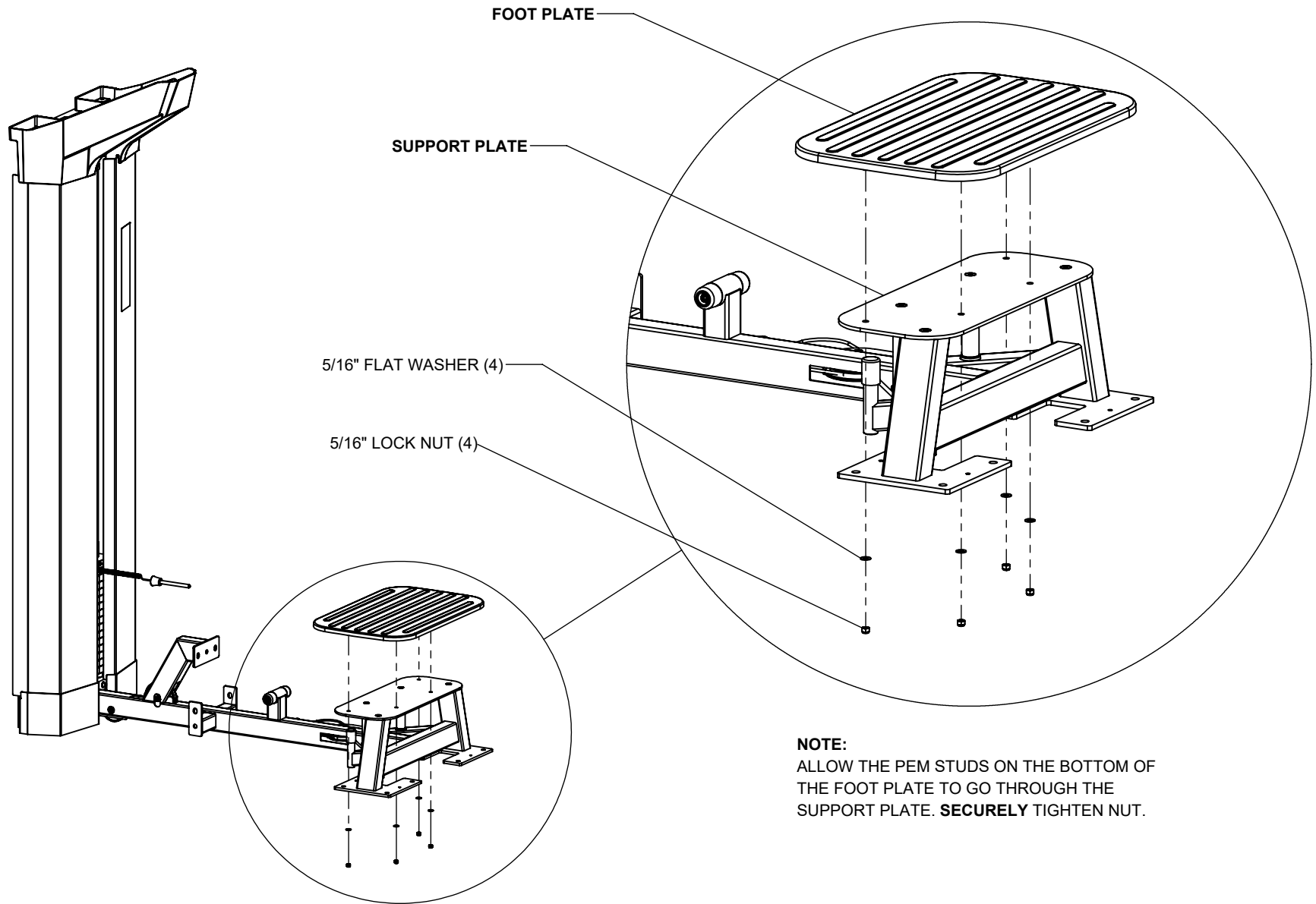

### NOTES:

**SECURELY** tighten bolt connections in this step.

Some parts have been hidden for illustration clarity.

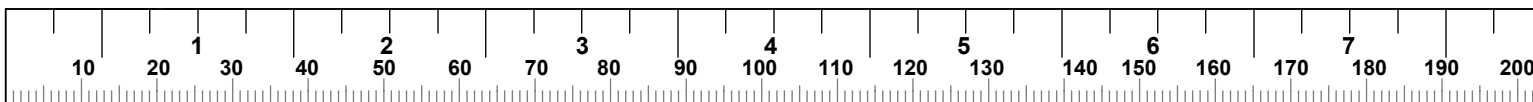

## STEP 23

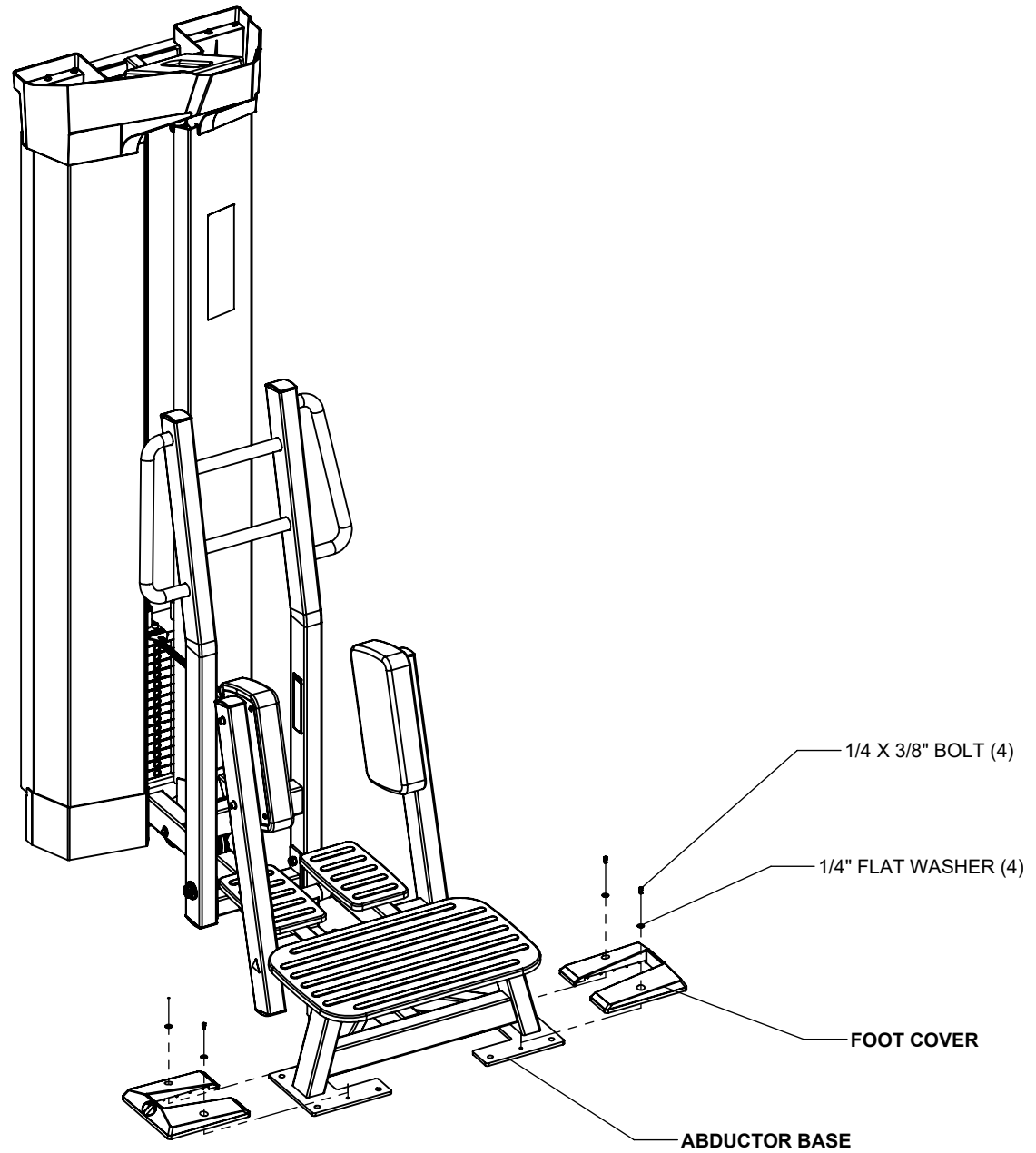

### NOTES:

**SECURELY** tighten bolt connections in this step.

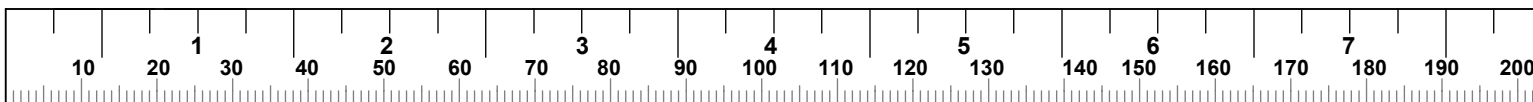

## MAINTENANCE

**GUIDE RODS:** Clean and lubricate with a silicone or teflon based lubricant

**INSPECTION:** Once a month, check for loose bolts. Tighten if necessary.

**CABLES:** Check tension, end fitting and cable coating. Replace if damage or worn. (NOTE: NEW CABLES ALWAYS STRETCH DURING USE. REFER TO STEP 19, PAGE 22 TO ADJUST CABLE TENSION)

**FRAME:** Clean with a damp cloth.

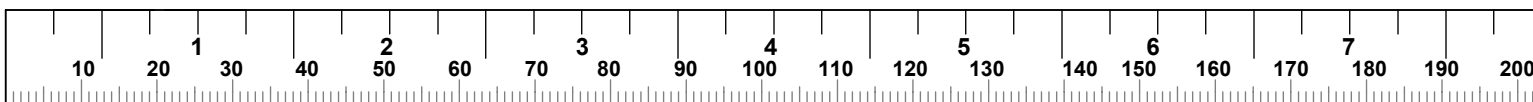
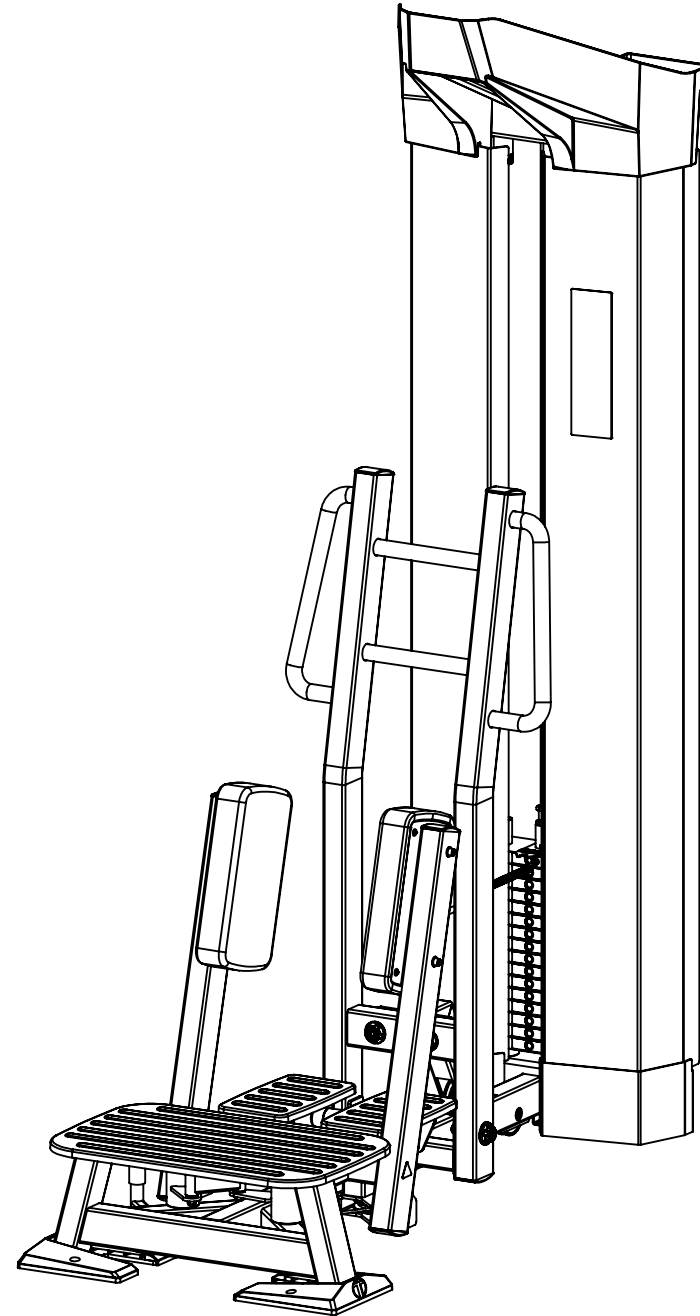

**LIVE AREA**

**TOP VIEW**

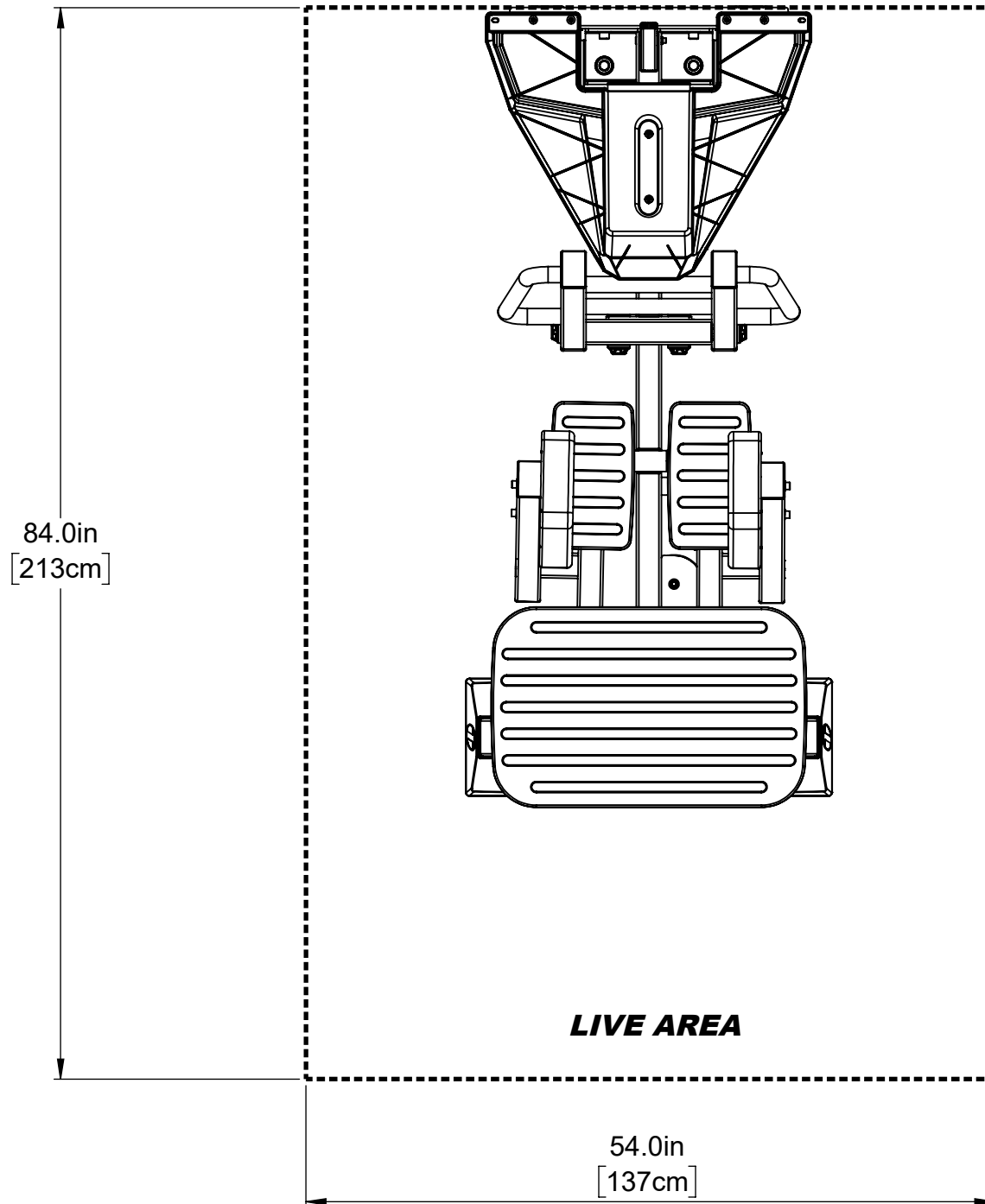

***DIMENSIONS***

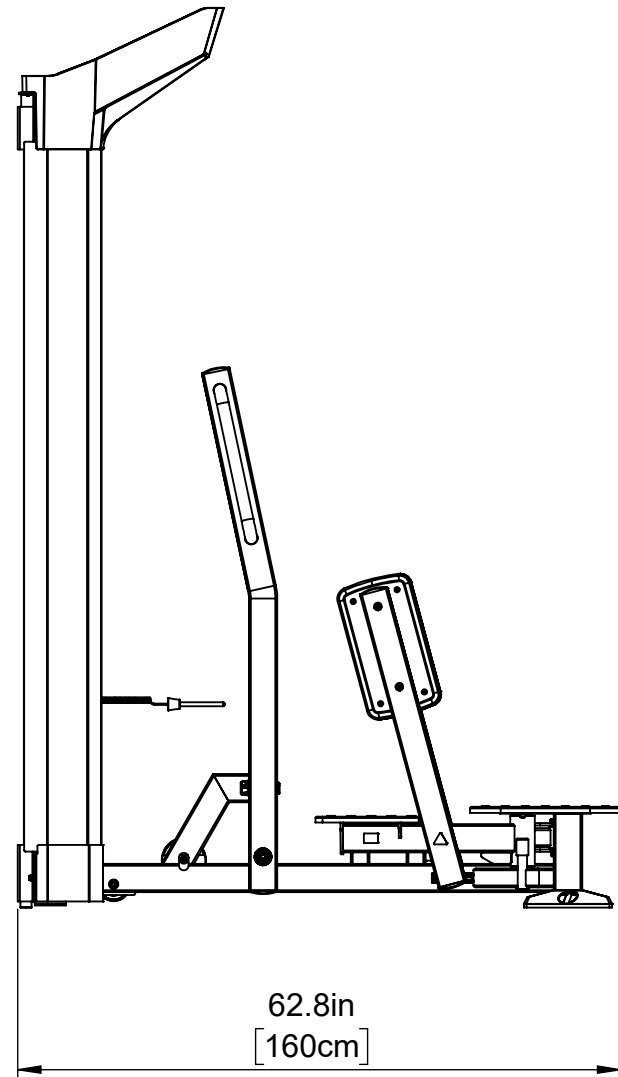
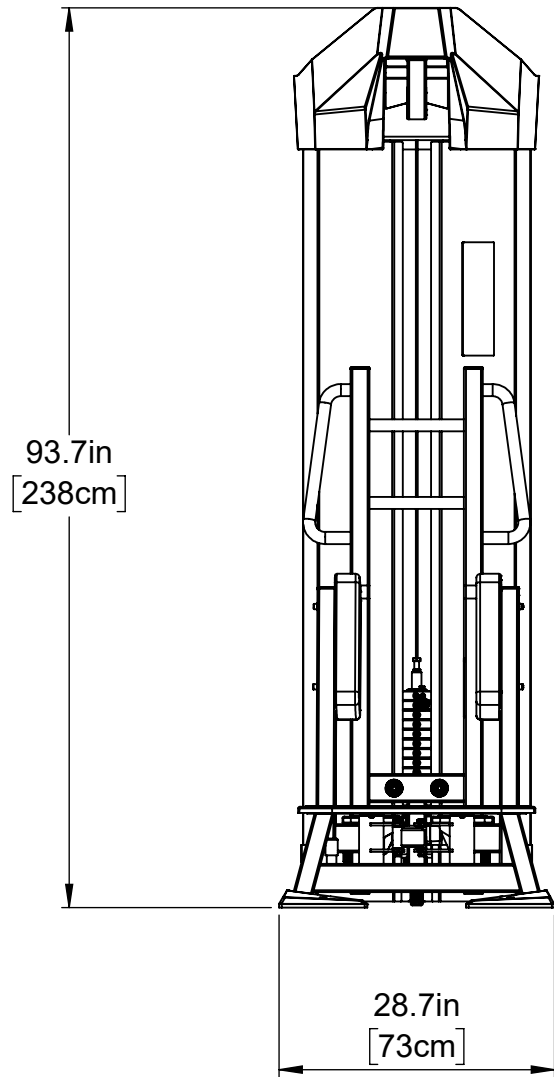

**TOTAL UNIT WEIGHT : 576 LBS [261 KG]**